

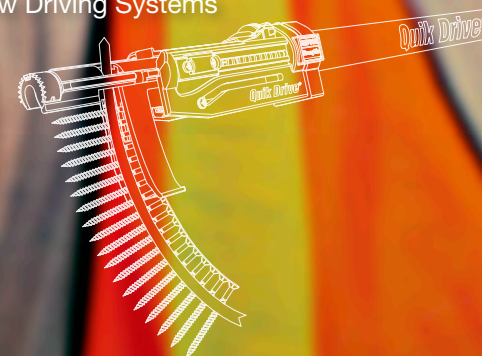

FASTENING SYSTEMS

C-F-14

Includes Quik Drive® Auto-Feed Screw Driving Systems



(800) 999-5099
www.strongtie.com

Strong-Drive[®]

STRUCTURAL FASTENERS

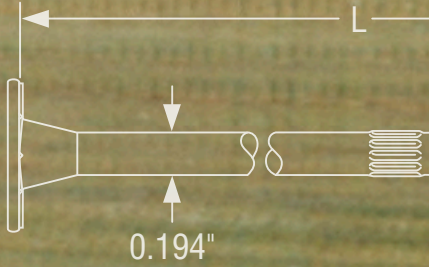

Deck-Drive[™]

PREMIUM FASTENERS

Quik Drive[®]

AUTO-FEED SCREW DRIVING SYSTEMS

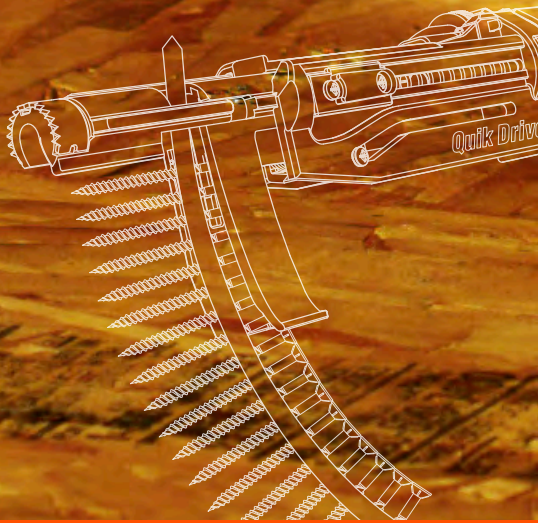

Driven To Exceed Expectations

In the fastener marketplace, Simpson Strong-Tie stands apart from the rest. Quality and reliability is our top priority. That's why we hire PhDs, metallurgists, materials engineers, and structural engineers to create the best possible fasteners. And why each production run goes through rigorous testing to ensure our products can handle higher loads, resist corrosion, and make installation more efficient.

Now you know why builders trust Simpson Strong-Tie quality and reliability. For more information about custom fasteners or how we can contribute to the success of your next project, please call (800) 999-5099 to speak with one of our knowledgeable, trained fastening professionals.

To learn more, visit: www.strongtie.com/fasteners

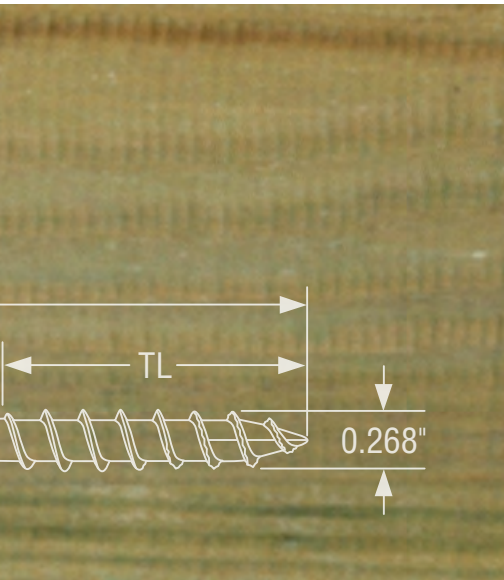

Table of Contents

General Information

Important Information Warnings and Warranties	10
General Notes	11-12
Corrosion Information	13-15
Coatings and Materials	16-17
Fastener Overview	18
Nail Types	19
Color Guide for Composite/PVC Decking	20-21
Screw Features	22
How Self-Drilling Screws Work	23-24
Custom-Order Nails	25

Strong-Drive® Structural Fasteners	26-27
---	--------------

Deck-Drive™ Premium Decking Screws	28-29
---	--------------

Quik Drive® Auto-Feed Screw Driving Systems	30-31
--	--------------

Fastener Application Guide

Decks, Docks and Boardwalks	34-35
Subfloor and Sheathing Applications	36
Underlayment and Backerboard Applications	37
Siding on Wood and Steel	38-39
Roofing	40-41
Wood Framing	42-43
Fasteners for Simpson Strong-Tie® Connectors	44
Finishing, Millwork and Trim	45
Fastening to Metal	46-47
Fencing	48-49
Cooling Towers	50-51
Log Homes	52
Steel Decking	52
Truss-Ply Fastening Applications	53
Drywall and Exterior Gypsum Sheathing Applications	53
Crating	54
Boat Building/Marine Trade	55-56

Screws and Nails

Exterior Wood Screws

Strong-Drive® SDWS Timber Screw	58
Strong-Drive® SDWH Timber-Hex Screw	59
Strong-Drive® SDWH Timber-Hex SS Screw	60
Strong-Drive® SDS Heavy-Duty Connector Screw	61
Strong-Drive® SD Connector Screw	62
Deck-Drive™ DSV Wood Screw	63
Deck-Drive™ DWP Wood SS Screw	64
DWP Flat-Head	64
DWP Trim-Head	65
Deck-Drive™ DHPD Hardwood Screw	66
Bugle-Head Wood Decking Screw – 6-Lobe Drive	67
Bugle-Head Wood Decking Screw – Square Drive	68-69
Trim-Head Wood Decking Screw – Square Drive	70-71
Trim-Head Wood Decking Screw – 6-Lobe Drive	72-73

Composite Decking Screws

Dexter™ Composite-Decking Screw	74-75
Composi-Lok™ Composite-Decking Screw	76

Interior Wood Screws

Strong-Drive® SDWC Truss Screw	77
Strong-Drive® SDW EWP-Ply Screw	78
Strong-Drive® SDW Truss-Ply Screw	79
Strong-Drive® SDWS Log Screw	79
Strong-Drive® SDWF Floor-to-Floor Screw	80
Wafer-Head Screw	80

Exterior Nails

Premium Siding Nail	81
Premium Common Nail	81
Box Nail – Annular Ring Shank	82
Cedar and Redwood Decking Nail	83
Wood Siding Nail	84
Cedar Trim Nail	84
Common Nail – Annular Ring Shank	85
Common Nail – Smooth Shank	86
Fencing Nail	87
Fiber-Cement Siding Nail	87
Finishing Nail	88
Nail with EPDM Washer – Annular Ring Shank	89
Nail with EPDM Washer – Spiral Shank	89
Post and Beam Nail – Annular Ring Shank	90
Preservative-Treated Wood Decking Nail	91
Pyramid-Head Nail	92
Painted Siding Nail	93-94
Shake and Shingle Siding/Roofing Nail	95
Washed Roofing Nail	96
Roofing Nail – Annular Ring Shank	97-98
Roofing Nail – Smooth Shank	99
Tile/Slating Nail – Annular Ring Shank	100
Tile/Slating Nail – Smooth Shank	101

Specialty

Strong-Drive® SCNR Ring-Shank Connector Nail	102
Strong-Drive® SCN Smooth-Shank Connector Nail	103
PVC Trim-Board Nail	103
Crate Screw	103
Escutcheon Pins	104
Fencing Staples	105
Hog Rings – Blair Shaped	105
Hog Rings – Hill Pattern	105
Marine Screw – Pan Head	106
Marine Screw – Flat Head	107
Marine Screw – Oval Head	108
Fiber-Cement Screw	109
Metal-Panel Screw	110
Metal-Panel Screw with EPDM Washer	110
Self-Drilling Hex-Washer Head Screw	111
Self-Drilling Hex-Washer Head Screw with EPDM Sealing Washer	112
Self-Drilling Flat-Pan-Head Screw	113
Pancake-Head Screw	113
PCULP Standing-Seam-Roofing Panel Clip Screw	114
PC Standing-Seam-Roofing Panel Clip Screw	114
Trim-Head Screw with EPDM Sealing Washer	115
Wire-Lath Modified Truss-Head Screw	115

Table of Contents

Truss-Head Screw	116
Pocket-Hole Screw	117
Storm-Panel Screw	118
Specialty Washer for Nail and Screw Assemblies	119
EB-TY® Hidden Deck Fasteners	120
Ipê Wood Plugs	121

Metal Screws

Strong-Drive® XE Exterior Structural Metal Screw	122
Strong-Drive® PPSD Sheathing-to-CFS Screw	123
Strong-Drive® FPHSD Framing-to-CFS Screw	124
Self-Drilling E Metal Screw	124
Self-Drilling X Metal Screw	125
PCSD Standing-Seam Roofing Panel Clip Screw	126
Self-Drilling Pancake-Head Screw	126
Self-Drilling Bugle-Head Screw	127
Self-Drilling Fiber-Cement Screw	128
Self-Drilling Flat-Head Screw with Wings	129
Self-Drilling Siding Screw	130
Self-Drilling Truss-Head Screw	131
Self-Drilling Wafer-Head Screw with Wings	131
Self-Drilling Wire-Lath Modified Truss-Head Screw	132

Parts and Accessories

Driver Bits	133
-----------------------	-----

Custom Nail Worksheet	134
---------------------------------	-----

Collated Nails and Staples

Siding/Fencing/Trim

0° Inserted Plastic Coil, Full Round Head, Ring-Shank Nail	136
15° Inserted Plastic Coil, Full Round Head, Ring-Shank Nail	137
15° Inserted Plastic Coil, White Full Round Head, Ring-Shank Nail	138
15° Wire Coil, Full Round Head, Ring-Shank Siding Nail	139
15° Wire Coil, Painted Full Round Head, Ring-Shank Nail	140

Roofing

15° Wire Coil, Full Round Head, Ring-Shank Roofing Nail	141
15° Wire Coil, Full Round Head, Smooth-Shank Roofing Nail	142

Framing

Coil	143
15° Wire Coil, Full Round Head, Ring-Shank Decking/Framing Nail	143
15° Wire Coil, Painted Full Round Head, Ring-Shank Decking/Framing Nail	144
Plastic Strip Nails	145
20–22° Plastic Strip, Casing Head, Ring-Shank Nail	145
20–22° Plastic Strip, Full Round Head, Ring-Shank Nail	146
20–22° Plastic Strip, Full Round Head, Screw-Shank Nail	147
20–22° Plastic Strip, Full Round Head, Smooth-Shank Nail	148
31–34° Plastic Strip, Full Round Head, Ring-Shank Nail	149
Wire-Weld Nails	150
28° Wire-Weld, Clipped Head, Ring-Shank Nail	150
Paper Tape Nails	151
31–34° Paper Tape, Clipped Head, Ring-Shank Nail	151

Connector Nails

Strong-Drive® 33° SCN Smooth-Shank Connector Nail	152
Strong-Drive® 33° SCNR Ring-Shank Connector Nail	152

Trim Nails

20° Angle, Adhesive Collation, T-Style Head, 16-Gauge Finishing Nail	153
25° Angle, Adhesive Collation, FN-Style, 15-Gauge Finishing Nail	154
Straight, Adhesive Collation, T-Style Head, 16-Gauge Finishing Nail	155
Straight, Adhesive Collation, T-Style Head, 18-Gauge, Brads	156
Straight, Adhesive Collation, 23-Gauge, Micro Pins	157
33° Tape Collation, DA-Style Angle, 15-Gauge Finishing Nail	158

Specialty

L Series Flooring Cleats	159
T Series Flooring Cleats	159

Staples

½" Crown, 15½-Gauge Staples	160
1" Crown, 16-Gauge Staples	160
½" Crown, 16-Gauge Staples	161
¼" Crown, 18-Gauge Staples	162
7/16" Crown, 16-Gauge Staples	163
¾" Crown, 22 Gauge Staples	164
Collated Nail: Tool Compatibility Matrix	165-168
Collated Staple: Tool Compatibility Matrix	169-170

Collated Screws for the Quik Drive® System

Application/Fastener/Tool Matrix

Collated Exterior Wood Screws

Deck-Drive™ DSV Wood Screw	174
Deck-Drive™ DWP Wood SS Screw	174
Deck-Drive™ DHPD Hardwood Screw	175
Strong-Drive® WSNTL Wood Screw	175
Trim-Head Decking Screw – Sharp Point	176
Trim-Head Decking Screw – Type-17 Point	176
SS3DSC Bugle-Head Wood Decking Screw	177
CB3BLG Fiber-Cement Board Screw	177
CB3BLGHL Cement Board Screw	178
DWC Drywall Screw	179
HJ Metal Roofing/Siding Panel Screw	180
HG Metal Roofing/Siding Panel Screw	180
Color Guide for HJ/HG	181
PC Standing-Seam-Roofing Panel Clip Screw	182
PCULP Standing-Seam-Roofing Panel Clip Screw	183
WSC Wood Screw	184
SSWSCB Roofing Tile Screw	184
WSCD Roofing Tile Screw	185
WSCT Roofing Tile Screw	185

Collated Composite Decking Screws

Composi-Lok™ Composite-Decking Screw	186
Deck-Drive™ DCSD COMPOSITE-TO-STEEL Screw	187

Table of Contents

Collated Interior Wood Screws

Strong-Drive® WSNTL Subfloor Screw	188
WSHL Subfloor Screw	190
DWC Drywall Screw	190
DWHL Drywall Screw	191
MTH Wood Underlayment Screw	191
PC Standing Seam Roofing Panel Clip Screw	192
PCULP Standing-Seam-Roofing Panel Clip Screw	192
PHSS Wood Screw	193
WSC Wood Screw	193
WSCLT Wood Screw	193

Collated Metal Screws

Strong-Drive® TB Wood-to-Steel Screw	194
Strong-Drive® PHSD Framing-to-CFS Screw	195
Strong-Drive® FPHSD Framing-to-CFS Screw	195
Strong-Drive® PPSD Sheathing-to-CFS Screw	196
Self-Drilling X Metal Screw	197
PCSD Standing-Seam Roofing Panel Clip Screw	198
CBSDQ Sheathing-to-CFS Screw	199
DWF Drywall-to-CFS Screw	200
DWFSD Drywall-to-CFS Screw	200
FHSD Wood-to-CFS Screw	201
WSFLRV Wood-to-CFS/Aluminum Screw	201

Quik Drive® Systems Applications

Subfloor/Sheathing	204-205
Decks, Docks, and Boardwalks	206-207
Drywall	208-209
Fiberglass-Mat Gypsum Sheathing	210
Fiber-Cement Siding	211-212
Standing-Seam Metal Roofing	213
Exposed-Fastener Metal Roofing/Siding	214-215
Tile Roofing	216-217
Steel Framing/Stitching	218-219
Steel Decking/Stitching	220-221
Underlayment/Backerboard	222-223
Truck Beds/Trailer Flooring	224-225
Crating	226-227
Truss-Ply Fastening	228-229
Nailers/Ledgers-to-Steel	230-231

Quik Drive® Systems

Quik Drive® Systems	234
Quik Drive® Combo Systems	235
Quik Drive® Attachments	235-236

Quik Drive Systems

BGP300 Metal-Roofing/Siding System	237
PRO200 Drywall System	238
PRO250 Subfloor System	239
PRO300S Decking System	240

PROHSD60 Wood-to-Steel System	241
PROHSD75 Wood-to-Steel System	242
PROHX14 Metal Roofing/Siding System	243
PROLDH Underlayment/Backerboard System	244
PRORF Roofing Tile System	245
PRO300SRF Roofing-Tile System	246
PROSD150 Steel-Decking System	247
PROPP150 Metal Roofing System	248

Quik Drive Attachments

PRO200 Drywall Attachment	249
PRO200S Multi-Purpose Attachment	249
PRO250 Subfloor Attachment	250
PRO250DW Drywall Attachment	250
PRO300S Decking Attachment	251
PROHSD60 Wood-to-Steel Fastening Attachment	252
PROHSD75 Wood-to-Steel Fastening Attachment	252
PROHX14 Metal Roofing/Siding Attachment	253
PROHX516 Steel-to-Steel Fastening Attachment	253
PROLDH Underlayment/Backerboard Attachment	254
PROPH Cold-Formed Steel Framing Attachment	254
PRORF Roofing Tile Attachment	255
PRO300SRF Roofing Tile Attachment	255
PROSD150 Steel-Decking Attachment	256
PROPP150 Metal Roofing Attachment	256

Quik Drive Combo Systems

PROSDD Multi-Purpose Combo System	257
PROCCS+ Multi-Purpose Combo System	258
PROCGB Underlayment/Backerboard Combo System	259

Parts and Accessories

Screwdriver Motors	260-261
Countersink and RPM Recommendations	262
Adaptors	263
Replacement Parts	264
Accessories	265
Schematics and Troubleshooting	266

Quik Drive® – Warranty	267
---	-----

Safety Warnings	268
----------------------------------	-----

Technical Information

General Material Safety Data Note	270
General Load Tables	271
Strong-Drive® SDWS Timber Screw	272
Allowable Shear Loads	272
Allowable Withdrawal Loads	272
Ledger Spacing	273
Sole-to-Rim Connections	274
Ledger-to-Stud Applications	275
Connections with Gypsum Board Interlayer(s)	276-279
Attaching foam insulation	280-281
Strong-Drive® SDWS Log Screw	282
Allowable Shear Loads	282
Allowable Withdrawal Loads	282

Table of Contents

Strong-Drive® SDWH Timber-Hex Screw 283
 Allowable Shear Loads 283
 Allowable Withdrawal Loads 283
 Ledger Spacing 284
 Sole-to-Rim Connections 285
 Ledger to Stud Applications 286
 Connections with Gypsum Board Interlayer(s) 287-290

Strong-Drive® SDWH Timber-Hex SS Screw 291
 Allowable Shear Loads 291
 Ledger Spacing 292-293

Strong-Drive® SDWC TRUSS Screw 294
 Allowable Roof-to-Wall Connection Loads 294
 Allowable Stud-to-Plate Connection Loads 295
 Allowable Shear Loads 296
 Allowable Withdrawal and Pull-Through Loads 296
 Narrow Face of Stud-to-Plate Connections 297-298
 Continuous Load Path Considerations 299
 Sole-to-Rim Connections 300

Strong-Drive® SDW Truss-Ply and EWP-Ply Screw 301
 Allowable Shear Loads 301-302
 Allowable Uniform Load to Either Outside Member 303

Strong-Drive® SDWF Floor-to-Floor Screw 304
 Installation Information 304
 Installation Conditions 305
 Uniform Uplift Loads 305
 Concentrated Uplift Loads 306

Strong-Drive® TB Wood-To-Steel Screw 307
 Allowable Loads 307

Strong-Drive® WSNTL Subfloor Screw 308
 Allowable Shear Loads 308
 Allowable Withdrawal Loads 308
 IBC Equivalent Prescriptive Fastening Schedule 309
 IRC Equivalent Prescriptive Fastening Schedule 309
 Allowable Loads Comparison 310
 Guidelines for Fastening Diaphragms without Glue 311

Strong-Drive® XE Exterior Structural Metal Screw 312
 CFS Member Connection Loads 312
 Screw Strength 312
 Allowable Loads for Connectors in Trex Elevations 312

Strong-Drive® PPSD Sheathing-to-CFS Screw 313
 Pull-Out Loads 313
 Pull-Through Loads 313

Strong-Drive® PHSD Framing-to-CFS Screw 314
 CFS Member Connection Loads 314
 Nominal Shear Strength for Wind and Seismic for Shear Walls 314

Strong-Drive® FPHSD Framing-to-CFS Screw 315
 CFS Member Connection Loads 315
 Nominal Shear Strength for Wind and Seismic for Shear Walls 315

Fastener Types for Connectors 316

Strong-Drive® SDS Heavy-Duty Connector Screw 317
 Allowable Shear Loads 317-319
 Ledger Spacing 320
 Sole-to-Rim Connections 321

Strong-Drive® SD Connector Screw 322
 Allowable Shear Loads 322
 Allowable Withdrawal Loads 322
 Approved connectors for Strong-Drive® SD Connector Screw 323

Strong-Drive® SCNR Ring-Shank Connector Nail 324
 Installation Information 324
 Nail Substitution Chart 324
 Over-driven Nails in Connectors and Straps 324

Strong-Drive® SCN Smooth-Shank Connector Nail 325
 Installation Information 325
 Characteristics needed for Smooth-Shank Nails 325
 Over-driven Nails in Connectors and Straps 325

Wafer-Head Screw 326
 Allowable Loads 326

EB-TY® Hidden Deck Fasteners 327
 Installation Information 327

Self-Drilling E Metal Screw 328
 Screw Strength 328
 CFS Member Connection Loads 328

PC/PCSD/PCULP Standing-Seam Roofing Panel Clip Screw 329
 CFS Member Connection Loads 329
 Wood Member Connection Withdrawal Loads 329
 Nominal Shear Strength for Wind and Seismic Loads Shear Walls 330

DWF/DWFSD Screws 330
 Nominal Shear Strength for Wind and Seismic Loads Shear Walls 330

PPSD/CBSDQ/FHSD/WSFLRV Screws 331
 Nominal Shear Strength for Wind and Seismic Loads Shear Walls 331

Self-Drilling X Metal Screw 332
 CFS Member Connection Loads 332

Steel-Deck Fastening 333
 Evaluation Reports and Approvals 334
 Steel-Deck Diaphragm Calculator 334

Stainless Steel Fasteners

Stainless-Steel Fasteners 336-339

Stainless Steel Fasteners

Alphabetical Index 340-354

Company Information

For more than 50 years, Simpson Strong-Tie has focused on creating structural products that help people build safer and stronger homes and buildings. A leader in structural systems research and technology, Simpson Strong-Tie is one of the largest suppliers of structural building products in the world. The Simpson Strong-Tie commitment to product development, engineering, testing and training is evident in the consistent quality and delivery of its products and services. Simpson Strong-Tie® product lines include:

- Structural connectors for wood and cold-formed-steel construction
- Strong-Wall® prefabricated shearwalls
- Strong Frame® moment frames
- Strong Rod™ systems for multi-story buildings
- Fastening systems including Quik Drive® auto-feed screw driving systems
- Simpson Strong-Tie® anchors and fasteners for concrete and masonry
- Repair, Protection, and Strengthening systems
- Integrated Component Solutions

For more information, visit the company's Web site at www.strongtie.com.



(800) 999-5099 | www.strongtie.com

All rights reserved. This catalog may not be reproduced in whole or in part without the prior written approval of Simpson Strong-Tie Company Inc.

Company Information

The Simpson Strong-Tie Company Inc. “No Equal” pledge includes:

- Quality products value-engineered for the lowest installed cost at the highest rated performance levels
- Most thoroughly tested and evaluated products in the industry
- Strategically located manufacturing and warehouse facilities
- National code agency listings
- Largest number of patented connectors in the industry
- European locations with an international sales team
- In-house R&D and tool and die professionals
- In-house product testing and quality control engineers

Member of: **AITC, ASTM, ASCE, AWPA, ACI, AISC, CSI, ICFA, NBMDA, NLBMDA, SDI, SETMA, STAFDA, SREA, NFBA, WTCA** and local engineering groups.

The Simpson Strong-Tie Quality Policy

We help people build safer structures economically. We do this by designing, engineering and manufacturing “No Equal” structural connectors and other related products that meet or exceed our customers’ needs and expectations. Everyone is responsible for product quality and is committed to ensuring the effectiveness of the Quality Management System.



Karen Colonias
Chief Executive Officer



Terry Kingsfather
President

Getting Fast Technical Support

When you call for engineering technical support, we can help you quickly if you have the following information at hand. This will help us to serve you promptly and efficiently.

- Which Simpson Strong-Tie catalog are you using? (See the front cover for the catalog number)
- Which Simpson Strong-Tie product are you using?
- What is the type and thickness of the materials you are fastening?
- What is your load requirement?
- If using a Quik Drive attachment:
 - What attachment are you using?
 - What is the RPM range of your screwdriver motor or model number?

We Are ISO 9001-2008 Registered

Simpson Strong-Tie is an ISO 9001-2008 registered company. ISO 9001-2008 is an internationally-recognized quality assurance system which lets our domestic and international customers know that they can count on the consistent quality of Simpson Strong-Tie® products and services.



Product Identification Key

Products are divided into nine general categories, identified by tabs along the page’s outer edge.

Series	26–32 ▶
Fastener Application Guide	33–56 ▶
Screws and Nails	57–134 ▶
Collated Nails and Staples	135–170 ▶
Collated Screws for the Quik Drive System	171–201 ▶
Quik Drive System Application Guide	202–232 ▶
Quik Drive Systems	233–268 ▶
Technical Information	269–334 ▶
Stainless-Steel Fasteners	335–339 ▶

Important Information Warnings and Warranties

Warning

Simpson Strong-Tie® fasteners and fastening products are designed and tested for certain applications and environments. To obtain optimal performance from Simpson Strong-Tie products, the products must be properly installed and used in accordance with the installation instructions and design limits provided by Simpson Strong-Tie Company Inc.

To ensure proper installation and use, designers and installers must carefully read the following General Notes, catalog pages for specific product installation and instructions and notes.

Proper product installation requires careful attention to all notes and instructions. Installers, designers, engineers and consumers should consult the Simpson Strong-Tie Company Inc. website at www.strongtie.com to obtain additional design and installation information, including:

- Information on workshops Simpson Strong-Tie conducts at various training centers throughout the country
- Code Reports
- Technical fliers and bulletins
- Corrosion information
- Answers to frequently asked questions and technical topics

Failure to follow fully all of the notes and instructions provided by Simpson Strong-Tie Company Inc. may result in improper installation of products. Improperly installed products may not perform to the specifications set forth in this catalog.

Simpson Strong-Tie Company Inc. does not guarantee the performance or safety of products that are modified, improperly installed or not used in accordance with the design and load limits set forth in this catalog.

Terms & Conditions of Sale

Product Use

Products in this catalog are designed and manufactured for the specific purposes shown, and should not be used for any other purposes unless approved by a qualified Designer. Modifications to products or changes in installation procedures should only be made by a qualified Designer. The performance of such modified products or altered installation procedures is the sole responsibility of the Designer.

Indemnity

Customer or Designers modifying products or installation procedures, or designing non-catalog products for fabrication by Simpson Strong-Tie Company Inc. shall, regardless of specific instructions to the user, indemnify, defend, and hold harmless Simpson Strong-Tie Company Inc. for any and all claimed loss or damage occasioned in whole or in part by non-catalog or modified products.

Non-Catalog and Modified Products

Consult Simpson Strong-Tie Company Inc. for applications for which there is no catalog product or for fasteners for use in applications not specifically listed for the product.

Non-catalog products must be designed by the customer and will be supplied by Simpson Strong-Tie Company Inc. in accordance with customer specifications.

Simpson Strong-Tie Company Inc. cannot and does not make any representations regarding the suitability of use or load-carrying capacities of non-catalog products. Simpson Strong-Tie Company Inc. provides no warranty, express or implied, on non-catalog products. F.O.B. shipping point unless otherwise specified.

Limited Warranty

This Limited Warranty must be read in conjunction with the General Notes, Corrosion Information, and Terms & Conditions of Sale.

Simpson Strong-Tie Co. Inc. ("Simpson") warrants catalog products to be free from defects in material or manufacturing. Simpson products are further warranted for adequacy of design when used in accordance with design limits in this catalog, and properly specified and installed. This warranty does not apply to products used not in compliance with specific applications and installation procedures set forth in this catalog, or to non-catalog or modified products, or to deterioration due to environmental conditions.

Simpson products are designed to the load capacities and uses listed in this catalog. Properly installed Simpson products will perform in accordance with the specifications set forth in the applicable Simpson Strong-Tie® catalog. Additional performance limitations for specific products may be listed on the applicable catalog pages.

Due to the particular characteristics of potential impact events, the specific design and location of the structure, the building materials used, the quality of construction, and the condition of the soils involved, damage may nonetheless result to a structure and its contents even if the loads resulting from the impact event do not

Warranties (cont.) and General Notes

exceed Simpson Strong-Tie catalog specifications and Simpson Strong-Tie® products are properly installed in accordance with applicable building codes. All warranty obligations of Simpson shall be limited, at the discretion of Simpson to repair or replacement of the defective part(s). These remedies shall constitute Simpson's sole obligation and sole remedy of purchaser under this warranty. This warranty may change periodically — consult this website for current information.

SIMPSON DISCLAIMS ALL OTHER WARRANTIES, EXPRESS OR IMPLIED, INCLUDING BUT NOT LIMITED TO IMPLIED WARRANTIES OF MERCHANTABILITY AND FITNESS FOR A PARTICULAR PURPOSE. IN NO EVENT WILL SIMPSON BE LIABLE FOR INCIDENTAL, CONSEQUENTIAL, PUNITIVE OR SPECIAL DAMAGES OR DIRECT OR INDIRECT LOSS OF ANY KIND, INCLUDING BUT NOT LIMITED TO PROPERTY

DAMAGE AND PERSONAL INJURY. SIMPSON'S ENTIRE LIABILITY IS LIMITED TO THE PURCHASE PRICE OF THE PRODUCT. SOME STATES DO NOT ALLOW LIMITATIONS ON IMPLIED WARRANTIES, OR THE EXCLUSION OR LIMITATION OF INCIDENTAL OR CONSEQUENTIAL DAMAGES, SO THE ABOVE LIMITATIONS AND EXCLUSIONS MAY NOT APPLY TO YOU. THIS LIMITED WARRANTY GIVES YOU SPECIFIC LEGAL RIGHTS, AND YOU MAY ALSO HAVE OTHER RIGHTS THAT VARY FROM STATE TO STATE.

General Notes

These notes are provided to ensure proper selection and installation of Simpson Strong-Tie Company Inc. products and must be followed carefully

- a. Simpson Strong-Tie Company Inc. reserves the right to change specifications, designs and models without notice or liability for such changes.
- b. Do not exceed published loads, doing so could jeopardize the connection.
- c. A fastener that splits the wood will not take the design load. Evaluate splits to determine if the connection will perform as required. Dry wood may split easily and should be evaluated as required. If wood tends to split consider pre-boring holes with diameters specified in the 2005 and 2012 Editions National Design Specification (NDS) sections 11.1.6 for nails and 11.1.5 for screws.
- d. Unless otherwise noted, dimensions are in inches, loads are in pounds and shear loads are applied perpendicular to edge.
- e. Unless otherwise noted, nail "penny size" does not imply specific diameters or load capacities. Design standards must be used in conjunction with fastener material, diameter and length to determine acceptable uses.
- f. Dissimilar metal combinations should be carefully assessed and avoided if possible.
- g. Fasteners may break if driven into hard materials or if countersunk below the surface of the substrate fastened.
- h. All carbon steel based fasteners have the potential to corrode and rust.
- i. Use Quik Drive® tools only with authentic Quik Drive fasteners. Other fasteners will void the warranty and may cause the tool to malfunction and become damaged.
- j. If a Quik Drive product is compatible with a specified tool, do not use the product with any other tool.
- k. Do not overdrive fasteners. Overdriven fasteners may have a reduction in shear and pull-through capacity.
- l. Some hardened fasteners may have premature failure if exposed to moisture. These fasteners are recommended to be used in interior dry conditions.
- m. Pneumatically driven fasteners may deflect and injure the operator or others. Follow the tool manufacturer's operating instructions and use appropriate safety equipment.
- n. Choose the proper tool to suit the fastener and applications.
- o. Use products only in accordance with all instructions.
- p. All specified fasteners must be installed according to the instructions in this catalog.
- q. Use proper safety equipment and follow all safety instructions.
- r. Always wear protective eyewear.
- s. There are many choices of fasteners, tools and other products. It is often difficult to determine which type of product is best suited for your application. In some cases, there may be more than one type of product that will work well. The information in this catalog is intended to guide the Designer toward the product best suited for the specific application, use and environment. The choice of which product to use should be made by a qualified Designer.
- t. All connected members and related elements shall be designed by the Designer.
- u. Select fasteners of a type, size, length, thread, head, coating, material, point and other characteristics suitable for your application, use and environment. Incorrect fastener selection may cause the connection to fail.
- v. Select a fastener only after reading the corrosion information on page 15 of this catalog.
- w. If using a fastener from this catalog with any other Simpson Strong-Tie product, consult the appropriate Simpson Strong-Tie catalog or www.strongtie.com for detailed information concerning the other product.

Important Information and General Notes

- x. Only use fasteners for their intended purpose as described in this publication. Connection failures can result from inappropriate substitution.
- y. Be aware of special conditions that may increase corrosion risk and select product accordingly.
- z. Test drive fasteners to assure fasteners install correctly.
 - aa. With the use of any power or pneumatic tools, follow manufacturer's safety instructions.
 - ab. Screws made from austenitic stainless steel are generally softer and have less torsional strength than screws made from carbon steel. Simpson Strong-Tie does not assume liability for breakage or damage due to screw breakage during or after installation. Pre-drilling may be necessary in some case. For best results, drive at 2500 RPM or less.
 - ac. The term "Designer" used throughout this catalog is intended to mean a licensed/certified building design professional, a licensed professional engineer or licensed architect.
 - ad. Follow material manufacturer's installation instructions and fastener recommendations.
 - ae. This catalog includes all information available as of the effective date of publication. Please consult www.strongtie.com for current information.

Deck Construction and Fastening Tips

- Before beginning construction, allow your decking materials to acclimate to the jobsite conditions. A freshly pressure treated deck board can contain over a gallon of liquid.
- Select the proper fastener based on your application, environment and the material that is being fastened. Consult page 15 of C-F-14, or www.strongtie.com/info for guidelines on choosing the correct fastener.
- Consider using 300 series stainless-steel fasteners when unusual exposure conditions may exist, such as presence of de-icing salts or close proximity to swimming pools, hot tubs, sprinklers, ponds, foliage and other resident moisture sources.
- Inadequate gap spacing between boards can put additional load on the fasteners and lead to broken screws or nail pops.
- Orienting the crown of the deck board "bark side up" will help to shed water and reduce cupping and other weathering-related defects
- Use caution to avoid overdriving fasteners during installation, which can cause breakage.
- Allow for proper water drainage. A deck should angle away from the structure a minimum of 1/8" for every 8' to reduce the possibility of standing water.
- If your 5/4" decking is to be installed diagonally, reduce the on-center joist spacing to 12" versus standard 16".
- Adequate ventilation is necessary to minimize cupping, warping and other weathering related defects. Construct the deck a minimum of 18 inches off the ground to allow proper airflow. If this is not possible, reduce on-center joist spacing to 12" versus standard 16". A moisture barrier (landscape fabric) under the deck, covered with gravel is also a good practice.
- Proper maintenance is essential. Staining and sealing, along with periodic inspection of fasteners and hardware, will potentially add years to the life of the deck.

For more information on deck construction and products from Simpson Strong-Tie; please see our Deck Connection and Fastening Guide (F-DECKCODE).

Please refer to the American Wood Council's Prescriptive Residential Wood Deck Construction Guide (DCA 6) for important information on best practices and code compliant design.

Corrosion Information

Understanding the Corrosion Issue

Many environments and materials can cause corrosion including ocean salt air, fire-retardants, fumes, fertilizers, preservative-treated wood, de-icing salts, dissimilar metals and more. Metal fasteners could corrode and lose load-carrying capacity when installed in corrosive environments or when installed in contact with corrosive materials.

The many variables present in a building environment make it impossible to accurately predict if, or when, corrosion will begin or reach a critical level. This relative uncertainty makes it crucial that specifiers and users are knowledgeable of the potential risks and select a product suitable for the intended use. It is also prudent that regular maintenance and periodic inspections are performed especially for outdoor applications.

It is common to see some corrosion in outdoor applications. Even stainless steel can corrode. The presence of some corrosion does not mean that load capacity has been affected or that failure is imminent. If significant corrosion is apparent or suspected, then the wood, fasteners and connectors should be inspected by a qualified engineer or qualified inspector. Replacement of affected components may be appropriate.

Some wood-preservative chemicals and fire retardant chemicals and retentions pose increased corrosion potential and are more corrosive to steel connectors and fasteners than others. Testing by Simpson Strong-Tie has shown that ACQ-Type D is more corrosive than Copper Azole Type C, Micronized Copper Azole, and CCA-C. At the same time, others have shown that the inorganic boron treatment chemicals, specifically SBX-DOT, is less corrosive than CCA-C.

Due to the many different chemical treatment formulations, chemical retention levels, moisture conditions and regional formulation variants, selection of fasteners has become a complex task. We have attempted to provide basic knowledge on the subject here, but it is important to fully educate yourself by reviewing our technical bulletins on the topic (www.strongtie.com/info) and also by reviewing information, literature and evaluation reports published by others.

Treatment Use Categories and Exposure Conditions

The American Wood Protection Association (AWPA) identifies 12 Use Category designations (UC) for wood treatment chemicals that are based on protection of the wood material; the Use Categories are based on service conditions and environments and agents of deterioration. At the same time, the building codes require specific corrosion resistance for fasteners that are in contact with chemically treated wood, and the corrosion resistance is independent of the service environments and treatments that are the basis of the AWPA Use Categories. From the building code perspective, fastener corrosion resistance is provided by hot-dip galvanization applied following ASTM A153, Class D or a corrosion resistant base metal, such as stainless steel, silicon bronze or copper regardless of exposure.

Some exceptions are provided in the International Code Council's (ICC) International Residential Code (IRC) for mechanical galvanization applied to screws.

The International Code Council — Evaluation Service (ICC-ES) implemented AC257 as a method to evaluate alternate corrosion resistance mechanisms for fasteners used in wood construction where hot-dip galvanization (ASTM A153, Class D) is used as the benchmark performance. Under AC257, fastener corrosion resistance is qualified for one or more of four exposure conditions with no salt exposure: (1) treated wood in dry-service; (2) clean wood in a salt air dry-service environment; (3) treated wood in a wet-service condition; with no salt exposure; and (4) general use with no limitations.

Corrosion Information (cont.)

Simpson Strong-Tie General Recommendations

Simpson Strong-Tie has evaluated the AWWA Use Categories (AWPA U1-13) and the ICC-ES, AC257 Exposure Conditions and developed from that evaluation a set of Corrosion Resistance Recommendations. These recommendations address the coating systems and materials used by Simpson Strong-Tie for fastener products.

Dry-service (or damp-service) environments lead to wood moisture contents less than or equal to 19%. The corrosion potential, even in chemically treated wood, is reduced in these conditions. These conditions are typical of AWWA UC1 and UC2 for wood treatment and AC257 Exposure Condition 1. See the Corrosion Resistance Classification Table for the Simpson Strong-Tie assessment of corrosion needs in these conditions. The AC257 Exposure Condition 2 reflects the presence of air-borne salt in a dry-service environment and corrosion hazard to exposed metal surfaces; it does not include effects of treatment chemicals.

Outdoor environments are generally more corrosive to steel either because the moisture exposure is elevated (greater than 19%) and/or the treatment chemical retention level is higher than for interior service. The AWWA classifies exterior above ground treatments as Use Categories UC3 (A and B) depending on moisture run-off; and for ground-contact levels of protection, it has Use Categories UC4 (A-C). ICC-ES considers the exterior exposure to be limited by the type of chemicals and retention level of the chemicals in the qualification testing and whether the exposure includes salt exposure. In general, The AC257 Exposure Condition 3 includes AWWA Use Categories UC1 (interior dry) to UC4A (exterior ground contact, general use).

Types 316/305/304 stainless steel, copper, silicon bronze and hot-dip galvanized (Class-C) are the most effective protection against corrosion risk, where Type 316 is the best choice for salt marine and chloride containing environments regardless of treatment chemicals or wood species. If you choose to use hot-dip galvanized (Class-D), mechanically galvanized

(C3, N2000, or Class 55), double-barrier or Quik Guard coated fasteners on outdoor projects (e.g., a deck), you should periodically inspect the fasteners or have a professional inspection performed, and regular maintenance is a good practice. See the Corrosion Resistance Classifications Table for the Simpson Strong-Tie assessment of the corrosion resistance associated with materials and coatings and an appropriate level of corrosion resistance for various environments.

Due to the many variables involved, Simpson Strong-Tie cannot provide estimates of service life of connectors and fasteners. We suggest that all users and specifiers obtain recommendations on corrosion from the treated wood supplier or for the type of wood used. As long as Simpson Strong-Tie recommendations are followed, Simpson Strong-Tie stands behind its product performance and our standard warranty applies (page 10-11).

Simpson Strong-Tie does not recommend painting stainless steel fasteners or hardware. The reason behind this recommendation is that sometimes painting can facilitate corrosion. Stainless steel is “stainless” because it forms a protective chromium oxide film on the surface by passive oxidation with air. The paint film on the stainless steel surface may be imperfect or it can be injured during service, and in either case the metal may be exposed. Microscopic-sized film imperfections and scratches facilitate collection of dirt and water that can be stagnant and degrade or block the passive formation of the protective chromium oxide film. When this happens, crevice corrosion can initiate. Crevice corrosion eventually becomes visible as a brown stain or as red rust. This is the reason that painting usually does not improve corrosion resistance of stainless steel.

Corrosion Information (cont.)

Guidelines for Selecting Corrosion-Resistant Fasteners

Evaluate the Application.

Consider the importance of the connection.

Evaluate the Exposure.

Consider these moisture and treatment chemical exposure conditions:

- Dry service: Generally INTERIOR applications and includes wall and ceiling cavities, raised floor applications in enclosed buildings that have been designed to prevent condensation and exposure to other sources of moisture.
- Wet Service: Generally EXTERIOR construction in conditions other than Elevated Service. These include Exterior Protected and Exposed and General Use Ground Contact as described by the AWWA UC4A.
- Elevated Service: Includes fumes, fertilizers, soil, some preservative-treated wood (AWPA UC4B and UC4C), industrial zones, acid rain and other corrosive elements.
- Uncertain: Unknown exposure, materials, or treatment chemicals.
- Ocean/Water Front: Marine environments that include airborne chlorides and some splash. Environments with de-icing salts are included.
- Treatment Chemicals: See AWWA Use Category Designations. The preservative-treated wood supplier should provide all of the pertinent information about the wood being used. The information should include Use Category Designation, wood species group, wood treatment chemical, and chemical retention. See appropriate evaluation reports for corrosion effects of treatment chemicals and fastener corrosion resistance recommendations.

Use the Simpson Strong-Tie® Corrosion Classification Table.

If the treatment chemical information is incomplete, Simpson Strong-Tie recommends the use of a 300 series stainless steel product. Also if the treatment chemical is not shown in the Corrosion Classification Table, then Simpson Strong-Tie has not evaluated it and cannot make any recommendations other than the use of coatings and materials in the Severe category. Manufacturers may independently provide test results of other product information; Simpson Strong-Tie expresses no opinion regarding such information.

Corrosion Resistance Recommendations			
Low	Medium	High	Severe
Phosphate (gray, black), Clear (bright) zinc (ASTM F1941), Heavy Electro-galvanized (ASTM A641-Class 1), Yellow zinc (ASTM F1941), Electrocoat (E-coat), Type 410 stainless steel	Mechanically galvanized (AS 3566.2-C3, N2000, ASTM B695-Class 55), Quik Guard® coating, Hot-dip galvanized (ASTM A153-Class D), Double-Barrier coating	Type 304 stainless steel, Type 305 stainless steel	Type 316 stainless steel, Hot-dip galvanized (ASTM A153-Class C), Silicon Bronze, Copper

Corrosion Resistance Classifications							
Environment	Material to be Fastened						
	Untreated Wood or Other Material	Preservative-treated Wood					FRT Wood
		SBX-DOT Zinc Borate	Chemical Retention ≤ AWWA, UC4A	Chemical Retention > AWWA, UC4A	ACZA	Other or Uncertain	
Dry Service	Low	Low	Low	High	High	High	Med
Wet Service	Med	N/A	Med	High	High	High	High
Elevated Service	High	N/A	Severe	Severe	High	Severe	N/A
Uncertain	High	High	High	Severe	High	Severe	High
Ocean/Water Front	Severe	N/A	Severe	Severe	Severe	Severe	N/A

1. These are general guidelines that may not consider all application criteria. Refer to product specific information for additional guidance.
2. Type 316/305/304 stainless steels are recommended where preservative-treated wood used in ground contact has a chemical retention level equal to or greater than those for AWWA UC4A: CA-C, 0.1 pcf; CA-B, 0.21 pcf; micronized CA, 0.20 pcf; ACQ-Type D (or C), 0.40 pcf.
3. Testing by Simpson Strong-Tie following ICC-ES AC257 showed that mechanical galvanization (ASTM B695, Class 55), Quik Guard coating, and Double Barrier coating will provide corrosion resistance equivalent to hot-dip galvanization (ASTM A153, Class D) in contact with chemically treated wood in dry service and wet service exposures (AWPA UC1-UC4A, ICC-ES AC257 Exposure Conditions 1 and 3) and will perform adequately subject to regular maintenance and periodic inspection.
4. Mechanical galvanizations C3 and N2000 should not be used in conditions that would be more corrosive than AWWA UC3A (exterior, above ground, rapid water run off).
5. If uncertain about Use Category, treatment chemical, or environment, use Types 316/305/304 stainless steel, silicon bronze or copper.
6. Some treated wood may have excess surface chemicals making it potentially more corrosive than lower retentions. If this condition is suspected, use Type 316/305/304 stainless steel, silicon bronze, or copper fasteners.
7. Type 316 stainless steel, silicon bronze, and copper fasteners are the best recommendation for ocean salt-air and other chloride-containing environments. Hot-dip galvanized fasteners with at least ASTM A153, Class C protection can also be an alternate for some applications in environments with ocean air and/or elevated wood moisture content.

Interior Dry

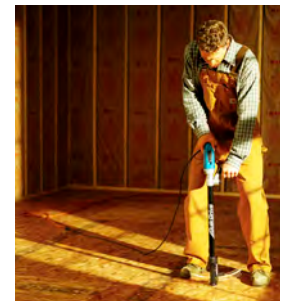

Exterior

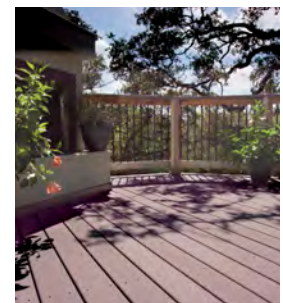

Higher Exposure



Coatings and Materials

Simpson Strong-Tie® fasteners feature a wide range of materials and coatings designed to meet specific performance criteria. It is important to select a material and/or coating that is suitable for the intended application and environment based upon factors such as corrosion resistance and mechanical properties of the material. Please see page 15 for more information on selecting fasteners based upon corrosion resistance.

Simpson Strong-Tie Company Inc. welcomes the opportunity to provide assistance in fastener selection, please call (800) 999-5099 in the event that technical support is needed.

Low Level of Corrosion Resistance



Clear Zinc

Electroplated clear zinc is applied in accordance with ASTM F1941. In the ASTM B117 salt spray test, clear zinc provides 36 hours of protection before the first appearance of red rust.

Electrocoating (E-Coat™)

Electrocoating utilizes electrical current to deposit the coating material on the fastener. After application, the coating is cured in an oven. Electrocoating provides a minimum amount of corrosion protection and is intended for dry, non-corrosive applications only.

Gray Phosphate

Gray phosphate provides a minimum amount of corrosion protection and is intended for dry, non-corrosive applications only.

Black Phosphate

Black phosphate provides a minimum amount of corrosion protection and is intended for dry non-corrosive applications only.

Heavy Zinc Electroplate

Electroplated zinc applied to a thickness in accordance with ASTM A641 (Class 1).

Yellow Zinc

Electroplated zinc applied in accordance with ASTM F1941. In the ASTM B117 salt spray test, yellow zinc provides 24 hours of protection before the first appearance of red rust.

Type 410 Stainless Steel

Type 410 stainless steel is a low-carbon martensitic grade of stainless steel that can be hardened and is inherently magnetic. This material resists corrosion in mild atmospheres and many mild chemical environments.

Medium Level of Corrosion Resistance



Quik Guard® Coating

Quik Guard is a proprietary coating that consists of an electrodeposited base layer with organic paint layer that provides equivalent protection to hot-dip galvanization in some exposures. In ASTM B117 salt spray test at 1000 hours of exposure, Quik Guard coating has an average 1.9% red rust.

Double-Barrier Coating

The Simpson Strong-Tie® double-barrier coating is a proprietary two-layer coating that provides a level of corrosion protection that is equivalent to ASTM A153 hot-dip galvanization in most non-marine exposures.

Class D Hot-Dip Galvanized, ASTM A153

Hot-dip galvanization that meets the standards of ASTM A153. Hot-dip galvanized fasteners have a minimum of 1.0 oz/ft² of zinc coating. Hot-dip galvanized fasteners are in compliance with the 2006, 2009, and 2012 International Building Code and the 2006, 2009, and 2012 International Residential Code.

Class 55 Mechanically Galvanized, ASTM B695

Mechanically-applied zinc in accordance with ASTM B695, Class 55 with a supplementary overcoat. Mechanically galvanized, Class 55 Mechanically galvanized screws are in compliance with the 2006, 2009, and 2012 International Residential Code.

N2000® Mechanically Galvanized

Mechanically applied proprietary zinc coating with supplementary overcoat. In ASTM B117 salt spray tests at 1000 hours of exposure, mechanical galvanization has an average 15% red rust.

C-3 Mechanically Galvanized

Mechanically-applied zinc with a minimum of 20% tin in accordance with Australian Standard AS3566.2. In ASTM B117 Salt spray after 1000 hours of exposure, C3 mechanically galvanized has an average 1.9% red rust.

Teal-Arrow Icon

Throughout this catalog this icon identifies coated fasteners that Simpson Strong-Tie classifies as possessing a medium level of corrosion resistance, making them suitable for use in some corrosive environments and with some preservative-treated woods. For

applications in higher-exposure applications, Type-300 series stainless-steel fasteners should be considered for superior corrosion resistance. Additional important information on page 15 should be reviewed before selecting a fastener for a specific application.

Coatings and Materials

High Level of Corrosion Resistance



Types 304 and 305 Stainless Steel

Types 304 and 305 stainless steels are nickel chromium austenitic grades of stainless steel and are inherently non-magnetic. Fasteners made from Types 304 and 305 stainless steel are compliant with the 2006, 2009, and 2012 International Building Code, section 2304.9.5 and the International Residential

Code 2006, Section R319.3 and 2009 and 2012, section R317.3.

Types 304 and 305 stainless steel are not hardened by heat treatment and provide very good corrosion protection.

Severe Level of Corrosion Resistance

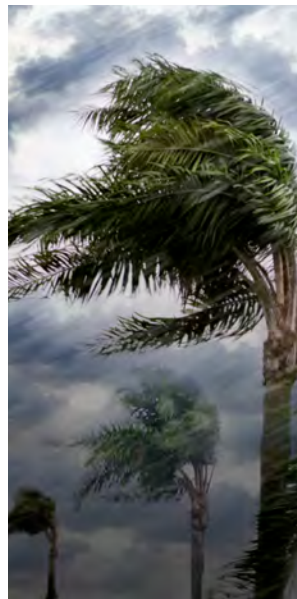

Type 316 Stainless Steel

Type 316 stainless steel is a nickel chromium austenitic grade of stainless steel with 2-3% molybdenum and is inherently non-magnetic. Fasteners made from Type 316 stainless steel are compliant with the 2006, 2009, and 2012 International Building Code, section 2304.9.5 and the International Residential Code 2006, Section R319.3 and 2009 and 2012, section R317.3.

Type 316 stainless steel is not hardened by heat treatment and provides the highest level of corrosion protection available, especially in environments with chlorides.

(2304.9.5) 2009 and 2012 International Residential Code (R317.3) and the 2009 International Building Code (2304.9.5.1)

Copper

The copper used for the manufacture of fasteners contains a minimum of 98% copper in accordance with ASTM F1667. Fasteners made from Copper are compliant with the 2006, 2009, and 2012 International Building Code, section 2304.9.5 and the International Residential Code 2006, Section R319.3 and 2009 and 2012, section R317.3.

Class C Hot-Dip Galvanized, ASTM A153

Hot-dip galvanization that meets the requirements of ASTM A153, Class C. Hot-dip galvanized fasteners have a minimum average of 1.25 oz/ft² of zinc coating. Hot-dip galvanized fasteners are compliant with the 2006 and 2012 International Residential Code (R319.3), 2006 International Building Code

Silicon Bronze

Silicon Bronze is a copper alloy with silicon used as an alloying element. Fasteners made from Silicon Bronze are compliant with the 2006, 2009, and 2012 International Building Code, section 2304.9.5 and the International Residential Code 2006, Section R319.3 and 2009 and 2012, section R317.3.

General note about salt spray testing

Salt spray testing in accordance with ASTM B117 is not intended to represent real-world corrosion performance of fastener coatings. It should only be used for comparative evaluation between like products. Many variables may affect the outcome of the salt spray test such as base material, fastener features, coating and the material where it is installed.

Trademark Attribution

4-Cut®, Accuset®, AEG®, Aircor®, Airy®, Akuzuki®, Apach®, Archer®, Arrow®, Atro®, Atlas Copco®, BeA®, Besco®, Black & Decker®, Bosch®, Bostitch®, Cadex®, Campbell Hausfeld®, Central Pneumatic®, Chicago Pneumatic®, Craftsman®, Craftex®, DeWalt®, Duo-Fast®, Eagle®, EB-TY®, E-Coat®, E-Z Fasten®, Fasco®, Freeman®, Grex®, Grip-Rite®, Grizzly®, Haubold®, HighPro®, Hilti®, Hitachi®, ISM®, Jamerco®, Makita®, Max®, Maxus®, Leland Master Gripper™, Metabo®,

Milwaukee®, Mylar®, N2000®, Northern Tool®, Numax®, Palmgren®, Paslode®, Phillips®, Pneutools®, Porta-Nails®, Porter Cable®, Powernail®, Prebena®, Primeair®, Primatch®, Porter Cable®, Ramsond®, Rigid®, Senco®, Sioux®, Snap-On®, Spotnails®, Stanley®, Stan-Tech®, Supco®, Superior®, Surebonder®, Trex®, Trex Elevations and Trex Transcend®, Wen® and Westward® are registered trademarks of their respective companies.

Fastener Overview, Nails

Nail Sizes

The most common method used to represent nail sizes is the penny size, which is a length designation. The size is written with a number and the abbreviation “d” for “denarius” which is Latin for penny. While referring to penny size and type designations such as “box” or “common” is a typical method for calling out nails, it is more accurate and reduces potential confusion if the nail is called out by diameter and length.

Nail Penny Size Lengths

Nail Size	Length	
	in.	mm
2d	1.00	25.4
3d	1.25	31.7
4d	1.50	38.1
5d	1.75	44.4
6d	2.00	50.8
7d	2.25	57.1
8d	2.50	63.5
9d	2.75	69.8
10d	3.00	76.2
12d	3.25	82.5
16d	3.50	88.9
20d	4.00	101.6
30d	4.50	114.3
40d	5.00	127.0
50d	5.50	139.7
60d	6.00	152.4
70d	7.00	177.8

Steel Wire Gauge/Diameter

Gauge	in.	mm
3	0.259	6.57
4	0.238	6.05
6	0.203	5.16
8	0.162	4.12
9	0.148	3.76
10	0.131	3.33
11	0.120	3.05
12	0.113	2.85
13	0.092	2.34
14	0.083	2.11
15	0.072	1.83
16	0.065	1.65
18	0.049	1.25
23	0.026	0.66

1. Table based on Birmingham or Stub's Iron Wire Gauge.

Fastener Overview, Nails (cont.)

Nail Types

Box: Bright, coated, plain-shank nail or regular stock steel with flat round head and medium diamond point. Shank diameter is smaller than common nails of the same penny weight.

Brads: A common term used for nails less than 1 ¼" in length with a head slightly larger than the shank. These nails can be easily concealed by countersinking below the work surface.

Casing: A wire nail with a head that is only slightly larger than a finish nail, often used for flooring.

Common: Bright plain-shank nail of regular stock steel with flat round head and medium diamond point. Shank diameter is larger than box nails of the same penny size.

Finishing: A wire nail with a head that is only slightly larger than the shank and medium diamond point. These nails can be easily concealed by countersinking below the work surface.

Roofing: A nail used for attaching paper or shingles to roof battens or sheathing; usually with a large flat head.

Siding: A wire nail with a shank that is typically 0.099" or less in diameter and a smaller head than other nails of the same size to help conceal the fastener after installation.

Nail Shank Types

Smooth Shank: There are no deformations on the shank, making nails with a smooth shank the easiest to drive. Smooth shank nails offer the least pull-out resistance when compared with spiral and ring shanks.

Spiral Shank: A spiral "thread" on the shank causes the nail to spin during installation, creating a thread-like interlock with the wood, which increases withdrawal capacity. Spiral-shank nails are designed to drive easier into harder woods and dense materials while still providing increased withdrawal resistance.

Annular Ring Shank: Annular threads or "rings" are formed on the shank to increase withdrawal capacity. The "rings" create an interlock between the shank of the nail and the wood, providing superior holding power. Generally considered the nail type with the best withdrawal resistance.



Smooth Shank



Spiral Shank



Annular Ring Shank

Color Guide for PVC/Composite Decking

PVC Decking Manufacturers Color Guide

Simpson Strong-Tie Fastener Colors	AZEK	Cevn	Gossen	Timber Tech	Trex	VekaDeck
Brown 02	Kona, Acacia	Canyon Brown, Rustic Walnut	—	Walnut Grove	—	—
Brown 03	Morado	Warm Walnut	Spanish Walnut	Rustic Bark	—	Cayenne
Brown 04	Sedona, Silver Oak	Summer Sand	—	—	—	—
Acorn	—	—	—	—	Acorn	—
Red 02	Redland Rose	Fireside	Tuscan Cherry	—	—	Walnut
Tan 02	Brownstone, Silver Oak	—	Desert Beige, Canyon Brown	Sandridge	—	Mocha
Tan 03	Fawn	Terra Cotta	—	Mountain Cedar	—	—
Tan 04	Cobre, Modena	Amber Wood	Moroccan Cedar	Harvest Bronze	—	—
Tan	—	—	—	—	—	—
Sahara	—	—	—	—	Sahara	—
Gray	Tahoe	—	London Grey	—	—	—
Gray 02	Slate	Driftwood, Weathered Wood	Harbor, Cape Cod Grey	River Rock, Harbor Stone	—	Gray
Gray 03	Clay	—	Island Sand	—	—	Khaki
Pewter	—	—	—	—	Pewter	—
White 01	White	—	—	—	—	White
White 02	Ivory	—	Seaside Sand	—	—	Almond

Color Guide for PVC/Composite Decking (cont.)

Composite or Encapsulated-Decking Color Guide

Simpson Strong-Tie Fastener Colors	ChoiceDek	Evergrain	Fiberon	Moisture Shield	Timber Tech	Trex
Acorn	—	—	—	Earthtone	Cedar	Beach Dune
Brown	—	Weathered Wood	—	—	—	Woodland Brown
Brown 01	—	Weathered Wood, Rustic Walnut	Tudor	Walnut	—	Vintage Lantern
Red	—	Redwood	—	Terracotta	Redwood	Madeira
Red 01	Coastal Redwood	Shaded Auburn	—	—	Mocha, Pacific Rosewood, Brick	Fire Pit, Lava Rock
Redwood	—	—	—	Seasoned Mahogany	Pacific Rosewood	Madiera
Tan	—	Cedar	—	—	Cedar	Saddle
Tan 01	Harvest Brown	Spiced Teak	Ipê	Tigerwood	Pacific Walnut, Brownstone, Tigerwood, Pecan, Oak, Pacific Walnut	Tree House, Spiced Rum, Barrel, Saddle
Tan	—	—	—	—	—	—
Tan 02	—	—	—	—	—	Tiki Torch, Rope Swing
Tan 03	—	Cedar	Ipê	—	Pacific Teak	Tiki Torch
Gray	Gray	Grey Wood Cape Cod	Greystone	Cape Cod Grey	Silver Maple, Grey, Slate	Accents Winchester Gray, Pebble Grey, Clam Shell
Gray 01	Beach House Grey	—	Grey Wood, Castle	—	—	Gravel Path
Gray 04	—	—	—	—	—	Select Winchester Grey, Flint

Fastener Overview, Screw Features

Head Styles

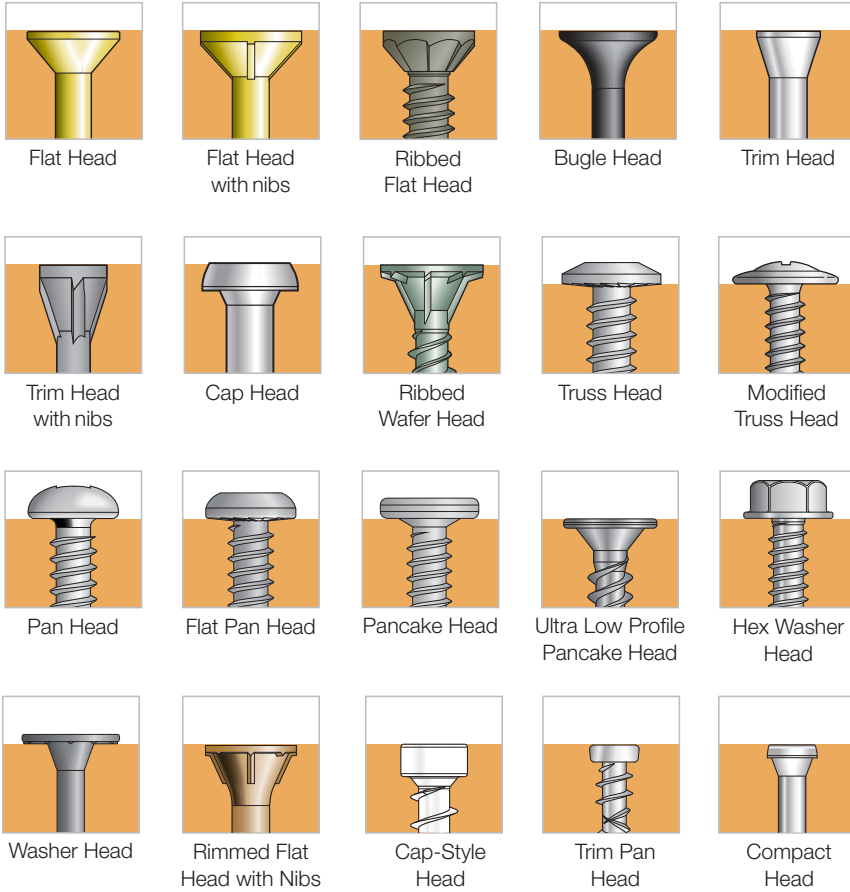

Thread Styles

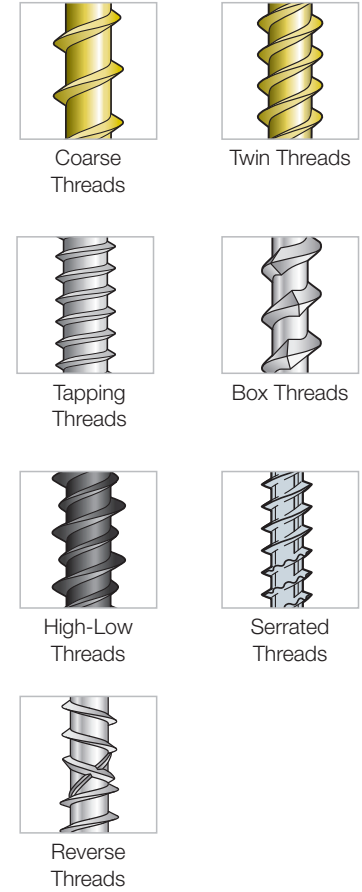

Point Styles

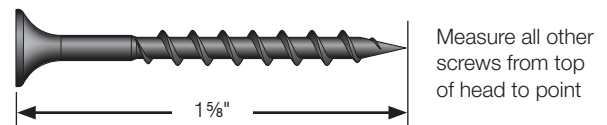
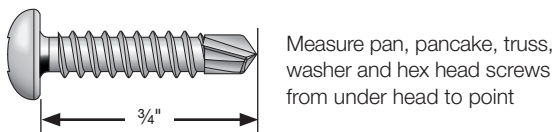
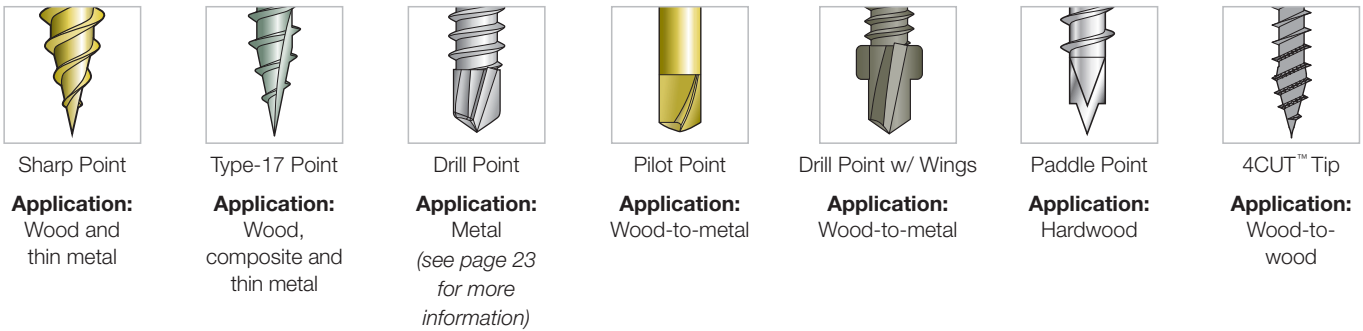

How Self-Drilling Screws Work

As their name implies, self-drilling screws operate on the same principles as drill bits and other cutting tools. This means that the way these screws are used affects their performance as much how they are designed.

For cutting tools, the governing factors of material removal are cutting speed, feed rate, depth of cut, and the work material itself. However, for self-drilling screws, these factors are determined by drill-point material and high temperature stability. This is because a self-drilling screw drill-point is generally plain carbon steel, which is less stable at high temperature than equivalent high-speed steel drill-bits; and the temperature stability affects the time to drill-point failure when cutting harder material. Finally, installation time is affected by both drill motor RPM and the applied force.

Additional Considerations

Screw Drill-Point Material: Typically plain carbon steel which is less stable at high temperature than equivalent high-speed steel (HSS) drill-bits.

Reduced Screwdriver-Motor RPM: This may actually decrease installation time by allowing greater applied force per revolution.

Definitions

RPM (Revolutions Per Minute): The speed at which the screwdriver motor runs while the screw is installed. This is often adjustable using a variable-pull trigger or different driver motor.

Applied Force: A measure of how hard the user pushes as the screw is installed.

Work Material Hardness: Can be viewed as a material's resistance to drilling or cutting. In most instances, the harder the work material, the harder it is to cut. Depending on the application, this may be outside the user's control.

When selecting a self-drilling screw design, it is important to consider the material thickness and type of materials to be joined: Key design features to consider when selecting a suitable fastener for a specific application.

Drill Flute

The flutes allow drilled material to exit the hole. The chips contain about 80% of the heat created by the drilling process. Failure to extract the chips from the drilling operation will cause the point to overheat and fail.

Point Length

The length of the drill point determines the material thickness which the screw can reliably penetrate. The unthreaded portion of the point, known as the pilot section, must be long enough to completely drill through the material before the threads engage. Since the threads advance faster than the drilling process, if they engage before drilling is done, the fastener can bind and break.

Fastening Thicker Material to Metal

When fastening thicker materials, such as wood, to metal it is necessary to use a fastener with "wings" on the shaft or a pilot point. These fasteners are designed to prevent separation of the fastened material from the base metal, a condition known as "jacking." Once the wings contact the metal they break away before the threads engage.

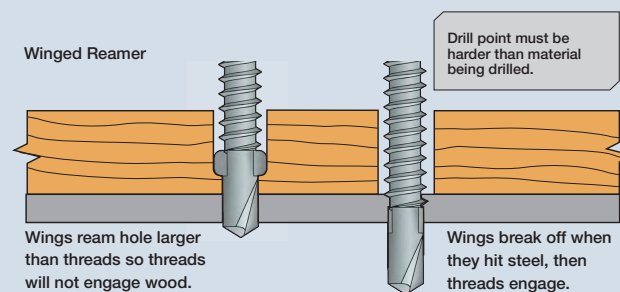
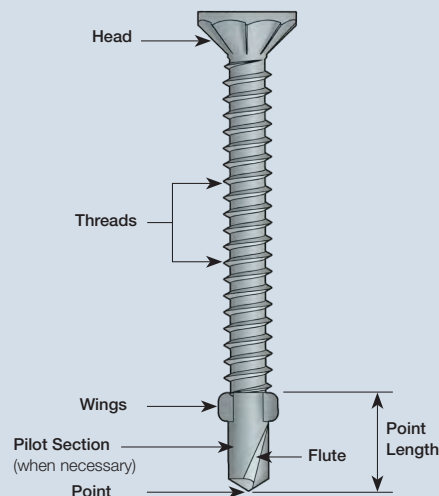

Optimal Cutting Speed by Screw Size

Screw Size	Major Diameter		RPM*	Applied Force*		Work Material Hardness*
	(in)	(mm)		(lb)	(N)	
#6	0.138	3.51	2200	80	356	20 Rockwell "C"-scale
#8	0.164	4.17	1900	93	414	
#10	0.190	4.83	1600	104	463	
#12	0.216	5.49	1400	116	516	
#14	0.250	6.35	1200	131	583	
#16	0.313	7.95	1000	157	698	

* Suggested maximum values. Stated speeds may require a variable-speed screwdriver motor and a partial trigger-pull.

How Self-Drilling Screws Work (cont.)

Screw Suitability

Screw Point Type	Screw Size	Maximum Material Thickness ^{1,2}	
		(in)	(mm)
#2	#6	0.100	2.54
	#8	0.100	2.54
	#10	0.100	2.54
#3	#7	0.125	3.18
	#8	0.140	3.56
	#10	0.175	4.45
	#12	0.210	5.33
	#14	0.220	5.59
#4	#12	0.250	6.35
	#14	0.250	6.35
#5	#14	0.500	12.70

1. Total thickness of all steel, including any spacing between layers.
2. Drill and tap capacities may vary.
3. Table is guideline only; see individual product for specific maximum material thickness.

Steel Thickness

Gauge	Mils	Design Thickness		Minimum Thickness	
		(in)	(mm)	(in)	(mm)
25	18	0.0188	0.48	0.0179	0.45
22	27	0.0283	0.72	0.0269	0.68
20 (drywall)	30	0.0312	0.79	0.0296	0.75
20 (structural)	33	0.0346	0.88	0.0329	0.84
18	43	0.0451	1.14	0.0428	1.09
16	54	0.0566	1.44	0.0538	1.37
14	68	0.0713	1.81	0.0677	1.72
12	97	0.1017	2.58	0.0966	2.45

1. One "mil" is 1/1000 (0.001) of an inch. Mil thickness measures the uncoated base material.

Self-Drilling Screw Troubleshooting Guide

Failure Mode	Likely Cause(s)	Suggested Action
Split at point (web) 	Excessive force (feed) applied while drilling	Reduce application force
Outer corners worn or melted 	Drill RPM (cutting speed) too high	Use slower motor or partial trigger pull
Cutting edges chipping or breaking 	Excessive force (feed) applied while drilling	Reduce application force
Point melted or diameter significantly reduced 	Work material too hard Insufficient chip clearance Excessive force (feed) applied while drilling	Confirm work material specs Choose screw with longer pilot section Reduce application force
Screw won't start a hole 	Drill motor set on reverse Work material too hard Drill point blunted by handling	Check motor direction Confirm work material specs

Custom-Order Nails

We Make Nails To Your Specification

Simpson Strong-Tie is proud to be one of the last remaining manufacturers of stainless-steel and copper-alloy nails in the United States. While we specialize in AISI-Type 316 and 304 stainless steel, aluminum, brass, commercial bronze, copper and silicon bronze, exotic alloys pose no problem — provided their mechanical properties are within our manufacturing capabilities. Call Simpson Strong-Tie for details. It may also be helpful to visit www.strongtie.com to download worksheet T-NAIL-WS11 which spells out the needed information.



See page 134 for custom-order nail worksheet

Custom Color Matching

Simpson Strong-Tie offers fasteners in a variety of stock colors to match popular construction materials such as cedar and redwood lumber, major brands of composite decking and siding/trim material. Custom color matching is also available to match virtually any material. Material samples or a Pantone® color number are required and 3-4 week lead times are standard. Call Simpson Strong-Tie for details.

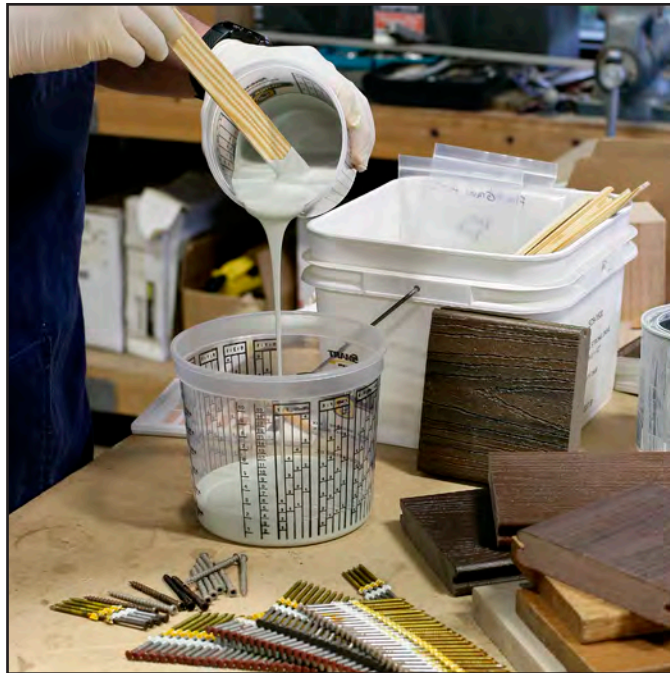

Strong-Drive[®]

STRUCTURAL FASTENERS

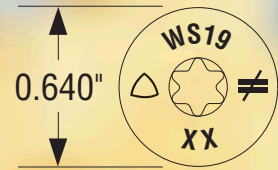

When Performance Is Critical

Best-in-class, load-tested fasteners: Strong-Drive[®] structural fasteners are engineered and extensively tested to efficiently meet your most demanding wood and metal applications. Stronger can also be faster. The Strong-Drive family is designed to install easier than other fastening methods, which saves time and money.

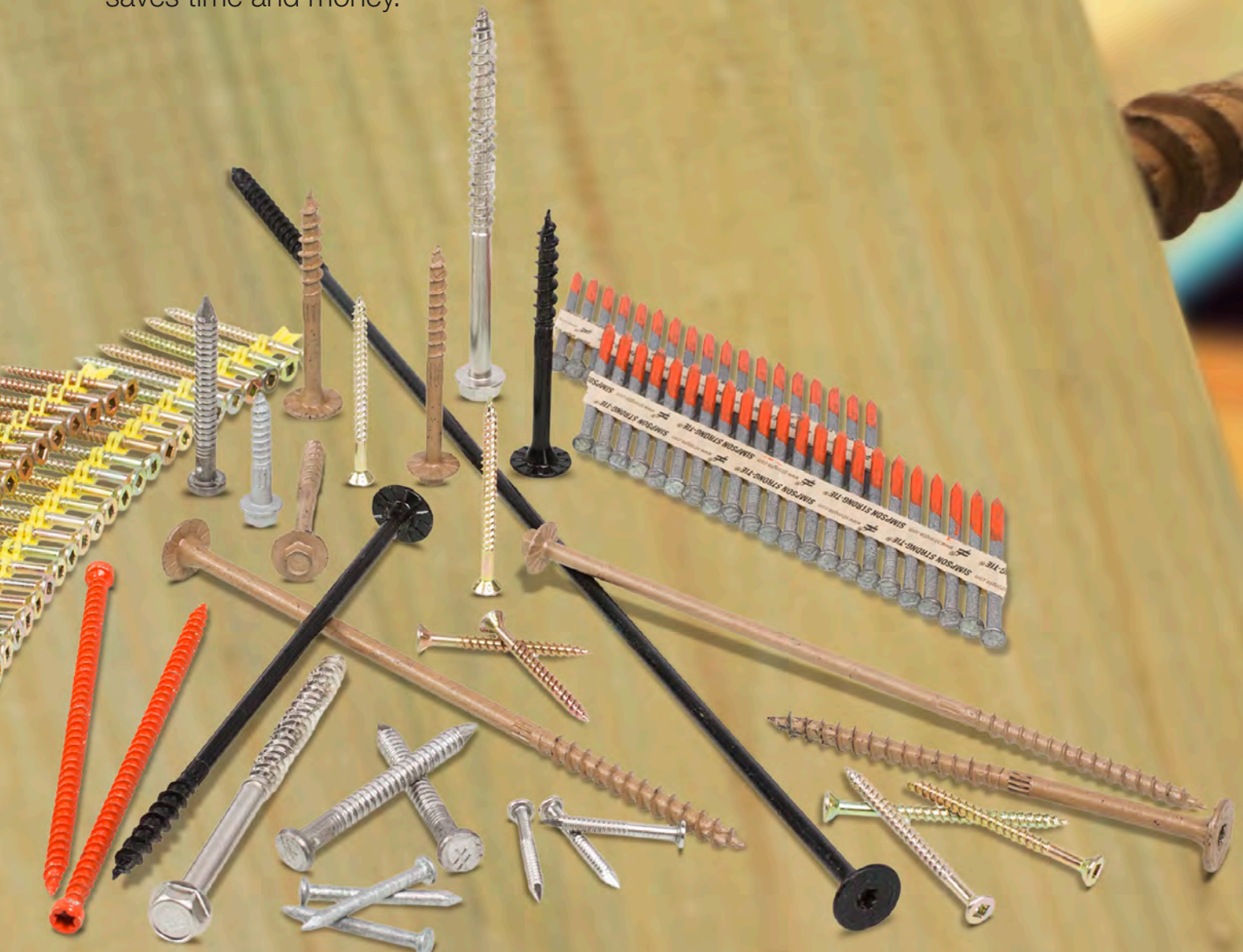

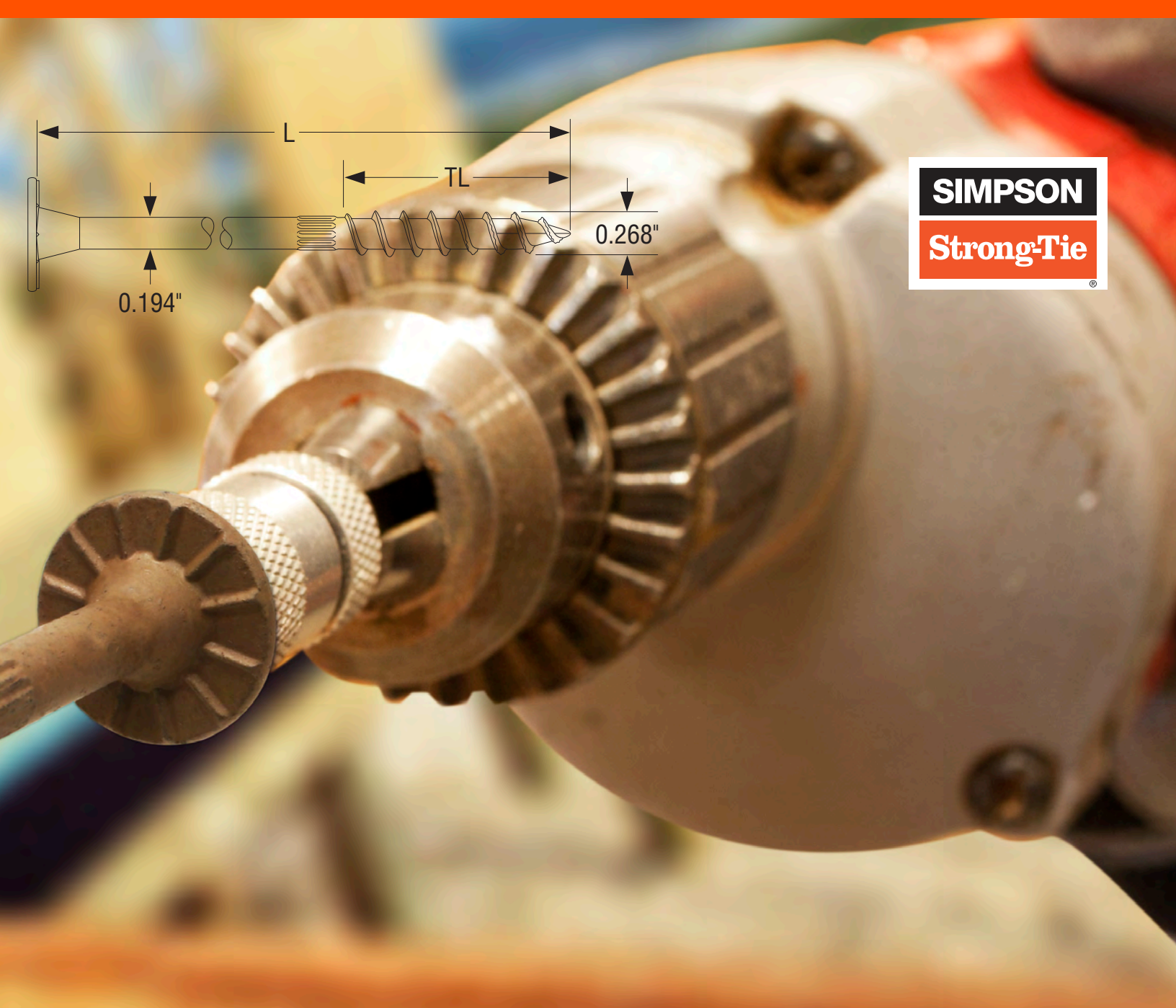
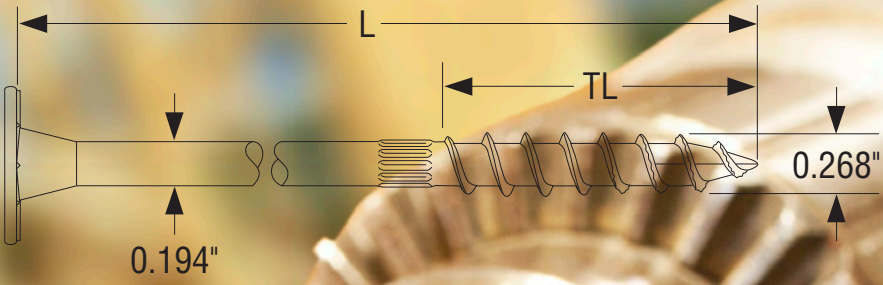

Structural Wood Screws



Structural Metal Screws



Structural Nails



Deck-Drive™

PREMIUM FASTENERS

The Ultimate Deck Screws

Superior performance for decking projects: Deck-Drive™ screws are designed with the most demanding deck builders in mind. Whether the project calls for wood decking, premium composite or exotic hardwoods, you can trust Deck-Drive screws to provide you peace of mind, protect your reputation and keep your customers smiling.

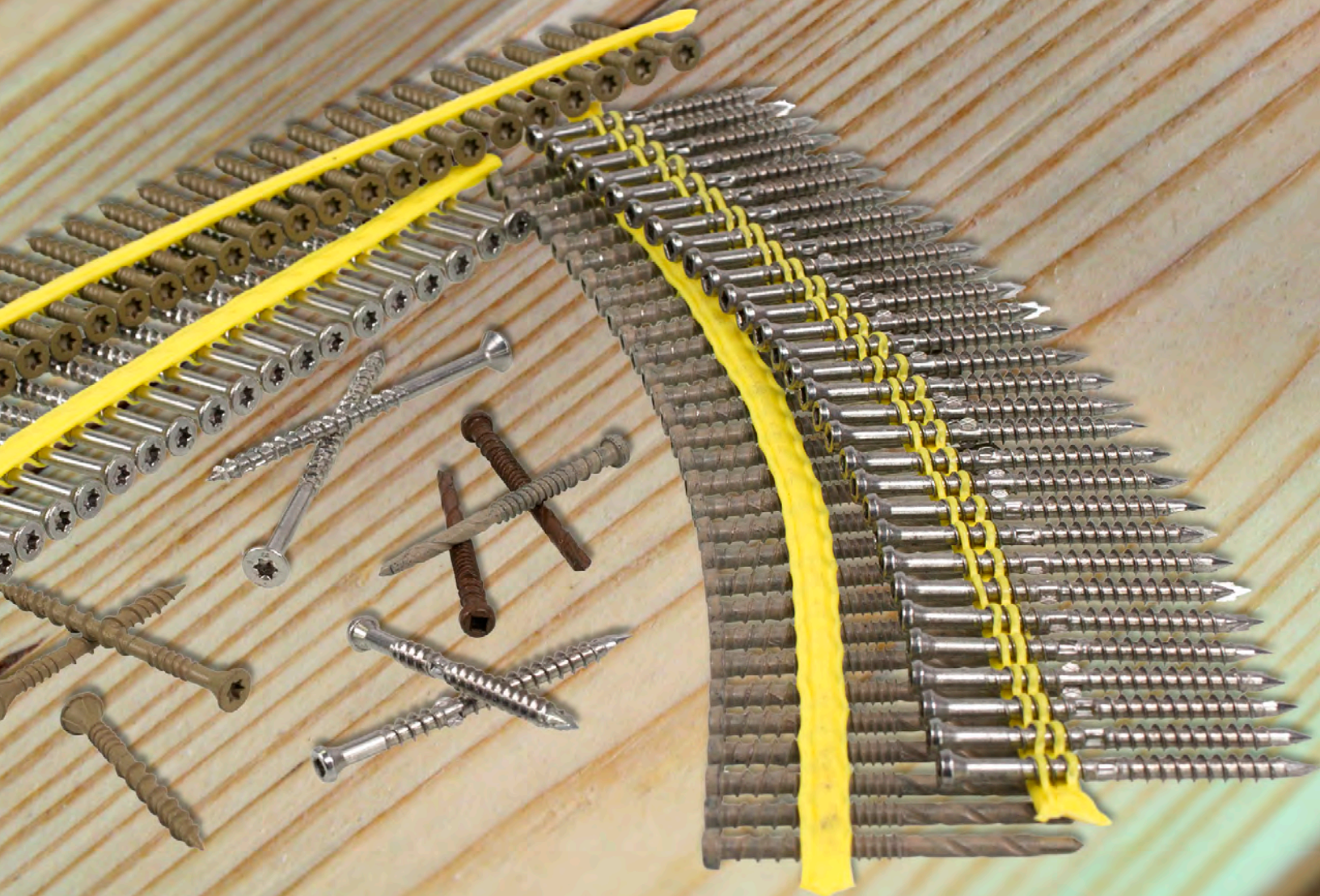



Hardwood Decking



Composite Decking



Wood Decking



Quik Drive®

AUTO-FEED SCREW DRIVING SYSTEMS



Time Saving By Design

Doing the job right doesn't have to take more time: Quik Drive® is the fastest auto-feed screw driving system on the market, ensuring you'll save maximum time during repetitive fastening applications. Rather than installing individual screws, or other more complicated fastening options, Quik Drive operators can work faster, in most cases from an ergonomic standing position. When time is money, Quik Drive is the faster fastener tool.



PRO250 Subfloor System

PRO300S Decking System

PROSD150 Steel-Decking System

SIMPSON
Strong-Tie

QUICK DRIVE

Subfloor

Drywall



Wood Decking



Steel Decking



Stainless-Steel

FASTENERS



Unmatched Quality

Huge selection of stainless-steel screws, nails and staples: When working in harsh environments, building professionals count on Simpson Strong-Tie for one of the largest selection of Type 316 stainless-steel fasteners on the market. Our unmatched selection of Type 316 stainless-steel products, including many Strong-Drive® and Deck-Drive™ fasteners, offers the highest level of corrosion resistance. When you need stainless, Simpson Strong-Tie is your convenient, one-stop source for fasteners that stand the test of time and the elements.



Deck Screws



Marine Screws



Fastener Application Guide



Decks, Docks and Boardwalks



Screws, Nails and Specialty

Strong-Drive®
SDWS **TIMBER** Screw



Washer head, double-barrier coating,
page 58

Strong-Drive®
SDWH **TIMBER-HEX** Screw

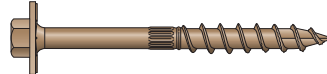

Structural Wood Screw, hex-washer head,
double-barrier coating, page 59

Strong-Drive®
SDWH **TIMBER-HEX SS** Screw

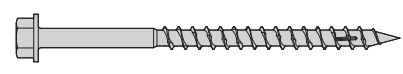

Hex head, Type 316 stainless steel, page 60

Deck-Drive™ DSV **WOOD** Screw



Quik Guard® Coated,
page 63

Deck-Drive™ DWP **WOOD SS** Screw

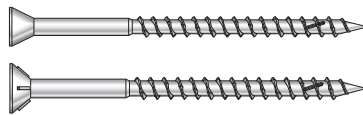

Flat and trim head styles, Types 316 and 305
stainless steel, page 64 Painted head,
Types 316 and 305 stainless steel, page 65

Deck-Drive™ DHPD **HARDWOOD** Screw



Type 305 stainless steel, page 66

Dexxter™
Composite-Decking Screw

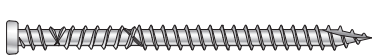

Quik Guard® Coated and Types 316 and 305
stainless steel, page 74, Painted head,
Type 305 stainless steel, page 75

Composi-Lok™
Composite-Decking Screw



Quik Guard® Coated and Type 305
stainless steel, page 76

Trim-Head Decking Screw

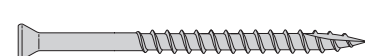

Types 316 and 305 stainless steel, pages
71, 73, Painted head, Types 316 and 305
stainless steel, pages 70, 72

Bugle-Head Wood Decking Screw



Types 316 and 305 stainless steel,
pages 67-69, Painted head, Type 305
stainless steel, page 68

Cedar Redwood
Decking



Types 316 and 304 stainless steel, page 83
Hot-Dip Galvanized, page 83

Preservative-Treated
Wood Decking

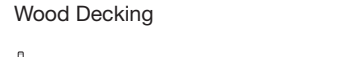

Types 316 and 304 stainless steel, page 91
Hot-Dip Galvanized, page 91

EB-TY® Hidden Deck Fastening System



Page 120

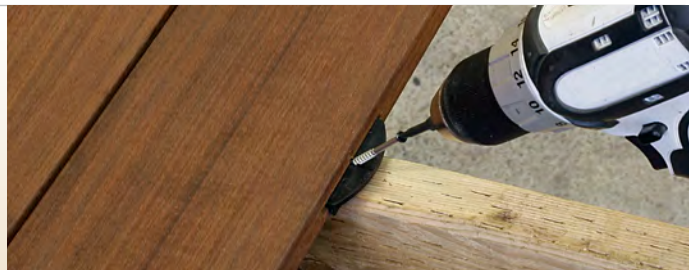

Decks, Docks and Boardwalks (cont.)

Collated Nails

20-22° Plastic Strip, Full Round Head, Ring-Shank Nail



Types 316 and 304 stainless steel and silicon bronze, page 146

20-22° Plastic Strip, Full Round Head, Screw-Shank Nail

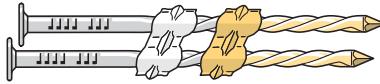

Types 316 and 304 stainless steel, page 147

20-22° Plastic Strip, Casing Head, Ring-Shank Nail



Types 304 stainless steel, page 145

31-34° Plastic Strip, Full Round Head, Ring-Shank Nail



Types 316 and 304 stainless steel and silicon bronze, page 149

31-34° Paper Tape, Clipped Head, Ring-Shank Nail



Types 316 and 304 stainless steel, page 151

28° Wire Weld, Clipped Head, Ring-Shank Nail



Types 304 stainless steel, page 150

15° Wire Coil, Full Round Head, Ring-Shank Nail

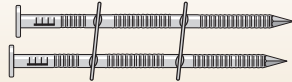

Types 316 and 304 stainless steel, page 143

Collated Screws for the *Quik Drive*® System

Deck-Drive™ DSV **WOOD** Screw



Quik Guard® coating, page 174

Deck-Drive™ DWP **WOOD SS** Screw



Flat head style, Types 316 and 305 stainless steel, page 174

Deck-Drive™ DHPD **HARDWOOD** Screw



Type 305 stainless steel, #10 compact head, page 175

Deck-Drive™ DCSD **COMPOSITE-TO-STEEL** Screw



Quik Guard® coated, page 187

Composi-Lok™ Composite-Decking Screw



Types 316 and 305 stainless steel, Quik Guard® coated, page 186

Trim-Head Decking Screw: Type-17 Point



Trim head, Quik Guard® coating, page 176

Trim-Head Decking Screw: Sharp Point



Types 316 and 305 stainless steel, page 176

SS3DSC Bugle-Head Wood Decking Screw



Types 316 and 305 stainless steel, #10 bugle head, page 177

Strong-Drive® WSNL **WOOD** Screw



Quik Guard® and class 55 galvanized coating, page 175

Subfloor and Sheathing Applications



Collated Screws for the *Quik Drive*® System

Strong-Drive®
WSNTL **SUBFLOOR** Screw



Wood-to-wood applications, yellow-zinc coating, twin thread, pages 188-189

Strong-Drive®
WSNTL **SUBFLOOR** Screw with Type-17



Wood-to-wood applications, yellow-zinc coating, type-17 point, page 188-189

WSHL
Subfloor Screw



Wood-to-wood applications, gray-phosphate coating, high-low threads, page 190

Strong-Drive®
PPSD **SHEATHING-TO-CFS** Screw



Wood-to-steel applications, #2 drill point, Quik Guard® yellow-zinc coating, page 196

WSC
Wood Screw

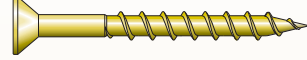

Wood-to-wood applications, yellow-zinc coating, coarse thread, page 193

CBSDQ
Sheathing-to-CDF Screw



Sheathing to cold-formed steel, QuikGuard® coating, page 199

Underlayment and Backerboard Applications



Collated Screws for the *Quik Drive*® System

CB3BLG
Fiber-Cement Board Screw

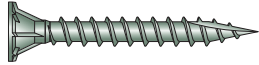

Cement board, C-3 mechanically-galvanized coating, meets ANSI standards, page 177

CB3BLGHL
Cement-Board Screw

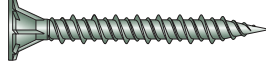

Fiber-cement board, C-3 mechanically-galvanized coating, page 178

MTH
Wood Underlayment Screw



Wood underlayment, gray-phosphate or yellow-zinc coating, page 191

DWF
Drywall-to-CFS Screw



Gypsum panel to steel, gray-phosphate coating, page 200

DWFS
Drywall-to-CFS Screw

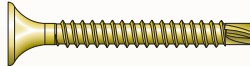

Gypsum panel to steel, yellow-zinc or N2000 galvanized coating, page 200

DWC
Drywall Screw



Gypsum panel to wood, gray-phosphate, yellow-zinc or N2000 galvanized coating, page 190

Siding on Wood and Steel



Screws and Nails

Metal-Panel Screw

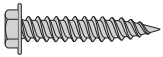

Washer head, Type 316 stainless steel, page 110

Metal-Panel Screw with EPDM Washer



Type 316 stainless steel, page 110

Wire-Lathe Modified Truss-Head Screw



Type 305 stainless steel, page 115

Fiber-Cement Screw

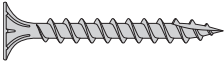

Type 316 stainless steel, page 109

Self-Drilling Fiber-Cement Screw

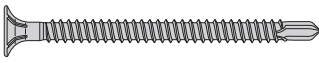

Type 410 stainless steel, page 128

Self-Drilling Siding Screw

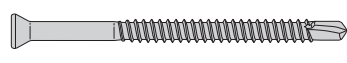

Type 410 stainless steel, page 130

Self-Drilling Wire-Lath Modified Truss-Head Screw

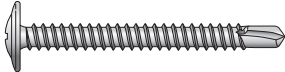

Type 410 stainless steel, page 132

Wood Siding Nail



Types 316 and 304 stainless steel, page 84

Shake and Shingle Siding/Roofing Nail



Types 316 and 304 stainless steel, page 95

Painted Siding Nail



Types 316 and 304 stainless steel, pages 93-94

Fiber-Cement Siding Nail



Type 316 stainless steel, page 87

Pyramid-Head Nail



Type 316 stainless steel and silicone bronze, page 92

Nail with EPDM Washer



Types 316 and 304 stainless steel, page 89

Siding on Wood and Steel (cont.)

Collated Nails and Staples

15° Wire Coil, Full Round Head, Ring-Shank Nail

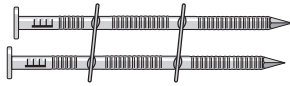

Types 316 and 304 stainless steel, page 139

15° Wire Coil, Painted, Full Round Head, Ring-Shank Nail

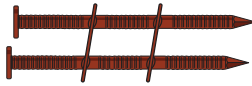

Type 304 stainless steel, page 140

0° and 15° Inserted Plastic Coil, Full Round Checkered Head, Ring-Shank Nail



Types 316 and 304 stainless steel, aluminum, page 136-138

7/16" Crown, 16 Gauge Staple

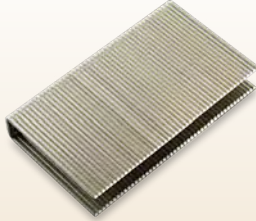

Types 316 and 304 stainless steel, page 163

1/2" Crown, 16 Gauge Staple

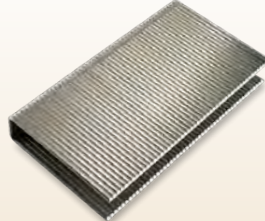

Types 316 and 304 stainless steel, page 161

Collated Screws for the *QuikDrive*® System

CBSDQ
Sheathing-to-CFS Screw



#2 drill point, Quik Guard® coating, page 199

CB3BLG
Fiber-Cement Board Screw

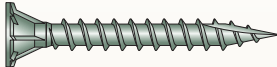

C-3 galvanized coating, page 177

CB3BLGHL
Cement-Board Screw



C-3 galvanized coating, page 178

Roofing



Screws and Nails

Shake and Shingle Siding/Roofing Nail



Types 316 and 304 stainless steel, page 95

Roofing, Tile and Slating Nail



Types 316 and 304 stainless steel, copper and aluminum, pages 100-101

Washed Roofing Nail



Type 304 stainless steel, page 96

Nail with EPDM Washer



Types 316 and 304 stainless steel, page 89

Metal-Panel Screw

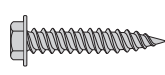

Washer head, Type 316 stainless steel, page 110

Metal-Panel Screw with EPDM Washer



Type 316 stainless steel, page 110

Self-Drilling Truss-Head Screw

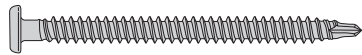

Type 410 stainless steel, page 131

Pancake-Head Screw

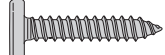

Type 410 stainless steel, page 113

Self-Drilling Pancake-Head Screw

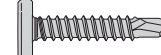

Type 410 stainless steel, page 126

PCULP Collated Standing-Seam-Roofing Panel Clip Screw



Type 410 stainless steel, page 114

Self-Drilling X Metal Screw



5/16" hex head, Quik Guard® and clear-zinc coating, page 125

Roofing (cont.)

Collated Nails and Staples

15° Wire Coil, Full Round Head, Smooth-Shank Roofing Nail

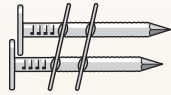

Types 316 and 304 stainless steel, page 142

15° Wire Coil, Full Round Head, Ring-Shank Roofing Nail

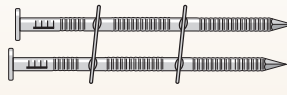

Types 316 and 304 stainless steel, page 141

7/16" Crown, 16 Gauge Staple

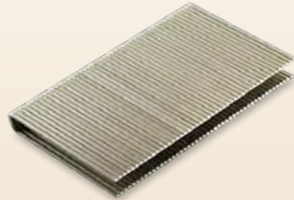

Types 316 and 304 stainless steel, page 163

1/2" Crown, 16 Gauge Staple

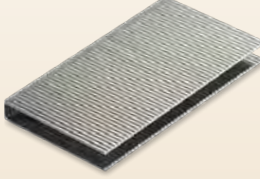

Type 316 stainless steel, page 161

Collated Screws for the *QuikDrive*® System

PCSD Standing-Seam-Roofing Panel Clip Screw

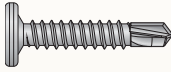

#3 drill point, clear-zinc or Quik Guard® coating and Type 410 stainless steel, page 198

PCULP Standing-Seam-Roofing Panel Clip Screw



Type-17 point, clear-zinc or Quik Guard coating and Type 410 stainless steel, page 192

PC Standing-Seam-Roofing Panel Clip Screw

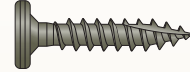

Type-17 point, clear-zinc or Quik Guard® coating and Type 410 stainless steel, page 192

HJ Metal Roofing/Siding Panel Screw



Type 305 stainless steel, page 180

HG Metal Roofing/Siding Panel Screw

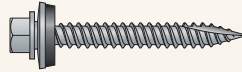

Class 55 galvanized coating, Type-17 point, page 180

WSCD Roofing Tile Screw



Miami-Dade compliant, meets ASTM B695 class 55 mechanically galvanized coating, page 185

WSCT Roofing Tile Screw



Meets ASTM A641 class 1 standard, Heavy-Zinc Electroplate coating, page 185

SSWSCB Roofing Tile Screw



Type-17 point, Type 305 stainless steel, page 184

Wood Framing



Screws

Strong-Drive®
SDWS **TIMBER** Screw



Washer head, double-barrier coating, page 58

Strong-Drive®
SDWH **TIMBER-HEX** Screw

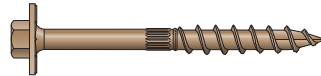

Washer head, double-barrier coating, page 59

Strong-Drive®
SDWH **TIMBER-HEX SS** Screw

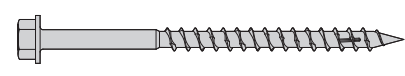

Type 316 Stainless Steel, page 60

Strong-Drive®
SDW **TRUSS-PLY** Screw



Washer head, E-Coat™ coating, page 79

Strong-Drive®
SDW **EWP-PLY** Screw



Washer head, E-Coat™ coating, page 78

Strong-Drive®
SDWC **TRUSS** Screw

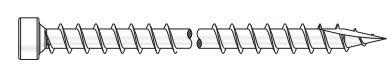

Clear-Zinc coating (with orange topcoat), page 77

Strong-Drive®
SDWS **LOG** Screw



Washer head, E-Coat™ coating, page 79

Strong-Drive®
SWDF **FLOOR-TO-FLOOR** Screw

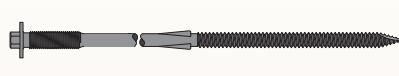

E-Coat™ coating, page 80

Strong-Drive®
SDS **HEAVY-DUTY CONNECTOR** Screw

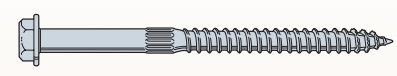

Type 316 Stainless Steel and Double-Barrier Coating, page 61

Strong-Drive®
SD **CONNECTOR** Screw

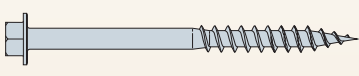

Class 55 mechanically galvanized, page 62

Wood Framing (cont.)

Nails

Strong-Drive® SCN

SMOOTH-SHANK CONNECTOR Nail



Bright, Hot-dip galvanization, page 103

Strong-Drive® SCNR

RING-SHANK CONNECTOR Nail



Type 316 stainless steel, hot-dip galvanized, bright, page 102

Common Nail, Ring-Shank



Types 316 and 304 stainless steel, page 85

Common Nail, Smooth-Shank

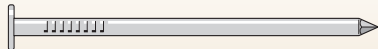

Types 316 and 304 stainless steel, Hot dip galvanized, page 86

Post and Beam Nail, Ring-Shank



Types 316 and 304 stainless steel, page 90

Box Nail, Ring-Shank



Types 316 and 304 stainless steel, page 82

Collated Nails

20-22° Plastic Strip

Full Round Head, Ring-Shank Nail



Types 316 and 304 stainless steel, page 146

20-22° Plastic Strip

Full Round Head, Screw-Shank Nail

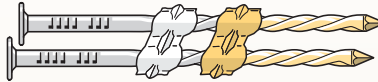

Types 316 and 304 stainless steel, page 147

20-22° Plastic Strip

Casing Head, Ring-Shank Nail



Type 304 stainless steel, page 145

20-22° Plastic Strip

Full Round Head, Smooth-Shank Nail

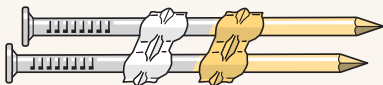

Types 316 and 304 stainless steel, page 148

28° Wire Weld

Clipped Head, Ring-Shank Nail



Type 304 stainless steel, page 150

31-34° Plastic Strip

Full Round Head, Ring-Shank Nail

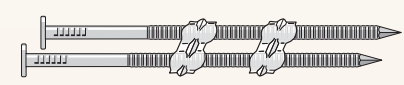

Types 316 and 304 stainless steel, page 149

31-34° Paper Tape

Clipped Head, Ring-Shank Nail

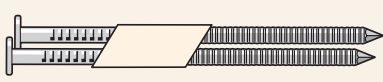

Types 316 and 304 stainless steel, page 151

15° Wire Coil, Full Round

Head, Ring-Shank Nail

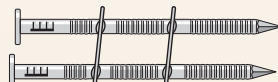

Types 316 and 304 stainless steel, page 143

Fasteners for Simpson Strong-Tie® Connectors



Screws and Nails

Strong-Drive®
SD **CONNECTOR** Screw

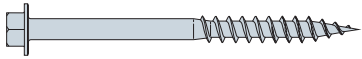

Class 55 mechanically galvanized, page 62

Strong-Drive®
SDS **HEAVY-DUTY CONNECTOR** Screw

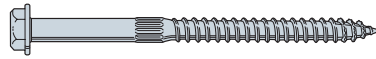

Double-barrier coating, Type 316 stainless steel, page 61

Wafer-Head Screw

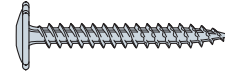

Clear zinc coating, page 80

Strong-Drive® XE **EXTERIOR STRUCTURAL METAL** Screw

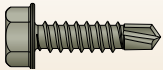

Quik Guard® coating, page 122

Strong-Drive® SCNR **RING-SHANK CONNECTOR** Nail



Type 316 stainless steel, hot-dip galvanized, bright, page 102

Strong-Drive®
SCN **SMOOTH-SHANK CONNECTOR** Nail

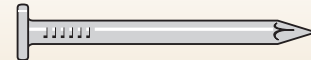

Hot-dip galvanized, bright, page 103

Collated Nails

Strong-Drive®
33° SCNR **COLLATED RING-SHANK CONNECTOR** Nail

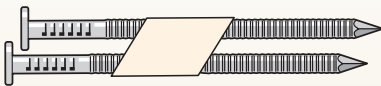

Type 316 stainless steel, page 152

Strong-Drive®
33° SCN **SMOOTH-SHANK COLLATED CONNECTOR** Nail

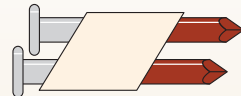

Hot-dip galvanized, page 152

Finishing, Millwork and Trim



Screws and Nails

Deck-Drive™ DWP **WOOD SS** Screw



Trim-head, Types 305 and 316 stainless steel, page 64

Trim-Head Wood Decking Screw

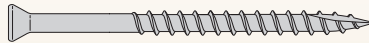

Types 316 and 305 stainless steel, pages 70-73, Painted head, Types 316 and 305 stainless steel, pages 70, 72

Finishing Nail



Types 316 and 304 stainless steel, page 88

Pocket Hole Screw

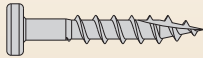

Type 305 stainless steel, page 117

Collated Nails

20° Adhesive Collation
T-Style Head Angle Finishing Nail

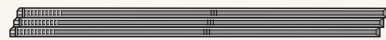

16 gauge, Types 316 and 304 stainless steel, page 153

33° Tape Collation
DA-Style Head Angle Finishing Nail



15 gauge, Types 316 and 304 stainless steel, page 158

25° Adhesive Collation
FN-Style Head Angle Finishing Nail



15 gauge, Types 316 and 304 stainless steel, page 154

16-Gauge Straight Adhesive
Collation T-Style Head Finishing Nail



Types 316 and 304 stainless steel, page 155

18-Gauge Straight Adhesive
Collation T-Style Head Brads



Types 316 and 304 stainless steel, page 156

Adhesive Collation Straight
Headless Micro Pins



23 gauge, Type 304 stainless steel, page 157

Collated Staples

¼" Crown, 18 Gauge Staple



Types 316 and 304 stainless steel, page 162

⅜" Crown, 22 Gauge Staple



Type 304 stainless steel, page 164

Fastening to Metal

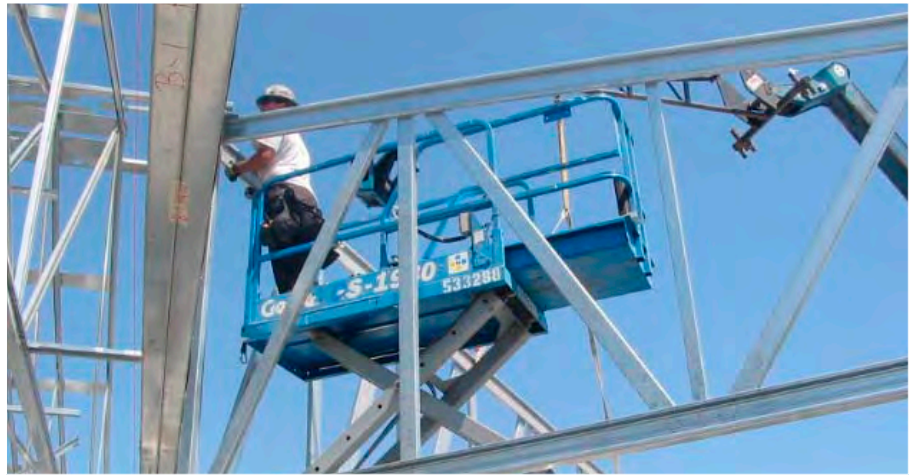

Screws

Strong-Drive® XE **EXTERIOR STRUCTURAL METAL** Screw

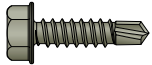

Quik Guard® Coating, page 122

Strong-Drive® FPHSD **FRAMING-TO-CFS** Screw

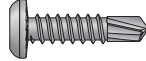

Clear zinc coating, page 124

Strong-Drive® PPSD **SHEATHING-TO-CFS** Screw



Subfloor to CFS Screw Quik Guard® and yellow zinc coating, page 123

Self-Drilling X Metal Screw



5/16" hex head, Quik Guard® and clear-zinc coating, page 125

PCSD Collated Standing-Seam Roofing Panel Clip Screw

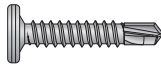

Type 410 stainless steel, Quik Guard® and clear zinc coating, page 126

Self-Drilling Fiber-Cement Screw

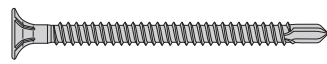

Type 410 stainless steel, page 128

Self-Drilling Siding Screw

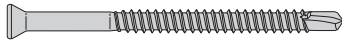

Type 410 stainless steel, page 130

Self-Drilling Wire-Lath Modified Truss-Head Screw

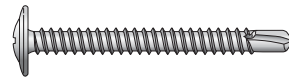

Type 410 stainless steel, page 132

Self-Drilling Truss-Head Screw

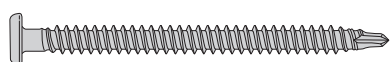

Type 410 stainless steel, page 131

Self-Drilling Bugle-Head Screw

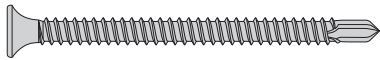

Type 410 stainless steel, page 127

Self-Drilling Flat-Head Screw with Wings



Type 410 stainless steel, page 129

Self-Drilling Wafer-Head Screw with Wings

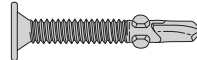

Type 410 stainless steel, page 131

Pancake-Head Screw

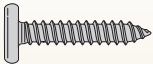

Type 410 stainless steel, Quik Guard® and clear-zinc coating, page 113

Fastening to Metal (cont.)

Collated Screws for the *QuikDrive*® System

Strong-Drive®
TB **WOOD-TO-STEEL** Screw



#4 drill point, black-phosphate coating,
page 194

Strong-Drive®
TB **WOOD-TO-STEEL** Screw



#4 drill point, yellow-zinc coating,
page 194

Strong-Drive®
TB **WOOD-TO-STEEL** Screw



#4 drill point, mechanically galvanized,
page 194

Strong-Drive®
PPSD **SHEATHING-TO-CFS** Screw



#3 drill point, Quik Guard®, yellow-zinc coating,
page 196

FHSD
Wood-to-CFS Screw

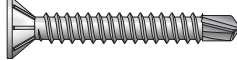

#2 drill point, Type 410 stainless steel,
page 201

DWFSD
Drywall-to-CFS Screw



Drywall to steel, #2 point, yellow-zinc
and N2000 galvanized coatings available
(54, 43 mils / 16, 18 ga), page 200

DWFSD Drywall-to-CFS Screw

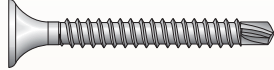

Drywall to steel, #2 point, N2000 galvanized
coating (54, 43 mils / 16, 18 ga), page 200

Self-Drilling X Metal Screw



5/16" hex head, Quik Guard®
and clear-zinc coating, page 197

CBSDQ Sheathing-to-CFS Screw



Sheathing-to-steel, #2 drill point, Quik Guard®
coating, page 199

Fencing



Screws and Nails

Strong-Drive®
SDWS **TIMBER** Screw



Double-barrier coating, page 58

Strong-Drive®
SDWH **TIMBER-HEX** Screw



Double-barrier coating, page 59

Strong-Drive®
SDWH **TIMBER-HEX SS** Screw

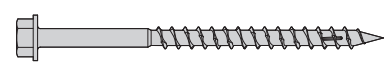

Type 316 stainless steel, page 60

Strong-Drive®
SDS **HEAVY-DUTY CONNECTOR** Screw



Double-barrier coating, Type 316 stainless steel, page 61

Deck-Drive™
DSV **WOOD** Screw



Quik Guard® coating, page 63

Deck-Drive™
DWP **WOOD SS** Screw

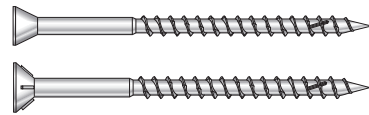

Flat and Trim head styles, Types 316 and 305 stainless steel, page 64. Painted head, Types 316 and 305 stainless steel, page 65

Trim-Head Wood Decking Screw



Types 316 and 305 stainless steel, pages 70-73, Painted head, Types 316 and 305 stainless steel, pages 70, 72

Bugle-Head Wood Decking Screw



Types 316 and 305 stainless steel, pages 67-69, Painted head, Type 305 stainless steel, page 68

Fencing Nail



Types 316 and 304 stainless steel, page 87

Fencing (cont.)

Collated Nails

20-22° Plastic Strip, Full Round Head, Ring-Shank Nail



Types 316 and 304 stainless steel, page 146

28° Wire Weld, Clipped Head, Ring-Shank Nail



Type 304 stainless steel, page 150

31-34° Paper Tape, Clipped Head, Ring-Shank Nail



Types 316 and 304 stainless steel, page 151

15° Wire Coil, Full Round Head, Ring-Shank Nail

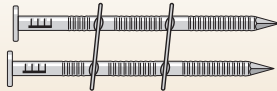

Types 316 and 304 stainless steel, page 141

0° and 15° Inserted Plastic Coil, Full Round Checkered Head, Ring-Shank Nail



Types 316 and 304 stainless steel, pages 136-138

Collated Screws for the *QuikDrive*® System

Deck-Drive™ DSV **WOOD** Screw



Quik Guard® coating, page 174

Deck-Drive™ DWP **WOOD SS** Screw

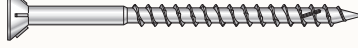

Flat head style, Types 316 and 305 stainless steel, page 174

WSC Wood Screw



N2000® Coating, page 184

Cooling Towers



Nails

Common Nail – Annular Ring-Shank



Types 316 and 304 stainless steel, page 85

Common Nail Spiral-Shank (Special-Order Option)



Types 316 and 304 stainless steel, page 85

Box Nail – Annular Ring-Shank



Types 316 and 304 stainless steel, page 82

Box Nail, Spiral-Shank Nail (Special-Order Option)



Types 316 and 304 stainless steel, special order option, page 82

Roofing Tile and Slating Nail



Types 305 stainless steel, copper and aluminum, pages 100-101

Nail with EPDM Washer – Annular Ring-Shank



Type 304 stainless steel, page 89

Screws

Bugle-Head Wood Decking Screw



Types 316 and 304 stainless steel, pages 67-69

Trim-Head Screw with EPDM Sealing Washer

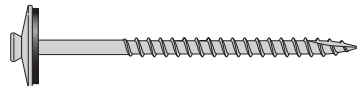

Type 305 stainless steel, copper and aluminum, page 115

Self-Drilling Hex-Washer Head Screw

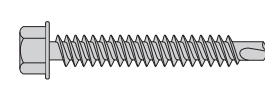

Types 316 and 305 stainless steel, page 111

Self-Drilling Hex-Washer Head Screw with EPDM Sealing Washer

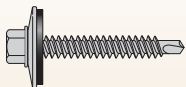

Types 316 and 304 stainless steel, page 112

Cooling Towers (cont.)

Specialty

Fencing Staples

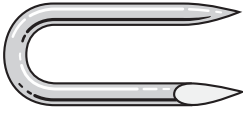

Type 304 stainless steel, page 105

Hog Ring – Blair Shaped



Type 304 stainless steel, page 105

Hog Ring – #3 Pre-Bent, Hill Pattern



Type 304 stainless steel, page 105

Sealing Washer



Types 316 and 304 stainless steel,
page 119

Log Homes



Screws

Strong-Drive® SDWS **LOG** Screw

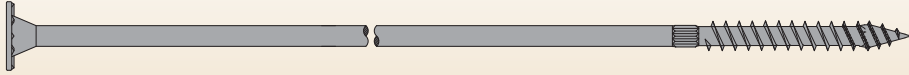

E-coat, page 79

Steel Decking

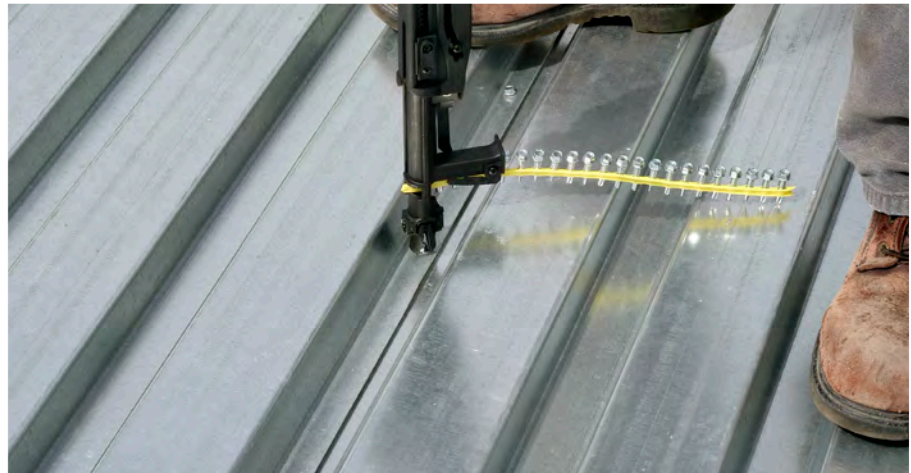

Screws

Self-Drilling X Metal Screw



5/16" hex head, Quik Guard® and clear-zinc coating, page 125

Collated Screws for *Quik Drive*® Systems

Self-Drilling X Metal Screw



5/16" hex head, Quik Guard® and clear-zinc coating, page 197

Truss-Ply Fastening Applications



Screws and Collated Screws for the *Quik Drive*® System

Strong-Drive® SDW **TRUSS-PLY** Screw



Screw-Multi-Ply Fastening
Washer head E-Coat™ coating, page 79

Strong-Drive® WSNTL **WOOD** Screw



Twin thread, yellow zinc coating, pages 188-189

Drywall and Exterior Gypsum Sheathing Applications



Collated Screws for the *Quik Drive*® System

DWC Drywall Screw



Drywall to wood, gray-phosphate, N2000® and yellow-zinc coatings available, page 190

DWF Drywall-to-CFS Screw



Drywall to steel, gray-phosphate coating (33, 27, 18 mils / 20, 22, 25 ga), page 200

DWFSD Drywall Screw



Drywall to steel, #2 point, yellow-zinc coatings available (54, 43 mils / 16, 18 ga), page 200

DWHL Drywall Screw



High-low threads, gray-phosphate coating, page 191

Crating



Screws

Crate Screw



Black E-coat™, page 103

Strong-Drive® SDWS **TIMBER** Screw



Double-barrier Coating, page 58

Wafer-Head Screw

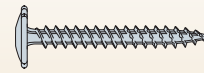

Clear zinc coating, page 80

Collated Screws for the *Quik Drive*® System

Strong-Drive®
WSNTL **SUBFLOOR** Screw



Wood-to-wood applications, yellow-zinc coating, twin thread, pages 188-189

Strong-Drive® WSNTL **SUBFLOOR** Screw with Type-17



Wood-to-wood applications, yellow-zinc coating, type-17 point, page 188-189

DWC Drywall Screw



Quik Guard® or class 55 galvanized coating, page 190

PHSS Wood Screw



Yellow zinc coating, page 193

WSHL Subfloor Screw



Gray-phosphate coating, page 190

Boat Building/Marine Trade

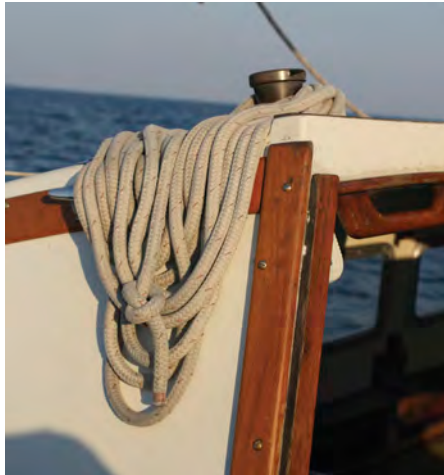

Screws and Nails

Marine Screw – Oval Head

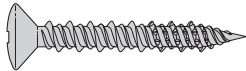

Type 316 stainless steel, page 108

Marine Screw – Flat Head



Type 316 stainless steel, page 107

Marine Screw – Pan Head

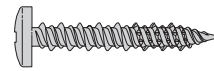

Type 316 stainless steel, page 106

Bugle-Head Wood Decking Screw



Type 316 stainless steel, pages 67-69

Trim-Head Wood Decking Screw

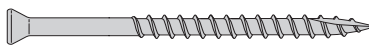

Type 316 stainless steel, pages 70-73

Common Nail – Annular Ring-Shank



Type 316 stainless steel, page 85

Roofing – Annular Ring-Shank



Silicon Bronze available for special order, pages 97-98

Finishing Nail

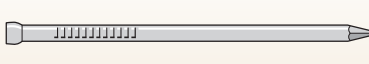

Type 316 stainless steel, page 88

Premium Common Nail



Type 316 stainless steel, passivated page 81

Collated Nails

20-22° Plastic Strip, Full Round Head, Smooth-Shank Nail

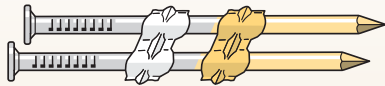

Types 316 and 304 stainless steel, page 148

15° Wire Coil, Full Round Head, Roofing Nail



Types 316 and 304 stainless steel, page 141

15° Wire Coil, Full Round Head, Ring-Shank Nail

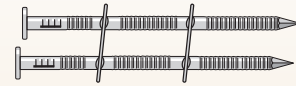

Types 316 and 304 stainless steel, pages 139-140



Quality and Reliability
is our top priority

Screws and Nails



Exterior Wood Screws

Strong-Drive® SDWS TIMBER Screw

Structural Wood-to-Wood Connections Including Ledgers

Designed to provide an easy-to-install, high-strength alternative to through-bolting and traditional lag screws. The SDWS structural wood screws are ideal for the contractor and do-it-yourselfer alike.

Features:

- Bold thread design that provides superior holding power
- Patented 4CUT™ tip that ensures fast starts, reduces installation torque and eliminates the need for pre-drilling in most applications
- Under-head ribs that offer greater control when seating the head
- Large washer head provides maximum bearing area (0.75" head dia.)
- Size identification on all SDWS screw heads

Double-barrier coating provides corrosion resistance equivalent to hot-dip galvanization, making it suitable for certain exterior and preservative-treated wood applications, as described in the evaluation report.

Codes/Standards: IAPMO-UES ER-192, State of Florida FL13975

For Technical Data and Loads, see pages 272-281

U.S. Patents 5,897,280; 7,101,133

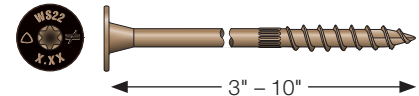

Double-Barrier Coating

Size Dia. x L (in.)	Thread Length (in.)	Retail Clam			Retail Pack			Mini-Bulk		Bulk	
		Fasteners Per Pack	Packs Per Master Carton	Model No.	Fasteners Per Pack	Packs Per Master Carton	Model No.	Fasteners Per Pack	Model No.	Fasteners Per Pack	Model No.
0.220 x 3	1½	12	10	SDWS22300DB-RC12	50	6	SDWS22300DB-R50	250	SDWS22300DBMB	950	SDWS22300DB
0.220 x 4	2¾	12	10	SDWS22400DB-RC12	50	6	SDWS22400DB-R50	250	SDWS22400DBMB	600	SDWS22400DB
0.220 x 5	2¾	12	10	SDWS22500DB-RC12	50	6	SDWS22500DB-R50	250	SDWS22500DBMB	600	SDWS22500DB
0.220 x 6	2¾	12	10	SDWS22600DB-RC12	50	6	SDWS22600DB-R50	250	SDWS22600DBMB	500	SDWS22600DB
0.220 x 8	2¾	12	10	SDWS22800DB-RC12	50	6	SDWS22800DB-R50	250	SDWS22800DBMB	400	SDWS22800DB
0.220 x 10	2¾	12	10	SDWS221000DBRC12	50	6	SDWS221000DB-R50	—	—	250	SDWS221000DB

Retail and mini-bulk packs include one, 6-lobe, T-40 driver bit; bulk packs include two driver bits

- These coated fasteners possess a level of corrosion resistance that makes them suitable for use in some exterior and corrosive environments and with some preservative-treated woods. For applications in higher-exposure applications, consider Type-300 series stainless-steel fasteners for superior corrosion resistance. See page 15 for additional important information before selecting a fastener for a specific application.

Exterior Wood Screws

Strong-Drive® SDWH TIMBER-HEX Screw

Structural Wood-to-Wood Connections Including Ledgers

Ideal for structural and general-purpose fastening applications where a hex-head drive is preferred. The SDWH structural wood screws are ideal for the contractor and do-it-yourselfer alike.

Features:

- Bold thread design that provides superior holding power
- Patented 4CUT™ tip that ensures fast starts, reduces installation torque and eliminates the need for pre-drilling in most applications
- Under-head nibs that offer greater control when seating the head
- Large washer head provides maximum bearing area (0.64" head dia.)
- Size identification on all SDWH screw heads

Double-barrier coating provides corrosion resistance equivalent to hot-dip galvanization, making it suitable for certain exterior and preservative-treated wood applications, as described in the evaluation report.

Codes/Standards: IAPMO-UES ER-192, State of Florida FL13975

For Technical Data and Loads, see pages 283-290

U.S. Patents 5,897,280; 7,101,133

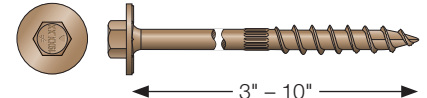

Double-Barrier Coating

Size Dia. x L (in.)	Thread Length (in.)	Retail Clam			Retail Pack			Mini-Bulk		Bulk	
		Fasteners Per Pack	Packs Per Master Carton	Model No.	Fasteners Per Pack	Packs Per Master Carton	Model No.	Fasteners Per Pack	Model No.	Fasteners Per Pack	Model No.
0.195 x 3	1½	12	10	SDWH19300DB-RC12	50	6	SDWH19300DB-R50	250	SDWH19300DBMB	1000	SDWH19300DB
0.195 x 4	2¾	12	10	SDWH19400DB-RC12	50	6	SDWH19400DB-R50	250	SDWH19400DBMB	800	SDWH19400DB
0.195 x 6	2¾	12	10	SDWH19600DB-RC12	50	6	SDWH19600DB-R50	250	SDWH19600DBMB	600	SDWH19600DB
0.195 x 8	2¾	12	10	SDWH19800DB-RC12	50	6	SDWH19800DB-R50	250	SDWH19800DBMB	500	SDWH19800DB
0.195 x 10	2¾	12	10	SDWH191000DBRC12	50	6	SDWH191000DB-R50	—	—	250	SDWH191000DB

Retail and mini-bulk packs include one, 5/16" hex driver bit; bulk packs include two driver bits.

- These coated fasteners possess a level of corrosion resistance that makes them suitable for use in some exterior and corrosive environments and with some preservative-treated woods. For applications in higher-exposure applications, consider Type-300 series stainless-steel fasteners for superior corrosion resistance. See page 15 for additional important information before selecting a fastener for a specific application.

Exterior Wood Screws

Strong-Drive® SDWH TIMBER-HEX SS Screw

Structural Wood-to-Wood Connections Including Ledger

Stainless-steel structural fasteners designed for lag-screw replacement. These 0.188" and 0.276" diameter hex-head fasteners require no pre-drilling, making them easier and faster to install than typical lag screws.

Features:

- Type 316 stainless steel for maximum corrosion protection
- No predrilling necessary in most applications
- Load values exceed those of larger diameter lag screws
- Driver bit included
- Can be used in ledger applications
- Unique "box" thread design with raised-ridge technology significantly reduces driving torque and installation time
- Hex-washer head provides large bearing area

For Technical Data and Loads, see pages 291-293

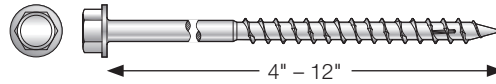

Type 316 Stainless Steel

Size (in.)	Hex Drive (in.)	Thread Length (in.)	Package		Bucket	
			Fasteners Per Pack	Model No.	Fasteners Per Bucket	Model No.
0.188 x 4	5/16	2.40	20	SDWH19400SS-R20	100	SDWH19400SS-R100
0.188 x 4.5	5/16	2.75	10	SDWH19450SS-R10	100	SDWH19450SS-R100
0.188 x 5	5/16	2.40	10	SDWH19500SS-R10	100	SDWH19500SS-R100
0.188 x 6	5/16	2.40	10	SDWH19600SS-R10	100	SDWH19600SS-R100
0.188 x 8	5/16	2.40	10	SDWH19800SS-R10	50	SDWH19800SS-R50
0.276 x 3	1/2	2.95	10	SDWH27300SS-R10	100	SDWH27300SS-R100
0.276 x 4	1/2	2.95	10	SDWH27400SS-R10	100	SDWH27400SS-R100
0.276 x 5	1/2	2.95	10	SDWH27500SS-R10	50	SDWH27500SS-R50
0.276 x 6	1/2	2.95	10	SDWH27600SS-R10	50	SDWH27600SS-R50
0.276 x 8	1/2	2.95	10	SDWH27800SS-R10	25	SDWH27800SS-R25
0.276 x 10	1/2	2.95	5	SDWH271000SS-R5	25	SDWH271000SS-R25
0.276 x 12	1/2	2.95	5	SDWH271200SS-R5	25	SDWH271200SS-R25

Exterior Wood Screws

Strong-Drive® SDS HEAVY-DUTY CONNECTOR Screw

Heavy-Duty Simpson Strong-Tie® Connectors

A 1/4" diameter high-strength structural wood screw ideal for various connector installations as well as wood-to-wood applications.

Features:

- Patented 4-CUT™ point (coated version) and type-17 point (stainless version) enable easy driving with no pre-drilling and minimal splitting
- Available with a double-barrier coating and Type 316 stainless steel
- 3/8" hex head
- Head is stamped with the Simpson Strong-Tie "S" sign and fastener length for easy identification after installation

Install Tips: A low-speed 1/2" drill with a 3/8" hex driver is the recommended tool for installation.

Codes/Standards: ICC-ES ESR-2236; City of L.A. RR25711

For Technical Data and Loads, see pages 317-321

U.S. Patents 6,109,850; 5,897,280; 7,101,133

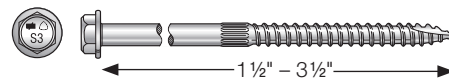

Type 316 Stainless Steel

Size (in.)	Thread Length (in.)	Retail Pack		Bulk	
		Fasteners Per Pack	Model No.	Fasteners Per Pack	Model No.
1/4 x 1 1/2	1	25	SDS25112SS-R25	1500	SDS25112SS
1/4 x 2	1 1/4	25	SDS25200SS-R25	1300	SDS25200SS
1/4 x 2 1/2	1 1/2	25	SDS25212SS-R25	1100	SDS25212SS
1/4 x 3	2	25	SDS25300SS-R25	950	SDS25300SS
1/4 x 3 1/2	2 1/4	25	SDS25312SS-R25	900	SDS25312SS
		25	SDS25312SS-R25L*	—	—

* Packaged in a ledger specific box with 3/8" hex-driver bit.

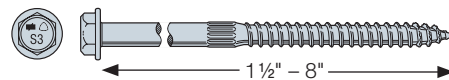

Double-Barrier Coating

Size (in.)	Thread Length (in.)	Retail Pack		Mini Bulk		Bulk	
		Fasteners Per Pack	Model No.	Fasteners Per Pack	Model No.	Fasteners Per Pack	Model No.
1/4 x 1 1/2	1	25	SDS25112-R25	300	SDS25112MB	1500	SDS25112
1/4 x 2	1 1/4	25	SDS25200-R25	250	SDS25200MB	1300	SDS25200
1/4 x 2 1/2	1 1/2	25	SDS25212-R25	200	SDS25212MB	1100	SDS25212
1/4 x 3	2	25	SDS25300-R25	150	SDS25300MB	950	SDS25300
1/4 x 3 1/2	2 1/4	10	SDS25312-R10	125	SDS25312MB	900	SDS25312
		25	SDS25312-R25L*	—	—	—	—
1/4 x 4 1/2	2 3/4	10	SDS25412-R10	100	SDS25412MB	800	SDS25412
1/4 x 5	2 3/4	10	SDS25500-R10	—	—	—	—
		25	SDS25500-R25L*	100	SDS25500MB	500	SDS25500
1/4 x 6	3 1/4	10	SDS25600-R10	100	SDS25600MB	600	SDS25600
1/4 x 8	3 1/4	50	SDS25800-R50	—	—	400	SDS25800
		10	SDS25800-R10	—	—	—	—

* Packaged in a ledger specific box with 3/8" hex-driver bit.

- These coated fasteners possess a level of corrosion resistance that makes them suitable for use in some exterior and corrosive environments and with some preservative-treated woods. For applications in higher-exposure applications, consider Type-300 series stainless-steel fasteners for superior corrosion resistance. See page 15 for additional important information before selecting a fastener for a specific application.

Exterior Wood Screws

Strong-Drive® SD CONNECTOR Screw

Simpson Strong-Tie® Connectors

The Strong-Drive® SD Connector screw is specifically designed to replace nails in certain Simpson Strong-Tie connectors, and is the only screw approved for that application. The load-rated SD screw has been tested and approved for use in many popular Simpson Strong-Tie products. In certain applications screws are easier and more convenient to install than nails, and the single-fastener load values achieved by the SD screw exceed those of typical 10d common or 16d common nails, respectively. In addition, the galvanized coating makes the SD screw ideal for both interior and most exterior conditions.

Features:

- Specifically designed to replace nails in certain Simpson Strong-Tie connectors, and is the only screw approved for that application. The #9 and #10 SD screws replace 10d and 16d nails respectively.
- Tested and approved for use in many of our best-selling connectors for both interior and exterior applications
- Ideal for use in connector applications where more control is desired or using a hammer is inconvenient
- ¼" hex head reduces cam-out and is stamped with the Simpson Strong-Tie "S" sign and the fastener size for easy identification after installation
- Shank is specifically designed to match the fastener holes in Simpson Strong-Tie connectors
- Patented serrated threads and sharp point make driving easy
- Optimized heat treating for ductility and strength
- The single-fastener load capacity of the SD9 exceeds the capacity of a 10d common nail, while the single-fastener load capacity of the SD10 exceeds that of the 16d common nail
- Hex driver included

Mechanically-galvanized coating meets ASTM B695 Class 55, is recommended for use with certain preservative-treated woods and recognized as an alternate to hot-dip galvanized in ESR-3046; it is compliant with the 2006, 2009, and 2012 International Residential Code® (2006 Section R319.3, 2009 Section R317.3.1).

Codes/Standards: ICC-ES ESR-3046

For Technical Data and Loads, see pages 322-323
U.S. Patent 7,101,133

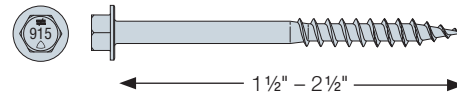

Mechanically-Galvanized Coating – Class 55

Size	Length (in.)	Retail Pack			Contractor Pack			Mini Bulk	
		Fasteners Per Pack	Packs Per Master Carton	Model No.	Fasteners Per Pack	Packs Per Master Carton	Model No.	Fasteners Per Pack	Model No.
#9	1½	100	10	SD9112R100	500	3	SD9112R500	3000	SD9112MB
#9	2½	100	6	SD9212R100	500	2	SD9212R500	2000	SD9212MB
#10	1½	100	10	SD10112R100	500	3	SD10112R500	3000	SD10112MB
#10	2½	100	6	SD10212R100	500	2	SD10212R500	2000	SD10212MB

These coated fasteners possess a level of corrosion resistance that makes them suitable for use in some exterior and corrosive environments and with some preservative-treated woods. For applications in higher-exposure applications, consider Type-300 series stainless-steel fasteners for superior corrosion resistance. See page 15 for additional important information before selecting a fastener for a specific application.

Exterior Wood Screws

Deck-Drive™ DSV WOOD Screw

Preservative-Treated Decking and Exterior Wood-to-Wood Applications

The DSV screw is a powerful fastening solution for preservative-treated decking applications. With its under-head nibs and fast-start tip, the DSV is ideally suited to be driven and countersunk into today's wood deck boards. The shank is designed to withstand the swelling and shrinkage that is common with fast-growth lumber. Available in hand-drive and in collated strips for use in our Quik Drive® auto-feed screw driving system, DSV screws are also offered in a variety of sizes to fasten fascia and trim.

Features:

- Low-torque threads allow up to 35% more screws to be driven on a battery charge
- Ribbed head design countersinks easily and provides a clean, finished appearance
- High-low tip provides fast starts
- Optimized threads for dimensional lumber
- Quik Guard coating provides corrosion resistance for exterior and certain preservative-treated wood applications
- Tan color blends in with most woods
- T-25 6-lobe driver bit included (replacement driver bit – BIT25T-2)

This screw is also available collated for the Quik Drive® system. See page 174 for details.

U.S. Patent 6,074,149

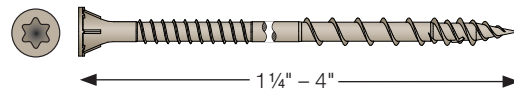

Quik Guard® Coating

Size	Length (in.)	Approx. Count Per Pound	1 lb. Model No.	5 lb. Model No.	350 ct. Model No.	Mini-Bulk	
						Model No.	Count
#8	1¼	194	DSVT114R1LB	DSVT114R5LB	DSVT114R350	DSVT114MB	1750
#8	1½	159	DSVT158R1LB	DSVT158R5LB	DSVT158R350	DSVT158MB	1750
#10	2	113	DSVT2R1LB	DSVT2R5LB	DSVT2R350	DSVT2MB	1750
#10	2½	91	DSVT212R1LB	DSVT212R5LB	DSVT212R350	DSVT212MB	1750
#10	3	76	DSVT3R1LB	DSVT3R5LB	DSVT3R350	DSVT3MB	1750
#10	3½	66	DSVT312R1LB	DSVT312R5LB	DSVT312R350	DSVT312MB	1000
#10	4	59	DSVT4R1LB	DSVT4R5LB	DSVT4R350	DSVT4MB	1000

- These coated fasteners possess a level of corrosion resistance that makes them suitable for use in some exterior and corrosive environments and with some preservative-treated woods. For applications in higher-exposure applications, consider Type-300 series stainless-steel fasteners for superior corrosion resistance. See page 15 for additional important information before selecting a fastener for a specific application.

Exterior Wood Screws

Deck-Drive™ DWP WOOD SS Screw

Decking, Docks and Boardwalks; Finishing, Millwork and Trim

The DWP screw is a powerful fastening solution for deck, dock, and general exterior applications where extra corrosion protection is needed. With its specially designed sharp-point and unique box-threads, the DWP is ideally suited for the majority of wood used in today's deck boards. Choose Type 316 stainless steel for seaside and coastal environments. Available in hand-drive and in collated strips for use in our Quik Drive® auto-feed screw driving system, DWP screws are also offered in a variety of sizes to fasten fascia and trim.

Features:

- Unique "box" thread design with raised-ridge technology greatly reduces driving torque, which allows you to drive more screws on a single battery charge
- Specially-designed sharp point penetrates hard wood products with ease
- 6-lobe drive helps prevent driver-bit cam-out, resulting in easier driving and longer bit life
- Choose Type 316 stainless steel for seaside applications and superior corrosion resistance

This screw is also available collated for the Quik Drive® system.

See page 174 for details.

Flat-Head

Type 316 Stainless Steel

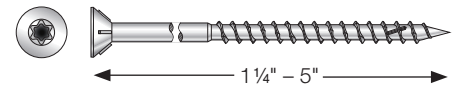

Size	Length (in.)	Head Diameter	Bit Size	Approx. Count Per lb.	1 lb. Model No.	5 lb. Model No.	Deck Pack		Bulk Bucket	
							Count	Model No.	Count	Model No.
#8	1 1/4	0.34	T20	185	T08125WP1	T081252WP5	—	—	5000	T08125WPB
#8	1 5/8	0.34	T20	150	T08162WP1	—	350	T08162WPP	4000	T08162WPB
#8	2	0.34	T20	128	T08200WP1	T08200WP5	350	T08200WPP	3000	T08200WPB
#8	2 1/2	0.34	T20	102	T08250WPF1	T08250WPF5	—	—	1750	T08250WPFB
#8	3	0.34	T20	82	T08300WPF1	T08300WPF5	—	—	1750	T08300WPFB
#10	2	0.34	T25	96	T10200WP1	T10200WP5	—	—	2500	T10200WPB
#10	2 1/2	0.34	T25	82	T10250WP1	T10250WP5	350	T10250WPP	1750	T10250WPB
#10	3	0.34	T25	68	T10300WP1	T10300WP5	350	T10300WPP	1750	T10300WPB
#10	3 1/2	0.34	T25	56	T10350WP1	—	250	T10350WPP	1000	T10350WPB
#10	4 1/2	0.34	T25	43	—	—	—	—	1000	T10450WPCM
#12	2 1/2	0.44	T27	56	T12250WP1	T12250WP5	—	—	1750	T12250WPB
#12	3 1/2	0.44	T27	42	T12350WP1	T12350WP5	—	—	1000	T12350WPB
#12	4	0.44	T27	36	T12400WP1	T12400WP5	100	T12400WPP	750	T12400WPB
#12	4 1/2	0.44	T27	32	T12450WP1	T12450WP5	—	—	750	T12450WPB
#12	5	0.44	T27	29	T12500WP1	T12500WP5	—	—	500	T12500WPB
#14	4	0.46	T27	26	—	T14400WP5	100	T14400WPP	700	T14400WPB

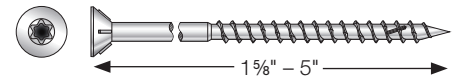

Type 305 Stainless Steel

Size	Length (in.)	Head Diameter	Bit Size	Approx. Count Per lb.	1 lb. Model No.	5 lb. Model No.	Deck Pack		Bulk Bucket	
							Count	Model No.	Count	Model No.
#8	1 5/8	0.34	T20	150	S08162WP1	S08162WP5	350	S08162WPP	4000	S08162WPB
#8	2	0.34	T20	128	S08200WP1	S08200WP5	350	S08200WPP	3000	S08200WPB
#8	2 1/2	0.34	T20	102	S08250WPF1	S08250WPF5	—	—	1750	S08250WPFB
#8	3	0.34	T20	82	S08300WPF1	S08300WPF5	—	—	1750	S08300WPFB
#10	1	0.34	T25	172	S10100WP1	S10100WP5	—	—	4500	S10100WPB
#10	1 1/2	0.34	T25	134	S10150WP1	S10150WP5	—	—	3500	S10150WPB
#10	2	0.34	T25	96	S10200WP1	S10200WP5	—	—	2500	S10200WPB
#10	2 1/2	0.34	T25	82	S10250WP1	S10250WP5	350	S10250WPP	1750	S10250WPB
#10	3	0.34	T25	68	S10300WP1	S10300WP5	350	S10300WPP	1750	S10300WPB
#10	3 1/2	0.34	T25	56	S10350WP1	S10350WP5	—	—	1000	S10350WPB
#12	2 1/2	0.44	T27	56	S12250WP1	S12250WP5	—	—	1750	S12250WPB
#12	3 1/2	0.44	T27	42	S12350WP1	S12350WP5	—	—	1000	S12350WPB
#12	4	0.44	T27	36	S12400WP1	S12400WP5	100	S12400WPP	800	S12400WPB
#12	4 1/2	0.44	T27	32	S12450WP1	S12450WP5	—	—	750	S12450WPB
#12	5	0.44	T27	29	S12500WP1	S12500WP5	—	—	500	S12500WPB
#14	4	0.46	T27	26	—	S14400WP5	100	S14400WPP	700	S14400WPB

Exterior Wood Screws

Deck-Drive™

DWP WOOD SS Screw (cont.)

Decking, Docks and Boardwalks; Finishing, Millwork and Trim

Trim-Head, Unpainted

Type 316 Stainless Steel

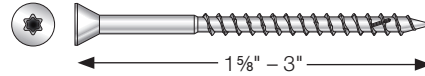

Size	Length (in.)	Head Diameter	Bit Size	Approx. Count Per lb.	1 lb. Model No.	5 lb. Model No.	Clam Shell		350-Count Model No.	Bulk Bucket	
							Count	Model No.		Count	Model No.
#7	1 5/8	0.23	T15	195	T07162WP1	T07162WP5	100	T07162FWP	T07162WPP	4000	T07162WPB
#7	2 1/4	0.23	T15	138	T07225WP1	T07225WP5	86	T07225FWP	T07225WPP	1750	T07225WPB
#7	3	0.23	T15	98	T07300WP1	—	60	T07300FWP	T07300WPP	1750	T07300WPB

Type 305 Stainless Steel

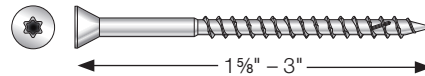

Size	Length (in.)	Head Diameter	Bit Size	Approx. Count Per lb.	1 lb. Model No.	5 lb. Model No.	Clam Shell		350-Count Model No.	Bulk Bucket	
							Count	Model No.		Count	Model No.
#7	1 5/8	0.23	T15	195	S07162WP1	S07162WP5	—	—	S07162WPP	4000	S07162WPB
#7	2 1/4	0.23	T15	138	S07225WP1	S07225WP5	—	—	S07225WPP	1750	S07225WPB
#7	3	0.23	T15	98	S07300WP1	S07300WP5	—	—	—	1750	S07300WPB
#8	2 1/2	0.26	T20	109	—	—	70	S08250FWP	S08250WPP	1750	S08250WPB
#8	3	0.26	T20	91	—	—	70	S08300FWP	S08300WPP	1750	S08300WPB

Trim-Head, Painted

- Durable coated finish – painted heads blend with hardwood decking material

Type 316 Stainless Steel

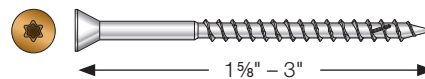

Size	Length (in.)	Head Diameter* (in.)	Bit Size	350-Count Model No.	1750-Count Model No.
#7	1 5/8	0.230	T15	T07162WJI	T07162WCI
#7	2 1/4	0.230	T15	T07225WJI	T07225WCI
#7	3	0.230	T15	T07300WJI	T07300WCI



* T-15 6-lobe drive (replacement bit model BIT15T-2, see page 133 for more information)

Type 305 Stainless Steel

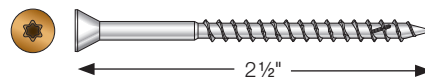

Size	Length (in.)	Head Diameter* (in.)	Bit Size	350-Count Model No.	1750-Count Model No.
#8	2 1/2	0.260	T20	S08250WJI	S08250WCI



* T-20 6-lobe drive (replacement bit model BIT20T-2, see page 133 for more information)

Exterior Wood Screws

Deck-Drive™ DHPD HARDWOOD Screw

Hardwood Decking, Docks and Boardwalks

The DHPD hardwood decking screw is specially designed to penetrate the hardest wood products with ease. With its unique paddle-style drill point, it virtually eliminates splitting without predrilling. The wings on the shaft counterbore hard material, allowing the head to countersink easily for a clean finished look. Available in Type 305 stainless steel for additional corrosion protection.

Features:

- Penetrate the hardest wood products without predrilling
- Compact head ensures a low-profile installation and reduced visibility
- Wings on the shaft counter-bore hard material and allow the head to countersink for a clean look
- Driver bit included in each package
- #2 square drive (replacement bit model BIT2S-2, see page 133 for more information)

This screw is also available collated for the Quik Drive® system. See page 175 for details.

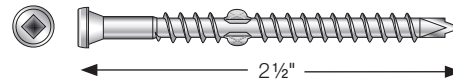

Type 305 Stainless Steel

Size	Length (in.)	Head Diameter (in.)	100-Count Model No.	350-Count Model No.	1000-Count Model No.	1750-Count Model No.
#10	2½	0.299	DHPDSS212R100	DHPDSS212R350	DHPDSS212R1000	DHPDSS212MB

Exterior Wood Screws

Bugle-Head Wood Decking Screw – 6-Lobe Drive

Common Application:

Fasten all types of wood decking including cedar, redwood and preservative-treated woods (*non-hardwood*)

Features:

- Available in Types 316 and 305 stainless steel
- Type-17 point for fast starts
- Coarse threads on approximately 2/3 of the shank draw the decking and other material tightly to the framing
- 6-lobe drive helps prevent driver-bit cam-out, resulting in easier driving and longer bit life
- 350-count packs contain enough screws to fasten 100 sq. ft. of decking (6" nominal-width boards installed on 16" o.c. joists)
- Choose Type 316 for seaside applications and superior corrosion resistance
- Driver bit included in each package
- Pre-drilling recommended near board ends to prevent splitting
- #6 screws: T-15 6-lobe drive (replacement bit model BIT15T-2)
- #8 screws: T-20 6-lobe drive (replacement bit model BIT20T-2)
- #10 screws: T-25 6-lobe drive (replacement bit model BIT25T-2)
- See page 133 for information on replacement driver bits

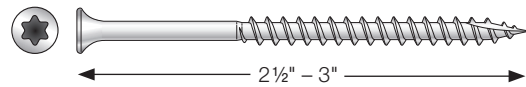

Type 316 Stainless Steel

Size	Length (in.)	Head Diameter (in.)	Approx. Count per lb.	1 lb. Model No.	5 lb. Model No.	350-Count Model No.	Bulk Bucket	
							Count	Model No.
#10	2½	0.344	82	T10250DT1	T10250DT5	T10C250DTP	2000	T10250DTB
#10	3	0.344	68	T10300DT1	T10300DT5	T10C300DTP	1500	T10300DTB

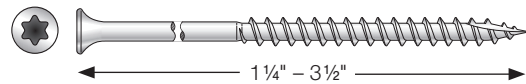

Type 305 Stainless Steel

Size	Length (in.)	Head Diameter (in.)	Approx. Count per lb.	1 lb. Model No.	5 lb. Model No.	350-Count Model No.	Bulk Bucket	
							Count	Model No.
#6	1¼	0.344	243	S06125DT1	S06125DT5	—	5000	S06125DTB
#8	1½	0.344	150	S08162DT1	S08162DT5	—	4000	S08162DTB
#8	2	0.344	128	S08200DT1	S08200DT5	—	3000	S08200DTB
#10	2½	0.344	82	S10250DT1	S10250DT5	S10C250DTP	2000	S10250DTB
#10	3	0.344	68	S10300DT1	S10300DT5	S10C300DTP	1500	S10300DTB
#10	3½	0.344	56	S10350DT1	S10350DT5	—	1000	S10350DTB

Exterior Wood Screws

Bugle-Head Wood Decking Screw – Square Drive

Common Application:

Fasten all types of wood decking including cedar, redwood and preservative-treated woods (*non-hardwood*)

Features:

- Available in Types 316 and 305 stainless steel
- Type-17 point for fast starts
- Coarse threads approximately ¾ up the shank draw the decking and other material tightly to the substrate
- 350-count packs contain enough screws to fasten 100 sq. ft. of decking (6" nominal-width boards installed on 16" o.c. joists)
- Choose Type 316 stainless steel for seaside applications and superior corrosion resistance
- Driver bit included in each package
- Pre-drilling recommended near board ends to prevent splitting
- #6, #8 and #10 screws: #2 square drive (replacement bit model BIT2S-2)
- #12 and #14 screws: #3 square drive (replacement bit model BIT3S-2)
- See page 133 for information on replacement driver bits

Painted

- Durable, coated finish – painted heads blend with decking material
- These screws are special-order, non-stock items and are subject to minimum order quantities and longer lead times. Call Simpson Strong-Tie for details.
- See pages 20-21 for Color Reference Chart for Decking Manufacturers

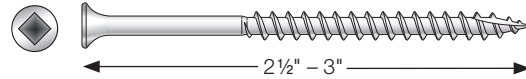

Type 305 Stainless Steel

Size	Length (in.)	Head Diameter (in.)	Head Color	40-Count Model No.	350-Count Model No.	1750-Count Model No.
#10	2½	0.344	Ipê	—	S10250DJI	S10250DCI
#10	2½	0.344	Tan	—	S10250DJT	S10250DCT
#10	3	0.344	Gray	—	S10300DJG	S10300DCG
#10	3	0.344	Ipê	S10C300DPI	S10300DJI	S10300DCI
#10	3	0.344	Tan	S10C300DPT	S10300DJT	S10300DCT



Unpainted

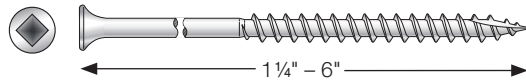

Type 316 Stainless Steel

Size	Length (in.)	Head Diameter (in.)	Approx. Count per lb.	1 lb. Model No.	5 lb. Model No.	350-Count Model No.	Bulk Bucket	
							Count	Model No.
#8	1¼	0.344	185	T08125DB1	T08125DB5	T08C125PAK	5000	T08125DBB
#8	1½	0.344	150	T08162DB1	T08162DB5	T08C162PAK	4000	T08162DBB
#8	2	0.344	128	T08200DB1	T08200DB5	T08C200PAK	3000	T08200DBB
#8	2½	0.344	102	T08250DB1	T08250DB5	T08C250PAK	2000	T08250DBB
#10	2	0.344	96	T10200DB1	T10200DB5	—	2500	T10200DBB
#10	2½	0.344	82	T10250DB1	T10250DB5	T10C250PAK	2000	T10250DBB
#10	3	0.344	68	T10300DB1	T10300DB5	T10C300PAK	1500	T10300DBB
#10	3½	0.344	56	T10350DB1	T10350DB5	T10C350PAK	1000	T10350DBB
#12	2½	0.430	56	T12250DB1	T12250DB5	—	2000	T12250DBB
#12	3	0.430	48	T12300DB1	T12300DB5	—	1500	T12300DBB
#12	3½	0.430	42	T12350DB1	T12350DB5	—	1000	T12350DBB
#12	4	0.430	36	T12400DB1	T12400DB5	—	800	T12400DBB
#12	4½	0.430	32	T12450DB1	T12450DB5	—	750	T12450DBB
#12	5	0.430	29	T12500DB1	T12500DB5	—	500	T12500DBB
#12	5½	0.430	28	T12550DB1	T12550DB5	—	500	T12550DBB
#12	6	0.430	24	T12600DB1	T12600DB5	—	600	T12600DBB
#14	3	0.430	36	T14300DB1	T14300DB5	—	1000	T14300DBB
#14	3½	0.430	33	T14350DB1	T14350DB5	—	750	T14350DBB
#14	4	0.430	26	T14400DB1	T14400DB5	—	700	T14400DBB
#14	5	0.430	21	T14500DB1	T14500DB5	—	500	T14500DBB
#14	6	0.430	18	T14600DB1	T14600DB5	—	500	T14600DBB

Exterior Wood Screws

Bugle-Head Wood Decking Screw – Square Drive (cont.)

Type 305 Stainless Steel

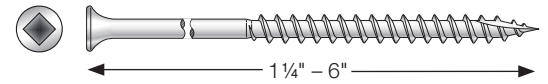

Size	Length (in.)	Head Diameter (in.)	Approx. Count per lb.	Clam Shell		1 lb. Model No.	5 lb. Model No.	350-Count Model No.	Bulk Bucket	
				Count	Model No.				Count	Model No.
#6	5/8	0.344	408	—	—	S06062DB1	S06062DB5	—	12,000	S06062DBB
#6	3/4	0.344	352	—	—	S06075DB1	S06075DB5	—	10,000	S06075DBB
#6	1	0.344	295	—	—	S06100DB1	S06100DB5	—	8000	S06100DBB
#6	1 1/4	0.344	243	175	S06C125DBP	S06125DB1	S06125DB5	—	5000	S06125DBB
#6	1 5/8	0.344	195	135	S06C162DBP	S06162DB1	S06162DB5	—	4000	S06162DBB
#8	3/4	0.344	285	—	—	S08075DB1	S08075DB5	—	10,000	S08075DBB
#8	1 1/8	0.344	226	—	—	S08112DB1	S08112DB5	—	5000	S08112DBB
#8	1 1/4	0.344	185	—	—	S08125DB1	S08125DB5	S08C125PAK	5000	S08125DBB
#8	1 5/8	0.344	150	—	—	S08162DB1	S08162DB5	S08C162PAK	4000	S08162DBB
#8	2	0.344	128	85	S08C200DBP	S08200DB1	S08200DB5	S08C200PAK	3000	S08200DBB
#8	2 1/4	0.344	109	—	—	S08225DB1	S08225DB5	S08C225PAK	3000	S08225DBB
#8	2 1/2	0.344	102	—	—	S08250DB1	S08250DB5	S08C250PAK	2000	S08250DBB
#8	3	0.344	82	—	—	S08300DB1	S08300DB5	S08C300PAK	1500	S08300DBB
#10	1	0.344	172	—	—	S10100DB1	S10100DB5	—	4500	S10100DBB
#10	1 1/4	0.344	153	—	—	S10125DB1	S10125DB5	—	4000	S10125DBB
#10	1 1/2	0.344	134	—	—	S10150DB1	S10150DB5	—	3500	S10150DBB
#10	1 3/4	0.344	115	—	—	S10175DB1	S10175DB5	—	3000	S10175DBB
#10	2	0.344	96	—	—	S10200DB1	S10200DB5	—	2500	S10200DBB
#10	2 1/4	0.344	88	—	—	S10225DB1	S10225DB5	—	2000	S10225DBB
#10	2 1/2	0.344	82	50	S10C250DBP	S10250DB1	S10250DB5	S10C250PAK	2000	S10250DBB
#10	3	0.344	68	40	S10C300DBP	S10300DB1	S10300DB5	S10C300PAK	1500	S10300DBB
#10	3 1/2	0.344	56	35	S10C350DBP	S10350DB1	S10350DB5	S10C350PAK	1000	S10350DBB
#10	3 3/4	0.344	54	—	—	S10375DB1	S10375DB5	—	1000	S10375DBB
#12	2 1/2	0.430	56	—	—	S12250DB1	S12250DB5	—	2000	S12250DBB
#12	3	0.430	48	—	—	S12300DB1	S12300DB5	—	1500	S12300DBB
#12	3 1/2	0.430	42	—	—	S12350DB1	S12350DB5	—	1000	S12350DBB
#12	4	0.430	36	—	—	S12400DB1	S12400DB5	—	800	S12400DBB
#12	4 1/2	0.430	32	—	—	S12450DB1	S12450DB5	—	750	S12450DBB
#12	5	0.430	29	—	—	S12500DB1	S12500DB5	—	500	S12500DBB
#12	5 1/2	0.430	28	—	—	S12550DB1	S12550DB5	—	500	S12550DBB
#12	6	0.430	24	—	—	S12600DB1	S12600DB5	—	600	S12600DBB
#14	3	0.430	36	—	—	S14300DB1	S14300DB5	—	1000	S14300DBB
#14	3 1/2	0.430	33	—	—	S14350DB1	S14350DB5	—	750	S14350DBB
#14	4	0.430	26	—	—	S14400DB1	S14400DB5	—	700	S14400DBB
#14	5	0.430	21	—	—	S14500DB1	S14500DB5	—	500	S14500DBB

Exterior Wood Screws

Trim-Head Wood Decking Screw – Square Drive

Common Application:

Fasten wood decking and some composite decking materials

Features:

- Trim-style head is less noticeable on the decking surface
- Type-17 point for fast starts
- Coarse threads on approximately 2/3 of the shank draw the decking and other material tightly to the framing
- Driver bit included in each package
- 350-count packs contain enough screws to fasten 100 sq. ft. of decking (6" nominal-width boards installed on 16" o.c. joists)
- Choose Type 316 stainless steel for seaside applications and superior corrosion resistance
- Pre-drilling recommended near board ends to prevent splitting
- #7 and #9 x 3 1/2" screws: #1 square drive (replacement bit model BIT1S-2)
- #9 x 4" screw: #2 square drive (replacement bit model BIT2S-2)
- See page 133 for more information on bits

Painted

- Heads colored to match Azek® PVC decking, and also match a wide variety of decking colors from other manufacturers
- See pages 20-21 for Color Reference Chart for Decking Manufacturers

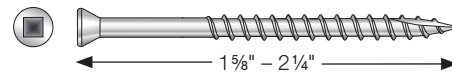

Type 316 Stainless Steel

Size	Length (in.)	Head Diameter (in.)	Head Color	350-Count Model No.	1750-Count Model No.
#7	1 5/8"	0.230	Gray	T07162FJG	T07162FCG
#7	1 5/8"	0.230	TN03	T07162FJI	T07162FCI
#7	1 5/8"	0.230	Tan	T07162FJT	T07162FCT
#7	1 5/8"	0.230	WH01	T07162FJW	T07162FCW
#7	2 1/4"	0.230	Gray	T07225FJG	T07225FCG
#7	2 1/4"	0.230	TN03	T07225FJI	T07225FCI
#7	2 1/4"	0.230	Tan	T07225FJT	T07225FCT
#7	2 1/4"	0.230	WH01	T07225FJW	T07225FCW



Type 305 Stainless Steel

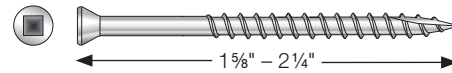

Size	Length (in.)	Head Diameter (in.)	Head Color	1 lb. Model No.	5 lb. Model No.	350-Count Model No.	1750-Count Model No.
#7	1 5/8"	0.230	WH01	S07162FW1	—	—	—
#7	2 1/4"	0.230	WH01	S07225FW1	S07225FW5	S07225FJW	S07225FCW
#7	2 1/4"	0.230	BR02	—	—	S07225FKJ	S07225FKB
#7	2 1/4"	0.230	TN02	—	—	S07225FJM	S07225FCM
#7	2 1/4"	0.230	GR03	—	—	S07225FJK	S07225FBK
#7	2 1/4"	0.230	TN04	—	—	S07225FJTN04	S07225FCTN04
#7	2 1/4"	0.230	TN03	—	—	S07225FJI	S07225FCI
#7	2 1/4"	0.230	WH02	—	—	S07225FJA	S07225FCA
#7	2 1/4"	0.230	BR03	—	—	S07225FJBR03	S07225FCBR03
#7	2 1/4"	0.230	RD02	—	—	S07225FJRD02	S07225FCRD02
#7	2 1/4"	0.230	BR04	—	—	S07225FJBR04	S07225FCBR04
#7	2 1/4"	0.230	GR02	—	—	S07225FZJ	S07225FCZ
#7	2 1/4"	0.230	GR02	—	—	S07225FJG	S07225FCG



Exterior Wood Screws

Trim-Head Wood Decking Screw – Square Drive (cont.)

Unpainted

Type 316 Stainless Steel

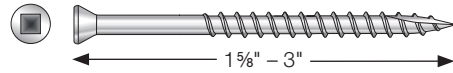

Size	Length (in.)	Head Diameter (in.)	Approx. Count per lb.	1 lb. Model No.	5 lb. Model No.	100-Count Model No.	350-Count Model No.	Bulk Bucket	
								Count	Model No.
#7	1½	0.230	195	T07162FB1	T07162FB5	T07162FBH	T07C162PAK	4000	T07162FBB
#7	2¼	0.230	138	T07225FB1	T07225FB5	T07225FBH	T07C225PAK	3000	T07225FBB
#7	3	0.230	98	T07300FB1	T07300FB5	T07300FBH	T07C300PAK	2000	T07300FBB

Type 305 Stainless Steel

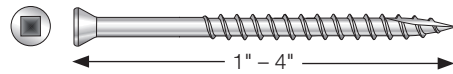

Size	Length (in.)	Head Diameter (in.)	Approx. Count per lb.	1 lb. Model No.	5 lb. Model No.	Clam Shell		350-Count Model No.	Bulk Bucket	
						Count	Model No.		Count	Model No.
#7	1	0.230	316	S07100FB1	S07100FB5	100	S07100FBH	S07C100PAK	5000	S07100FBB
#7	1¼	0.230	256	S07125FB1	S07125FB5	100	S07125FBH	S07C125PAK	5000	S07125FBB
#7	1½	0.230	195	S07162FB1	S07162FB5	135	S07C162FBP	S07C162PAK	4000	S07162FBB
#7	2	0.230	154	S07200FB1	S07200FB5	100	S07200FBH	S07C200PAK	4000	S07200FBB
#7	2¼	0.230	138	S07225FB1	S07225FB5	100	S07C225FBP	S07C225PAK	3000	S07225FBB
#7	2½	0.230	126	S07250FB1	S07250FB5	100	S07250FBH	S07C250PAK	2500	S07250FBB
#7	3	0.230	98	S07300FB1	S07300FB5	60	S07C300FBP	S07C300PAK	2000	S07300FBB
#9	3½	0.250	62	S09350FB1	S09350FB5	35	S09C350FBP	S09C350PAK	1500	S09350FBB
#9	4	0.250	61	S09400FB1	S09400FB5	—	—	—	1000	S09400FBB

Exterior Wood Screws

Trim-Head Wood Decking Screw – 6-Lobe Drive

Common Application:

Fasten wood decking and some composite decking materials

Features:

- Trim-style head is less noticeable on the decking surface
- Type-17 point for fast starts
- Coarse threads on approximately 2/3 of the shank draw the decking and other material tightly to the framing
- 6-lobe drive helps prevent driver-bit cam-out, resulting in easier driving and longer bit life
- 350-count packs contain enough screws to fasten 100 sq. ft. of decking (6" nominal-width boards installed on 16" o.c. joists)
- Choose Type 316 for seaside applications and superior corrosion resistance
- Pre-drilling recommended near board ends to prevent splitting
- T-15 6-lobe drive (replacement bit model BIT15T-2, see page 133 for more information)

Painted

- Heads colored to match "Trex Escapes®" PVC decking, and also match a wide variety of decking colors from other manufacturers
- See pages 20-21 for Color Reference Chart for Decking Manufacturers

Screws and Nails

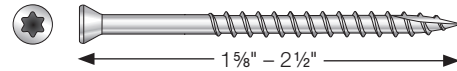

Type 316 Stainless Steel

Size	Length (in.)	Head Diameter (in.)	Head Color	350-Count Model No.	1750-Count Model No.
#8	2½	0.230	Almond	T08250FJA	T08250FCA
#8	2½	0.230	Gray	T08250FZJ	T08250FZC
#8	2½	0.230	GR03	T08250FJK	T08250FBK
#8	2½	0.230	TN02	T08250FJM	T08250FCM
#8	2½	0.230	White	T08250FJW	T08250FCW

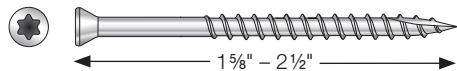
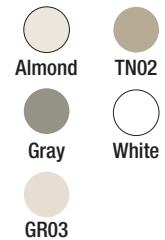

Type 305 Stainless Steel

Size	Length (in.)	Head Diameter (in.)	Head Color	1 lb. Model No.	5 lb. Model No.	70-Count Model No.	350-Count Model No.	1750-Count Model No.
#7	1½	0.230	White	S07162FTW1	—	—	S07162TJW	S07162TCW
#7	2¼	0.230	White	S07225BTW1	S07225BTW5	—	—	—
#7	2¼	0.230	Acorn	—	—	S07225TPA	S07225TJA	S07225TCA
#7	2¼	0.230	Black	—	—	—	S07225TJB	S07225TCB
#7	2¼	0.230	BR02	—	—	—	S07225TKJ	S07225TKC
#7	2¼	0.230	Gray	—	—	—	S07225TJG	S07225TCG
#7	2¼	0.230	Lt. Gray	—	—	S07225TPZ	S07225TJZ	S07225TCZ
#7	2¼	0.230	TN02	—	—	S07225TPM	S07225TJM	S07225TCM
#7	2¼	0.230	Pewter	—	—	S07225TPE	S07225TJE	S07225TCE
#7	2¼	0.230	Sahara	—	—	S07225TPS	S07225TJS	S07225TCS
#8	2½	0.230	RD02	—	—	—	S08250TJJ	S08250TCJ
#8	2½	0.230	Gray	—	—	—	S08250TJG	S08250TCG
#8	2½	0.230	Tan	—	—	—	S08250TJT	S08250TCT



Exterior Wood Screws

Trim-Head Wood Decking Screw – 6-Lobe Drive (cont.)

Unpainted

Type 316 Stainless Steel

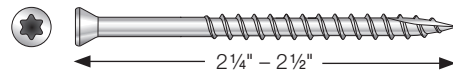

Size	Length (in.)	Head Diameter (in.)	1 lb. Model No.	5 lb. Model No.	350-Count Model No.	Bulk Bucket	
						Count	Model No.
#7	2¼	0.230	—	—	T07225FTP	3000	T07225FTB
#8	2½	0.230	T08250FT1	T08250FT5	—	2000	T08250FTB

Type 305 Stainless Steel

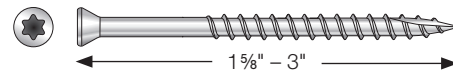

Size	Length (in.)	Head Diameter (in.)	1 lb. Model No.	5 lb. Model No.	350-Count Model No.	Bulk Bucket	
						Count	Model No.
#7	1⅝	0.230	S07162FT1	S07162FT5	S07162FTP	4000	S07162FTB
#7	2¼	0.230	S07225FT1	S07225FT5	S07225FTP	3000	S07225FTB
#7	3	0.230	S07300FT1	S07300FT5	S07300FTP	2000	S07300FTB

Composite Decking Screws

Dexxter™ Composite-Decking Screw

The Dexxter™ composite-decking screw is designed to ease installation and offer a cleaner, less noticeable fastening solution for composite and encapsulated-composite decking. Available in stainless steel and Quik Guard® coated for corrosion resistance. Choose Type 316 stainless steel for seaside and coastal environments.

Features:

- Unique thread formation removes excess decking material to ensure the screw is seated properly and consistently
- The trim pan head reduces the mushroom effect, common with traditional decking screws, leaving a smoother, clean-looking installation
- Quik Guard® coating on the carbon-steel version enables the screw to be used with many preservative-treated wood substrates
- Type-17 point easily pierces composite substrate for faster starts
- Head style minimizes visibility on the decking surface
- Driver bit included in every package
- #2 undersized square drive (replacement driver bit – BIT2SU-2)
- T-20 6-lobe drive (replacement driver bit – BIT20T-2)

U.S. Patent 7,402,016

Square Drive – Painted

- See pages 20-21 for Color Reference Chart for Decking Manufacturers

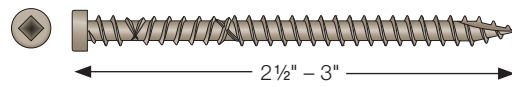

Quik Guard® Coating

Size	Length (in.)	Head Color	350-Count Model No.	1750-Count Model No.
#10	2½	Brown 01	DDX212BR01R350	DDX212BR01MB
#10	2½	Gray 01	DDX212GR01R350	DDX212GR01MB
#10	2½	Gray 04	DDX212GR04R350	DDX212GR04MB
#10	2½	Red 01	DDX212RD01R350	DDX212RD01MB
#10	2½	Tan 01	DDX212TN01R350	DDX212TN01MB
#10	2½	Tan 02	DDX212TN02R350	DDX212TN02MB
#10	3	Brown 01	DDX3BR01R350	DDX3BR01MB
#10	3	Gray 01	DDX3GR01R350	DDX3GR01MB
#10	3	Gray 04	DDX3GR04R350	DDX3GR04MB
#10	3	Red 01	DDX3RD01R350	DDX3RD01MB
#10	3	Tan 01	DDX3TN01R350	DDX3TN01MB
#10	3	Tan 02	DDX3TN02R350	DDX3TN02MB



These coated fasteners possess a level of corrosion resistance that makes them suitable for use in some exterior and corrosive environments and with some preservative-treated woods. For applications in higher-exposure applications, consider Type-300 series stainless-steel fasteners for superior corrosion resistance. See page 15 for additional important information before selecting a fastener for a specific application.

Composite Decking Screws

Dexxter™ Composite-Decking Screw (cont.)

6-Lobe Drive – Painted

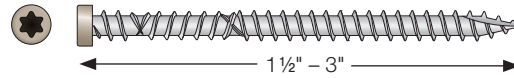

Type 305 Stainless Steel

Size	Length (in.)	Head Color	70-Count Model No.	350-Count Model No.	1750-Count Model No.
#10	1 1/2	Brown01	S10150XCB	S10150XPB	S10150XBB
#10	1 1/2	Gray	S10150XCG	S10150XPG	S10150XBG
#10	1 1/2	Tan 03 (Ipé)	S10150XCI	S10150XPI	S10150XBI
#10	1 1/2	Redwood	S10150XCR	S10150XPR	S10150XBR
#10	1 1/2	Tan	S10150XCT	S10150XPT	S10150XBT
#10	2 1/2	Brown 01	S10250XCBR01	S10250XPBR01	S10250XBBR01
#10	2 1/2	Gray	S10250XCG	S10250XPG	S10250XBG
#10	2 1/2	Gray 01	—	S10250XPGR01	S10250XBGR01
#10	2 1/2	Gray 04	—	S10250XPGR04	S10250XBGR04
#10	2 1/2	Tan 03 (Ipé)	S10250XCI	S10250XPI	S10250XBI
#10	2 1/2	Red 01	—	S10250XPRD01	S10250XBRD01
#10	2 1/2	Redwood	S10250XCR	S10250XPR	S10250XBR
#10	2 1/2	Tan	S10250XCT	S10250XPT	S10250XBT
#10	2 1/2	Tan 01	—	S10250XPTN01	S10250XBTN01
#10	2 1/2	Tan 02	—	S10250XPTN02	S10250XBTN02
#10	3	Brown 01	—	S10300XPBR01	S10300XBBR01
#10	3	Gray	S10300XCG	S10300XPG	S10300XBG
#10	3	Gray 01	—	S10300XPGR01	S10300XBGR01
#10	3	Gray 04	—	S10300XPGR04	S10300XBGR04
#10	3	Tan 03 (Ipé)	S10300XCI	S10300XPI	S10300XBI
#10	3	Red 01	—	S10300XPRD01	S10300XBRD01
#10	3	Redwood	S10300XCR	S10300XPR	S10300XBR
#10	3	Tan	S10300XCT	S10300XPT	S10300XBT
#10	3	Tan 01	—	S10300XPTN01	S10300XBTN01
#10	3	Tan 02	—	S10300XPTN02	S10300XBTN02



Screws and Nails

6-Lobe Drive – Unpainted

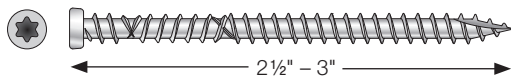

Type 316 Stainless Steel

Size	Length (in.)	350-Count Model No.	1750-Count Model No.
#10	2 1/2	T10250DXP	T10250DXB
#10	3	T10300DXP	T10300DXB

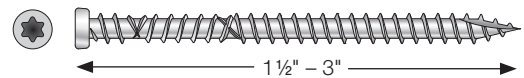

Type 305 Stainless Steel

Size	Length (in.)	70-Count Model No.	350-Count Model No.	1750-Count Model No.
#10	1 1/2	S10150DXC	S10150DXP	S10150DXB
#10	2	—	S10200DXP	S10200DXB
#10	2 1/2	S10250DXC	S10250DXP	S10250DXB
#10	3	S10300DXC	S10300DXP	S10300DXB

Composite Decking Screws

Composi-Lok™ Composite-Decking Screw

The Composi-Lok™ composite-decking screw is designed to fasten composite deck boards and provide a clean, finished look. The sharp-point penetrates the deckboard easily, while the cutting wings counter-bore, helping to prevent fastener spin out. Available in hand-drive and in collated strips for use in our Quik Drive® auto-feed screw driving system.

Features:

- Available with Quik Guard® coating in four colors and Type 305 stainless steel. For information on corrosion, materials and coatings, see page 15.
- Cap-style head reduces mushrooming composite material, ensuring a cleaner-looking installation
- Cutting wings on the shaft counter-bore the deck board, helping to prevent fastener spin out
- Sharp point penetrates composite substrates easily
- Driver bit included in each package
- #2 undersized square drive (replacement bit model BIT2SU-2, see page 133 for more information)

This screw is also available collated for the Quik Drive® system. See page 186 for details.

Painted

- See pages 20-21 for Color Reference Chart for Decking Manufacturers

Quik Guard® Coating

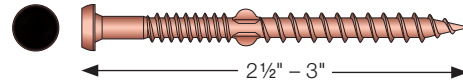

Size	Length (in.)	Head Diameter (in.)	Color	350-Count Model No.	1750-Count Model No.
#9	2½	0.299	Brown	DCLB212R350	DCLB212MB
#9	2½	0.299	Gray	DCLG212R350	DCLG212MB
#9	2½	0.299	Red	DCLR212R350	DCLR212MB
#9	2½	0.299	Tan	DCLT212R350	DCLT212MB
#9	3	0.299	Brown	DCLB3R350	DCLB3MB
#9	3	0.299	Gray	DCLG3R350	DCLG3MB
#9	3	0.299	Red	DCLR3R350	DCLR3MB
#9	3	0.299	Tan	DCLT3R350	DCLT3MB



Unpainted

Type 305 Stainless Steel

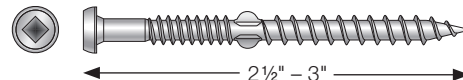

Size	Length (in.)	Head Diameter (in.)	350-Count Model No.	1750-Count Model No.
#9	2½	0.299	DCLSS212R350	DCLSS212MB
#9	3	0.299	DCLSS3R350	DCLSS3MB

These coated fasteners possess a level of corrosion resistance that makes them suitable for use in some exterior and corrosive environments and with some preservative-treated woods. For applications in higher-exposure applications, consider Type-300 series stainless-steel fasteners for superior corrosion resistance. See page 15 for additional important information before selecting a fastener for a specific application.

Interior Wood Screws

Strong-Drive® SDWC TRUSS Screw

Truss/Rafter-to-Plate and Stud-to-Plate Connections

The Strong-Drive® SDWC structural wood screw provides a stud-to-bottom plate or stud-to-top plate connection as well as fastening trusses and rafters to top plates. The full-threaded shank engages the entire length of the fastener providing a secure connection. The SDWC is tested in accordance with ICC-ES AC233 (screw) and AC13 (wall assembly and roof-to-wall assembly) for uplift and lateral loads between wall plates and vertical wall framing and between the top plate and the roof rafters or trusses.

Features:

- Fully-threaded shank engages the entire length of the fastener, providing a secure connection between the roof and wall framing members
- Cap-style head countersinks fully into the double top plate to avoid interference with drywall or finish trades
- Wide tolerance on installation angle makes it easy to install the SDWC correctly
- Can be installed from inside the structure, eliminating exterior work on the upper stories and enhancing job safety
- Fastening can be performed before or after exterior sheathing is applied for added flexibility
- Metal installation guide tool (included) to help ensure proper installation
- Matched-tolerance driver bit (included) engages fastener head securely to allow one-handed driving (replacement bit part no. BIT30T-R1)
- Orange color for easy inspection
- Type-17 point for faster starts and easier driving
- SDWC15450 is recognized for use in chemically treated wood as described in the evaluation report

Codes/Standards: IAPMO-UES ER-262

For Technical Data and Loads, see pages 294-300

SDWC15450-KT and SDWC15600-KT contains:

- (50) Strong-Drive® SDWC screws
- (1) Matched-tolerance driver bit (Part no. BIT30T-RT1; also sold separately)
- (1) Metal installation guide tool
 - SDWC-GUIDE (for SDWC15600 only; also sold separately) or
 - SDWC-GUIDE275 (for SDWC15450 only; also sold separately)



SDWC15450B-KT and SDWC15600B-KT contains:

- (500) Strong-Drive® SDWC screws
- (2) Matched-tolerance driver bits (Part no. BIT30T-RT1; also sold separately)
- (2) Metal installation guide tools
 - SDWC-GUIDE (for SDWC15600 only; also sold separately) or
 - SDWC-GUIDE275 (for SDWC15450 only; also sold separately)



E-Coat

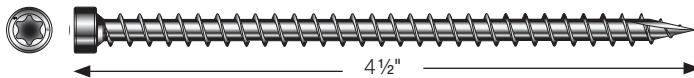

Size	Thread Length (in.)	Retail Pack ¹			Mini-Bulk Bucket ²	
		Fasteners Per Pack	Retail Per Master Carton	Model No.	Fasteners Per Bucket	Model No.
0.152 x 4 1/2	4 1/4	50	6	SDWC15450-KT	500	SDWC15450B-KT

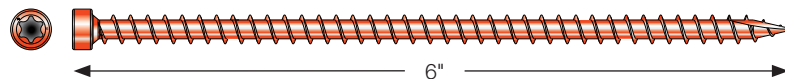

Clear Zinc Coating (with Orange Topcoat)

Size	Thread Length (in.)	Retail Pack ¹			Mini-Bulk Bucket ²	
		Fasteners Per Pack	Retail Per Master Carton	Model No.	Fasteners Per Bucket	Model No.
0.152 x 6	5 3/4	50	6	SDWC15600-KT	500	SDWC15600B-KT

Interior Wood Screws

Strong-Drive® SDW EWP-PLY Screw

Multi-Ply Wood Members, Engineered-Lumber Products and Solid-Sawn Lumber

The Strong-Drive® SDW EWP-Ply screw is a high-strength structural wood screw specifically designed for fastening multi-ply wood members, such as engineered-wood products and solid-sawn lumber. The SDW EWP-Ply installs easily with no pre-drilling and is available in optimized lengths for fastening 1 3/4" engineered lumber, such as structural composite lumber (SCL). The large, flush head eases the handling of assembled girders and simplifies the installation of finishes or structural connectors.

Features:

- Large washer head provides maximum bearing area; stamped with the Simpson Strong-Tie "S" sign and fastener length for easy identification after installation
- Deep 6-lobe recess reduces cam-out, making driving easier
- Low-profile head results in less interference after installation; makes stacking and sliding members easier and allows installation of hardware and finishes to be virtually flush
- Optimal screw lengths provide maximum penetration while preventing the point from protruding out the back of the member
- Specific thread lengths avoids jacking
- Higher shear values than competitive products enable wider spacing saving time and money
- Bold thread design provides superior holding power and cinches fastened members together for consistent installation
- Patented 4CUT™ point ensures fast starts, reduced installation torque and eliminates the need for pre-drilling in most applications
- Retail and mini-bulk packs include one deep, 6-lobe, T-40 driver bit; bulk packs include two driver bits

Codes/Standards: IAPMO-UES ER-192; City of L.A. RR25906

For Technical Data and Loads, see pages 301-303

U.S. Patents: 5,897,280; 7,101,133 and 6,109,850

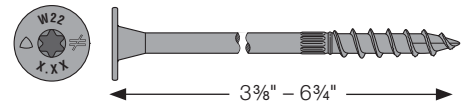

E-Coat

Size (in.)	Thread Length (in.)	Typical Application ¹	Retail Pack			Mini-Bulk Bucket		Bulk	
			Fasteners Per Pack	Packs Per Master Carton	Model No.	Fasteners Per Pack	Model No.	Fasteners Per Pack	Model No.
0.22 x 3 3/8	1 1/16	SCL	50	6	SDW22338-R50	250	SDW22338MB	900	SDW22338
0.22 x 5	1 1/16	SCL/3x2PCT	50	4	SDW22500-R50	200	SDW22500MB	600	SDW22500
0.22 x 6 3/4	1 1/16	SCL/4x2PCT	50	4	SDW22634-R50	200	SDW22634MB	500	SDW22634

1. Typical screw application key: SCL = 1 3/4" plies of structural-composite lumber. SCL/3x2PCT = 1 3/4" plies of structural-composite lumber or double 3x2 parallel-chord trusses. SCL/4x2PCT = 1 3/4" or 3 1/2" plies of structural-composite lumber or double 4x2 parallel-chord trusses.

Interior Wood Screws

Strong-Drive® SDW TRUSS-PLY Screw

Truss-Ply Fastening

The Strong-Drive® SDW Truss-Ply screw is a high-strength structural wood screw specifically designed for fastening multi-ply wood members, such as joining plated trusses and solid-sawn lumber. The SDW installs easily with no pre-drilling and is available in optimized lengths for fastening 2-, 3- and 4-ply trusses. With the SDW Truss-Ply screw, multi-ply trusses and beams can be fastened from one side without requiring the lifting and flipping of heavy assemblies.

Features:

- Large washer head provides maximum bearing area; stamped with the Simpson Strong-Tie "S" sign and fastener length for easy identification after installation
- Deep 6-lobe recess reduces cam-out, making driving easier
- Low-profile head results in less interference after installation; makes stacking and sliding members easier and allows installation of hardware and finishes to be virtually flush
- Higher shear values than competitive products enable wider spacing saving time and money
- Bold thread design provides superior holding power and cinches fastened members together for consistent installation
- Patented 4CUT™ point ensures fast starts, reduced installation torque and eliminates the need for pre-drilling in most applications
- Retail and mini-bulk packs include one deep, 6-lobe, T-40 driver bit; bulk packs include two driver bits

Codes/Standards: IAPMO-UES ER-192; City of L.A. RR25906

For Technical Data and Loads, see pages 301-303

U.S. Patents: 5,897,280; 7,101,133 and 6,109,850

E-Coat

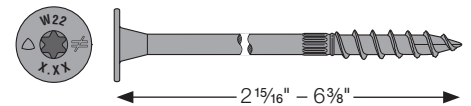

Size (in.)	Thread Length (in.)	Typical Application ^{1,2,3}	Retail Pack			Mini-Bulk Bucket		Bulk	
			Fasteners Per Pack	Packs Per Master Carton	Model No.	Fasteners Per Pack	Model No.	Fasteners Per Pack	Model No.
0.22 x 2 ¹ / ₁₆	1 ⁷ / ₁₆	2x/Truss	50	6	SDW22300-R50	250	SDW22300MB	950	SDW22300
0.22 x 4 ³ / ₈	1 ⁷ / ₁₆	2x/Truss Desert	50	4	SDW22438-R50	200	SDW22438MB	600	SDW22438
0.22 x 4 ⁵ / ₈	1 ⁷ / ₁₆	2x/Truss	50	4	SDW22458-R50	200	SDW22458MB	600	SDW22458
0.22 x 6	1 ⁷ / ₁₆	2x/Truss Desert	50	4	SDW22600-R50	200	SDW22600MB	500	SDW22600
0.22 x 6 ³ / ₈	1 ⁷ / ₁₆	2x/Truss	50	4	SDW22638-R50	200	SDW22638MB	500	SDW22638

1. Typical screw application key: 2x/Truss = Solid-sawn dimensional lumber and plated wood trusses. 2x Truss Desert = Solid-sawn dimensional lumber and plated wood trusses in desert environments (scant lumber).

2. If assembly is less than or equal to 4⁹/₁₆" thick, use the SDW22438.
3. If assembly is less than or equal to 6³/₈" thick, use the SDW22600.

Strong-Drive® SDWS LOG Screw

Log Home Construction and General Interior Applications

The Simpson Strong-Tie® Strong-Drive® SDWS line of screws has been expanded to include longer lengths designed for log-home construction. These .220" and .195" diameter structural fasteners require less torque to install than comparable fasteners. The large diameter head pulls logs down easily, eliminating the need to use extra washers.

Features:

- Patented 4CUT™ tip that ensures fast starts, reduces installation torque and eliminates the need for pre-drilling in most applications
- Low-profile head design makes countersinking easy
- Serrated thread reduces log splitting and damage
- Large washer head provides maximum bearing area
- Deep 6-lobe recess reduces cam-out, making driving easier
- Size Identification on all SDWS screw heads

Codes/Standards: IAPMO-UES ER-192

For Technical Data and Loads, see page 282

U.S. Patents: 5,897,280; 7,101,133

E-Coat

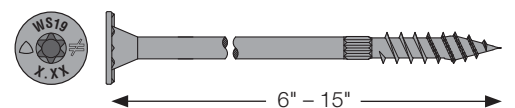

Fastener Length (in.)	Size Diameter (in.)	Thread Length (in.)	Fasteners Per Box	Model No.
6	0.195	2 ³ / ₄	250	SDWS19600
7 ¹ / ₂	0.195	2 ³ / ₄	250	SDWS19712
8	0.220	2 ³ / ₄	250	SDWS22800
9	0.220	2 ³ / ₄	250	SDWS22900
10	0.220	2 ³ / ₄	250	SDWS221000
11	0.220	2 ³ / ₄	250	SDWS221100
12	0.220	2 ³ / ₄	250	SDWS221200
15	0.220	2 ³ / ₄	200	SDWS221500

Interior Wood Screws

Strong-Drive® SDWF FLOOR-TO-FLOOR Screw

Wind-Uplift Restraint Connections

The Strong-Drive® SDWF floor-to-floor screw is designed to simplify the wind-uplift restraint connection while providing superior performance over the life of the structure. The unique design of the SDWF enables it to attach upper and lower walls together from the top, spanning the floor system and providing an easy-to-install connection within the continuous uplift load path of the structure.

The innovative TUW Take-Up Washer plays a key role in the long-term performance of the SDWF when installed between the screw and the sole plate of the upper floor. As the structure settles because of shrinkage and construction loading, the threaded portion under the head of the screw ratchets up through the tabs of the TUW, which is fastened with Simpson Strong-Tie Strong-Drive SD screw. The interlock between the tabs of the take-up washer and the threads under the head of the SDWF prevent the screw from sliding back under load, providing a simple yet reliable means of shrinkage compensation up to 3/4" per story.

Features:

- Faster to install than other floor-to-floor connection methods – drive the screw, install the take up washer and the connection is made from plate-to-plate
- Shrinkage compensation ensures a tight connection even after initial shrinkage and settlement occur
- Installs from inside the structure, eliminating exterior work on the upper stories and enhancing job safety
- Fastening can be done before or after exterior sheathing is applied for added flexibility
- One screw length can be used for multiple floor depths (refer to chart to select appropriate screw size), reducing the need for many screw lengths

Kit includes all required installation hardware:

- 25x Strong-Drive® SDWF Floor-to-Floor Screw
- 25x TUW Take-Up Washers
- 100x Strong-Drive® SD Connector Screws (#9)
- 3/16" Hex Driver Bit
- Screw Depth Guide to ensure proper SDWF engagement with TUW

TUW take-up washer is galvanized 10ga. steel

Codes/Standards: ICC-ES ESR-3046 (SDWF), ICC-ES ESR-2320 (TUW)

For Technical Data and Loads, see pages 304-306

U.S. Patent: 8,276,323

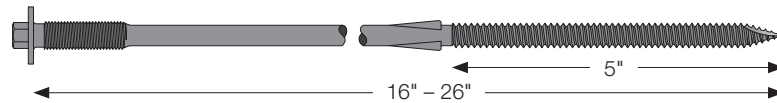

Length (in.)	Shank Diameter (in.)	Thread Length (in.)	Hex Drive (in.)	Model No.
16	0.27	5	5/16	SDWF2716-TUW
20	0.27	5	5/16	SDWF2720-TUW
24	0.27	5	5/16	SDWF2724-TUW
26	0.27	5	5/16	SDWF2726-TUW

Wafer-Head Screw

Common Application:

General Wood-to-Wood Fastening

Features:

- Wafer head
- Sharp point for fast starts
- Deep #2 Phillips drive reduces cam-out and makes driving easier
- Clear zinc electro galvanized finish. For information on corrosion, materials and coatings, see page 15.

For Technical Data and Loads, see page 326

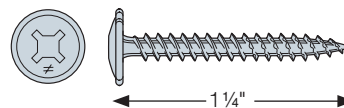

Clear Zinc Coating

Size	Length (in.)	Head Diameter (in.)	Carton Quantity	Model No.
#8	1 1/4	0.418	100	SD8x1.25

Exterior Nails

Premium Siding Nail

Common Application:

Siding in High-Exposure Environments

Features:

- Type 316 stainless steel for seaside applications and high exposure environments
- Passivated to remove dirt and swarf ensuring corrosion resistance
- Circle pattern head identifies product as Type 316, reduces glare, accepts surface finishes
- Annular ring shank increases pull out resistance, provides greater holding power and reduce cupping of siding.
- Blunt diamond point to drive true and reduce board splitting

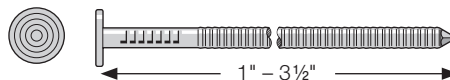

Type 316 Stainless Steel

Penny Size	Length (in.)	Wire Gauge	Shank Diameter (in.)	Head Diameter (in.)	Approx. Count per lb.	1 lb. Model No.	5 lb. Model No.	25 lb. Bucket Model No.
2d	1	15	0.072	5/32	807	T2KR51	T2KR55	T2KR5B
2d	1	14	0.083	7/32	530	T2KR71	T2KR75	T2KR7B
3d	1¼	14	0.083	5/32	495	T3KR51	T3KR55	T3KR5B
3d	1¼	14	0.083	7/32	470	T3KR71	T3KR75	T3KR7B
4d	1½	14	0.083	5/32	398	T4KR51	T4KR55	T4KR5B
4d	1½	14	0.083	7/32	394	T4KR71	T4KR75	T4KR7B
5d	1¾	14	0.083	5/32	354	T5KR51	T5KR55	T5KR5B
5d	1¾	14	0.083	7/32	337	T5KR71	T5KR75	T5KR7B
6d	2	14	0.083	5/32	402	T6KR51	T6KR55	T6KR5B
6d	2	14	0.083	7/32	261	T6KR71	T6KR75	T6KR7B
7d	2¼	13	0.092	5/32	215	T7KR51	T7KR55	T7KR5B
7d	2¼	13	0.092	7/32	216	T7KR71	T7KR75	T7KR7B
8d	2½	13	0.092	5/32	196	T8KR51	T8KR55	T8KR5B
8d	2½	13	0.092	7/32	196	T8KR71	T8KR75	T8KR7B
10d	3	12	0.113	7/32	120	T10KR71	T10KR75	T10KR7B
12d	3¼	12	0.113	7/32	110	T12KR71	T12KR75	T12KR7B
16d	3½	11	0.120	¼	88	T16KR41	T16KR45	T16KR4B

Premium Common Nail

Common Application:

Fastening in High-Exposure Environments

Features:

- Type 316 stainless steel for seaside applications and high exposure environments
- Passivated to remove dirt and swarf ensuring corrosion resistance
- Circle pattern head identifies product as Type 316, reduces glare, accepts surface finishes
- Annular ring shank increases pull out resistance, provides greater holding power and reduce cupping of siding.
- Blunt diamond point to drive true and reduce board splitting

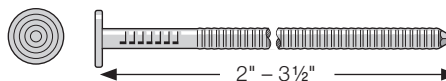

Penny Size	Length (in.)	Wire Gauge	Shank Diameter (in.)	Head Diameter (in.)	Approx. Count per lb.	1 lb. Model No.	5 lb. Model No.	25 lb. Bucket Model No.
6d	2	11	0.120	17/64	144	T6AKR1	T6AKR5	T6AKRB
8d	2½	10	0.131	9/32	94	T8AKR1	T8AKR5	T8AKRB
10d	3	9	0.148	5/16	67	T10AKR1	T10AKR5	T10AKRB
12d	3¼	9	0.148	5/16	60	T12AKR1	T12AKR5	T12AKRB
16d	3½	8	0.162	11/32	44	T16AKR1	T16AKR5	T16AKRB

Exterior Nails

Box Nail – Annular Ring Shank

Features:

- Checker pattern on heads blends with wood grain, reduces glare from sunlight and accepts surface finishes
- Annular ring shank increases withdrawal resistance to provide a secure attachment
- Stainless-steel nails are recommended for construction of permanent wood foundations by the *ANSI/AF&PA Permanent Wood Foundations Design Specifications*
- Choose Type 316 stainless steel for seaside applications and superior corrosion resistance
- **Special Order Options** – Call Simpson Strong-Tie for details (800) 999-5099
 - Spiral shank common, post-and-beam and box nails
 - Silicon-bronze nails

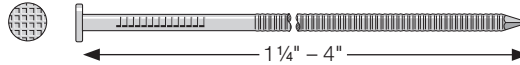

Type 316 Stainless Steel

Penny Size	Length (in.)	Gauge	Shank Diameter (in.)	Head Diameter (in.)	Approx. Count per lb.	1 lb. Model No.	5 lb. Model No.	25 lb. Bucket Model No.
3d	1¼	14	0.083	7/32	473	T3ABN1	T3ABN5	T3ABNB
4d	1½	14	0.083	7/32	413	T4ABN1	T4ABN5	T4ABNB
5d	1¾	13	0.092	13/64	260	T5ABN1	T5ABN5	T5ABNB
6d	2	12	0.113	17/64	175	T6ABN1	T6ABN5	T6ABNB
7d	2¼	12	0.113	17/64	153	T7ABN1	T7ABN5	T7ABNB
8d	2½	12	0.113	17/64	138	T8ABN1	T8ABN5	T8ABNB
10d	3	11	0.120	17/64	99	T10ABN1	T10ABN5	T10ABNB
12d	3¼	10	0.131	9/32	72	T12ABN1	T12ABN5	T12ABNB
16d	3½	10	0.131	9/32	67	T16ABN1	T16ABN5	T16ABNB
20d	4	8	0.162	11/32	40	T20ABN1	T20ABN5	T20ABNB

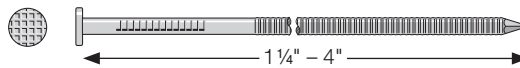

Type 304 Stainless Steel

Penny Size	Length (in.)	Gauge	Shank Diameter (in.)	Head Diameter (in.)	Approx. Count per lb.	1 lb. Model No.	5 lb. Model No.	25 lb. Bucket Model No.
3d	1¼	14	0.083	7/32	473	S3ABN1	S3ABN5	S3ABNB
4d	1½	14	0.083	7/32	413	S4ABN1	S4ABN5	S4ABNB
5d	1¾	13	0.092	13/64	260	S5ABN1	S5ABN5	S5ABNB
6d	2	12	0.113	17/64	175	S6ABN1	S6ABN5	S6ABNB
7d	2¼	12	0.113	17/64	153	S7ABN1	S7ABN5	S7ABNB
8d	2½	12	0.113	17/64	138	S8ABN1	S8ABN5	S8ABNB
10d	3	11	0.120	17/64	99	S10ABN1	S10ABN5	S10ABNB
12d	3¼	10	0.131	9/32	72	S12ABN1	S12ABN5	S12ABNB
16d	3½	10	0.131	9/32	67	S16ABN1	S16ABN5	S16ABNB
20d	4	8	0.162	11/32	40	S20ABN1	S20ABN5	S20ABNB

Exterior Nails

Cedar and Redwood Decking Nail

Features:

- Smaller compact heads are less visible
- Checker pattern on heads blends with wood grain and reduces glare from sunlight
- Annular ring shank increases pull-out resistance to help prevent nail heads from popping up over time.
- Slender shank permits nailing at board ends with reduced splitting
- Diamond point for easier driving
- Available in 3 colors: Gray, Redwood and Tan
- Choose Type 316 stainless steel for seaside applications and superior corrosion resistance
- Hammer caps recommended for painted-head nails

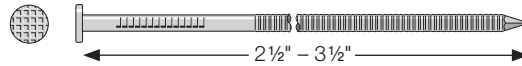

Type 316 Stainless Steel

Penny Size	Length (in.)	Gauge	Shank Diameter (in.)	Head Diameter (in.)	Color	Approx. Count per lb.	1 lb. Model No.	5 lb. Model No.	25 lb. Bucket Model No.
8d	2½	12	0.113	7/32	Non-Painted	145	T8CRD1	T8CRD5	T8CRDB
8d	2½	12	0.113	7/32	Gray	145	T8CRDG1	T8CRDG5	T8CRDGB
8d	2½	12	0.113	7/32	Redwood	145	T8CRDR1	T8CRDR5	T8CRDRB
8d	2½	12	0.113	7/32	Tan	145	T8CRDT1	T8CRDT5	T8CRDTB
10d	3	12	0.113	7/32	Non-Painted	120	T10CRD1	T10CRD5	T10CRDB
10d	3	12	0.113	7/32	Gray	120	T10CRDG1	T10CRDG5	T10CRDGB
10d	3	12	0.113	7/32	Redwood	120	T10CRDR1	T10CRDR5	T10CRDRB
10d	3	12	0.113	7/32	Tan	120	T10CRDT1	T10CRDT5	T10CRDTB
12d	3¼	12	0.113	7/32	Non-Painted	110	T12CRD1	T12CRD5	T12CRDB
12d	3¼	12	0.113	7/32	Gray	110	T12CRDG1	T12CRDG5	T12CRDGB
12d	3¼	12	0.113	7/32	Redwood	110	T12CRDR1	T12CRDR5	T12CRDRB
12d	3¼	12	0.113	7/32	Tan	110	T12CRDT1	T12CRDT5	T12CRDTB
16d	3½	11	0.120	¼	Non-Painted	88	T16CRD1	T16CRD5	T16CRDB
16d	3½	11	0.120	¼	Gray	88	T16CRDG1	T16CRDG5	T16CRDGB
16d	3½	11	0.120	¼	Redwood	88	T16CRDR1	T16CRDR5	T16CRDRB
16d	3½	11	0.120	¼	Tan	88	T16CRDT1	T16CRDT5	T16CRDTB



Type 304 Stainless Steel

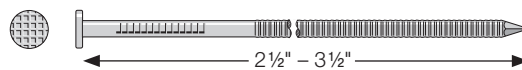

Penny Size	Length (in.)	Gauge	Shank Diameter (in.)	Head Diameter (in.)	Color	Approx. Count per lb.	1 lb. Model No.	5 lb. Model No.	25 lb. Bucket Model No.
8d	2½	12	0.113	7/32	Non-Painted	145	S8CRD1	S8CRD5	S8CRDB
8d	2½	12	0.113	7/32	Gray	145	S8CRDG1	S8CRDG5	S8CRDGB
8d	2½	12	0.113	7/32	Redwood	145	S8CRDR1	S8CRDR5	S8CRDRB
8d	2½	12	0.113	7/32	Tan	145	S8CRDT1	S8CRDT5	S8CRDTB
10d	3	12	0.113	7/32	Non-Painted	120	S10CRD1	S10CRD5	S10CRDB
10d	3	12	0.113	7/32	Gray	120	S10CRDG1	S10CRDG5	S10CRDGB
10d	3	12	0.113	7/32	Redwood	120	S10CRDR1	S10CRDR5	S10CRDRB
10d	3	12	0.113	7/32	Tan	120	S10CRDT1	S10CRDT5	S10CRDTB
12d	3¼	12	0.113	7/32	Non-Painted	110	S12CRD1	S12CRD5	S12CRDB
12d	3¼	12	0.113	7/32	Gray	110	S12CRDG1	S12CRDG5	S12CRDGB
12d	3¼	12	0.113	7/32	Redwood	110	S12CRDR1	S12CRDR5	S12CRDRB
12d	3¼	12	0.113	7/32	Tan	110	S12CRDT1	S12CRDT5	S12CRDTB
16d	3½	11	0.120	¼	Non-Painted	88	S16CRD1	S16CRD5	S16CRDB
16d	3½	11	0.120	¼	Gray	88	S16CRDG1	S16CRDG5	S16CRDGB
16d	3½	11	0.120	¼	Redwood	88	S16CRDR1	S16CRDR5	S16CRDRB
16d	3½	11	0.120	¼	Tan	88	S16CRDT1	S16CRDT5	S16CRDTB



Exterior Nails

Wood Siding Nail

Features:

- Checker pattern on heads blends with wood grain, reduces glare from sunlight and accepts surface finishes
- Annular ring shank increases pull-out resistance to provide a secure attachment that reduces cupping of siding boards
- Diamond point for easier driving
- Choose Type 316 stainless steel for seaside applications and superior corrosion resistance

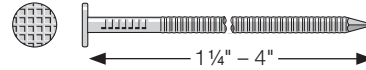

Type 316 Stainless Steel

Penny Size	Length (in.)	Gauge	Shank Diameter (in.)	Head Diameter (in.)	Approx. Count per lb.	1 lb. Model No.	5 lb. Model No.	25 lb. Bucket Model No.
3d	1¼	14	0.083	5/32	495	T3SND1	T3SND5	T3SNDB
4d	1½	14	0.083	5/32	398	T4SND1	T4SND5	T4SNDB
5d	1¾	14	0.083	5/32	354	T5SND1	T5SND5	T5SNDB
6d	2	13	0.092	5/32	245	T6SND1	T6SND5	T6SNDB
7d	2¼	13	0.092	5/32	215	T7SND1	T7SND5	T7SNDB
8d	2½	13	0.092	5/32	196	T8SND1	T8SND5	T8SNDB
10d	3	12	0.113	7/32	120	T10SND1	T10SND5	T10SNDB
12d	3¼	12	0.113	7/32	110	T12SND1	T12SND5	T12SNDB
16d	3½	11	0.120	¼	88	T16SND1	T16SND5	T16SNDB
20d	4	10	0.131	¼	74	T20SND1	T20SND5	T20SNDB

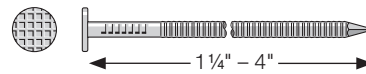

Type 304 Stainless Steel

Penny Size	Length (in.)	Gauge	Shank Diameter (in.)	Head Diameter (in.)	Approx. Count per lb.	1 lb. Model No.	5 lb. Model No.	25 lb. Bucket Model No.
3d	1¼	14	0.083	5/32	495	S3SND1	S3SND5	S3SNDB
5d	1¾	13	0.092	5/32	260	SP5SND1	SP5SND5	SP5SNDB
4d	1½	14	0.083	5/32	398	S4SND1	S4SND5	S4SNDB
5d	1¾	14	0.083	5/32	354	S5SND1	S5SND5	S5SNDB
6d	2	13	0.092	5/32	245	S6SND1	S6SND5	S6SNDB
7d	2¼	13	0.092	5/32	215	S7SND1	S7SND5	S7SNDB
8d	2½	13	0.092	5/32	196	S8SND1	S8SND5	S8SNDB
10d	3	12	0.113	7/32	120	S10SND1	S10SND5	S10SNDB
12d	3¼	12	0.113	7/32	110	S12SND1	S12SND5	S12SNDB
16d	3½	11	0.120	¼	88	S16SND1	S16SND5	S16SNDB
20d	4	10	0.131	¼	74	S20SND1	S20SND5	S20SNDB

Cedar Trim Nail

Features:

- Designed to fashion woven corners
- Ultra-thin .072" wire diameter
- Unobtrusive .135" diameter head
- Minimized splitting of shingles with its blunt diamond point
- Annular thread
- Choose Type 316 stainless steel for seaside applications and superior corrosion resistance



Type 316 Stainless Steel

Penny Size	Length (in.)	Wire Gauge	Shank Diameter (in.)	Head Diameter (in.)	Approx. Count per lb.	1 lb. Model No.	5 lb. Model No.
3d	1¼	15	0.072	9/64	550	T3ACDRWVR1	T3ACDRWVR5

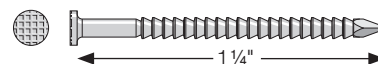

Type 304 Stainless Steel

Penny Size	Length (in.)	Wire Gauge	Shank Diameter (in.)	Head Diameter (in.)	Approx. Count per lb.	1 lb. Model No.	5 lb. Model No.
3d	1¼	15	0.072	9/64	550	S3ACDRWVR1	S3ACDRWVR5

Exterior Nails

Common Nail – Annular Ring Shank

Features:

- Annular ring shank increases withdrawal resistance to provide a secure attachment
- Stainless-steel nails are recommended for construction of permanent wood foundations by the *ANSI/AF&PA Permanent Wood Foundations Design Specifications*
- Choose Type 316 stainless steel for seaside applications and superior corrosion resistance
- **Special Order Options** – Call Simpson Strong-Tie for details (800) 999-5099
 - Spiral shank
 - Silicon-bronze nails

Type 316 Stainless Steel

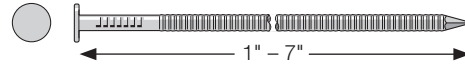

Penny Size	Length (in.)	Gauge	Shank Diameter (in.)	Head Diameter (in.)	Approx. Count per lb.	1 lb. Model No.	5 lb. Model No.	25 lb. Bucket Model No.
2d	1	15	0.072	3/16	807	T2ACN1	T2ACN5	T2ACNB
3d	1 1/4	14	0.083	7/32	473	T3ACN1	T3ACN5	T3ACNB
4d	1 1/2	12	0.113	1/4	228	T4ACN1	T4ACN5	T4ACNB
4d	1 1/2	9	0.148	5/16	130	T4HACN1	T4HACN5	T4HACNB
5d	1 3/4	12	0.113	1/4	193	T5ACN1	T5ACN5	T5ACNB
6d	2	11	0.120	17/64	144	T6ACN1	T6ACN5	T6ACNB
7d	2 1/4	11	0.120	17/64	133	T7ACN1	T7ACN5	T7ACNB
8d	2 1/2	10	0.131	9/32	94	T8ACN1	T8ACN5	T8ACNB
10d	3	9	0.148	5/16	67	T10ACN1	T10ACN5	T10ACNB
12d	3 1/4	9	0.148	5/16	60	T12ACN1	T12ACN5	T12ACNB
16d	3 1/2	8	0.162	11/32	44	T16ACN1	T16ACN5	T16ACNB
20d	4	6	0.203	7/16	25	T20ACN1	T20ACN5	T20ACNB
30d	4 1/2	6	0.203	7/16	22	T30ACN1	T30ACN5	T30ACNB
40d	5	6	0.203	7/16	19	T40ACN1	T40ACN5	T40ACNB
60d	6	4	0.238	15/32	12	T60ACN1	T60ACN5	T60ACNB
70d	7	4	0.238	15/32	10	T70ACN1	T70ACN5	T70ACNB

Type 304 Stainless Steel



Penny Size	Length (in.)	Gauge	Shank Diameter (in.)	Head Diameter (in.)	Approx. Count per lb.	1 lb. Model No.	5 lb. Model No.	25 lb. Bucket Model No.
2d	1	15	0.072	3/16	807	S2ACN1	S2ACN5	S2ACNB
2d	1	14	0.083	7/32	530	S2HACN1	S2HACN5	S2HACNB
3d	1 1/4	14	0.083	7/32	473	S3ACN1	S3ACN5	S3ACNB
4d	1 1/2	12	0.113	1/4	228	S4ACN1	S4ACN5	S4ACNB
5d	1 3/4	12	0.113	1/4	193	S5ACN1	S5ACN5	S5ACNB
6d	2	11	0.120	17/64	144	S6ACN1	S6ACN5	S6ACNB
7d	2 1/4	11	0.120	17/64	133	S7ACN1	S7ACN5	S7ACNB
8d	2 1/2	10	0.131	9/32	94	S8ACN1	S8ACN5	S8ACNB
10d	3	9	0.148	5/16	67	S10ACN1	S10ACN5	S10ACNB
12d	3 1/4	9	0.148	5/16	60	S12ACN1	S12ACN5	S12ACNB
16d	3 1/2	8	0.162	11/32	44	S16ACN1	S16ACN5	S16ACNB
20d	4	6	0.203	7/16	25	S20ACN1	S20ACN5	S20ACNB
30d	4 1/2	6	0.203	7/16	22	S30ACN1	S30ACN5	S30ACNB
40d	5	6	0.203	7/16	19	S40ACN1	S40ACN5	S40ACNB
60d	6	4	0.238	15/32	12	S60ACN1	S60ACN5	S60ACNB
70d	7	4	0.238	15/32	10	S70ACN1	S70ACN5	S70ACNB

Exterior Nails

Common Nail – Smooth Shank

Features:

- Stainless-steel nails are recommended for construction of permanent wood foundations by the *ANSI/AF&PA Permanent Wood Foundations Design Specifications*
- Choose Type 316 stainless steel for seaside applications and superior corrosion resistance
- Special Order Options** – Call Simpson Strong-Tie for details (800) 999-5099
 - Spiral shank
 - Silicon-bronze nails

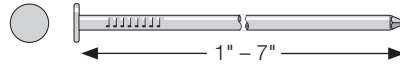

Type 316 Stainless Steel

Penny Size	Length (in.)	Gauge	Shank Diameter (in.)	Head Diameter (in.)	Approx. Count per lb.	1 lb. Model No.	5 lb. Model No.	25 lb. Bucket Model No.
2d	1	15	0.072	3/16	807	T2CN1	T2CN5	T2CNB
3d	1¼	14	0.083	7/32	473	T3CN1	T3CN5	T3CNB
4d	1½	12	0.113	¼	228	T4CN1	T4CN5	T4CNB
5d	1¾	12	0.113	¼	193	T5CN1	T5CN5	T5CNB
6d	2	11	0.120	17/64	144	T6CN1	T6CN5	T6CNB
7d	2¼	11	0.120	17/64	133	T7CN1	T7CN5	T7CNB
8d	2½	10	0.131	9/32	94	T8CN1	T8CN5	T8CNB
10d	3	9	0.148	5/16	67	T10CN1	T10CN5	T10CNB
12d	3¼	9	0.148	5/16	60	T12CN1	T12CN5	T12CNB
16d	3½	8	0.162	11/32	44	T16CN1	T16CN5	T16CNB
20d	4	6	0.203	7/16	25	T20CN1	T20CN5	T20CNB
30d	4½	6	0.203	7/16	22	T30CN1	T30CN5	T30CNB
40d	5	6	0.203	7/16	19	T40CN1	T40CN5	T40CNB
60d	6	4	0.238	15/32	12	T60CN1	T60CN5	T60CNB
70d	7	4	0.238	15/32	10	T70CN1	T70CN5	T70CNB

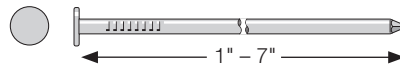

Type 304 Stainless Steel

Penny Size	Length (in.)	Gauge	Shank Diameter (in.)	Head Diameter (in.)	Approx. Count per lb.	1 lb. Model No.	5 lb. Model No.	25 lb. Bucket Model No.
2d	1	15	0.072	3/16	807	S2CN1	S2CN5	S2CNB
3d	1¼	14	0.083	7/32	473	S3CN1	S3CN5	S3CNB
4d	1½	12	0.113	¼	228	S4CN1	S4CN5	S4CNB
4d	1½	9	0.148	5/16	130	S4HCN1	S4HCN5	S4HCNB
5d	1¾	12	0.113	¼	193	S5CN1	S5CN5	S5CNB
6d	2	11	0.120	17/64	144	S6CN1	S6CN5	S6CNB
7d	2¼	11	0.120	17/64	133	S7CN1	S7CN5	S7CNB
8d	2½	10	0.131	9/32	94	S8CN1	S8CN5	S8CNB
10d	3	9	0.148	5/16	67	S10CN1	S10CN5	S10CNB
12d	3¼	9	0.148	5/16	60	S12CN1	S12CN5	S12CNB
16d	3½	8	0.162	11/32	44	S16CN1	S16CN5	S16CNB
20d	4	6	0.203	7/16	25	S20CN1	S20CN5	S20CNB
30d	4½	6	0.203	7/16	22	S30CN1	S30CN5	S30CNB
40d	5	6	0.203	7/16	19	S40CN1	S40CN5	S40CNB
60d	6	4	0.238	15/32	12	S60CN1	S60CN5	S60CNB
70d	7	4	0.238	15/32	10	S70CN1	S70CN5	S70CNB

Exterior Nails

Fencing Nail

Features:

- Checker pattern on heads blends with wood grain, reduces glare from sunlight and accepts surface finishes
- Annular ring shank increases withdrawal resistance to provide a secure attachment
- Diamond point for easier driving
- Choose Type 316 stainless steel for seaside applications to resist streaking on wood or vinyl fences

Type 316 Stainless Steel

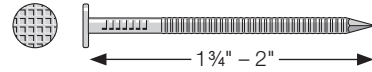

Penny Size	Length (in.)	Gauge	Shank Diameter (in.)	Head Diameter (in.)	Approx. Count per lb.	1 lb. Model No.	5 lb. Model No.	25 lb. Bucket Model No.
5d	1 $\frac{3}{4}$	12	0.113	$\frac{15}{64}$	193	T5FNX1	T5FNX5	T5FNXB
6d	2	12	0.113	$\frac{15}{64}$	175	T6FNX1	T6FNX5	T6FNXB

Type 304 Stainless Steel

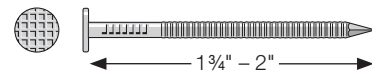

Penny Size	Length (in.)	Gauge	Shank Diameter (in.)	Head Diameter (in.)	Approx. Count per lb.	1 lb. Model No.	5 lb. Model No.	25 lb. Bucket Model No.
5d	1 $\frac{3}{4}$	12	0.113	$\frac{15}{64}$	193	S5FNX1	S5FNX5	S5FNXB
6d	2	12	0.113	$\frac{15}{64}$	175	S6FNX1	S6FNX5	S6FNXB

Fiber-Cement Siding Nail

Features:

- Designed expressly for application of various lap and panel siding materials made of fiber-cement composites
- Checker pattern on heads blends with faux wood grain, reduces glare from sunlight and accepts surface finishes
- Annular ring shank increases withdrawal resistance to provide a secure attachment
- 1 $\frac{1}{4}$ " length has an $\frac{11}{32}$ " head for blind-nailing lap siding
- Diamond point for easier driving
- Recommended for seaside applications and superior corrosion resistance

Type 316 Stainless Steel

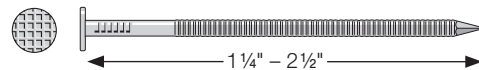

Penny Size	Length (in.)	Gauge	Shank Diameter (in.)	Head Diameter (in.)	Approx. Count per lb.	1 lb. Model No.	5 lb. Model No.	25 lb. Bucket Model No.
3d	1 $\frac{1}{4}$	11	0.120	$\frac{11}{32}$	199	T3PCS1	T3PCS5	T3PCSB
4d	1 $\frac{1}{2}$	11	0.120	$\frac{9}{32}$	179	T4PCS1	T4PCS5	T4PCSB
6d	2	11	0.120	$\frac{9}{32}$	144	T6PCS1	T6PCS5	T6PCSB
8d	2 $\frac{1}{2}$	11	0.120	$\frac{9}{32}$	115	T8PCS1	T8PCS5	T8PCSB

Exterior Nails

Finishing Nail

Features:

- Brad head for a less-visible appearance
- Smooth shank, diamond point for easier driving
- Choose Type 316 stainless steel for seaside applications and superior corrosion resistance

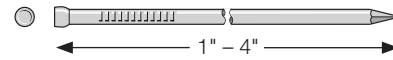

Type 316 Stainless Steel

Penny Size	Length (in.)	Gauge	Shank Diameter (in.)	Head Diameter (in.)	Approx. Count per lb.	1 lb. Model No.	5 lb. Model No.	25 lb. Bucket Model No.
2d	1	15	0.072	0.109	863	T2FN1*	T2FN5*	T2FNB*
3d	1¼	15	0.072	0.109	649	T3FN1*	T3FN5*	T3FNB*
4d	1½	14	0.083	0.120	434	T4FN1	T4FN5	T4FNB
5d	1¾	14	0.083	0.120	375	T5FN1*	T5FN5*	T5FNB*
6d	2	13	0.092	0.135	247	T6FN1	T6FN5	T6FNB
8d	2½	12	0.113	0.148	146	T8FN1	T8FN5	T8FNB
10d	3	11	0.120	0.165	102	T10FN1	T10FN5	T10FNB
12d	3¼	11	0.120	0.165	97	T12FN1*	T12FN5*	T12FNB*
16d	3½	11	0.120	0.165	86	T16FN1	T16FN5	T16FNB
20d	4	11	0.120	0.201	85	T20FN1*	T20FN5*	T20FNB*

*These nails are special-order, non-stock items and are subject to minimum order quantities and longer lead times. Call Simpson Strong-Tie for details (800) 999-5099.

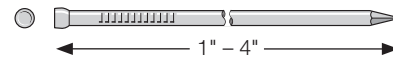

Type 304 Stainless Steel

Penny Size	Length (in.)	Gauge	Shank Diameter (in.)	Head Diameter (in.)	Approx. Count per lb.	1 lb. Model No.	5 lb. Model No.	25 lb. Bucket Model No.
2d	1	15	0.072	0.109	863	S2FN1*	S2FN5*	S2FNB*
3d	1¼	15	0.072	0.109	649	S3FN1*	S3FN5*	S3FNB*
4d	1½	14	0.083	0.120	434	S4FN1	S4FN5	S4FNB
5d	1¾	14	0.083	0.120	375	S5FN1*	S5FN5*	S5FNB*
6d	2	13	0.092	0.135	247	S6FN1	S6FN5	S6FNB
8d	2½	12	0.113	0.148	146	S8FN1	S8FN5	S8FNB
10d	3	11	0.120	0.165	102	S10FN1	S10FN5	S10FNB
12d	3¼	11	0.120	0.165	97	S12FN1*	S12FN5*	S12FNB*
16d	3½	11	0.120	0.165	86	S16FN1	S16FN5	S16FNB
20d	4	11	0.120	0.201	85	S20FN1*	S20FN5*	S20FNB*

*These nails are special-order, non-stock items and are subject to minimum order quantities and longer lead times. Call Simpson Strong-Tie for details (800) 999-5099.

Exterior Nails

Nail with EPDM Washer – Annular Ring Shank

Features:

- Smooth head
- Washers are made from Types 316 and 304 stainless steel respectively with bonded EPDM washer to provide a weather-resistant seal for exterior sheathing and roofing applications
- Annular ring shanks increase withdrawal resistance to provide a secure attachment
- For information on purchasing washers separately see page 119

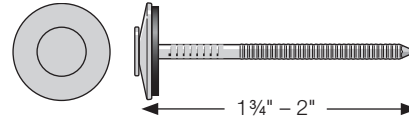

Type 316 Stainless Steel

Penny Size	Length (in.)	Gauge	Shank Diameter (in.)	Washer Diameter (in.)	Model No.	
					100 count	1000 count
5d	1 3/4	10	0.131	0.625	T10A175X0C	T10A175X0M
6d	2	10	0.131	0.625	T10A200X0C	T10A200X07

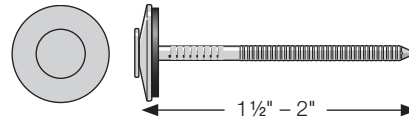

Type 304 Stainless Steel

Penny Size	Length (in.)	Gauge	Shank Diameter (in.)	Washer Diameter (in.)	Model No.	
					100 count	1000 count
4d	1 1/2	10	0.131	0.625	S10A150X0C	S10A150X0M
5d	1 3/4	10	0.131	0.625	S10A175X0C	S10A175X0M
5d	1 3/4	11	0.120	0.625	S11A175X0C	S11A175X0M
6d	2	10	0.131	0.625	S10A200X0C	S10A200X0M

Nail with EPDM Washer – Spiral Shank

Features:

- Smooth head
- Washers are made from Types 316 and 304 stainless steel with bonded EPDM washer to provide a weather-resistant seal for exterior sheathing and roofing applications
- Spiral shanks increase withdrawal resistance to provide a secure attachment
- For information on purchasing washers separately see page 119

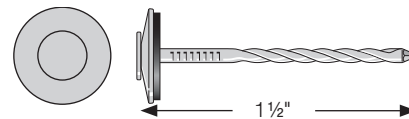

Type 304 Stainless Steel

Penny Size	Length (in.)	Gauge	Shank Diameter (in.)	Washer Diameter (in.)	Model No.	
					100 count	1000 count
4d	1 1/2	10	0.131	0.625	S10S150X0C	S10S150X0M

Exterior Nails

Post and Beam Nail – Annular Ring Shank

Features:

- Checker pattern on heads blends with wood grain, reduces glare from sunlight and accepts surface finishes
- Annular ring shank increases withdrawal resistance to provide a secure attachment
- Stainless-steel nails are recommended for construction of permanent wood foundations by the *ANSI/AF&PA Permanent Wood Foundations Design Specifications*
- Choose Type 316 stainless steel for seaside applications and superior corrosion resistance
- **Special Order Options** – Call Simpson Strong-Tie for details (800) 999-5099
 - Spiral shank
 - Silicon-bronze nails

Type 316 Stainless Steel

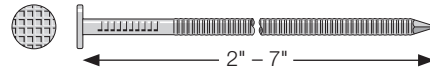

Penny Size	Length (in.)	Gauge	Shank Diameter (in.)	Head Diameter (in.)	Approx. Count per lb.	1 lb. Model No.	5 lb. Model No.	25 lb. Bucket Model No.
6d	2	12	0.113	17/64	175	T6APB1	T6APB5	T6APBB
8d	2½	11	0.120	17/64	115	T8APB1	T8APB5	T8APBB
10d	3	10	0.131	9/32	79	T10APB1	T10APB5	T10APBB
12d	3¼	10	0.131	9/32	72	T12APB1	T12APB5	T12APBB
16d	3½	9	0.148	5/16	56	T16APB1	T16APB5	T16APBB
40d	5	8	0.162	11/32	31	T40APB1	T40APB5	T40APBB
60d	6	6	0.203	7/16	17	T60APB1	T60APB5	T60APBB
70d	7	4	0.238	15/32	10	T70APB1	T70APB5	T70APBB

Type 304 Stainless Steel

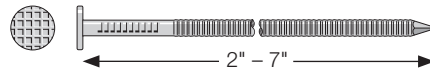

Penny Size	Length (in.)	Gauge	Shank Diameter (in.)	Head Diameter (in.)	Approx. Count per lb.	1 lb. Model No.	5 lb. Model No.	25 lb. Bucket Model No.
6d	2	12	0.113	17/64	175	S6APB1	S6APB5	S6APBB
8d	2½	11	0.120	17/64	115	S8APB1	S8APB5	S8APBB
10d	3	10	0.131	9/32	79	S10APB1	S10APB5	S10APBB
12d	3¼	10	0.131	9/32	72	S12APB1	S12APB5	S12APBB
16d	3½	9	0.148	5/16	56	S16APB1	S16APB5	S16APBB
20d	4	8	0.162	11/32	40	S20APB1	S20APB5	S20APBB
30d	4½	8	0.162	11/32	35	S30APB1	S30APB5	S30APBB
40d	5	8	0.162	11/32	31	S40APB1	S40APB5	S40APBB
60d	6	6	0.203	7/16	17	S60APB1	S60APB5	S60APBB
70d	7	4	0.238	15/32	10	S70APB1	S70APB5	S70APBB

Exterior Nails

Preservative-Treated Wood Decking Nail

Features:

- Ideal for decks and docks
- Checker pattern on heads blends with wood grain and reduces glare from sunlight
- Annular ring shank increases withdrawal resistance to help prevent nail heads from popping up over time
- Larger shank diameter easily penetrates both green and seasoned preservative-treated pine
- Diamond point for easier driving
- Choose Type 316 stainless steel for seaside applications and superior corrosion resistance

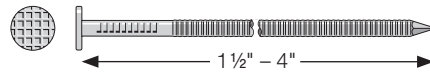

Type 316 Stainless Steel

Penny Size	Length (in.)	Gauge	Shank Diameter (in.)	Head Diameter (in.)	Approx Count per lb.	1 lb. Model No.	5 lb. Model No.	25 lb. Bucket Model No.
4d	1½	12	0.113	¼	228	T4PTD1	T4PTD5	T4PTDB
6d	2	11	0.120	⅜	144	T6PTD1	T6PTD5	T6PTDB
8d	2½	11	0.120	⅜	115	T8PTD1	T8PTD5	T8PTDB
8d	2½	10	0.131	⅜	94	T8HPTD1	T8HPTD5	T8HPTDB
10d	3	10	0.131	⅜	79	T10PTD1	T10PTD5	T10PTDB
10d	3	9	0.148	⅝	67	T10HPTD1	T10HPTD5	T10HPTDB
12d	3¼	9	0.148	⅝	60	T12PTD1	T12PTD5	T12PTDB
16d	3½	9	0.148	⅝	56	T16PTD1	T16PTD5	T16PTDB
16d	3½	8	0.162	1½	44	T16HPTD1	T16HPTD5	T16HPTDB
20d	4	8	0.162	1½	40	T20PTD1	T20PTD5	T20PTDB
20d	4	6	0.203	7⁄16	25	—	T20HPTD5	T20HPTDB

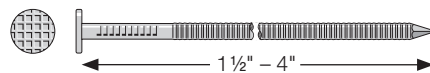

Type 304 Stainless Steel

Penny Size	Length (in.)	Gauge	Shank Diameter (in.)	Head Diameter (in.)	Approx Count per lb.	1 lb. Model No.	5 lb. Model No.	25 lb. Bucket Model No.
4d	1½	12	0.113	¼	228	S4PTD1	S4PTD5	S4PTDB
6d	2	11	0.120	⅜	144	S6PTD1	S6PTD5	S6PTDB
8d	2½	11	0.120	⅜	115	S8PTD1	S8PTD5	S8PTDB
8d	2½	10	0.131	⅜	94	S8HPTD1	S8HPTD5	S8HPTDB
10d	3	10	0.131	⅜	79	S10PTD1	S10PTD5	S10PTDB
10d	3	9	0.148	⅝	67	S10HPTD1	S10HPTD5	S10HPTDB
12d	3¼	9	0.148	⅝	60	S12PTD1	S12PTD5	S12PTDB
16d	3½	9	0.148	⅝	56	S16PTD1	S16PTD5	S16PTDB
16d	3½	8	0.162	1½	44	S16HPTD1	S16HPTD5	S16HPTDB
20d	4	8	0.162	1½	40	S20PTD1	S20PTD5	S20PTDB
20d	4	6	0.203	7⁄16	25	S20HPTD1	S20HPTD5	S20HPTDB

Exterior Nails

Pyramid-Head Nail

Features:

- “Pyramid” style decorative heads are reminiscent of old rose-head nails and lend a rustic look to face-nailed lap, bevel and board and batten siding jobs
- Annular ring shank increases withdrawal resistance to provide a secure attachment
- Silicon bronze weathers to dark brown color
- These nails are special-order, non-stock items and are subject to minimum order quantities and longer lead times. Please call Simpson Strong-Tie for details (800) 999-5099.

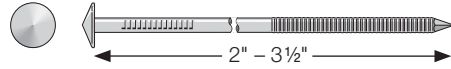

Type 316 Stainless Steel

Penny Size	Length (in.)	Gauge	Shank Diameter (in.)	Head Diameter (in.)	Approx. Count per lb.	1 lb. Model No.	5 lb. Model No.	25 lb. Bucket Model No.
6d	2	11	0.120	¼	144	T6PSN1	T6PSN5	T6PSNB
8d	2½	11	0.120	¼	115	T8PSN1	T8PSN5	T8PSNB
10d	3	11	0.120	¼	99	T10PSN1	T10PSN5	T10PSNB

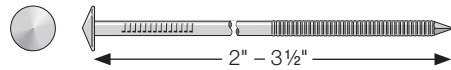

Silicon Bronze

Penny Size	Length (in.)	Gauge	Shank Diameter (in.)	Head Diameter (in.)	Approx. Count per lb.	1 lb. Model No.	5 lb. Model No.	25 lb. Bucket Model No.
6d	2	11	0.120	¼	144	I6PSN1	I6PSN5	I6PSNB
8d	2½	11	0.120	¼	115	I8PSN1	I8PSN5	I8PSNB
10d	3	11	0.120	¼	99	I10PSN1	I10PSN5	I10PSNB
16d	3½	11	0.120	¼	88	I16PSN1	I16PSN5	I16PSNB

Bevel Siding Installation Calculator

Nominal Width	Exposed Face (in.)	Overlap (in.)	Nail Count Factor Linear Foot	Nail Count Factor Square Foot
4	2½	1	0.75	3.60
6	4½	1	0.75	2.03
8	6½	1½	0.75	1.43
10	8½	1½	0.75	1.13
12	10½	1½	0.75	0.90

How To Figure:

Multiply the linear feet or square feet by the nail count factor. The result is the quantity of nails required.

- One (1) nail per stud – 16" on center
- Allowance for waste and loss should be added

Exterior Nails

Painted Siding Nail

Features:

- Premium-quality nails for cedar, redwood and cypress siding materials
- Durable painted finish helps heads blend with siding material
- Checker pattern on head blends with wood texture
- Annular ring shank increases withdrawal resistance to provide a secure attachment that reduces cupping of siding boards
- Slender gauge and diamond point for easier driving
- Custom colors available upon request (minimums apply) – call for details
- Choose Type 316 stainless steel for seaside applications and superior corrosion resistance
- Hammer caps recommended for painted head nails
- These nails are special-order, non-stock items and are subject to minimum order quantities and longer lead times. Please call Simpson Strong-Tie for details (800) 999-5099.



Type 316 Stainless Steel

Penny Size	Length (in.)	Gauge	Shank Diameter (in.)	Head Diameter (in.)	Color	Approx. Count per lb.	1 lb. Model No.	5 lb. Model No.	25 lb. Bucket Model No.
6d	2	13	0.092	5/32	Dark Brown	245	T6SNDB1	T6SNDB5	T6SNDBB
6d	2	13	0.092	5/32	Gray	245	T6SNDG1	T6SNDG5	T6SNDGB
6d	2	13	0.092	5/32	Redwood	245	T6SNDR1	T6SNDR5	T6SNDRB
6d	2	13	0.092	5/32	Sienna	245	T6SND S1	T6SND S5	T6SND SB
6d	2	13	0.092	5/32	Tan	245	T6SND T1	T6SND T5	T6SND TB
6d	2	13	0.092	5/32	White	245	T6SND W1	T6SND W5	T6SND WB
8d	2½	13	0.092	5/32	Dark Brown	196	T8SNDB1	T8SNDB5	T8SNDBB
8d	2½	13	0.092	5/32	Gray	196	T8SNDG1	T8SNDG5	T8SNDGB
8d	2½	13	0.092	5/32	Redwood	196	T8SNDR1	T8SNDR5	T8SNDRB
8d	2½	13	0.092	5/32	Tan	196	T8SND T1	T8SND T5	T8SND TB
8d	2½	13	0.092	5/32	White	196	T8SND W1	T8SND W5	T8SND WB
10d	3	12	0.113	7/32	Dark Brown	120	T10SNDB1	T10SNDB5	T10SNDBB
10d	3	12	0.113	7/32	Gray	120	T10SNDG1	T10SNDG5	T10SNDGB
10d	3	12	0.113	7/32	Redwood	120	T10SNDR1	T10SNDR5	T10SNDRB
10d	3	12	0.113	7/32	Tan	120	T10SND T1	T10SND T5	T10SND TB
10d	3	12	0.113	7/32	White	120	T10SND W1	T10SND W5	T10SND WB



Screws and Nails

Exterior Nails

Painted Siding Nail (cont.)

These nails are special-order, non-stock items and are subject to minimum order quantities and longer lead times. Please call Simpson Strong-Tie for details (800) 999-5099.

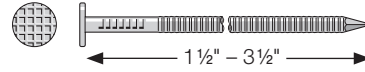

Type 304 Stainless Steel

Penny Size	Length (in.)	Gauge	Shank Diameter (in.)	Head Diameter (in.)	Color	Approx. Count per lb.	1 lb. Model No.	5 lb. Model No.	25 lb. Bucket Model No.
4d	1½	14	0.083	5/32	Redwood	398	S4SNDR1	S4SNDR5	—
4d	1½	14	0.083	5/32	Tan	398	S4SNDT1	S4SNDT5	—
4d	1½	14	0.083	5/32	White	398	—	—	S4SNDWB
6d	2	13	0.092	5/32	Dark Brown	245	S6SNDB1	S6SNDB5	S6SNDBB
6d	2	13	0.092	5/32	Gray	245	S6SNDG1	S6SNDG5	S6SNDGB
6d	2	13	0.092	5/32	Redwood	245	S6SNDR1	S6SNDR5	S6SNDRB
6d	2	13	0.092	5/32	Sienna	245	S6SNDS1	S6SNDS5	S6SNDSB
6d	2	13	0.092	5/32	Tan	245	S6SNDT1	S6SNDT5	S6SNDTB
6d	2	13	0.092	5/32	White	245	S6SNDW1	S6SNDW5	S6SNDWB
8d	2½	13	0.092	5/32	Dark Brown	196	S8SNDB1	S8SNDB5	S8SNDBB
8d	2½	13	0.092	5/32	Gray	196	S8SNDG1	S8SNDG5	S8SNDGB
8d	2½	13	0.092	5/32	Redwood	196	S8SNDR1	S8SNDR5	S8SNDRB
8d	2½	13	0.092	5/32	Sienna	196	S8SNDS1	S8SNDS5	S8SNDSB
8d	2½	13	0.092	5/32	Tan	196	S8SNDT1	S8SNDT5	S8SNDTB
8d	2½	13	0.092	5/32	White	196	S8SNDW1	S8SNDW5	S8SNDWB
10d	3	12	0.113	7/32	Dark Brown	120	S10SNDB1	S10SNDB5	S10SNDBB
10d	3	12	0.113	7/32	Gray	120	S10SNDG1	S10SNDG5	S10SNDGB
10d	3	12	0.113	7/32	Redwood	120	S10SNDR1	S10SNDR5	S10SNDRB
10d	3	12	0.113	7/32	Tan	120	S10SNDT1	S10SNDT5	S10SNDTB
10d	3	12	0.113	7/32	White	120	S10SNDW1	S10SNDW5	S10SNDWB
16d	3½	11	0.120	¼	Dark Brown	88	S16SNDB1	S16SNDB5	S16SNDBB
16d	3½	11	0.120	¼	Gray	88	S16SNDG1	S16SNDG5	S16SNDGB
16d	3½	11	0.120	¼	Redwood	88	S16SNDR1	S16SNDR5	S16SNDRB
16d	3-½	11	0.120	¼	Sienna	88	S16SNDS1	S16SNDS5	S16SNDSB
16d	3½	11	0.120	¼	Tan	88	S16SNDT1	S16SNDT5	S16SNDTB



Exterior Nails

Shake and Shingle Siding/Roofing Nail

Features:

- $\frac{7}{32}$ " diameter flat head provides ample bearing surface to firmly secure shakes and shingles of all types
- Checker pattern on heads blends with wood grain, reduces glare from sunlight and accepts surface finishes
- Annular ring-shank increases withdrawal resistance to provide a secure attachment that helps reduce cupping of siding boards
- Slender shanks minimize splitting
- Diamond point for easier driving
- Choose Type 316 stainless steel for seaside applications and superior corrosion resistance

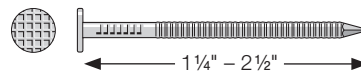

Type 316 Stainless Steel

Penny Size	Length (in.)	Gauge	Shank Diameter (in.)	Head Diameter (in.)	Approx. Count per lb.	1 lb. Model No.	5 lb. Model No.	25 lb. Bucket Model No.
3d	1 $\frac{1}{4}$	14	0.083	$\frac{7}{32}$	470	T3SN71	T3SN75	T3SN7B
4d	1 $\frac{1}{2}$	14	0.083	$\frac{7}{32}$	394	T4SN71	T4SN75	T4SN7B
5d	1 $\frac{3}{4}$	14	0.083	$\frac{7}{32}$	337	T5SN71	T5SN75	T5SN7B
6d	2	13	0.092	$\frac{7}{32}$	237	T6SN71	T6SN75	T6SN7B
7d	2 $\frac{1}{4}$	13	0.092	$\frac{7}{32}$	216	T7SN71	T7SN75	T7SN7B
8d	2 $\frac{1}{2}$	13	0.092	$\frac{7}{32}$	196	T8SN71	T8SN75	T8SN7B

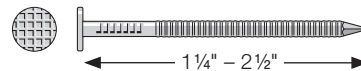

Type 304 Stainless Steel

Penny Size	Length (in.)	Gauge	Shank Diameter (in.)	Head Diameter (in.)	Approx. Count per lb.	1 lb. Model No.	5 lb. Model No.	25 lb. Bucket Model No.
3d	1 $\frac{1}{4}$	14	0.083	$\frac{7}{32}$	470	S3SN71	S3SN75	S3SN7B
4d	1 $\frac{1}{2}$	14	0.083	$\frac{7}{32}$	394	S4SN71	S4SN75	S4SN7B
5d	1 $\frac{3}{4}$	14	0.083	$\frac{7}{32}$	337	S5SN71	S5SN75	S5SN7B
6d	2	13	0.092	$\frac{7}{32}$	237	S6SN71	S6SN75	S6SN7B
7d	2 $\frac{1}{4}$	13	0.092	$\frac{7}{32}$	216	S7SN71	S7SN75	S7SN7B
8d	2 $\frac{1}{2}$	13	0.092	$\frac{7}{32}$	196	S8SN71	S8SN75	S8SN7B

Exterior Nails

Washed Roofing Nail

Features:

- Heavy EPDM washer provides a weather-proof seal ($\frac{9}{16}$ " O.D. x $\frac{1}{8}$ " thick)
- Recommended fastener for installation of corrugated-panel roofing as well as sheet-metal roofing and siding in corrosive environments
- Annular ring shank increases withdrawal resistance to provide a secure attachment to wood members.
- These nails are special-order, non-stock items and are subject to minimum order quantities and longer lead times. Please call Simpson Strong-Tie for details (800) 999-5099.

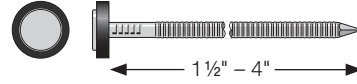

Type 304 Stainless Steel

Penny Size	Length (in.)	Gauge	Shank Diameter (in.)	Head Diameter (in.)	Approx. Count per lb.	5 lb. Model No.	25 lb. Bucket Model No.
4d	1½	10	0.131	$\frac{3}{8}$	113	S10150RNW5	S10150RNWB
5d	1¾	10	0.131	$\frac{3}{8}$	105	S10175RNW5	S10175RNWB
6d	2	10	0.131	$\frac{3}{8}$	98	S10200RNW5	S10200RNWB
8d	2½	10	0.131	$\frac{3}{8}$	83	S10250RNW5	S10250RNWB
10d	3	10	0.131	$\frac{3}{8}$	72	S10300RNW5	S10300RNWB

Exterior Nails

Roofing Nail – Annular Ring Shank

Features:

- Large, flat head provides extra bearing surface to firmly secure roofing material
- Annular ring shank increases withdrawal resistance to provide a secure attachment to wood members and plywood roof decks
- For slate roofs, determine the correct nail length by doubling the slate thickness and adding one inch
- Longer lengths ideal for installing curved Spanish roof tiles and thicker slate
- Aluminum nails also available with a screw shank; call Simpson Strong-Tie for details (800) 999-5099.

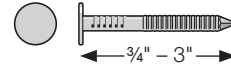

Type 316 Stainless Steel

Penny Size	Length (in.)	Gauge	Shank Diameter (in.)	Head Diameter (in.)	Approx. Count per lb.	1 lb. Model No.	5 lb. Model No.	25 lb. Bucket Model No.
—	3/4	10	0.131	3/8	281	T7510ARN1	T7510ARN5	T7510ARNB
2d	1	10	0.131	3/8	212	T210ARN1	T210ARN5	T210ARNB
3d	1 1/4	10	0.131	3/8	166	T310ARN1	T310ARN5	T310ARNB
3d	1 1/4	11	0.120	11/32	199	T311ARN1	T311ARN5	T311ARNB
4d	1 1/2	10	0.131	3/8	139	T410ARN1	T410ARN5	T410ARNB
4d	1 1/2	11	0.120	11/32	170	T411ARN1	T411ARN5	T411ARNB
5d	1 3/4	10	0.131	3/8	126	T510ARN1	T510ARN5	T510ARNB
5d	1 3/4	11	0.120	11/32	149	T511ARN1	T511ARN5	T511ARNB
6d	2	10	0.131	3/8	105	T610ARN1	T610ARN5	T610ARNB
6d	2	11	0.120	11/32	136	T611ARN1	T611ARN5	T611ARNB
8d	2 1/2	10	0.131	3/8	91	T810ARN1	T810ARN5	T810ARNB
10d	3	10	0.131	3/8	78	T1010ARN1	T1010ARN5	T1010ARNB

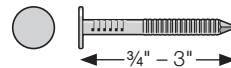

Type 304 Stainless Steel

Penny Size	Length (in.)	Gauge	Shank Diameter (in.)	Head Diameter (in.)	Approx. Count per lb.	1 lb. Model No.	5 lb. Model No.	25 lb. Bucket Model No.
—	3/4	10	0.131	3/8	281	S7510ARN1	S7510ARN5	S7510ARNB
2d	1	10	0.131	3/8	212	S210ARN1	S210ARN5	S210ARNB
3d	1 1/4	10	0.131	3/8	166	S310ARN1	S310ARN5	S310ARNB
3d	1 1/4	11	0.120	3/8	199	S311ARN1	S311ARN5	S311ARNB
4d	1 1/2	10	0.131	3/8	139	S410ARN1	S410ARN5	S410ARNB
4d	1 1/2	11	0.120	3/8	170	S411ARN1	S411ARN5	S411ARNB
5d	1 3/4	10	0.131	3/8	126	S510ARN1	S510ARN5	S510ARNB
5d	1 3/4	11	0.120	3/8	149	S511ARN1	S511ARN5	S511ARNB
6d	2	10	0.131	3/8	105	S610ARN1	S610ARN5	S610ARNB
6d	2	11	0.120	3/8	136	S611ARN1	S611ARN5	S611ARNB
8d	2 1/2	10	0.131	3/8	91	S810ARN1	S810ARN5	S810ARNB
10d	3	10	0.131	3/8	78	S1010ARN1	S1010ARN5	S1010ARNB

Exterior Nails

Roofing Nail – Annular Ring Shank (cont.)

Copper

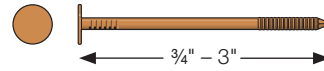

Penny Size	Length (in.)	Gauge	Shank Diameter (in.)	Head Diameter (in.)	Approx. Count per lb.	1 lb. Model No.	5 lb. Model No.	25 lb. Bucket Model No.
—	¾	11	0.120	¾	302	C7511ARN1	C7511ARN5	C7511ARNB
2d	1	10	0.131	7/16	187	C210ARN1	C210ARN5	C210ARNB
2d	1	11	0.120	¾	229	C211ARN1	C211ARN5	C211ARNB
3d	1¼	10	0.131	7/16	147	C310ARN1	C310ARN5	C310ARNB
3d	1¼	11	0.120	¾	187	C311ARN1	C311ARN5	C311ARNB
4d	1½	10	0.131	7/16	123	C410ARN1	C410ARN5	C410ARNB
4d	1½	11	0.120	¾	155	C411ARN1	C411ARN5	C411ARNB
5d	1¾	10	0.131	7/16	112	C510ARN1	C510ARN5	C510ARNB
5d	1¾	11	0.120	¾	139	C511ARN1	C511ARN5	C511ARNB
6d	2	10	0.131	7/16	93	C610ARN1	C610ARN5	C610ARNB
6d	2	11	0.120	¾	124	C611ARN1	C611ARN5	C611ARNB
8d	2½	10	0.131	7/16	81	C810ARN1	C810ARN5	C810ARNB
8d	2½	11	0.120	¾	108	C811ARN1	C811ARN5	C811ARNB
10d	3	10	0.131	7/16	67	C1010ARN1	C1010ARN5	C1010ARNB

Aluminum

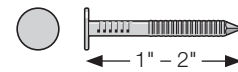

Penny Size	Length (in.)	Gauge	Shank Diameter (in.)	Head Diameter (in.)	Approx. Count per lb.	1 lb. Model No.	5 lb. Model No.	25 lb. Bucket Model No.
2d	1	11	0.120	¾	810	A211ARN1	A211ARN5	A211ARNB
3d	1¼	11	0.120	¾	686	A311ARN1	A311ARN5	A311ARNB
4d	1½	11	0.120	¾	577	A411ARN1	A411ARN5	A411ARNB
3d	1¼	9	0.148	7/16	440	A39ARN1	A39ARN5	A39ARNB
4d	1½	9	0.148	7/16	374	A49ARN1	A49ARN5	A49ARNB
6d	2	9	0.148	7/16	288	A69ARN1	A69ARN5	A69ARNB

These nails are special-order, non-stock items and are subject to minimum order quantities and longer lead times. Please call Simpson Strong-Tie for details (800) 999-5099.

Exterior Nails

Roofing Nail – Smooth Shank

Features:

- Large, flat head provides extra bearing surface to firmly secure roofing material
- For slate roofs, determine the correct nail length by doubling the slate thickness and adding one inch
- Longer lengths ideal for installing curved Spanish roof tiles and thicker slate
- Aluminum nails also available with a screw shank; call Simpson Strong-Tie for details (800) 999-5099.

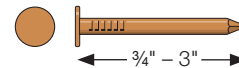

Copper

Penny Size	Length (in.)	Gauge	Shank Diameter (in.)	Head Diameter (in.)	Approx. Count per lb.	1 lb. Model No.	5 lb. Model No.	25 lb. Bucket Model No.
—	3/4	11	0.120	3/8	302	C7511RN1	C7511RN5	C7511RNB
2d	1	10	0.131	7/16	187	C210RN1	C210RN5	C210RNB
2d	1	11	0.120	3/8	229	C211RN1	C211RN5	C211RNB
3d	1 1/4	10	0.131	7/16	147	C310RN1	C310RN5	C310RNB
3d	1 1/4	11	0.120	3/8	187	C311RN1	C311RN5	C311RNB
4d	1 1/2	10	0.131	7/16	123	C410RN1	C410RN5	C410RNB
4d	1 1/2	11	0.120	3/8	155	C411RN1	C411RN5	C411RNB
5d	1 3/4	10	0.131	7/16	112	C510RN1	C510RN5	C510RNB
5d	1 3/4	11	0.120	3/8	139	C511RN1	C511RN5	C511RNB
6d	2	10	0.131	7/16	93	C610RN1	C610RN5	C610RNB
6d	2	11	0.120	3/8	124	C611RN1	C611RN5	C611RNB
8d	2 1/2	10	0.131	7/16	81	C810RN1	C810RN5	C810RNB
8d	2 1/2	11	0.120	3/8	108	C811RN1	C811RN5	C811RNB
10d	3	10	0.131	7/16	67	C1010RN1	C1010RN5	C1010RNB

Aluminum

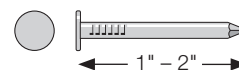

Penny Size	Length (in.)	Gauge	Shank Diameter (in.)	Head Diameter (in.)	Approx. Count per lb.	1 lb. Model No.	5 lb. Model No.	25 lb. Bucket Model No.
2d	1	11	0.120	3/8	810	A211RN1	A211RN5	A211RNB
3d	1 1/4	11	0.120	3/8	686	A311RN1	A311RN5	A311RNB
4d	1 1/2	11	0.120	3/8	577	A411RN1	A411RN5	A411RNB
3d	1 1/4	9	0.148	7/16	440	A39RN1	A39RN5	A39RNB
4d	1 1/2	9	0.148	7/16	374	A49RN1	A49RN5	A49RNB
6d	2	9	0.148	7/16	288	A69RN1	A69RN5	A69RNB

These nails are special-order, non-stock items and are subject to minimum order quantities and longer lead times. Please call Simpson Strong-Tie for details (800) 999-5099.

Exterior Nails

Tile/Slating Nail – Annular Ring Shank

Features:

- Large, flat head provides extra bearing surface to firmly secure roofing material
- Annular ring shank increases withdrawal resistance to provide a secure attachment to wood members and plywood roof decks
- For slate roofs, determine the correct nail length by doubling the slate thickness and adding one inch
- Longer lengths ideal for installing curved Spanish roof tiles and thicker slate
- Aluminum nails also available with a screw shank; call Simpson Strong-Tie for details.

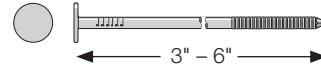

Type 304 Stainless Steel

Penny Size	Length (in.)	Gauge	Shank Diameter (in.)	Head Diameter (in.)	Approx. Count per lb.	5 lb. Model No.	25 lb. Bucket Model No.
10d	3	9	0.148	15/32	57	S10ATN5	S10ATNB
16d	3½	10	0.131	7/16	59	S16ATN5	S16ATNB
16d	3½	9	0.148	15/32	48	S16HATN5	S16HATNB
20d	4	9	0.148	15/32	43	S20ATN5	S20ATNB
40d	5	8	0.162	½	28	S40ATN5	S40ATNB
50d	5½	8	0.162	½	25	S50ATN5	S50ATNB
60d	6	8	0.162	½	23	S60ATN5	S60ATNB

These nails are special-order, non-stock items and are subject to minimum order quantities and longer lead times. Please call Simpson Strong-Tie for details (800) 999-5099.

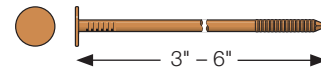

Copper

Penny Size	Length (in.)	Gauge	Shank Diameter (in.)	Head Diameter (in.)	Approx. Count per lb.	5 lb. Model No.	25 lb. Bucket Model No.
10d	3	9	0.148	15/32	57	C10ATN5	C10ATNB
16d	3½	10	0.131	7/16	59	C16ATN5	C16ATNB
16d	3½	9	0.148	15/32	48	C16HATN5	C16HATNB
20d	4	9	0.148	15/32	43	C20ATN5	C20ATNB
40d	5	8	0.162	½	28	C40ATN5	C40ATNB
50d	5½	8	0.162	½	25	C50ATN5	C50ATNB
60d	6	8	0.162	½	23	C60ATN5	C60ATNB

Exterior Nails

Tile/Slating Nail – Smooth Shank

Features:

- Large, flat head provides extra bearing surface to firmly secure roofing material
- For slate roofs, determine the correct nail length by doubling the slate thickness and adding one inch
- Longer lengths ideal for installing curved Spanish roof tiles and thicker slate
- Aluminum nails also available with a screw shank; call Simpson Strong-Tie for details.

Type 304 Stainless Steel

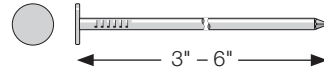

Penny Size	Length (in.)	Gauge	Shank Diameter (in.)	Head Diameter (in.)	Approx. Count per lb.	5 lb. Model No.	25 lb. Bucket Model No.
10d	3	9	0.148	15/32	57	S10TN5	S10TNB
16d	3½	10	0.131	7/16	59	S16TN5	S16TNB
16d	3½	9	0.148	15/32	48	S16HTN5	S16HTNB
20d	4	9	0.148	15/32	43	S20TN5	S20TNB
40d	5	8	0.162	½	28	S40TN5	S40TNB
50d	5½	8	0.162	½	25	S50TN5	S50TNB
60d	6	8	0.162	½	23	S60TN5	S60TNB

These nails are special-order, non-stock items and are subject to minimum order quantities and longer lead times. Please call Simpson Strong-Tie for details (800) 999-5099.

Copper

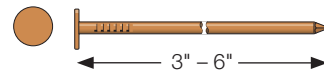

Penny Size	Length (in.)	Gauge	Shank Diameter (in.)	Head Diameter (in.)	Approx. Count per lb.	5 lb. Model No.	25 lb. Bucket Model No.
10d	3	9	0.148	15/32	57	C10TN5	C10TNB
16d	3½	10	0.131	7/16	59	C16TN5	C16TNB
16d	3½	9	0.148	15/32	48	C16HTN5	C16HTNB
20d	4	9	0.148	15/32	43	C20TN5	C20TNB
40d	5	8	0.162	½	28	C40TN5	C40TNB
50d	5½	8	0.162	½	25	C50TN5	C50TNB
60d	6	8	0.162	½	23	C60TN5	C60TNB

Specialty

Strong-Drive® SCNR RING-SHANK CONNECTOR Nail

For Simpson Strong-Tie® Connectors

SCNR ring-shank connector nails are the best choice for achieving maximum load values in connectors. Choose Type 316 stainless steel when using stainless steel connectors.

For Technical Data and Loads, see page 324

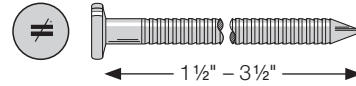

Type 316 Stainless Steel

Model No. Prefix	Length (in.)	Wire Gauge	Shank Diameter (in.)	Head Diameter (in.)	Approx. Count per lb.	1 lb. Model No.	5 lb. Model No.	25 lb. Bucket Model No.
SSNA8	1½	10	0.131	5/16	147	SSNA8D	SSNA8D5	SSNA8DB
SSA8D	2½	10	0.131	5/16	94	SSA8DD	SSA8D5	SSA8DB
SSNA10	1½	9	0.148	31/64	126	SSNA10D	SSNA10D5	SSNA10DB
SSA10D	3	9	0.148	31/64	66	SSA10DD	SSA10D5	SSA10DB
SSA16D	3½	8	0.162	3/8	44	SSA16DD	SSA16D5	SSA16DB

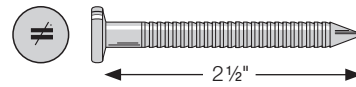

Hot-Dip Galvanized – Class D

Model No. Prefix	Length (in.)	Gauge	Shank Diameter (in.)	Head Diameter (in.)	Approx. Count per lb.	1 lb. Model No.	5 lb. Model No.	25 lb. Bucket Model No.
N4AHDG	2½	3½	0.250	½	27	N54AHDG – Sold by the pound		

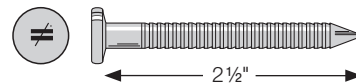

Bright

Model No. Prefix	Length (in.)	Gauge	Shank Diameter (in.)	Head Diameter (in.)	Approx. Count per lb.	1 lb. Model No.	5 lb. Model No.	25 lb. Bucket Model No.
N54A	2½	3½	0.250	½	27	N54A – Sold by the pound		

Bright nails are not for use in exterior or preservative-treated wood applications.

Specialty

Strong-Drive® SCN SMOOTH-SHANK CONNECTOR Nail

For Simpson Strong-Tie® Connectors

Simpson Strong-Tie Connector nails are the best choice for Simpson Strong-Tie connectors.

For Technical Data and Loads, see page 325

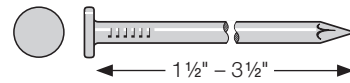

Hot-Dip Galvanized – Class D

Model No. Prefix	Length (in.)	Gauge	Shank Diameter (in.)	Head Diameter (in.)	Approx. Count per lb.	1 lb. Model No.	5 lb. Model No.
N8	1½	10	0.131	5/16	147	N8DHDG	N8D5HDG
N10	1½	9	0.148	5/16	120	N10DHDG	N10D5HDG
10D	3	9	0.148	5/16	50	10DHDG	10D5HDG
16D	3½	8	0.162	11/32	40	16DHDG	16D5HDG

- These coated fasteners possess a level of corrosion resistance that makes them suitable for use in some exterior and corrosive environments and with some preservative-treated woods. For applications in higher-exposure applications, consider Type-300 series stainless-steel fasteners for superior corrosion resistance. See page 15 for additional important information before selecting a fastener for a specific application.

PVC Trim-Board Nail

Specifically designed for use with PVC trim board. The spiral shank beginning of the nail allows the nail to smoothly work itself into the board. The ring-shank gives the nail great holding power. Nails that are fully ring shank can blast open the back of a trim board leading to looser fit. Smooth nails or trim nails do not have the same holding power or strength. The PVC trim-board nail is the best of both worlds.

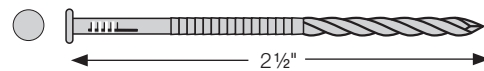

Type 316 Stainless Steel

Penny Size	Length (in.)	Screw Size/ Nail Gauge	Shank Dia. (in.)	Head Dia. (in.)	Shank	Head Type	Point	Count per lb. (approx)	Package Size	Model No.
8d	2½	13	0.95	0.205	Spiral/Ring Shank	Checkered Head	Diamond Point	196	1000	T8VTN1000



Crate Screw

Common Applications:

Crating and General Interior Applications

Features:

- Large hex-washer head provides excellent bearing area for a secure connection (0.64" head dia.)
- Hex drive reduces cam-outs for easier driving
- Black e-coat

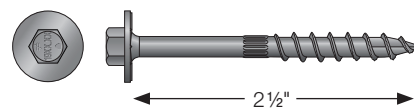

E-Coat

Size (Dia. x Length) (in.)	Thread Length (in.)	Fasteners Per Pack	Model No
0.195 x 2½	1½	1000	SDWH19212

Specialty

Escutcheon Pins

Features:

- Oval head with diamond point
- Other materials are available for special-order; please call Simpson Strong-Tie for details (800) 999-5099.

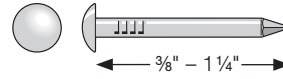

Type 304 Stainless Steel

Length (in.)	Wire Gauge	Shank Diameter (in.)	Head Diameter (in.)	Approx Count per lb.	1/8 lb. Model No.	1 lb. Model No.	5 lb. Model No.
3/8	18	0.049	0.100	3900	518037EP18	S18037EP1	—
1/2	18	0.049	0.100	3000	518050EP18	S18050EP1	—
3/4	18	0.049	0.100	2500	518075EP18	—	S18075EP5
1	18	0.049	0.100	1700	518100EP18	—	—
3/8	16	0.065	0.125	2400	516037EP18	—	—
1/2	16	0.065	0.125	1670	516050EP18	S16050EP1	S16050EP5
5/8	16	0.065	0.125	1395	516062EP18	S16062EP1	S16062EP5
3/4	16	0.065	0.125	1200	516075EP18	S16075EP1	S16075EP5
1	16	0.065	0.125	1000	516100EP18	S16100EP5	—
1 1/4	16	0.065	0.125	750	—	—	—
1/2	14	0.083	0.160	980	—	S14050EP1	S14050EP5
3/4	14	0.083	0.160	700	514075EP18	S14075EP1	S14075EP5
1	14	0.083	0.160	550	514100EP18	S14100EP1	S14100EP5
1 1/4	14	0.083	0.160	450	514125EP18	—	—
1/2	14	0.083	0.160	380	514150EP18	S14150EP5	—
1/2	12	0.113	0.223	625	512050EP18	—	—
3/4	12	0.113	0.223	454	512075EP18	—	—

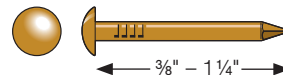

Brass

Length (in.)	Wire Gauge	Shank Diameter (in.)	Head Diameter (in.)	Approx Count per lb.	1/8 lb. Model No.	1 lb. Model No.	5 lb. Model No.
3/8	18	0.049	0.100	3900	—	—	—
1/2	18	0.049	0.100	3000	B18050EP18	B18050EP1	—
3/4	18	0.049	0.100	2500	B18075EP18	B18075EP1	—
1	18	0.049	0.100	1700	B18100EP18	B18100EP1	—
3/8	16	0.065	0.125	2400	—	—	—
1/2	16	0.065	0.125	1670	—	B16050EP1	—
5/8	16	0.065	0.125	1395	—	B16062EP1	—
3/4	16	0.065	0.125	1200	—	B16075EP1	B16075EP5
1	16	0.065	0.125	1000	—	B16100EP1	B16100EP5
1 1/4	16	0.065	0.125	750	—	B16125EP1	B16125EP5
1/2	14	0.083	0.160	980	—	B14050EP1	B14050EP5
3/4	14	0.083	0.160	700	—	B14075EP1	B14100EP5
1	14	0.083	0.160	550	—	B14100EP1	—
1 1/4	14	0.083	0.160	450	—	B14125EP1	—
1/2	14	0.083	0.160	380	—	B14150EP1	—
1/2	12	0.113	0.223	625	B12050EP18	—	—
3/4	12	0.113	0.223	454	B12075EP18	—	—

Specialty

Fencing Staples

Type 304 Stainless Steel

Length (in.)	Screw Size/Nail Gauge	Count per lb. (approx)	Package Size	Model No.
1	13	291	1 lb.	S13100FS1
1	13	291	5 lb.	S13100FS5
1	13	291	25 lb.	S13100FSB
1¼	13	202	1 lb.	S13125FS1
1¼	13	202	5 lb.	S13125FS5
1¼	13	202	25 lb.	S13125FSB
2	10	66	1 lb.	S10200FS1
2	10	66	5 lb.	S10200FS5
2	10	66	25 lb.	S10200FSB

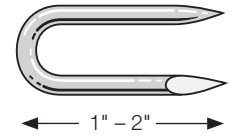

Hog Rings – Blair Shaped

Type 304 Stainless Steel

Gauge	Width Open (in.)	Width Across (in.)	Approx. Count per lb.	1 lb. Model No.	5 lb. Model No.	25 lb. Bucket Model No.
12	0.95	1.82	111	S12131HR1	S12131HR5	S12131HRB

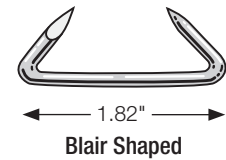

Hog Rings – Hill Pattern

Features:

- #3 Pre-Bent

Type 304 Stainless Steel

Gauge	Width Open (in.)	Width Across (in.)	Approx. Count per lb.	1 lb. Model No.	5 lb. Model No.	25 lb. Bucket Model No.
13	0.812	1.57	204	S13075HR1	S13075HR5	S13075HRB
14	0.280	0.75	540	S14075HR1	S14075HR5	S14075HRB

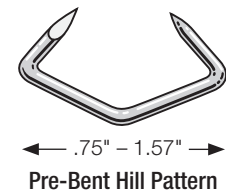

Specialty

Marine Screw – Pan Head

Common Applications:

Designed to fasten securely in fiberglass, plywood and wood-substitute materials in applications exposed to harsh marine or many chemically caustic conditions. Ideal for applying trim, rub rail and molding to fiberglass boat hulls.

Features:

- Specially engineered, high/low thread form incorporates indentations (“teeth”) that cut easily and quickly through high-density materials
- Extra-sharp points speed screw starts during assembly
- Back-out resistance: once driven home, “teeth” lock the fastener into place (*the thread indentations will resist back-out even after prolonged vibration*)
- Screws up to 1" in length are fully threaded. Screws more than 1" long are threaded $\frac{2}{3}$ of the shank length
- #2 Phillips drive (sizes #6, #8, #10)
- #3 Phillips drive (sizes #12, #14)

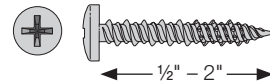

Type 316 Stainless Steel

Size	Length (in.)	Head Diameter (in.)	Nominal Screw Diameter (in.)	100-Count Model No.	1000-Count Model No.
#6	1/2	0.263	0.138	T06J050PXC	T06J050PXM
#8	1/2	0.314	0.164	T08J050PXC	T08J050PXM
#10	1/2	0.365	0.190	T10J050PXC	T10J050PXM
#6	3/4	0.263	0.138	T06J075PXC	T06J075PXM
#8	3/4	0.314	0.164	T08J075PXC	T08J075PXM
#10	3/4	0.365	0.190	T10J075PXC	T10J075PXM
#6	1	0.263	0.138	T06J100PXC	T06J100PXM
#8	1	0.314	0.164	T08J100PXC	T08J100PXM
#10	1	0.365	0.190	T10J100PXC	T10J100PXM
#12	1	0.416	0.216	T12J100PXC	T12J100PXM
#14	1	0.483	0.242	T14J100PXC	T14J100PXM
#8	1 1/4	0.314	0.164	T08J125PXC	T08J125PXM
#10	1 1/4	0.365	0.190	T10J125PXC	T10J125PXM
#12	1 1/2	0.416	0.216	T12J150PXC	T12J150PXM
#14	1 1/2	0.483	0.242	T14J150PXC	T14J150PXM
#12	2	0.416	0.216	T12J200PXC	T12J200PXM
#14	2	0.483	0.242	T14J200PXC	T14J200PXM

Specialty

Marine Screw – Flat Head

Common Applications:

Designed to fasten securely in fiberglass, plywood and wood-substitute materials in applications exposed to harsh marine or many chemically caustic conditions. Ideal for applying trim, rub rail and molding to fiberglass boat hulls.

Features:

- Specially engineered, high/low thread form incorporates indentations (“teeth”) that cut easily and quickly through high-density materials
- Extra-sharp points speed screw starts during assembly
- Back-out resistance: once driven home, “teeth” lock the fastener into place (*the thread indentations will resist back-out even after prolonged vibration*)
- Screws up to 1" in length are fully threaded. Screws more than 1" long are threaded $\frac{2}{3}$ of the shank length
- #2 Phillips drive

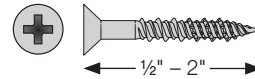

Type 316 Stainless Steel

Size	Length (in.)	Head Diameter* (in.)	Nominal Screw Diameter (in.)	100-Count Model No.	1000-Count Model No.
#6	1/2	0.262	0.138	T06J050FXC	T06J050FXM
#6	3/4	0.262	0.138	T06J075FXC	T06J075FXM
#8	3/4	0.312	0.164	T08J075FXC	T08J075FXM
#6	1	0.262	0.138	T06J100FXC	T06J100FXM
#8	1	0.310	0.164	T08J100FXC	T08J100FXM
#10	1	0.363	0.190	T10J100FXC	T10J100FXM
#8	1 1/4	0.312	0.164	T08J125FXC	T08J125FXM
#10	1 1/4	0.363	0.190	T10J125FXC	T10J125FXM
#8	1 1/2	0.312	0.164	T08J150FXC	T08J150FXM
#10	1 1/2	0.363	0.190	T10J150FXC	T10J150FXM
#10	2	0.363	0.190	T10J200FXC	T10J200FXM

Specialty

Marine Screw – Oval Head

Common Applications:

Designed to fasten securely in fiberglass, plywood and wood-substitute materials in applications exposed to harsh marine or many chemically caustic conditions. Ideal for applying trim, rub rail and molding to fiberglass boat hulls.

Features:

- Specially engineered, high/low thread form incorporates indentations (“teeth”) that cut easily and quickly through high-density materials
- Extra-sharp points speed screw starts during assembly
- Back-out resistance: once driven home, “teeth” lock the fastener into place (*the thread indentations will resist back-out even after prolonged vibration*)
- Screws up to 1" in length are fully threaded. Screws more than 1" long are threaded $\frac{2}{3}$ of the shank length
- #2 Phillips drive (sizes #6, #8, #10)
- #3 Phillips drive (sizes #12, #14)

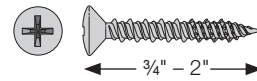

Type 316 Stainless Steel

Size	Length (in.)	Head Diameter* (in.)	Nominal Screw Diameter (in.)	100-Count Model No.	1000-Count Model No.
#6	¾	0.262	0.138	T06J0750XC	T06J0750XM
#8	¾	0.312	0.164	T08J0750XC	T08J0750XM
#10	¾	0.363	0.190	T10J0750XC	T10J0750XM
#6	1	0.262	0.138	T06J1000XC	T06J1000XM
#8	1	0.312	0.164	T08J1000XC	T08J1000XM
#10	1	0.363	0.190	T10J1000XC	T10J1000XM
#12	1	0.396	0.216	T12J1000XC	T12J1000XM
#14	1	0.445	0.242	T14J1000XC	T14J1000XM
#8	1¼	0.312	0.164	T08J1250XC	T08J1250XM
#10	1¼	0.363	0.190	T10J1250XC	T10J1250XM
#8	1½	0.312	0.164	T08J1500XC	T08J1500XM
#10	1½	0.363	0.190	T10J1500XC	T10J1500XM
#12	1½	0.396	0.216	T12J1500XC	T12J1500XM
#14	1½	0.445	0.242	T14J1500XC	T14J1500XM
#12	2	0.396	0.216	T12J2000XC	T12J2000XM
#14	2	0.445	0.242	T14J2000XC	T14J2000XM

Specialty

Fiber-Cement Screw

Features:

- Wafer head with self-countersinking nibs
- Type-17 point for fast starts
- Coarse thread full length (to within $\frac{5}{16}$ " of head)
- Driver bit included in each package
- Use $1\frac{1}{4}$ " screws to attach fiber cement siding to stress skin panels
- Use $1\frac{5}{8}$ " screws to blind-fasten fiber cement lap siding to wood
- #2 square drive (replacement bit model BIT2S-2, see page 133 for more information)

Type 316 Stainless Steel

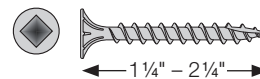

Size	Length (in.)	Head Diameter (in.)	Carton Quantity	Model No.
#8	1 $\frac{1}{4}$	0.390	100	T08C125WQC
#8	1 $\frac{1}{4}$	0.390	1000	T08C125WQM
#8	1 $\frac{5}{8}$	0.390	100	T08C162WQC
#8	1 $\frac{5}{8}$	0.390	1000	T08C162WQM
#8	2 $\frac{1}{4}$	0.390	100	T08225WQ1
#8	2 $\frac{1}{4}$	0.390	1000	T08C225WQM
#8	2 $\frac{1}{4}$	0.390	2000	T08C225WQC

Specialty

Metal-Panel Screw

Common Applications:

Aluminum agricultural siding panels to wood joists without pre-drilling

Features:

- Extra-sharp point for quick penetration of aluminum panels without “point walking”
- Twin-lead thread fastens one to three panel thicknesses securely to wood substrate
- ¼" hex drive
- Limited models available in Type 305 stainless steel; please call Simpson Strong-Tie for availability (800) 999-5099.

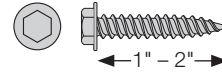

Type 316 Stainless Steel

Size	Length (in.)	Head Diameter (in.)	Carton Quantity	Model No.
#9	1	0.399	100	T09100HWHC
#9	1	0.399	1000	T09100HWHM
#9	1½	0.399	100	T09150HWHC
#9	1½	0.399	1000	T09150HWHM
#9	2	0.399	100	T09200HWHC
#9	2	0.399	1000	T09200HWHM

Metal-Panel Screw with EPDM Washer

Common Applications:

Aluminum agricultural siding panels to wood joists without pre-drilling

Features:

- Extra-sharp point for quick penetration of aluminum panels without “point walking”
- Twin-lead thread fastens one to three panel thicknesses securely to wood substrate
- Washers are made of Type 316 stainless steel
- ¼" hex drive
- Limited models available in Type 305 stainless steel; please call Simpson Strong-Tie for availability (800) 999-5099.

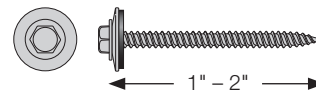

Type 316 Stainless Steel

Size	Length (in.)	Washer Diameter (in.)	Carton Quantity	Model No.
#9	1	0.630	100	T09100HWAC
#9	1	0.630	1000	T09100HWAM
#9	1½	0.630	100	T09150HWAC
#9	1½	0.630	1000	T09150HWAM
#9	2	0.630	100	T09200HWAC
#9	2	0.630	1000	T09200HWAM

Specialty

Self-Drilling Hex-Washer Head Screw

Common Applications:

Aluminum and fiberglass fastening (*not steel*)

Features:

- Indented hex-washer head
- Tapping screw thread
- #3 drill point

For more information on drilling thickness capacities and drill speed recommendations see pages 23-24.

Types 316 and 305 stainless steel provide superior corrosion resistance and are suitable for softer materials such as aluminum and fiberglass (*not steel*).

Type 316 Stainless Steel

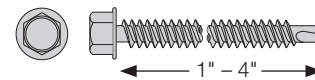

Size	Length (in.)	Hex Head Size (in.)	Threads Per Inch	Carton Quantity	Model No.
#8	1	1/4	18	100	T08100HDUC
#8	1	1/4	18	1000	T08100HDUM
#12	1	5/16	14	100	T12100HDUC
#12	1	5/16	14	1000	T12100HDUM
#12	1½	5/16	14	100	T12150HDUC
#12	1½	5/16	14	1000	T12150HDUM
#12	2	5/16	14	100	T12200HDUC
#12	2	5/16	14	1000	T12200HDUM
#12	2½	5/16	14	100	T12250HDUC
#12	2½	5/16	14	1000	T12250HDUM
#12	3	5/16	14	100	T12300HDUC
#12	3	5/16	14	1000	T12300HDUM
#12	4	5/16	14	100	T12400HDUC
#12	4	5/16	14	1000	T12400HDUM

Type 305 Stainless Steel

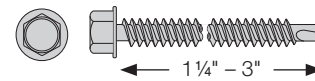

Size	Length (in.)	Hex Head Size (in.)	Threads Per Inch	Carton Quantity	Model No.
#12	1¼	5/16	14	100	S12125HDUC
#12	1¼	5/16	14	1000	S12125HDUM
#12	1½	5/16	14	100	S12150HDUC
#12	1½	5/16	14	1000	S12150HDUM
#12	2	5/16	14	100	S12200HDUC
#12	2	5/16	14	1000	S12200HDUM
#12	2½	5/16	14	100	S12250HDUC
#12	2½	5/16	14	1000	S12250HDUM
#12	3	5/16	14	100	S12300HDUC
#12	3	5/16	14	1000	S12300HDUM

Specialty

Self-Drilling Hex-Washer Head Screw with EPDM Sealing Washer

Common Applications:

Aluminum and fiberglass fastening (*not steel*)

Features:

- Indented hex-washer head
- Washers are Type 316 stainless steel for 316 stainless-steel screws and Type 305 stainless steel for 305 stainless-steel screws
- Tapping screw thread
- #3 drill point

For more information on drilling thickness capacities and drill speed recommendations see pages 23-24.

Types 316 and 305 stainless steel provide superior corrosion resistance and are suitable for softer materials such as aluminum and fiberglass (*not steel*).

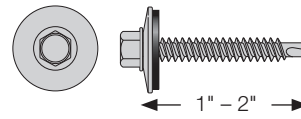

Type 316 Stainless Steel

Size	Length (in.)	Threads Per Inch	Head Size (in.)	Washer Diameter (in.)	Carton Count	Model No.
#12	1	14	5/16	0.625	100	T12100XOC
#12	1	14	5/16	0.625	1000	T12100XOM
#12	1½	14	5/16	0.625	100	T12150XOC
#12	1½	14	5/16	0.625	1000	T12150XOM
#12	2	14	5/16	0.625	100	T12200XOC
#12	2	14	5/16	0.625	1000	T12200XOM

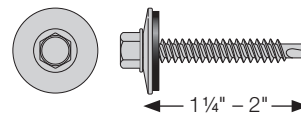

Type 305 Stainless Steel

Size	Length (in.)	Threads Per Inch	Head Size (in.)	Washer Diameter (in.)	Carton Count	Model No.
#12	1¼	14	5/16	0.625	100	S12125HOC
#12	1¼	14	5/16	0.625	1000	S12125HOM
#12	1½	14	5/16	0.625	100	S12150HOC
#12	1½	14	5/16	0.625	1000	S12150HOM
#12	2	14	5/16	0.625	100	S12200HOC
#12	2	14	5/16	0.625	1000	S12200HOM

Specialty

Self-Drilling Flat-Pan-Head Screw

Common Applications:

Aluminum and fiberglass fastening (*not steel*)

Features:

- Fully threaded
- #3 drill point
- #2 square drive (replacement bit BIT2S-2, see page 133 for more information)

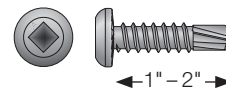

Type 305 Stainless Steel

Size	Length (in.)	Threads Per Inch	Head Diameter* (in.)	Drill Point Size	Carton Quantity	Model No.
#10	1	16	0.365	#3	25	S10T100PDQ25
#10	1	16	0.365	#3	100	S10T100PDC
#10	1	16	0.365	#3	1000	S10T100PDM
#10	1¼	16	0.365	#3	25	S10T125P25
#10	1¼	16	0.365	#3	100	S10T125PDC
#10	1¼	16	0.365	#3	1000	S10T125PDM
#10	1½	16	0.365	#3	25	S10T150P25
#10	1½	16	0.365	#3	100	S10T150PDC
#10	1½	16	0.365	#3	1000	S10T150PDM
#10	2	16	0.365	#3	25	S10T200P25
#10	2	16	0.365	#3	100	S10T200PDC
#10	2	16	0.365	#3	1000	S10T200PDM

Pancake-Head Screw

Common Applications:

Securing clips to wood used in standing-seam roofing

Features:

- Low-profile head
- #2 square drive (replacement bit BIT2S-2, see page 133 for more information)
- Fully threaded shank
- Type 410 stainless steel is coated for additional corrosion protection

Type 410 stainless steel can be hardened through heat treatment, giving it the ability to drill through metal. It does not offer the same level of corrosion resistance of either Type 316 or 305 stainless steel.

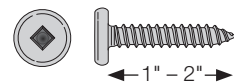

Type 410 Stainless Steel

Size	Length (in.)	Head Diameter* (in.)	Carton Quantity	Model No.
#10	1	0.438	100	F10T100PTC
#10	1	0.438	1000	F10T100PTM
#10	1	0.438	4500	F10T100PTB
#10	2	0.438	100	F10T200PTC
#10	2	0.438	1000	F10T200PTM

Specialty

PCULP Standing-Seam-Roofing Panel Clip Screw

Common Application:

Standing-seam-roofing panel clips to wood

Features:

- Ultra low profile pancake head
- #2 square drive
- Type 410 stainless steel is coated for additional corrosion protection
- Type-17 point
- Also ideal for fastening panel flanges for snap-and-seam metal roofing

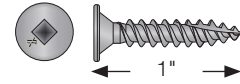

Type 410 Stainless Steel

Size	Length (in.)	Thread Per Inch	Head Diameter (in.)	Carton Quantity	Model No.
#10	1	12	0.405	5000	SSPCULP1B1012-5K

See load tables on page 329.

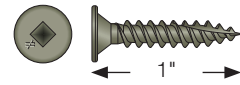

Quik Guard® Coating

Size	Length (in.)	Thread Per Inch	Head Diameter (in.)	Carton Quantity	Model No.
#10	1	12	0.405	5000	PCULPQ1B1012-5K

See load tables on page 329.

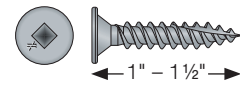

Clear Zinc Coating

Size	Length (in.)	Thread Per Inch	Head Diameter (in.)	Carton Quantity	Model No.
#10	1	12	0.405	5000	PCULP1B1012-5K
#10	1½	12	0.405	4000	PCULP112B1012-4K

See load tables on page 329.

PC Standing-Seam-Roofing Panel Clip Screw

Common Application:

Standing-seam-roofing panel clips to wood

Features:

- Pancake head
- #2 square drive
- Type-17 point

Quik Guard® Coating

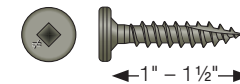

Size	Length (in.)	Thread Per Inch	Head Diameter (in.)	Carton Quantity	Model No.
#10	1	12	0.405	5000	PCQ1B1012-5K
#10	1½	12	0.405	4000	PCQ112B1012-4K
#12	1	11	0.405	4000	PCQ1B1211-4K

Clear Zinc Coating

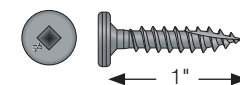

Size	Length (in.)	Thread Per Inch	Head Diameter (in.)	Carton Quantity	Model No.
#10	1	12	0.405	5000	PC1B1012-5K
#12	1	11	0.405	4000	PC1B1211-4K

Specialty

Trim-Head Screw with EPDM Sealing Washer

Common Application:

Assemblies provide weathertight seal for use in exterior sheathing and roofing applications.

Features:

- #1 square drive (replacement bit model BIT1S-2, see page 133 for more information)
- Washers are $\frac{5}{8}$ " in diameter and are made from Type 305 stainless steel with a EPDM gasket
- Type-17 point
- Other sizes are available for special-order, please call Simpson Strong-Tie for details (800) 999-5099

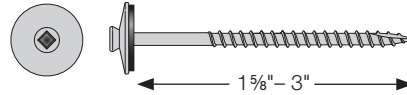

Type 305 Stainless Steel

Size	Length (in.)	Washer Diameter (in.)	Carton Quantity	Model No.
#7	1 $\frac{5}{8}$	0.625	100	S07C162X0C
#7	1 $\frac{5}{8}$	0.625	1000	S07C162X0M
#7	2 $\frac{1}{4}$	0.625	100	S07C225X0C
#7	2 $\frac{1}{4}$	0.625	1000	S07C225X0M
#7	3	0.625	100	S07C300X0C

Wire-Lath Modified Truss-Head Screw

Common Application:

Fastening lath to wood

Features:

- For use in applications where a larger bearing surface is needed underneath the head
- #2 Phillips drive
- Type-17 point

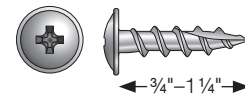

Type 305 Stainless Steel

Size	Length (in.)	Head Diameter (in.)	Carton Quantity	Model No.
#8	$\frac{3}{4}$	0.423	100	S08C075KQC
#8	$\frac{3}{4}$	0.423	1000	S08C075KQM
#8	1 $\frac{1}{4}$	0.423	100	S08C125KQC
#8	1 $\frac{1}{4}$	0.423	1000	S08C125KQM

Specialty

Truss-Head Screw

Common Application:

Fasten all materials to wood or wood-substitute materials

Features:

- Square drive
- Type-17 point
- Coarse thread
- Pre-drilling recommended dependent on substrate
- Oversized head
- #2 square drive (replacement bit model BIT2S-2, see page 133 for more information)

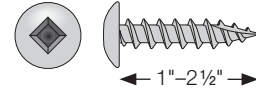

Type 305 Stainless Steel

Size	Length (in.)	Head Diameter (in.)	Carton Quantity	Model No.
#8	1	0.374	100	S08C100TSC
#8	1	0.374	1000	S08C100TSM
#8	1	0.374	2000	S08100TSBC
#8	1¼	0.374	100	S08C125TSC
#8	1¼	0.374	1000	S08C125TSM
#8	1¼	0.374	2000	S08125TSBC
#8	1½	0.374	100	S08C150TSC
#8	1½	0.374	1000	S08C150TSM
#8	1½	0.374	2000	S08150TSBC
#8	2½	0.374	100	S08C250TSC
#8	2½	0.374	1000	S08C250TSM
#8	2½	0.374	2000	S08250TSBC

Specialty

Pocket-Hole Screw

Common Application:

Pocket-holes for finish work and cabinetry

Features:

- Type-17 point
- #2 square drive
(replacement bit model BIT2S-2,
see page 133 for more information)

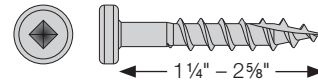

Type 305 Stainless Steel

Size	Length (in.)	Head Diameter (in.)	Carton Quantity	Model No.
#10	1 1/4	0.356	1500	S10125PHB
#10	2 5/8	0.356	1500	S10262PHB

Specialty

Storm-Panel Screw

Common Application:

Ideal for attaching storm panels to wood, concrete and masonry

Features:

- Save time and money with a single installation
- The screw is made of Type 302 stainless steel for corrosion resistance

Each pack contains:

- (25) Stainless-steel storm-panel screws 1/4" x 3 7/16"
- (25) 1/4" zinc die-cast washered wing nuts
- (25) White plastic caps to protect threads after panels are removed
- (1) Hex driver bit for panel screw
- (1) 0.234" x 4 1/2" carbide-tipped drill bit

Installation:

1. Drill a hole in the concrete or masonry base material using the drill bit provided. To pre-drill into wood, use a 3/16" bit.
2. Position the panel and drive the screw using the hex driver bit (included). Drive the screw deep enough so that the bottom of the threads for the wing nut are slightly below the surface of the panel.
3. Secure the panel with the wing nut.
4. To remove panels – remove the wing nut, remove the panel and cover the threads on the screw with the plastic cap.

Storm-Panel Screw Pack

Size (in.)	Length (in.)	Model No.
1/4	3 7/16	SPS25344-KT

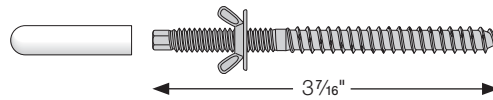

Storm-Panel Screw Replacement Parts

Description	Carton Qty.	Model No.
1/4" white plastic caps	100	PCAPS100
1/4" zinc die-cast washered wing nuts	100	Z25CWWNC

Specialty

Specialty Washer for Nail and Screw Assemblies

Bonded-EPDM washers provide a weather-resistant seal for exterior sheathing and roofing applications.

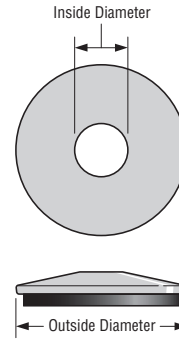

Type 316 Stainless Steel

Inside Diameter	Outside Diameter (in.)	Carton Count	Model No.
#10	5/8	100	T10N062SWC
#10	5/8	1000	T10N062SWM
#12	5/8	100	T12N062SWC
#12	5/8	1000	T12N062SWM
#14	1 1/8	100	T25N112SWC
#14	1 1/8	1000	T25N112SWM

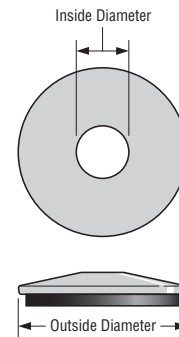

Type 304 Stainless Steel

Inside Diameter	Outside Diameter (in.)	Carton Count	Model No.
#10	5/8	100	S10N062SWC
#10	5/8	1000	S10N062SWM
#12	5/8	100	S12N062SWC
#12	5/8	1000	S12N062SWM
#10	1 1/8	100	S10N112SWC
#10	1 1/8	1000	S10N112SWM

Specialty

EB-TY® Hidden Deck Fasteners

The EB-TY provides a unique method of fastening deck boards that makes the fasteners virtually invisible. Fastening is done into the side of the board, leaving a fastener-free deck surface.

The EB-TY is a polypropylene biscuit fastener that fits into a slot the builder cuts into the edge of the deck boards with a standard biscuit joiner. The EB-TY fasteners are inserted and fastened with a screw driven into the joist. Nesting each successive board against the EB-TY automatically ensures consistent spacing and uniform height.

Features:

- Easy to install since all fastening is done from the top side
- Affords easier deck resurfacing since fastener heads are below from the deck surface
- Formed from long lasting polypropylene to last the life of the deck
- Stainless-steel #7 trim-head screws included (*black head, 6-lobe drive*)
- Each EB-TY package includes installation instructions and enough EB-TY fasteners, screws and tapered Ipê wood plugs to install 100 square feet of decking (*175-Pack quantity assumes 6" wide boards, installed perpendicular to joists spaced 16" on center*)

U. S. Patents: 6,402,415 and 7,578,105

For installation information, see page 327



Working from left to right, compare the information in the columns to your application to select the correct EB-TY for the job.

Decking Material	Decking Thickness (in.)	Spacing Requirement (in.)	Special Application Information	Biscuit Model No.	Ordering Information	
					Pack Quantity	Pack Model No.
Ipê	1+	3/32	N/A	EBE004	100	100-EB TYS
Redwood					175	175-EB TYS
Cedar					275	275-EB TYS
PVC					175	175-EB TYW*
Ipê	1+	3/32	1 5/8" screw included for installation on roof-deck sleepers	EBE004	175	175-EB162
Redwood						
Cedar						
PVC						
Ipê	1 1/16 +	3/32	N/A	EBE007MINI	100	100-EBTYMI
Redwood					175	175-EBTYMI
Cedar						
PVC						
Docks	2x4 and 2x6	1/4	N/A	EBE002	175	175-EBTYBG
Boardwalks						
Kiln-dried	1+	1/4	"Live Cylinder" design for expansive material	EBE005LC	100	100-EBTYLC
Composites					175	175-EBTYLC
Natural Woods					275	275-EBTYLC
Kiln-dried	1 1/16 +	1/4	"Live Cylinder" design for expansive material	EBE006JR	175	175-EBTYJR
Composites					100	100-EBTYJR
Natural Woods						
Timber Tech®	7/8 +	3/16	N/A	316-TT	175	175-EB TT
PVC/Composite	7/8 +	1/8	N/A	EBEOA	175	175-EBAOSQ
Composites	7/8 +	3/16	N/A	TP015	175	175-EBTYP



Specialty

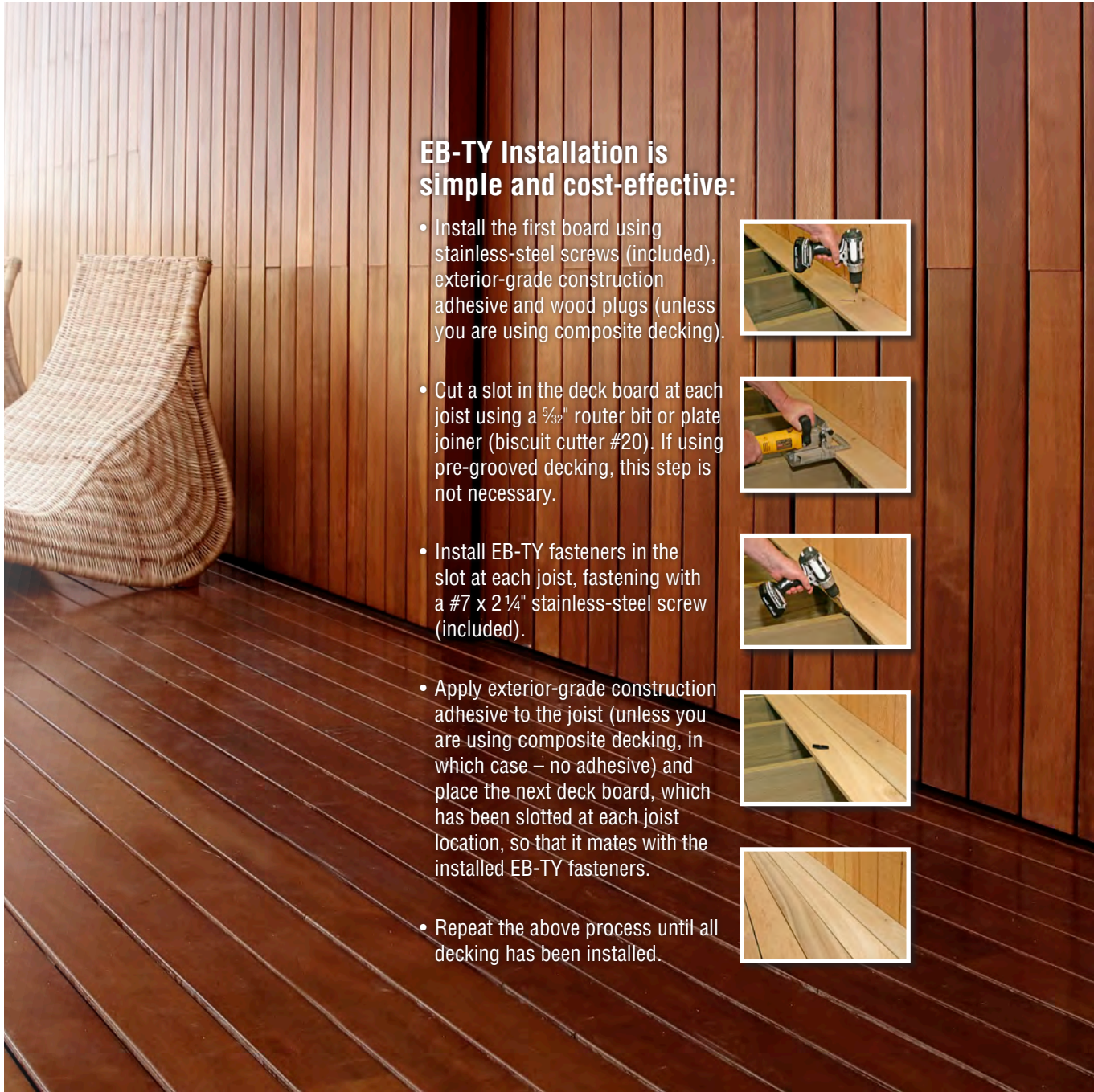

EB-TY Installation is simple and cost-effective:

- Install the first board using stainless-steel screws (included), exterior-grade construction adhesive and wood plugs (unless you are using composite decking).
- Cut a slot in the deck board at each joist using a $\frac{3}{32}$ " router bit or plate joiner (biscuit cutter #20). If using pre-grooved decking, this step is not necessary.
- Install EB-TY fasteners in the slot at each joist, fastening with a #7 x 2 1/4" stainless-steel screw (included).
- Apply exterior-grade construction adhesive to the joist (unless you are using composite decking, in which case – no adhesive) and place the next deck board, which has been slotted at each joist location, so that it mates with the installed EB-TY fasteners.
- Repeat the above process until all decking has been installed.

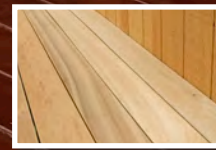
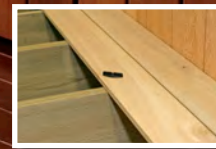

C-F-14 ©2014 SIMPSON STRONG-TIE COMPANY INC.

Ipê Wood Plugs

Features:

- Made of high quality Ipê and tapered for ease of use
- For use on decks using the EB-TY® system (first boards, aprons, etc.); also stairs, railings



Plug Diameter (in.)	Plug Length (in.)	Count Quantity	Model No.
$\frac{3}{8}$	$\frac{7}{16}$	100	WDPLUG-100
$\frac{3}{8}$	$\frac{7}{16}$	2000	WDPLUG2M

Metal Screws

Strong-Drive® XE EXTERIOR STRUCTURAL METAL Screw

For Simpson Strong-Tie® Connectors

Features:

- 5/16" hex head
- 16 threads per inch
- Dual hardened heat treatment improves drilling efficiency, maximizes ductility and reduces the potential for hydrogen embrittlement
- Quik Guard® coated for corrosion protection
- Meets ASTM C1513 drill-time performance
- Only fastener load rated for Simpson Strong-Tie® L70Z and LS70Z connectors for use with Trex® Elevations™ steel deck framing

For Technical Data and Loads, see page 312

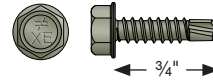

Quik Guard® Coating

Length (in.)	Screw Size/ Nail Gauge	Shank Dia. (in.)	Head Dia. (in.)	Drive	Head Type	Threads	Point	Point Size	Material/ Coating	Package Size	Model No.
3/4	10	0.19	0.4	5/16" Hex	Hex Washer Head	Machine Threads	#2 Drill Point	2	Quik Guard® Coating	100	XEQ34B1016C
3/4	10	0.19	0.4	5/16" Hex	Hex Washer Head	Machine Threads	#2 Drill Point	2	Quik Guard® Coating	1000	XEQ34B1016M

Metal Screws

Strong-Drive® PPSD SHEATHING-TO-CFS Screw

Wood Sheathing to Cold-Formed Steel

Common Application:

Subfloor/sheathing to cold-formed steel (#8 – maximum thickness: 54 mils/16 ga.; #10 and #12 – maximum thickness: 97 mils/12 ga.)

Features:

- Flat head with nibs for easier countersinking
- #3 square drive (replacement bit BIT3SU-2 for Quik Guard® and BIT3S-2 for yellow-zinc coating, see page 133 for more information)
- Fine threads
- Pilot point
- Head diameter meets AISI lateral design standard
- This screw is also available collated for the Quik Drive® system. See page 196 for details.

Codes/Standards: ASTM C1513 compliant

For Technical Data and Loads, see page 313

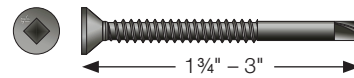

Quik Guard® Coating

Shank Size	Length (in.)	Head Diameter (in.)	Point Size	Threads Per Inch	Carton Quantity	Model No.
#8	1 5/16	0.323	2	18	4000	PPSDQ11516B-4K
#10	1 3/4	0.333	3	16	4000	PPSDQ134B1016-4K
#12	1 3/4	0.333	3	16	4000	PPSDQ134B1214-4K*
#10	3	0.333	3	16	2000	PPSDQ3B1016-2K
#12	3	0.333	3	16	2000	PPSDQ3B1214-2K*

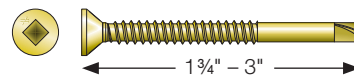

Yellow Zinc Coating

Shank Size	Length (in.)	Head Diameter (in.)	Point Size	Threads Per Inch	Carton Quantity	Model No.
#8	1 5/16	0.323	2	18	4000	PPSD11516B-4K
#10	1 3/4	0.333	3	16	4000	PPSD134B1016-4K
#12	1 3/4	0.333	3	16	4000	PPSD134B1214-4K*
#10	3	0.333	3	16	2000	PPSD3B1016-2K
#12	3	0.333	3	16	2000	PPSD3B1214-2K*

* Has underhead nibs

Metal Screws

Strong-Drive® FPHSD FRAMING-TO-CFS Screw

Cold-Formed Steel Framing

Common Application:

Cold-formed steel framing and sheet steel sheathing to cold-formed steel

Features:

- Flat pan head
- #3 square drive (Driver bit in each box; replacement bit model BIT3S-2)
- Self-drilling
- This screw is also available collated for the Quik Drive® system. See page 195 for details.

Codes/Standards: ASTM C1513 compliant

For Technical Data and Loads, see page 315

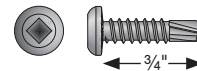

Clear Zinc Coating

Size	Length (in.)	Thread Per Inch	Head Diameter (in.)	Point Size	Approx. Count per lb.	1 lb. Model No.	Bulk	
							Carton Quantity	Model No.
#10	¾	16	0.365	#3	165	FPHSD34B1016	5000	FPHSD34B1016-5K
#12	¾	14	0.365	#3	147	FPHSD34B1214	5000	FPHSD34B1214-5K

Self-Drilling E Metal Screw

Common Application:

Cold-formed steel framing

Features:

- Hex-washer head
- Clear zinc finish
- Recommended for use with certain Simpson Strong-Tie® connectors
- #3 drill point (Max. total drilling thickness 0.35")
- Bit included in each box

Codes/Standards: ASTM C1513 compliant

For Technical Data and Loads, see page 328

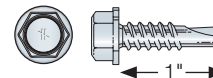

Clear Zinc Coating

Size	Length (in.)	Hex Head Size (in.)	Threads Per Inch	Head Diameter (in.)	Point Size	Carton Quantity	Model No.
#14	1	¾	14	0.5	#3	100	E1B1414R100
#14	1	¾	14	0.5	#3	2500	E1B1414B

Metal Screws

Self-Drilling X Metal Screw

Common Applications:

1. Steel decking to structural steel;
2. Steel stitching ("side-lap" stitching);
3. Cold-formed steel framing

Features:

- 5/16" hex head
- Drill point
- Hex washer head
- This screw is also available collated for the Quik Drive® system. See page 197 for details.

Codes/Standards: ICC-ES ESR-3006, City of LA RR25670 and RR25917, ASTM C1513 compliant, FM Approval #3045651, SDI DDM03, Appendix VII

WARNING: Industry studies show that hardened fasteners can experience performance problems in wet or corrosive environments. Accordingly, use this product in dry, interior, and noncorrosive environments only

For Technical Data and Loads, see page 332

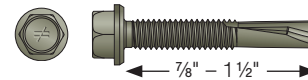

Quik Guard® Coating

Shank Size	Length (in.)	Threads per Inch	Point Size	Drill-Through Thickness (in.)	Finish	Carton Quantity	Model No.	Application(s)
10	1	16	3	.110 – .175	Quik Guard	4000	XQ1B1016-4K	2, 3
12	1	14	3	.110 – .210	Quik Guard	3500	XQ1B1214-3.5K	2, 3
12	7/8	24	4	.110 – .250	Quik Guard	3000	XQ78B1224-3K	1, 3
12	1 1/4	24	5	.125 – .500	Quik Guard	2500	XQ114B1224-2.5K	1, 3
12	1 1/2	24	5	.125 – .500	Quik Guard	2000	XQ112B1224-2K	1, 3

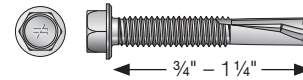

Clear-Zinc Coating

Shank Size	Length (in.)	Threads per Inch	Point Size	Drill-Through Thickness (in.)	Finish	Carton Quantity	Model No.	Application(s)
10	3/4	16	1	.030 – .110	Clear Zinc	5000	XU34B1016-5K	2, 3
10	3/4	16	3	.110 – .175	Clear Zinc	5000	X34B1016-5K	2, 3
10	1	16	3	.110 – .175	Clear Zinc	4000	X1B1016-4K	2, 3
12	1	14	3	.110 – .210	Clear Zinc	3500	X1B1214-3.5K	2, 3
12	1 1/4	24	5	.125 – .500	Clear Zinc	2500	X114B1224-2.5K	1, 3

Save Time with our Steel Deck Diaphragm Calculator

Generate diaphragm shear tables for various roof and floor decks attached using Simpson Strong-Tie® X-series screws. Create shear strength tables in Nominal, ASD or LRFD for various deck spans. The tables are calculated based on Steel Deck Institute (SDI) Diaphragm Design Manual, Third Edition (DDM03). The factors of safety are based on Table D5 of AISI S100, North American Specification for the Design of Cold-formed Steel Members.

- Requires minimal input to generate the tables
- Generate tables for any Simpson support or side lap fastener combination.
- Create custom table with any support fastener pattern chosen
- Accounts for wind uplift demand
- Choose the first deck span in the table; total of 10 deck spans are shown in increments of 6 in. from the minimum span chosen.
- Produce custom tables for floor decks with any typical fill type
- Generate tables in Nominal, ASD Wind, LRFD Wind, or LRFD EQ or ASD EQ.

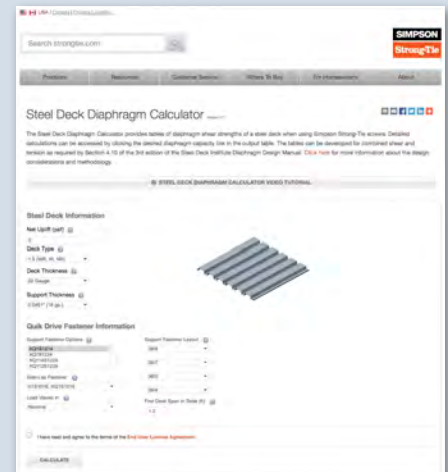

strongtie.com/diaphragmcalc



Metal Screws

PCSD Standing-Seam Roofing Panel Clip Screw

Common Application:

Standing-seam roofing panel clips to steel, sheet steel sheathing to cold-formed framing

Features:

- Pancake head
- #2 square drive (replacement bit BIT2SU-2 for Quik Guard®; BIT2S-2 for Type 410 stainless steel and clear-zinc coating, see page 133 for more information)
- Drill point
- Type 410 stainless steel is coated for additional corrosion protection
- This screw is also available collated for the Quik Drive® system. See page 198 for details.

Codes/Standards: ASTM C1513 compliant

For Technical Data and Loads, see pages 329-330

Type 410 Stainless Steel

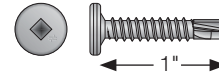

Size	Length (in.)	Thread Per Inch	Point Size	Head Diameter (in.)	Carton Quantity	Model No.
#10	1	16	#3	0.405	5000	SSPCSD1B1016-5K

Quik Guard® Coating

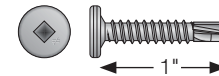

Size	Length (in.)	Thread Per Inch	Point Size	Head Diameter (in.)	Carton Quantity	Model No.
#10	1	16	#3	0.405	5000	PCSDQ1B1016-5K
#12	1	14	#3	0.405	4000	PCSDQ1B1214-4K

Clear Zinc Coating

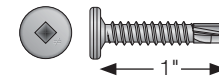

Size	Length (in.)	Thread Per Inch	Point Size	Head Diameter (in.)	Carton Quantity	Model No.
#10	1	16	#3	0.405	5000	PCSD1B1016-5K
#12	1	14	#3	0.405	4000	PCSD1B1214-4K

Self-Drilling Pancake-Head Screw

Common Application:

Ideal for securing clips used in standing-seam roofing

Features:

- Low-profile head
- #2 square drive (replacement bit model BIT2S-2, see page 133 for more information)
- Type 410 stainless steel is coated for additional corrosion protection
- #2 drill point Type 410 stainless steel can be hardened through heat treatment, giving it the ability to drill through metal. It does not offer the same level of corrosion resistance of either Type 316 or 305 stainless steel.
- **Warning:** Hardened stainless-steel fasteners should not be used with steel framing in environments with high humidity, condensation or other moisture that will be present at the dissimilar-metal interface.

For more information on drilling thickness capacities and drill speed recommendations see pages 23-24.

Type 410 Stainless Steel

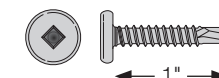

Size	Length (in.)	Threads Per Inch	Head Diameter (in.)	Carton Quantity	Model No.
#10	1	16	0.405	100	F10T100PSC
#10	1	16	0.405	1000	F10T100PSM
#10	1	16	0.405	4500	F10T100PSB

Metal Screws

Self-Drilling Bugle-Head Screw

Common Application:

Fasten wood, plywood and OSB panels to steel studs

Features:

- Bugle heads drive flush with work surface
- #2 square drive (replacement bit BIT2S-2)
- Tapping screw threads
- #3 drill point
- Type 410 stainless steel is coated for additional corrosion protection
- Type 410 stainless steel can be hardened through heat treatment, giving it the ability to drill through metal. It does not offer the same level of corrosion resistance of either Type 316 or 305 stainless steel.
- **Warning:** Hardened stainless-steel fasteners should not be used with steel framing in environments with high humidity, condensation or other moisture that will be present at the dissimilar-metal interface.

For more information on drilling thickness capacities and drill speed recommendations see pages 23-24.

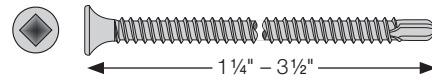

Type 410 Stainless Steel

Size	Length (in.)	Threads Per Inch	Head Diameter (in.)	Carton Quantity	Model No.
#6	1¼	20	0.344	100	F06T125BDC
#6	1¼	20	0.344	1000	F06T125BDM
#6	1¼	20	0.344	5000	F06T125BDB
#8	1⅝	18	0.344	100	F08T162BDC
#8	1⅝	18	0.344	1000	F08T162BDM
#8	1⅝	18	0.344	3000	F08T162BDB
#8	2	18	0.344	100	F08T200BDC
#8	2	18	0.344	1000	F08T200BDM
#8	2	18	0.344	2500	F08T200BDB
#10	2½	16	0.344	100	F10T250BDC
#10	2½	16	0.344	1000	F10T250BDM
#10	2½	16	0.344	2000	F10T250BDB
#10	3	16	0.344	100	F10T300BDC
#10	3	16	0.344	1500	F10T300BDB
#10	3½	16	0.344	100	F10T350BDC
#10	3½	16	0.344	1000	F10T350BDB

Metal Screws

Self-Drilling Fiber-Cement Screw

Common Application:

Fasten fiber cement through furring strips to steel studs

Features:

- Wafer head, square drive, self-countersinking nibs under the head
- Threaded to within $\frac{5}{16}$ " of top of head
- #3 drill point
- #2 square drive (replacement bit model BIT2S-2, see page 133 for more information)
- Type 410 stainless steel is coated for additional corrosion protection
- Type 410 stainless steel can be hardened through heat treatment, giving it the ability to drill through metal. It does not offer the same level of corrosion resistance of either Type 316 or 305 stainless steel.
- **Warning:** Hardened stainless-steel fasteners should not be used with steel framing in environments with high humidity, condensation or other moisture that will be present at the dissimilar-metal interface.

For more information on drilling thickness capacities and drill speed recommendations see pages 23-24.

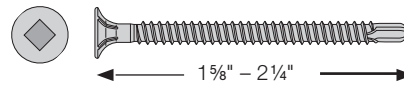

Type 410 Stainless Steel

Size	Length (in.)	Threads Per Inch	Head Diameter (in.)	Carton Quantity	Model No.
#8	1 $\frac{5}{8}$	18	0.390	100	F08T162WDC
#8	1 $\frac{5}{8}$	18	0.390	1000	F08T162WDM
#8	1 $\frac{5}{8}$	18	0.390	3000	F08T162WDB
#8	2 $\frac{1}{4}$	18	0.390	100	F08T225WDC
#8	2 $\frac{1}{4}$	18	0.390	1000	F08T225WDM
#8	2 $\frac{1}{4}$	18	0.390	2500	F08T225WDB

Metal Screws

Self-Drilling Flat-Head Screw with Wings

Common Application:

Fasten wood, plywood and fiber cement to steel – up to 0.209" thick

Features:

- Flat countersunk head with self-countersinking nibs
- #3 square drive (replacement bit model BIT3S-2, see page 133 for more information)
- Machine screw thread, threaded full length
- Shank slot enhances thread formation in steel and removes exhaust
- Wings above drill point provide clearance hole in work piece so it won't climb up the shank, then break off as point engages the steel substrate
- 2½" length for 2x wood; 2" length for 1" and ¾" boards
- Type 410 stainless steel is coated for additional corrosion protection
- Type 410 stainless steel can be hardened through heat treatment, giving it the ability to drill through metal. It does not offer the same level of corrosion resistance of either Type 316 or 305 stainless steel.
- **Warning:** Hardened stainless-steel fasteners should not be used with steel framing in environments with high humidity, condensation or other moisture that will be present at the dissimilar-metal interface.

For more information on drilling thickness capacities and drill speed recommendations see pages 23-24.

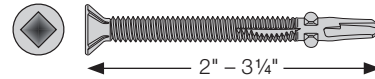

Type 410 Stainless Steel

Size	Length (in.)	Threads Per Inch	Head Diameter (in.)	Drill Point Size	Carton Quantity	Model No.
#12	2	24	0.375	#3	100	F12C200FDC
#12	2	24	0.375	#3	1000	F12C200FDM
#12	2	24	0.375	#3	2500	F12C200FDB
#12	2½	24	0.375	#3	100	F12C250FDC
#12	2½	24	0.375	#3	1000	F12C250FDM
#12	2½	24	0.375	#3	1800	F12C250FDB
#14	¾	20	0.468	#4	100	F14C325FDC
#14	¾	20	0.468	#4	1000	F14C325FDB

Metal Screws

Self-Drilling Siding Screw

Common Application:

Attach wood siding, wood panels and metal trim to steel studs

Features:

- Trim head
- Threaded $\frac{2}{3}$ of overall length
- #3 drill point
- #1 square drive (replacement bit model BIT1S-2, see page 133 for more information)
- Type 410 stainless steel can be hardened through heat treatment, giving it the ability to drill through metal. It does not offer the same level of corrosion resistance of either Type 316 or 305 stainless steel.
- **Warning:** Hardened stainless-steel fasteners should not be used with steel framing in environments with high humidity, condensation or other moisture that will be present at the dissimilar-metal interface.

For more information on drilling thickness capacities and drill speed recommendations see pages 23-24.

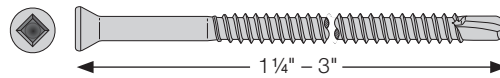

Type 410 Stainless-Steel

Size	Length (in.)	Threads Per Inch	Head Diameter (in.)	Approx. Count per lb.	Carton Quantity	Model No.
#6	1 1/4	20	0.230	—	—	F06T125TDB
#7	1 5/8	19	0.230	187	100	F07T162TDC
#7	1 5/8	19	0.230	187	1000	F07T162TDM
#7	1 5/8	19	0.230	187	5000	F07T162TDB
#7	2 1/4	19	0.230	132	100	F07T225TDC
#7	2 1/4	19	0.230	132	1000	F07T225TDM
#7	2 1/4	19	0.230	132	4000	F07T225TDB
#7	3	19	0.230	105	100	F07T300TDC
#7	3	19	0.230	105	1000	F07T300TDM
#7	3	19	0.230	105	2000	F07T300TDB

Metal Screws

Self-Drilling Truss-Head Screw

Common Application:

Secure single-ply membrane through insulation to steel purlins

Features:

- #3 Phillips drive
- Tapping screw thread (13 threads per inch)
- Drill point
- Factory Mutual approved for fastening to 16–22 gauge steel and wood decking
- Type 410 stainless steel can be hardened through heat treatment, giving it the ability to drill through metal. It does not offer the same level of corrosion resistance of either Type 316 or 305 stainless steel.
- These nails are special-order, non-stock items and are subject to minimum order quantities and longer lead times. Please call Simpson Strong-Tie for details (800) 999-5099.

For more information on drilling thickness capacities and drill speed recommendations see pages 23-24.

Warning: Hardened stainless-steel fasteners should not be used with steel framing in environments with high humidity, condensation or other moisture that will be present at the dissimilar-metal interface.

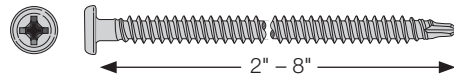

Type 410 Stainless Steel

Diameter (in.)	Length (in.)	Threads Per Inch	Head Diameter (in.)	Thread Length (in.)	Carton Quantity	Model No.
0.235	2	15½	0.438	Full	10	F14C200T10
0.235	3	15½	0.438	Full	10	F14C300T10
0.235	4	15½	0.438	¾	10	F14C400T10
0.235	4	15½	0.438	¾	100	F14400TIPC
0.235	5	15½	0.438	¾	10	F14C500T10
0.235	6	15½	0.438	¾	5	F14C600T5
0.235	6	15½	0.438	¾	100	F14600TIPC
0.235	7	15½	0.438	¾	5	F14C700T5
0.235	8	15½	0.438	¾	1	F14C800TIP1

Self-Drilling Wafer-Head Screw with Wings

Common Application:

Attach plywood and OSB panels to steel studs

Features:

- #2 Phillips drive
- Machine-screw thread, threaded full length
- Wings above drill point provide clearance hole in work piece so it won't climb up the shank and break off as point engages the steel substrate
- #3 drill point
- Type 410 stainless steel is coated for additional corrosion protection
- Type 410 stainless steel can be hardened through heat treatment, giving it the ability to drill through metal. It does not offer the same level of corrosion resistance of either Type 316 or 305 stainless steel.
- **Warning:** Hardened stainless-steel fasteners should not be used with steel framing in environments with high humidity, condensation or other moisture that will be present at the dissimilar-metal interface.

For more information on drilling thickness capacities and drill speed recommendations see pages 23-24.

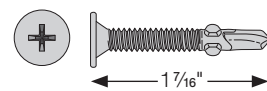

Type 410 Stainless Steel

Size	Length (in.)	Threads Per Inch	Head Diameter (in.)	Carton Quantity	Model No.
#10	1 7/16	24	0.450	100	F10C144WDC
#10	1 7/16	24	0.450	1000	F10C144WDM
#10	1 7/16	24	0.450	4500	F10C144WDB

Metal Screws

Self-Drilling Wire-Lath Modified Truss-Head Screw

Common Application:

Metal lath to steel studs; Corrugated siding panels to steel studs

Features:

- Fasten corrugated siding panels to steel stud without pre-drilling. Securely fastens one to three panel thicknesses
- #2 Phillips drive
- #2 drill point for quick penetration of aluminum panels without “point walking”
- Type 410 stainless steel is coated for additional corrosion protection
- Type 410 stainless steel can be hardened through heat treatment, giving it the ability to drill through metal. It does not offer the same level of corrosion resistance of either Type 316 or 305 stainless steel.
- **Warning:** Hardened stainless-steel fasteners should not be used with steel framing in environments with high humidity, condensation or other moisture that will be present at the dissimilar-metal interface.

For more information on drilling thickness capacities and drill speed recommendations see pages 23-24.

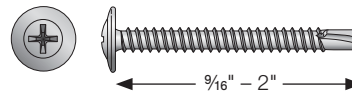

Type 410 Stainless Steel

Size	Length (in.)	Threads Per Inch	Head Diameter (in.)	Carton Quantity	Model No.
#8	1/16	18	0.423	100	F08T056KDC
#8	1/16	18	0.423	1000	F08T056KDM
#8	1/16	18	0.423	8000	F08T056KDB
#8	3/4	18	0.423	100	F08T075KDC
#8	3/4	18	0.423	1000	F08T075KDM
#8	3/4	18	0.423	6000	F08T075KDB
#8	1 1/4	18	0.423	100	F08T125KDC
#8	1 1/4	18	0.423	1000	F08T125KDM
#8	1 1/4	18	0.423	4000	F08T125KDB
#8	1 5/8	18	0.423	100	F08T162KDC
#8	1 5/8	18	0.423	1000	F08T162KDM
#8	1 5/8	18	0.423	3000	F08T162KDB
#8	2	18	0.423	100	F08T200KDC
#8	2	18	0.423	1000	F08T200KDM
#8	2	18	0.423	2500	F08T200KDB

Parts and Accessories

Driver Bits

Our industrial-grade driver bits are specially designed for a secure fit with the recess of Simpson Strong-Tie® fasteners. Available in both square and six-lobe drive configurations, our bits will outperform sub-standard bits commonly prone to cam-out and stripping.

Driver Bits: 6-Lobe

Drive	Bit Length (in.)	Bit Type	Clam Shell Quantity	Model No.
T-15	2	2" Power Bits	3	BIT15T-2-RC3
T-20	2	2" Power Bits	3	BIT20T-2-RC3
T-25	2	2" Power Bits	3	BIT25T-2-RC3
T-27	2	2" Power Bits	3	BIT27T-2-RC3
T-30	2	2" Power Bits	3	BIT30T-2-RC3
T-40	1	1" Insert Bits	3	BIT40T-1-RC3
T-40	1¾	1¾" Power Bits	3	BIT40T-134-RC3



Driver Bits: Square Drive

Drive	Bit Length (in.)	Bit Type	Clam Shell Quantity	Model No.
#1 SQUARE	2	2" Power Bits	3	BIT1S-2-RC3
#2 SQUARE	2	2" Power Bits	3	BIT2S-2-RC3
#2U SQUARE	2	Undersized 2" Power Bits	3	BIT2SU-2-RC3
#3 SQUARE	2	2" Power Bits	3	BIT3S-2-RC3
#3U SQUARE	2	Undersized 2" Power Bits	3	BIT3SU-2-RC3



Custom Nail Worksheet

Instructions for Ordering Custom Nails

Simpson Strong-Tie offers a wide variety of custom-order nail options through our distribution network. Provide a print with complete specifications or complete this worksheet and have your Simpson Strong-Tie dealer send it to us for a price quote and lead time estimate; minimum quantities may apply. Call 800-999-5099 to find your closest dealer.

What is your Application? _____

Step 1: Choose Material

- | | |
|--|---|
| <input type="checkbox"/> Aluminum (Model No. SPEC NAIL NF) | <input type="checkbox"/> Type 304 Stainless Steel (Model No. SPEC NAIL 304SS) |
| <input type="checkbox"/> Copper (Model No. SPEC NAIL NF) | <input type="checkbox"/> Type 316 Stainless Steel (Model No. SPEC NAIL 316SS) |
| <input type="checkbox"/> Silicon Bronze (Model No. SPEC NAIL NF) | <input type="checkbox"/> Other
_____ |

Step 2: Choose Head Type

- | | |
|----------------------------------|---|
| <input type="checkbox"/> Brad | <input type="checkbox"/> Headless |
| <input type="checkbox"/> Casing | <input type="checkbox"/> Pyramid |
| <input type="checkbox"/> Clipped | <input type="checkbox"/> Other
_____ |

Step 3: Choose Head Surface

- | | |
|--|---|
| <input type="checkbox"/> Checker Pattern | <input type="checkbox"/> Flat / Smooth |
| <input type="checkbox"/> Circle Pattern | <input type="checkbox"/> Other
_____ |

Step 4: Specify Head Size (inches)

(Some head diameters not possible in some materials)

Step 5: Specify Length (inches)

(Length range 1/2" - 7")

Step 6: Specify Diameter (inches or gauge)

(Diameter range 0.049" - 0.238")

Step 7: Choose Shank Type

- | | |
|---------------------------------------|---|
| <input type="checkbox"/> Annular Ring | <input type="checkbox"/> Spiral |
| <input type="checkbox"/> Smooth | <input type="checkbox"/> Other
_____ |

Step 8: Choose Point Type

- | | |
|----------------------------------|---|
| <input type="checkbox"/> Chisel | <input type="checkbox"/> Sheared |
| <input type="checkbox"/> Diamond | <input type="checkbox"/> Other
_____ |

Step 9: Choose Color / Finish (Optional)

- | | |
|----------------------------------|---|
| <input type="checkbox"/> Brown | <input type="checkbox"/> Tan |
| <input type="checkbox"/> Gray | <input type="checkbox"/> White |
| <input type="checkbox"/> Redwood | <input type="checkbox"/> Passivated |
| <input type="checkbox"/> Sienna | <input type="checkbox"/> Other
_____ |

Step 10: Choose Washer Type and size (Optional)

- | | |
|---|--|
| <input type="checkbox"/> EPDM | <input type="checkbox"/> Stainless Washer with bonded EPDM |
| <input type="checkbox"/> 3/8" | <input type="checkbox"/> 5/8" |
| <input type="checkbox"/> 5/8" | <input type="checkbox"/> 1 1/8" |
| <input type="checkbox"/> Other
_____ | <input type="checkbox"/> Other
_____ |

Step 11: Choose Packaging

- | | |
|------------------------------------|---|
| <input type="checkbox"/> 1 lb. Box | <input type="checkbox"/> 25 lb. Bucket |
| <input type="checkbox"/> 5 lb. Box | <input type="checkbox"/> Other
_____ |

Fasteners will be manufactured to the tolerances specified in ASTM F1667 unless otherwise specified.

Collated Nails and Staples



Siding/Fencing/Trim Nails

0° Inserted Plastic Coil, Full Round Head, Ring-Shank Nail

Features:

- Checker pattern on head blends with the wood grain, reduces glare from sunlight and accepts surface finishes
- Annular ring-shank increases withdrawal resistance to provide a secure attachment
- Available in Type 304 and aluminum

Compatible Pneumatic Tools

If you don't see your particular model in the table below, see pages 165-170 or call Simpson Strong-Tie and a sales professional will assist with fastener selection. (800) 999-5099

Duo-Fast® KDN50, RCN60, RCN70, CNP-60Y, CNP-65Y, DF225C

Spotnails® QCND65

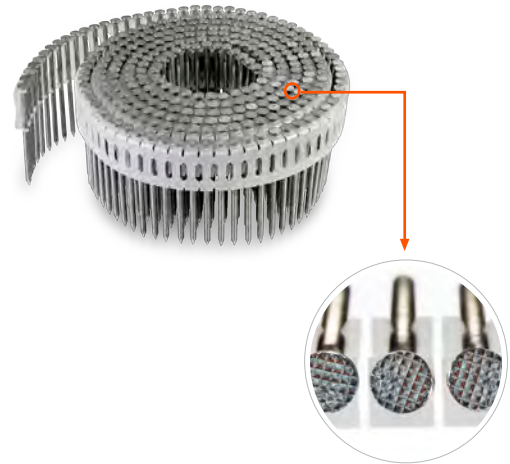

Type 304 Stainless Steel

Penny Size	Length (in.)	Shank Diameter (in.)	Head Diameter (in.)	Carton Quantity	Model No.
5d	1¾	0.099	0.210	9000	S12A175DNB*
7d	2¼	0.099	0.210	7200	S12A225DNB
7d	2¼	0.099	0.210	1200	S12A225DNBP

* These nails are special-order, non-stock items and are subject to minimum order quantities and longer lead times. Call Simpson Strong-Tie for details.

Aluminum

Penny Size	Length (in.)	Shank Diameter (in.)	Head Diameter (in.)	Carton Quantity	Model No.
—	1⅞	0.099	0.210	9000	A12A187DNB
7d	2¼	0.099	0.210	7200	A12A225DNB*

* These nails are special-order, non-stock items and are subject to minimum order quantities and longer lead times. Call Simpson Strong-Tie for details.

Siding/Fencing/Trim Nails

15° Inserted Plastic Coil, Full Round Head, Ring-Shank Nail

Features:

- Checker pattern on head blends with the wood grain, reduces glare from sunlight and accepts surface finishes
- Annular ring-shank increases withdrawal resistance to provide a secure attachment
- Choose Type 316 stainless steel for seaside applications and superior corrosion resistance

Compatible Pneumatic Tools

If you don't see your particular model in the table below, see pages 165-170 or call Simpson Strong-Tie and a sales professional will assist with fastener selection. (800) 999-5099

Bostitch® N64C, N66C, N75C

Grip-Rite® GRTCS250

Hitachi® NV65AH, NV75AG

Max® CN550S (up to 2"), CN565S, CN565

Senco® SCN49



Type 316 Stainless Steel

Penny Size	Length (in.)	Shank Diameter (in.)	Head Diameter (in.)	Carton Quantity	Model No.
4d	1½	0.092	0.221	3200	T13A150IPC
5d	1¾	0.092	0.221	3200	T13A175IPC
6d	2	0.092	0.221	3200	T13A200IPC
7d	2¼	0.092	0.221	2400	T13A225IPC
8d	2½	0.092	0.221	2400	T13A250IPC
4d	1½	0.092	0.221	600	T13A150IPBP
5d	1¾	0.092	0.221	600	T13A175IPBP
6d	2	0.092	0.221	600	T13A200IPBP
7d	2¼	0.092	0.221	600	T13A225IPBP
8d	2½	0.092	0.221	600	T13A250IPBP

Type 304 Stainless Steel

Penny Size	Length (in.)	Shank Diameter (in.)	Head Diameter (in.)	Carton Quantity	Model No.
4d	1½	0.092	0.221	3200	S13A150IPC
5d	1¾	0.092	0.221	3200	S13A175IPC
6d	2	0.092	0.221	3200	S13A200IPC
7d	2¼	0.092	0.221	2400	S13A225IPC
8d	2½	0.092	0.221	2400	S13A250IPC
7d	2¼	0.092	0.221	600	S13A225IPBP
8d	2½	0.092	0.221	600	S13A250IPBP

Siding/Fencing/Trim Nails

15° Inserted Plastic Coil, White Full Round Head, Ring-Shank Nail

Features:

- Checker pattern on head blends with the wood grain, reduces glare from sunlight and accepts surface finishes
- Annular ring-shank increases withdrawal resistance to provide a secure attachment
- Choose Type 316 stainless steel for seaside applications and superior corrosion resistance

Compatible Pneumatic Tools

If you don't see your particular model in the table below, see pages 165-170 or call Simpson Strong-Tie and a sales professional will assist with fastener selection. (800) 999-5099

Bostitch® N64C, N66C, N75C

Grip-Rite® GRTCS250

Hitachi® NV65AH, NV75AG

Max® CN550S (up to 2"), CN565S, CN565

Senco® SCN49



Type 304 Stainless Steel

Penny Size	Length (in.)	Shank Diameter (in.)	Head Diameter (in.)	Carton Quantity	Model No.
8d	2½	0.092	0.221	600	S13A250IPWBP

○
WHITE

Siding/Fencing/Trim Nails

15° Wire Coil, Full Round Head, Ring-Shank Siding Nail

Features:

- Checker pattern on heads blends with wood grain, reduces glare from sunlight and accepts surface finishes
- Generous under-head fillet allows nails to be driven flush, or countersunk, without crushing surrounding wood
- Annular ring-shank increases withdrawal resistance to provide a secure attachment that reduces cupping of siding boards
- Slender gauge and diamond point for easier driving
- Choose Type 316 stainless steel for seaside applications and superior corrosion resistance

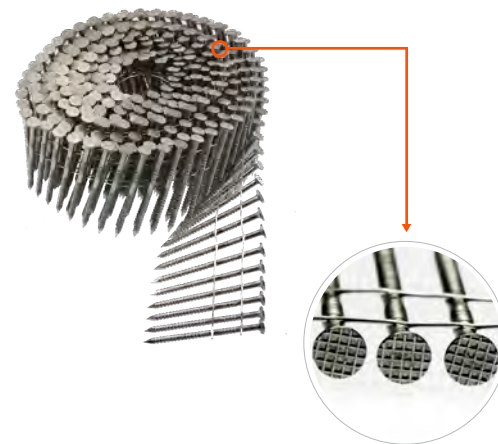

Compatible Pneumatic Tools

If you don't see your particular model in the table below, see pages 165-170 or call Simpson Strong-Tie and a sales professional will assist with fastener selection. (800) 999-5099

Bostitch®	N64C, N66C, N75C
Duo-Fast®	P275C
Grip-Rite®	GRTCS250
Hitachi®	NV65AH, NV75AG
Max®	CN55, CN665, CN565, CN565S, CN550S (up to 2")
Senco®	SCN60XP, SCN49, SCN 65XP, Pallet Pro57F (up to 2¼")

Type 316 Stainless Steel

Penny Size	Length (in.)	Shank Diameter (in.)	Head Diameter (in.)	Carton Quantity	Model No.
4d	1½	0.092	0.221	1800	T13A150SNJ
5d	1¾	0.092	0.221	1800	T13A175SNJ
6d	2	0.092	0.221	1800	T13A200SNJ
7d	2¼	0.092	0.221	1800	T13A225SNJ
8d	2½	0.092	0.221	1800	T13A250SNJ

Type 304 Stainless Steel

Penny Size	Length (in.)	Shank Diameter (in.)	Head Diameter (in.)	Carton Quantity	Model No.
3d	1¼	0.092	0.221	3600	S13A125SNC
3d	1¼	0.092	0.221	1500	S13A125SNBP
4d	1½	0.092	0.221	3600	S13A150SNC
4d	1½	0.092	0.221	1500	S13A150SNBP
5d	1¾	0.092	0.221	3600	S13A175SNC
5d	1¾	0.092	0.221	1200	S13A175SNBP
6d	2	0.092	0.221	3600	S13A200SNC
6d	2	0.092	0.221	1200	S13A200SNBP
7d	2¼	0.092	0.221	3600	S13A225SNC
7d	2¼	0.092	0.221	900	S13A225SNBP
8d	2½	0.092	0.221	3600	S13A250SNC
8d	2½	0.092	0.221	900	S13A250SNBP

Siding/Fencing/Trim Nails

15° Wire Coil, Painted Full Round Head, Ring-Shank Nail

Features:

- Checker pattern on heads blends with wood grain, reduces glare from sunlight and accepts surface finishes
- Durable painted finish helps heads blend with siding material
- Annular ring-shank increases withdrawal resistance to provide a secure attachment that reduces cupping of siding boards
- Slender gauge and diamond point for easier driving

Compatible Pneumatic Tools

If you don't see your particular model in the table below, see pages 165-170 or call Simpson Strong-Tie and a sales professional will assist with fastener selection. (800) 999-5099

Bostitch®	N64C, N66C, N75C
Duo-Fast®	P275C
Grip-Rite®	GRTCS250
Hitachi®	NV65AH, NV75AG
Max®	CN55, CN665, CN565, CN565S, CN550S (up to 2")
Senco®	SCN60XP, SCN49, SCN 65XP, Pallet Pro57F (up to 2¼")

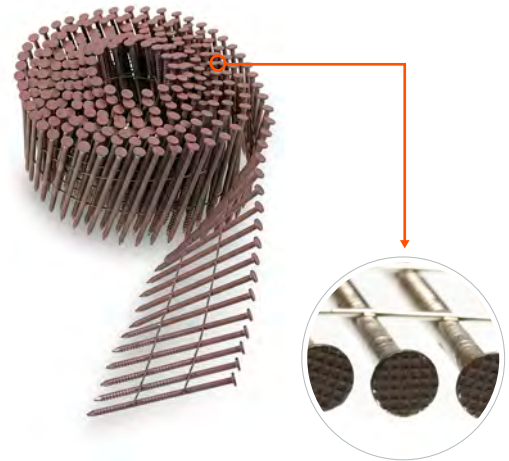

Type 304 Stainless Steel

Penny Size	Length (in.)	Shank Diameter (in.)	Head Diameter (in.)	Color	Carton Quantity	Model No.
6d	2	0.092	0.221	—	1200	S13A200WWCBP
6d	2	0.092	0.221	Dark Brown	3600	S13A200CCB
6d	2	0.092	0.221	Gray	3600	S13A200CCG
6d	2	0.092	0.221	Redwood	3600	S13A200CCR
6d	2	0.092	0.221	Tan	3600	S13A200CCT
6d	2	0.092	0.221	White	3600	S13A200CWH
7d	2¼	0.092	0.221	Dark Brown	3600	S13A225CCB
7d	2¼	0.092	0.221	White	3600	S13A225CWH
7d	2¼	0.092	0.221	Gray	3600	S13A225CCG
7d	2¼	0.092	0.221	Redwood	3600	S13A225CCR
7d	2¼	0.092	0.221	Tan	3600	S13A225CCT
7d	2¼	0.092	0.221	Sienna	3600	S13A225CCS
8d	2½	0.092	0.221	—	900	S13A250WWCBP
8d	2½	0.092	0.221	Dark Brown	3600	S13A250CCB
8d	2½	0.092	0.221	Gray	3600	S13A250CCG
8d	2½	0.092	0.221	Redwood	3600	S13A250CCR
8d	2½	0.092	0.221	Tan	3600	S13A250CCT
8d	2½	0.092	0.221	White	3600	S13A250CWH
8d	2½	0.092	0.221	Sienna	3600	S13A250CCS



Roofing Nails

15° Wire Coil, Full Round Head, Ring-Shank Roofing Nail

Features:

- Ideal for asphalt and synthetic slate roofing
- Large flat head, diamond point for easier driving
- Annular ring-shank increases withdrawal resistance to provide a secure attachment to OSB or plywood roof decks
- Choose Type 316 stainless steel for seaside applications and superior corrosion resistance

Compatible Pneumatic Tools

If you don't see your particular model in the table below, see pages 165-170 or call Simpson Strong-Tie and a sales professional will assist with fastener selection. (800) 999-5099

Bosch®	RN175
Bostitch®	RN46
Dewalt®	D51321
Grip-Rite®	GRTCR175
Hitachi®	NV45AB2, NV45AE
Makita®	AN453
Max®	CN445R, CN450R
Paslode®	R175-C, CR175C
Porter Cable®	RN175A
Ridgid®	R175RND
Senco®	RoofPro 455XP

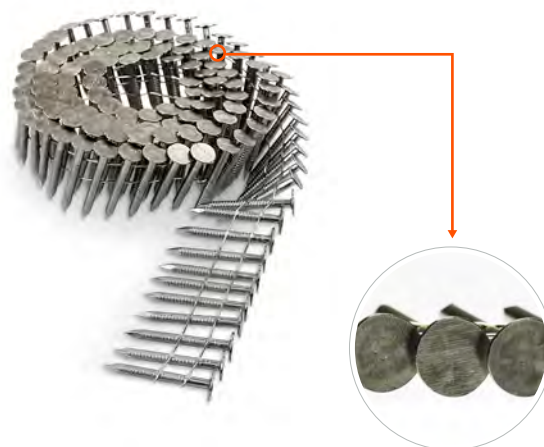

Type 316 Stainless Steel

Penny Size	Length (in.)	Shank Diameter (in.)	Head Diameter (in.)	Carton Quantity	Model No.
2d	1	0.120	3/8	3600	T11A100RNJ
3d	1¼	0.120	3/8	3600	T11A125RNJ
4d	1½	0.120	3/8	3600	T11A150RNJ
5d	1¾	0.120	3/8	3600	T11A175RNJ

Type 304 Stainless Steel

Penny Size	Length (in.)	Shank Diameter (in.)	Head Diameter (in.)	Carton Quantity	Model No.
2d	1	0.120	3/8	7200	S11A100RNB
3d	1¼	0.120	3/8	7200	S11A125RNB
3d	1¼	0.120	3/8	720	S11A125RNBP
3d	1¼	0.120	3/8	2400	S11A125RNJ
4d	1½	0.120	3/8	7200	S11A150RNB
4d	1½	0.120	3/8	600	S11A150RNBP
4d	1½	0.120	3/8	2400	S11A150RNJ
5d	1¾	0.120	3/8	7200	S11A175RNB
5d	1¾	0.120	3/8	480	S11A175RNBP
5d	1¾	0.120	3/8	2400	S11A175RNJ

Roofing Nails

15° Wire Coil, Full Round Head, Smooth-Shank Roofing Nail

Features:

- Ideal for asphalt and synthetic slate roofing
- Large flat head, diamond point for easier driving
- Annular ring-shank increases withdrawal resistance to provide a secure attachment to OSB or plywood roof decks
- Choose Type 316 stainless steel for seaside applications and superior corrosion resistance

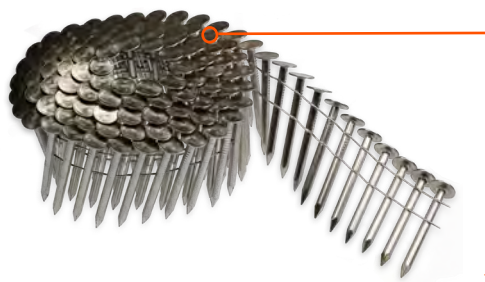

Compatible Pneumatic Tools

If you don't see your particular model in the table below, see pages 165-170 or call Simpson Strong-Tie and a sales professional will assist with fastener selection. (800) 999-5099

Bosch®	RN175
Bostitch®	RN46
Dewalt®	D51321
Grip-Rite®	GRTCR175
Hitachi®	NV45AB2, NV45AE
Makita®	AN453
Max®	CN445R, CN450R
Paslode®	R175-C, CR175C
Porter Cable®	RN175A
Ridgid®	R175RND
Senco®	RoofPro 455XP

Collated Nails and Staples

Type 316 Stainless Steel

Penny Size	Length (in.)	Shank Diameter (in.)	Head Diameter (in.)	Carton Quantity	Model No.
3d	1¼	0.120	¾	3600	T11N125RNJ
4d	1½	0.120	¾	3600	T11N150RNJ
5d	1¾	0.120	¾	3600	T11N175RNJ

Type 304 Stainless Steel

Penny Size	Length (in.)	Shank Diameter (in.)	Head Diameter (in.)	Carton Quantity	Model No.
—	¾	0.120	¾	7200	S11N075RNB
—	7⁄8	0.120	¾	7200	S11N087RNB
2d	1	0.120	¾	7200	S11N100RNB
2d	1	0.120	¾	2400	S11N100RNJ
3d	1¼	0.120	¾	7200	S11N125RNB
3d	1¼	0.120	¾	2400	S11N125RNJ
4d	1½	0.120	¾	7200	S11N150RNB
4d	1½	0.120	¾	2400	S11N150RNJ
5d	1¾	0.120	¾	7200	S11N175RNB
5d	1¾	0.120	¾	2400	S11N175RNJ

Framing Nails – Wire Coil

15° Wire Coil, Full Round Head, Ring-Shank Decking/Framing Nail

Features:

- Checker pattern on head blends with the wood grain, reduces glare from sunlight and accepts surface finishes.
- Annular ring-shank increases withdrawal resistance to provide a secure attachment
- Choose Type 316 stainless steel for seaside applications and superior corrosion resistance

Compatible Pneumatic Tools

If you don't see your particular model in the table below, see pages 165-170 or call Simpson Strong-Tie and a sales professional will assist with fastener selection. (800) 999-5099

Bostitch®	N80CB (up to 3¼"), N75C (up to 3"), N89C
Dewalt®	D51855
Duo-Fast®	P350C/CNW90, P275C (up to 2¾")
Grip-Rite®	GRTC90-3½, GRTCS250 (up to 0.099", 2½")
Hitachi®	NV65AH (up to 0.099", 2½"), NV75AG (up to 3"), NV83A2
Makita®	AN901
Max®	CN565S (up to 2½", 0.099"), CN565D (up to 2½", 0.113"), CN665 (up to 2½"), CN890S, CN565 (up to 2½", 0.099"), CN100, CN70 (up to 2½"), CN80 (up to 3¼")
Senco®	SCN60XP (up to 2¾", 0.113"), SCN49 (up to 2½", 0.113"), SCN 65XP (up to 0.113"), PalletPro100, PalletPro130 (over 3"), PalletPro70 (up to 2¾", 0.113"), Pallet Pro83 (up to 3¼")

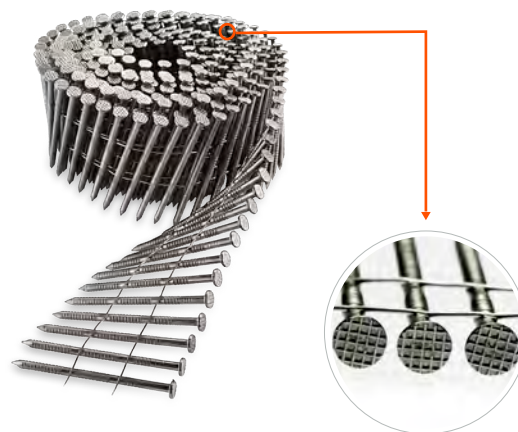

Type 316 Stainless Steel

Penny Size	Length (in.)	Shank Diameter (in.)	Head Diameter (in.)	Carton Quantity	Carton Weight (lb.)	Model No.
7d	2¼	0.099	¼	1800	10	T12A225PNJ
8d	2½	0.099	¼	1800	10	T12A250PNJ
8d	2½	0.099	¼	3600	31	T12A250PNB
6d	2	0.113	¼	3600	21	T12A200PNB
10d	3	0.120	17/64	1800	19	T11A300PNJ
10d	3	0.131	9/32	1800	24	T10A300PNJ
12d	3¼	0.120	17/64	1800	20	T11A325PNJ
16d	3½	0.131	9/32	1800	28	T10A350PNJ

Type 304 Stainless Steel

Penny Size	Length (in.)	Shank Diameter (in.)	Head Diameter (in.)	Carton Quantity	Carton Weight (lb.)	Model No.
3d	1¼	0.120	3/8	720	5	S11A125RNB
4d	1½	0.099	¼	3600	14	S12A150PNB
4d	1½	0.120	3/8	600	5	S11A150RNB
5d	1¾	0.099	¼	3600	15	S12A175PNB
5d	1¾	0.120	3/8	480	5	S11A175RNB
6d	2	0.099	¼	3600	17	S12A200PNB
8d	2½	0.099	¼	3600	21	S12A250PNB
8d	2¾	0.113	¼	3600	26	S12A237PNB
10d	3	0.099	¼	1800	14	S12A300PNJ
10d	3	0.120	17/64	1800	19	S11A300PNJ
10d	3	0.131	9/32	1800	24	S10A300PNJ
12d	3¼	0.120	17/64	1800	20	S11A325PNJ
12d	3¼	0.131	9/32	1800	26	S10A325PNJ

Framing Nails – Wire Coil

15° Wire Coil, Painted Full Round Head, Ring-Shank Decking/Framing Nail

Features:

- Checker pattern on head blends with the wood grain, reduces glare from sunlight and accepts surface finishes.
- Annular ring-shank increases withdrawal resistance to provide a secure attachment

Compatible Pneumatic Tools

If you don't see your particular model in the table below, see pages 165-170 or call Simpson Strong-Tie and a sales professional will assist with fastener selection. (800) 999-5099

Bostitch®	N80CB (up to 3¼"), N75C (up to 3"), N89C
Dewalt®	D51855
Duo-Fast®	P350C/CNW90, P275C (up to 2¾")
Grip-Rite®	GRTC90-3½, GRTCS250 (up to 0.099", 2½")
Hitachi®	NV65AH (up to 0.099", 2½"), NV75AG (up to 3"), NV83A2
Makita®	AN901
Max®	CN565S (up to 2½", 0.099"), CN565D (up to 2½", 0.113"), CN665 (up to 2½"), CN890S, CN565 (up to 2½", 0.099"), CN100, CN70 (up to 2½"), CN80 (up to 3¼")
Senco®	SCN60XP (up to 2¾", 0.113"), SCN49 (up to 2½", 0.113"), SCN 65XP (up to 0.113"), PalletPro100, PalletPro130 (over 3"), PalletPro70 (up to 2¾", 0.113"), Pallet Pro83 (up to 3¼")



Type 304 Stainless Steel

Penny Size	Length (in.)	Shank Diameter (in.)	Head Diameter (in.)	Color	Carton Quantity	Model No.
10d	3	0.120	17/64	Dark Brown	1800	S11A300PJB
10d	3	0.120	17/64	Gray	1800	S11A300PJG
10d	3	0.120	17/64	Redwood	1800	S11A300PJR
10d	3	0.120	17/64	Tan	1800	S11A300PJT
12d	3¼	0.120	17/64	Dark Brown	1800	S11A325PJB
12d	3¼	0.120	17/64	Gray	1800	S11A325PJG
12d	3¼	0.120	17/64	Redwood	1800	S11A325PJR
12d	3¼	0.120	17/64	Tan	1800	S11A325PJT



Framing Nails – Plastic Strip

20-22° Plastic Strip, Casing Head, Ring-Shank Nail

Features:

- Countersunk casing head
- Durable painted finish helps heads blend with decking and siding material
- Checker pattern on heads blends with the wood grain
- Annular ring-shank increases withdrawal resistance to provide a secure attachment

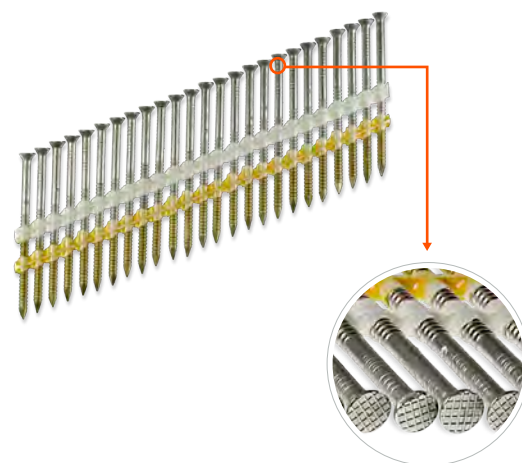

Compatible Pneumatic Tools

If you don't see your particular model in the table below, see pages 165-170 or call Simpson Strong-Tie and a sales professional will assist with fastener selection. (800) 999-5099

Bosch®	SN350-20F (up to 0.148")
Bostitch®	F21PL
Dewalt®	D51850 (up to 0.148"), D51844 (up to 0.148")
Grip-Rite®	GRTRFR83 (up to 0.131", 3/4"), GRTRH350 (up to 0.148")
Hitachi®	NR83AS (up to 0.131", 3/4"), NR90AC3, NR90AEPR (up to 0.148"), NR90GR (up to 0.131"), NR90GR2 (up to 0.131")
Makita®	AN923
Max®	SN883RH (up to 0.148", 3/4"), SN883RH2 (up to 0.148", 3/4"), SN890RH (up to 0.148")
Porter Cable®	FR350MAG, FR350A (up to 0.148")
Ridgid®	R350RHA
Senco®	SN902XP (up to 0.148", 3/4"), SN952XP (up to 0.148"), GT90FRH (up to 0.131"), FramePro 602 (up to 0.148"), FramePro 702XP (up to 0.148"), FramePro 752XP

Type 304 Stainless Steel

Penny Size	Length (in.)	Shank Diameter (in.)	Head Diameter (in.)	Color	Carton Quantity	Model No.
8d	2 3/8	0.120	1/4	None	1000	S11A237KDJ
8d	2 3/8	0.120	1/4	Brown	1000	S11A237KJB
8d	2 3/8	0.120	1/4	Gray	1000	S11A237KJG
8d	2 3/8	0.120	1/4	Redwood	1000	S11A237KJR
8d	2 3/8	0.120	1/4	Sienna	1000	S11A237KJS
8d	2 3/8	0.120	1/4	Tan	1000	S11A237KJT
12d	3 1/4	0.131	1/4	None	1000	S10A325KDJ
12d	3 1/4	0.131	1/4	Brown	1000	S10A325KJB
12d	3 1/4	0.131	1/4	Gray	1000	S10A325KJG
12d	3 1/4	0.131	1/4	Redwood	1000	S10A325KJR
12d	3 1/4	0.131	1/4	Sienna	1000	S10A325KJS
12d	3 1/4	0.131	1/4	Tan	1000	S10A325KJT



Collated Nails and Staples

Framing Nails – Plastic Strip

20-22° Plastic Strip, Full Round Head, Ring-Shank Nail

Features:

- Checker pattern on heads blends with the wood grain, reduces glare from sunlight and accepts surface finishes
- Annular ring-shank increases withdrawal resistance to provide a secure attachment
- Choose Type 316 stainless steel for seaside applications and superior corrosion resistance

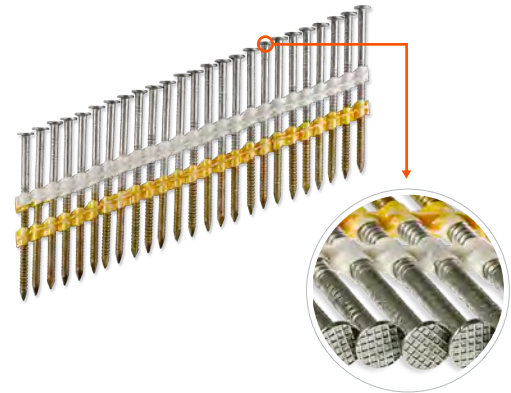

Compatible Pneumatic Tools

If you don't see your particular model in the table below, see pages 165-170 or call Simpson Strong-Tie and a sales professional will assist with fastener selection. (800) 999-5099

Bosch®	SN350-20F (up to 0.148")	Makita®	AN923
Bostitch®	F21PL	Max®	SN883RH (up to 0.148", 3/4"), SN883RH2 (up to 0.148", 3/4") SN890RH (up to 0.148")
Dewalt®	D51850 (up to 0.148"), D51844 (up to 0.148")	Porter Cable®	FR350MAG, FR350A (up to 0.148")
Grip-Rite®	GRTFR83 (up to 0.131", 3/4"), GRTRH350 (up to 0.148")	Ridgid®	R350RHA
Hitachi®	NR83AS (up to 0.131", 3/4"), NR90AC3, NR90AEPR (up to 0.148"), NR90GR (up to 0.131"), NR90GR2 (up to 0.131")	Senco®	SN902XP (up to 0.148", 3/4"), SN952XP (up to 0.148"), GT90FRH (up to 0.131") FramePro 602 (up to 0.148"), FramePro 702XP (up to 0.148"), FramePro 752XP

Type 316 Stainless Steel

Penny Size	Length (in.)	Shank Diameter (in.)	Head Diameter (in.)	Carton Quantity	Model No.
6d	2	0.113	9/32	5000	T12A200CNB
6d	2	0.113	9/32	1000	T12A200CNJ
8d	2 3/8	0.113	9/32	5000	T12A237CNB
8d	2 3/8	0.113	9/32	1000	T12A237CNJ
8d	2 1/2	0.120	9/32	4000	T11A250CNB
8d	2 1/2	0.120	9/32	1000	T11A250CNJ
10d	3	0.120	9/32	4000	T11A300CNB
10d	3	0.120	9/32	1000	T11A300CNJ
10d	3	0.131	9/32	4000	T10A300CNB
10d	3	0.131	9/32	1000	T10A300CNJ
12d	3 1/4	0.120	9/32	4000	T11A325CNB
12d	3 1/4	0.120	9/32	1000	T11A325CNJ
12d	3 1/4	0.131	9/32	4000	T10A325CNB
12d	3 1/4	0.131	9/32	1000	T10A325CNJ
16d	3 1/2	0.131	9/32	4000	T10A350CNB
16d	3 1/2	0.131	9/32	1000	T10A350CNJ

Type 304 Stainless Steel

Penny Size	Length (in.)	Shank Diameter (in.)	Head Diameter (in.)	Carton Quantity	Model No.
6d	2	0.113	9/32	5000	S12A200CNB
6d	2	0.113	9/32	1000	S12A200CNJ
6d	2	0.120	9/32	5000	S11A200CNB
6d	2	0.120	9/32	1000	S11A200CNJ
7d	2 1/4	0.148	9/32	1000	S9A225CNJ
8d	2 3/8	0.113	9/32	5000	S12A237CNB
8d	2 3/8	0.113	9/32	1000	S12A237CNJ
8d	2 1/2	0.120	9/32	4000	S11A250CNB
8d	2 1/2	0.120	9/32	1000	S11A250CNJ
8d	2 1/2	0.131	9/32	4000	S10A250CNB
10d	3	0.120	9/32	4000	S11A300CNB
10d	3	0.120	9/32	1000	S11A300CNJ
10d	3	0.131	9/32	4000	S10A300CNB
10d	3	0.131	9/32	1000	S10A300CNJ
12d	3 1/4	0.120	9/32	4000	S11A325CNB
12d	3 1/4	0.120	9/32	1000	S11A325CNJ
12d	3 1/4	0.131	9/32	4000	S10A325CNB
12d	3 1/4	0.131	9/32	1000	S10A325CNJ
16d	3 1/2	0.131	9/32	4000	S10A350CNB
16d	3 1/2	0.131	9/32	1000	S10A350CNJ

Framing Nails – Plastic Strip

20-22° Plastic Strip, Full Round Head, Screw-Shank Nail

Features:

- Smooth head
- Screw shank increases withdrawal resistance to provide a secure attachment
- Choose Type 316 stainless steel for seaside applications and superior corrosion resistance

Compatible Pneumatic Tools

If you don't see your particular model in the table below, see pages 165-170 or call Simpson Strong-Tie and a sales professional will assist with fastener selection. (800) 999-5099

Bosch®	SN350-20F (up to 0.148")
Bostitch®	F21PL
Dewalt®	D51850 (up to 0.148"), D51844 (up to 0.148")
Grip-Rite®	GRTRFR83 (up to 0.131", 3/4"), GRTRH350 (up to 0.148")
Hitachi®	NR83AS (up to 0.131", 3/4"), NR90AC3, NR90AEPR (up to 0.148"), NR90GR (up to 0.131"), NR90GR2 (up to 0.131")
Makita®	AN923
Max®	SN883RH (up to 0.148", 3/4"), SN883RH2 (up to 0.148", 3/4"), SN890RH (up to 0.148")
Porter Cable®	FR350MAG, FR350A (up to 0.148")
Ridgid®	R350RHA
Senco®	SN902XP (up to 0.148", 3/4"), SN952XP (up to 0.148"), GT90FRH (up to 0.131"), FramePro 602 (up to 0.148"), FramePro 702XP (up to 0.148"), FramePro 752XP

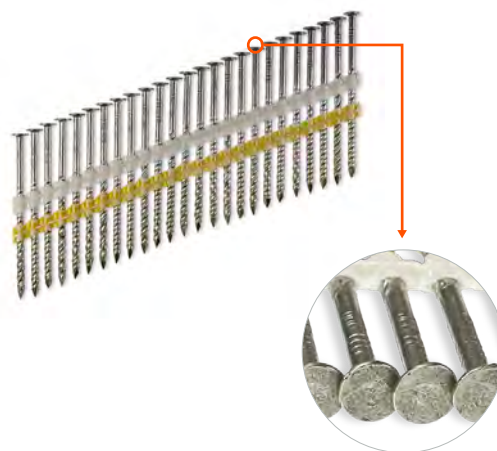

Collated Nails and Staples

Type 316 Stainless Steel

Penny Size	Length (in.)	Shank Diameter (in.)	Head Diameter (in.)	Carton Quantity	Model No.
6d	2	0.113	9/32	5000	T12S200CNB
6d	2	0.113	9/32	1000	T12S200CNJ
8d	2½	0.113	9/32	4000	T12S250CNB
8d	2½	0.113	9/32	1000	T12S250CNJ
10d	3	0.120	9/32	4000	T11S300CNB
10d	3	0.120	9/32	1000	T11S300CNJ
12d	3¼	0.120	9/32	4000	T11S325CNB
12d	3¼	0.120	9/32	1000	T11S325CNJ
16d	3½	0.131	9/32	4000	T10S350CNB*
16d	3½	0.131	9/32	1000	T10S350CNJ*

*These nails are special-order, non-stock items and are subject to minimum order quantities and longer lead times. Please call Simpson Strong-Tie for details (800) 999-5099.

Type 304 Stainless Steel

Penny Size	Length (in.)	Shank Diameter (in.)	Head Diameter (in.)	Carton Quantity	Model No.
6d	2	0.113	9/32	5000	S12S200CNB
6d	2	0.113	9/32	1000	S12S200CNJ
8d	2½	0.113	9/32	4000	S12S250CNB
8d	2½	0.113	9/32	1000	S12S250CNJ
10d	3	0.120	9/32	4000	S11S300CNB
10d	3	0.120	9/32	1000	S11S300CNJ
12d	3¼	0.120	9/32	4000	S11S325CNB
12d	3¼	0.120	9/32	1000	S11S325CNJ
16d	3½	0.131	9/32	4000	S10S350CNB
16d	3½	0.131	9/32	1000	S10S350CNJ

Framing Nails – Plastic Strip

20-22° Plastic Strip, Full Round Head, Smooth-Shank Nail

Features:

- Smooth head
- Choose Type 316 stainless steel for seaside applications and superior corrosion resistance

Compatible Pneumatic Tools

If you don't see your particular model in the table below, see pages 165-170 or call Simpson Strong-Tie and a sales professional will assist with fastener selection. (800) 999-5099

Bosch®	SN350-20F (up to 0.148")
Bostitch®	F21PL
Dewalt®	D51850 (up to 0.148"), D51844 (up to 0.148")
Grip-Rite®	GRTFR83 (up to 0.131", 3/4"), GRTRH350 (up to 0.148")
Hitachi®	NR83AS (up to 0.131", 3/4"), NR90AC3, NR90AEPR (up to 0.148"), NR90GR (up to 0.131"), NR90GR2 (up to 0.131")
Makita®	AN923
Max®	SN883RH (up to 0.148", 3/4"), SN883RH2 (up to 0.148", 3/4"), SN890RH (up to 0.148")
Porter Cable®	FR350MAG, FR350A (up to 0.148")
Ridgid®	R350RHA
Senco®	SN902XP (up to 0.148", 3/4"), SN952XP (up to 0.148"), GT90FRH (up to 0.131"), FramePro 602 (up to 0.148"), FramePro 702XP (up to 0.148"), FramePro 752XP

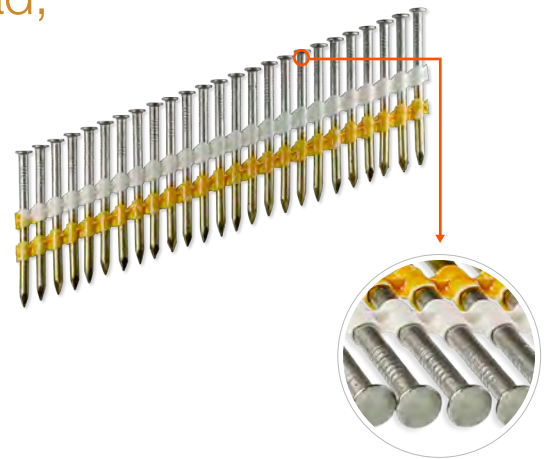

Type 316 Stainless Steel

Penny Size	Length (in.)	Shank Diameter (in.)	Head Diameter (in.)	Carton Quantity	Model No.
4d	1½	0.148	⅝	1000	T9N150JNJ

Type 304 Stainless Steel

Penny Size	Length (in.)	Shank Diameter (in.)	Head Diameter (in.)	Carton Quantity	Model No.
8d	2¾	0.113	⅝	5000	S12N237CNCB
8d	2¾	0.113	⅝	1000	S12N237CNCJ
8d	2¾	0.148	⅝	1000	S9N237CNCJ
10d	3	0.148	⅝	1000	S9N300CNCJ
16d	3½	0.162	⅝	1000	S8N350CNCJ

Framing Nails – Plastic Strip

31-34° Plastic Strip, Full Round Head, Ring-Shank Nail

Features:

- Checker pattern on heads blends with the wood grain, reduces glare from sunlight and accepts surface finishes
- Annular ring-shank increases withdrawal resistance to provide a secure attachment
- Choose Type 316 stainless steel for seaside applications and superior corrosion resistance

Compatible Pneumatic Tools

If you don't see your particular model in the table below, see pages 165-170 or call Simpson Strong-Tie and a sales professional will assist with fastener selection. (800) 999-5099

Bosch®	SN350-34C
Bostitch®	F33PT
DeWalt®	D51825, D51822
Grip-Rite®	GRTFC83 (up to 3¼"), GRTCH350
Hitachi®	NR83AA3 (up to 3¼"), NR90ADPR, NR90GC2
Makita®	AN943
Max®	SN883CH/34 (up to 3¼"), SN890CH/34
Paslode®	PF350S, CF325 (up to 3¼"), F350S, 900420 (up to 3¼")
Porter Cable®	FC350A
Ridgid®	R350CHA
Senco®	SN901XP (up to 3¼"), SN951XP, GT90CH, FramePro601, FramePro701XP

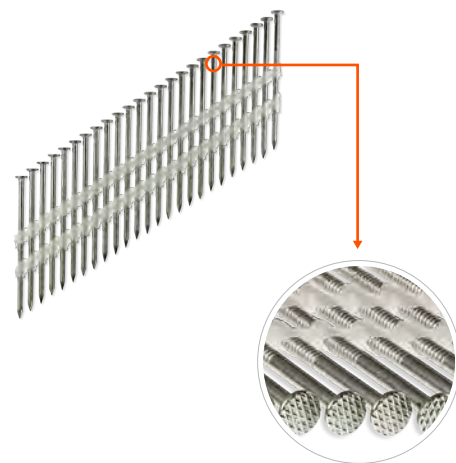

Type 316 Stainless Steel

Penny Size	Length (in.)	Shank Diameter (in.)	Head Diameter (in.)	Carton Quantity	Model No.
8d	2¾	0.113	⅝	4000	T12A237B31*
8d	2¾	0.113	⅝	1000	T12A237P31*
10d	3	0.120	⅝	4000	T11A300B31*
10d	3	0.120	⅝	1000	T11A300P31
12d	3¼	0.131	⅝	4000	T10A325B31*
12d	3¼	0.131	⅝	1000	T10A325P31

*These nails are special-order, non-stock items and are subject to minimum order quantities and longer lead times. Please call Simpson Strong-Tie for details (800) 999-5099.

Type 304 Stainless Steel

Penny Size	Length (in.)	Shank Diameter (in.)	Head Diameter (in.)	Carton Quantity	Model No.
8d	2¾	0.113	⅝	4000	S12A237B31*
8d	2¾	0.113	⅝	1000	S12A237P31
10d	3	0.120	⅝	4000	S11A300B31
10d	3	0.120	⅝	1000	S11A300P31
12d	3¼	0.131	⅝	4000	S10A325B31*
12d	3¼	0.131	⅝	1000	S10A325P31*

*These nails are special-order, non-stock items and are subject to minimum order quantities and longer lead times. Please call Simpson Strong-Tie for details (800) 999-5099.

Framing Nails – Wire Weld

28° Wire-Weld, Clipped Head, Ring-Shank Nail

Features:

- Smooth head
- Annular ring-shank increases withdrawal resistance to provide a secure attachment

Compatible Pneumatic Tools

If you don't see your particular model in the table below, see pages 165-170 or call Simpson Strong-Tie and a sales professional will assist with fastener selection. (800) 999-5099

Bostitch®	F28WW, GF28WW, N100S
Grip-Rite®	GRTFW83
Hitachi®	NR90AF
Max®	SN883CH/28, SN890CH/28

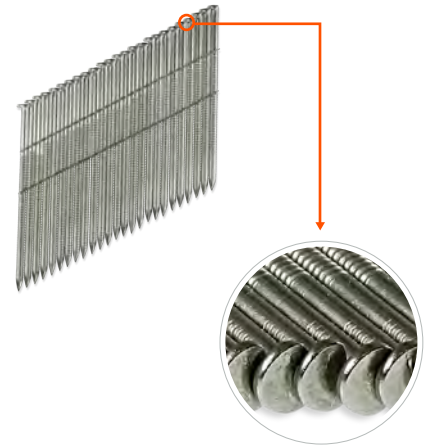

Type 304 Stainless Steel

Penny Size	Length (in.)	Shank Diameter (in.)	Carton Quantity	Model No.
8d	2¾	0.113	1000	S12A237W28
10d	3	0.120	1000	S11A300W28
12d	3¼	0.131	1000	S10A325W28

Framing Nails – Paper Tape

31-34° Paper Tape, Clipped Head, Ring-Shank Nail

Features:

- Smooth head
- Annular ring-shank increases withdrawal resistance to provide a secure attachment
- Choose Type 316 stainless steel for seaside applications and superior corrosion resistance

Compatible Pneumatic Tools

If you don't see your particular model in the table below, see pages 165-170 or call Simpson Strong-Tie and a sales professional will assist with fastener selection. (800) 999-5099

Bosch®	SN350-34C
Bostitch®	F33PT
DeWalt®	D51825, D51822
Grip-Rite®	GRTFC83 (up to 3¼"), GRTCH350
Hitachi®	NR83AA3 (up to 3¼"), NR90ADPR, NR90GC2
Makita®	AN943
Max®	SN883CH/34 (up to 3¼"), SN890CH/34
Paslode®	PF350S, CF325 (up to 3¼"), F350S, 900420 (up to 3¼")
Porter Cable®	FC350A
Ridgid®	R350CHA
Senco®	SN901XP (up to 3¼"), SN951XP, GT90CH, FramePro601, FramePro701XP

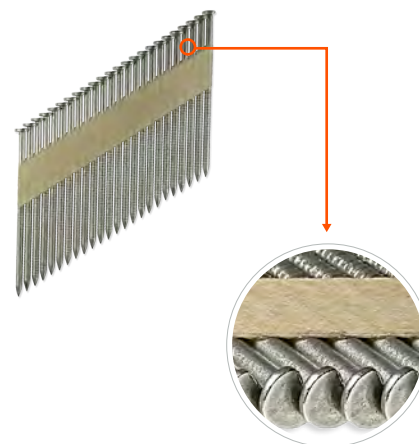

Type 316 Stainless Steel

Penny Size	Length (in.)	Shank Diameter (in.)	Carton Quantity	Model No.
6d	2	0.113	1000	T12A200T31*
8d	2¾	0.113	1000	T12A237T31
10d	3	0.120	1000	T11A300T31
12d	3¼	0.131	1000	T10A325T31

*These nails are special-order, non-stock items and are subject to minimum order quantities and longer lead times. Please call Simpson Strong-Tie for details (800) 999-5099.

Type 304 Stainless Steel

Penny Size	Length (in.)	Shank Diameter (in.)	Carton Quantity	Model No.
6d	2	0.113	1000	S12A200T31
8d	2¾	0.113	1000	S12A237T31
10d	3	0.120	1000	S11A300T31
12d	3¼	0.131	1000	S10A325T31
16d	3½	0.131	1000	S10A350T31

*These nails are special-order, non-stock items and are subject to minimum order quantities and longer lead times. Please call Simpson Strong-Tie for details (800) 999-5099.

Connector Nails

Strong-Drive® 33° SCN SMOOTH-SHANK CONNECTOR Nail

Features:

- 33° collation angle
- Full round head
- Smooth head

For Technical Data and Loads, see page 325

Compatible Pneumatic Tools

If you don't see your particular model in the table below, see pages 165-170 or call Simpson Strong-Tie and a sales professional will assist with fastener selection. (800) 999-5099

Bostitch®	MCN150 (up to 1½"), MCN250, F33PT
Grip-Rite®	GR150 (up to 1½"), GRSB150-1½ (up to 1½"), GR250, GRSB250-2½,
Hitachi®	NR65AK
Paslode®	PF150S-PP (up to 1½"), F250S-PP
Senco®	HN150 (up to 1½"), HN250

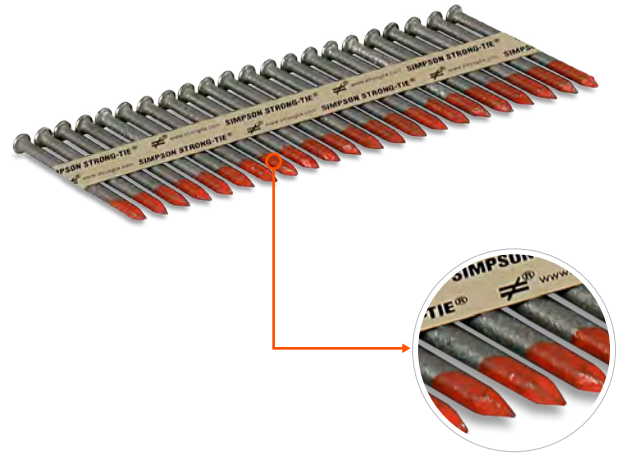

Hot-Dip Galvanized

Length (in.)	Shank Diameter (in.)	Head Diameter (in.)	Carton Quantity	Model No.
1½	0.131	0.285	500	N8HDGPT500
2½	0.131	0.285	500	8DHDGPT500
1½	0.148	0.285	500	N10HDGPT500
2½	0.148	0.285	500	N10DHDGPT500
2½	0.162	0.285	500	N16HDGPT500

Hot-dip Galvanized per ASTM A153.

Strong-Drive® 33° SCNR RING-SHANK CONNECTOR Nail

Features:

- 33° collation angle
- Full round head

For Technical Data and Loads, see page 324

Compatible Pneumatic Tools

See above.

If you don't see your particular model in the table below, see pages 165-170 or call Simpson Strong-Tie and a sales professional will assist with fastener selection. (800) 999-5099

Type 316 Stainless Steel

Length (in.)	Shank Diameter (in.)	Head Diameter (in.)	Carton Quantity	Model No.
1½	0.148	⅜	1500	T9A150MCN
2½	0.148	⅜	1000	T9A250MCN

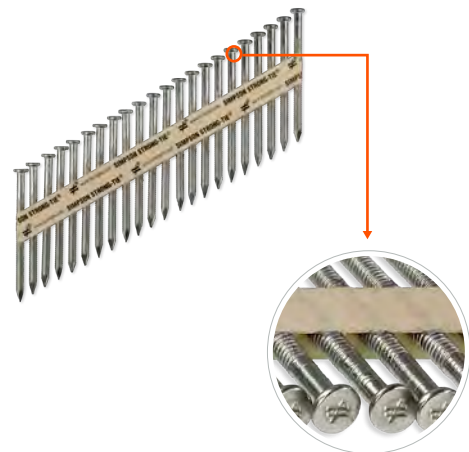

Trim Nails

20° Angle, Adhesive Collation, T-Style Head, 16-Gauge Finishing Nail

Features:

- T-style head minimizes the nail head size for easier concealment
- Choose Type 316 stainless steel for seaside applications and superior corrosion resistance

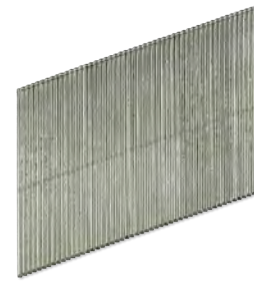

Compatible Pneumatic Tools

If you don't see your particular model in the table below, see pages 165-170 or call Simpson Strong-Tie and a sales professional will assist with fastener selection. (800) 999-5099

DeWalt®	DC618K
Duo-Fast®	FloorMaster 2505N
Hitachi®	NT65GB
Paslode®	900600, T250A-F16
Senco®	GT65RHA

Type 316 Stainless Steel

Penny Size	Length (in.)	500-count Model No.	2000-count Model No.
3d	1¼	T16N125PFB	T16N125PFN
4d	1½	T16N150PFB	T16N150PFN
6d	2	T16N200PFB	T16N200PFN
8d	2½	T16N250PFB	T16N250PFN

Type 304 Stainless Steel

Penny Size	Length (in.)	500-count Model No.	2000-count Model No.
3d	1¼	S16N125PFB	S16N125PFN
4d	1½	S16N150PFB	S16N150PFN
6d	2	S16N200PFB	S16N200PFN
8d	2½	S16N250PFB	S16N250PFN

Trim Nails

25° Angle, Adhesive Collation, FN-Style, 15-Gauge Finishing Nail

Features:

- T-style head minimizes the nail head size for easier concealment
- Choose Type 316 stainless steel for seaside applications and superior corrosion resistance

Compatible Pneumatic Tools

If you don't see your particular model in the table below, see pages 165-170 or call Simpson Strong-Tie and a sales professional will assist with fastener selection. (800) 999-5099

Bostitch® — N62FNK-2, GFN1546K

Makita® — AF632, AF631



Type 316 Stainless Steel

Penny Size	Length (in.)	500-count Model No.	2000-count Model No.
4d	1 ½	T15N150FNB	T15N150FNJ
6d	2	T15N200FNB	T15N200FNJ
8d	2 ½	T15N250FNB	T15N250FNJ

Type 304 Stainless Steel

Penny Size	Length (in.)	500-count Model No.	2000-count Model No.
4d	1 ½	S15N150FNB	S15N150FNJ
6d	2	S15N200FNB	S15N200FNJ
8d	2 ½	S15N250FNB	S15N250FNJ

Trim Nails

Straight, Adhesive Collation, T-Style Head, 16-Gauge Finishing Nail

Choose Type 316 stainless steel for seaside applications and superior corrosion resistance

Compatible Pneumatic Tools

If you don't see your particular model in the table below, see pages 165-170 or call Simpson Strong-Tie and a sales professional will assist with fastener selection. (800) 999-5099

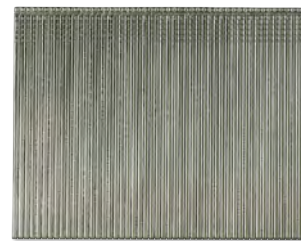

Bosch®	FNS250-16
Bostitch®	FN1664K, SB-1664FN, GFN1664K
DeWalt®	DC616K,D51257K
Duo-Fast®	FloorMaster 200-C, SureShot764 (up to 2")
Grip-Rite®	GRTFN250
Hitachi®	NT65A3,NT6GS, NT65M2
Max®	NF352-ST/16-50 (up to 2")
Paslode®	T250S-F16, 902000
Porter Cable®	FN250C
Ridgid®	R250SFA
Senco®	FinishPro32

Type 316 Stainless Steel

Length (in.)	500-count Model No.	2500-count Model No.
1¼	T16N125FNB	T16N125FNJ
1½	T16N150FNB	T16N150FNJ
2	T16N200FNB	T16N200FNJ
2½	T16N250FNB	T16N250FNJ

Type 304 Stainless Steel

Length (in.)	500-count Model No.	2500-count Model No.
1½	S16N150FNB	S16N150FNJ
2	S16N200FNB	S16N200FNJ
2½	S16N250FNB	S16N250FNJ

Trim Nails

Straight, Adhesive Collation, T-Style Head, 18-Gauge, Brads

Choose Type 316 stainless steel for seaside applications and superior corrosion resistance

Compatible Pneumatic Tools

If you don't see your particular model in the table below, see pages 165-170 or call Simpson Strong-Tie and a sales professional will assist with fastener selection. (800) 999-5099

Bosch®	BNS200-18
Bostitch®	BT1855K, SB-1850BN, SB-2IN1 (up to 1½"), GBT1850K
DeWalt®	DC51236K (up to 1¼"), D51238K
Duo-Fast®	SureShot 2232 (up to 1"), SureShot 4450 (up to 1½"), SureShot 4450 ST (up to 1½")
Grip-Rite®	GRTBN125 (up to 1¼"), GRTBN200
Hitachi®	NT32AE2 (up to 1¼"), NT50AE2, NT50GS
Makita®	AF505
Max®	NF235F/18 (up to 1¼"), NF201/18-35 (up to 1¼"), NF255-ST/18
Paslode®	T200-F18, 901000
Porter Cable®	BN138 (up to 1¼"), BN200B
Ridgid®	R213BNA
Senco®	SLP20XP (up to 1½"), FinishPro25XP



Type 316 Stainless Steel

Length (in.)	500-count Model No.	Carton Quantity	Model No.
¾	—	10000	T18N037FNJ
½	—	5000	T18N050FNJ
⅝	—	5000	T18N062FNJ
¾	T18N075FNB	5000	T18N075FNJ
1	T18N100FNB	5000	T18N100FNJ
1¼	T18N125FNB	5000	T18N125FNJ
1½	T18N150FNB	5000	T18N150FNJ
1¾	—	5000	T18N175FNJ
2	T18N200FNB	5000	T18N200FNJ

Type 304 Stainless Steel

Length (in.)	500-count Model No.	Carton Quantity	Model No.
¾	S18N075FNB	5000	S18N075FNJ
1	S18N100FNB	5000	—
1¼	S18N125FNB	5000	S18N125FNJ
1½	S18N150FNB	5000	S18N150FNJ
1¾	—	5000	S18N175FNJ
2	S18N200FNB	5000	S18N200FNJ

Trim Nails

Straight, Adhesive Collation, 23-Gauge, Micro Pins

Features:

- Headless micro pins
- Smooth shank

Compatible Pneumatic Tools

If you don't see your particular model in the table below, see pages 165-170 or call Simpson Strong-Tie and a sales professional will assist with fastener selection. (800) 999-5099

Bostitch®	HP118K
Duo-Fast®	SureShot 2236
Grip-Rite®	GRTPIN23
Hitachi®	NP35A
Max®	NF235A/23-35
Porter Cable®	PIN100 (up to 1"), PIN138
Ridgid®	R138HPA
Senco®	FinishPro11



Type 304 Stainless Steel

Gauge	Length (in.)	Carton Count	Model No.
23	½	1000	S23N050MPB
23	½	5000	S23N050MPN
23	¾	1000	S23N075MPB
23	¾	5000	S23N075MPN
23	1	1000	S23N100MPB
23	1	5000	S23N100MPN
23	1¼	1000	S23N119MPB
23	1¼	5000	S23N119MPN
23	1½	1000	S23N150MPB
23	1½	5000	S23N150MPN
23	1¾	1000	S23N175MPB
23	1¾	5000	S23N175MPN

Trim Nails

33° Tape Collation, DA-Style Angle, 15-Gauge Finishing Nail

Features:

- D-style head has greater bearing area to draw trim to the substrate
- Choose Type 316 stainless steel for seaside applications and superior corrosion resistance

Compatible Pneumatic Tools

If you don't see your particular model in the table below, see pages 165-170 or call Simpson Strong-Tie and a sales professional will assist with fastener selection. (800) 999-5099

Bosch®	FNA250-15
DeWalt®	DC628K, D51276K
Grip-Rite®	GRTAN250
Hitachi®	NT65GA, NT65MA4
Makita®	AF633
Max®	NF550/15-65
Porter Cable®	DA250C
Ridgid®	R250AFA, R250AF18
Senco®	Fusion F15, GT65DA, FinishPro42XP

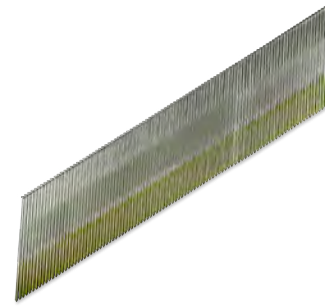

Type 316 Stainless Steel

Penny Size	Length (in.)	500-count Model No.	4000-count Model No.
3d	1 ¼	—	T15N125SFN
4d	1 ½	T15N150SFB	T15N150SFN
6d	2	T15N200SFB	T15N200SFN
8d	2 ½	T15N250SFB	T15N250SFN

Type 304 Stainless Steel

Penny Size	Length (in.)	500-count Model No.	4000-count Model No.
4d	1 ½	S15N150SFB	S15N150SFN
6d	2	S15N200SFB	S15N200SFN
8d	2 ½	S15N250SFB	S15N250SFN

Specialty

L Series Flooring Cleats

Ideal for tongue-and-groove decking and flooring

Compatible Pneumatic Tools

If you don't see your particular model in the table below, see pages 165-170 or call Simpson Strong-Tie and a sales professional will assist with fastener selection. (800) 999-5099

Bostitch®	MFN200, MFN201, MIIIFN
Grip-Rite®	GR200LCN
Hitachi®	NT50AF
Porter Cable®	FCN200
PowerNail®	45, 45R, 445SN, 101SN, 101R, 445, 445 FLEX Power Roller
Primatech®	P210L, P240L, P250L, H300L, H330L
Senco®	SHF50, SHF15

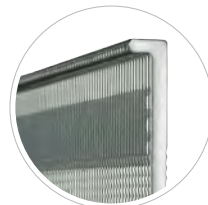
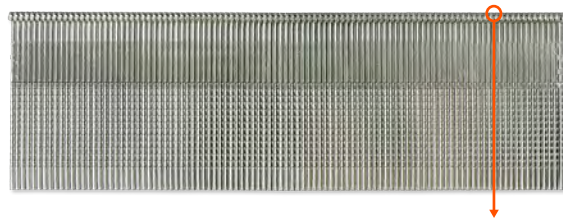

Type 304 Stainless Steel

Gauge	Length (in.)	Carton Quantity	Model No.
16	1 ½	1000	S16B150LCT
16	2	1000	S16B200LCT

T Series Flooring Cleats

Ideal for tongue-and-groove decking and flooring

Compatible Pneumatic Tools

If you don't see your particular model in the table below, see pages 165-170 or call Simpson Strong-Tie and a sales professional will assist with fastener selection. (800) 999-5099

Hitachi®	NT50AF, NT50AGF, NT50YF
Primatech®	P210T, P240T, P250T, H300T, H330T

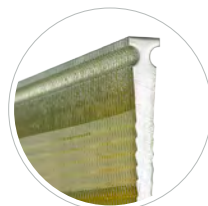
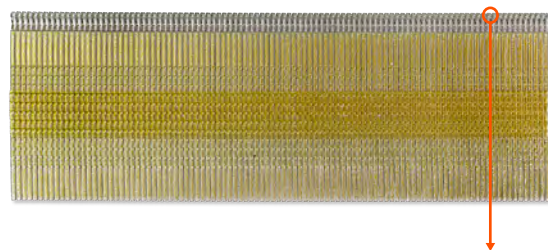

Type 304 Stainless Steel

Gauge	Length (in.)	Carton Quantity	Model No.
16	2	1000	S16B200TNL

Collated Nails and Staples

Collated Staples

½" Crown, 15½-Gauge Staples

(Similar to Bostitch® "BCS" Series)

Ideal for tongue-and-groove decking

Compatible Pneumatic Tools

If you don't see your particular model in the table below, see pages 165-170 or call Simpson Strong-Tie and a sales professional will assist with fastener selection. (800) 999-5099

Bostitch®	MIIIFS
Grip-Rite®	GR200FS
Hitachi®	N5009AF
PowerNail®	445FS, 445FS w/Power Roller
Primatech®	P220, P250S, P260

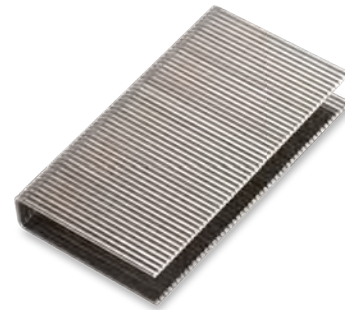

Type 304 Stainless Steel

Gauge	Length (in.)	Carton Quantity	Model No.
15½	2	5000	S15N200BFS

1" Crown, 16-Gauge Staples

(Similar to Senco® "P" Series)

Compatible Pneumatic Tools

If you don't see your particular model in the table below, see pages 165-170 or call Simpson Strong-Tie and a sales professional will assist with fastener selection. (800) 999-5099

Duo-Fast®	SW1748
Grip-Rite®	GRT1200-2
Hitachi®	N5024A2
Makita®	AT2550A
Senco®	MWXD, WC150XP, WC200XP



Type 316 Stainless Steel

Gauge	Length (in.)	Carton Quantity	Model No.
16	¾	5000	T16N075P51
16	1	5000	T16N100P53

Type 304 Stainless Steel

Gauge	Length (in.)	Carton Quantity	Model No.
16	¾	5000	S16N075P51
16	1¼	5000	S16N125P55

Collated Staples

1/2" Crown, 16-Gauge Staples

(Similar to Paslode® "GS" Series)

Compatible Pneumatic Tools

If you don't see your particular model in the table below, see pages 165-170 or call Simpson Strong-Tie and a sales professional will assist with fastener selection. (800) 999-5099

DeWalt® D51431

Hitachi® N5010A

Paslode® S200-S16, 900078NT



Type 304 Stainless Steel

Gauge	Length (in.)	1000 Count Model No.	Carton Quantity	Carton Model No.
16	1 1/4	S16N125GS-R1000	10,000	S16N125GS
16	1 1/2	S16N150GS-R1000	10,000	S16N150GS
16	1 3/4	S16N175GS-R1000	10,000	S16N175GS
16	2	—	10,000	S16N200GS

Collated Staples

1/4" Crown, 18-Gauge Staples

(Similar to Senco® "L" Series)

Compatible Pneumatic Tools

If you don't see your particular model in the table below, see pages 165-170 or call Simpson Strong-Tie and a sales professional will assist with fastener selection. (800) 999-5099

Bosch®	STN150-18
DeWalt®	D51420K (up to 1"), D51422K
Duo-Fast®	SureShot 1848F, SureShot 1832 (up to 1"), SureShot 1848, SureShot 1848SL, SureShot 1832ST (up to 1")
Grip-Rite®	GRTSN100 (up to 1"), GRSTN150A
Hitachi®	N3804AB3
Makita®	AT638
Max®	TA238A/18-6, TA238/18-6
Porter Cable®	NS100B (up to 1"), NS150B
Ridgid®	R150FSA
Senco®	SLS18MG



Type 316 Stainless Steel

Gauge	Length (in.)	Carton Quantity	Model No.
18	5/8	5000	T18N062L10
18	3/4	5000	T18N075L11
18	1	5000	T18N100L13
18	1 1/8	5000	T18N112L14
18	1 1/4	5000	T18N125L15
18	1 1/2	5000	T18N150L17

Type 304 Stainless Steel

Gauge	Length (in.)	1000 Count Model No.	Carton Quantity	Carton Model No.
18	5/8	—	5000	S18N062L10
18	1	S18N100L13-R1000	5000	S18N100L13
18	1 1/8	—	5000	S18N112L14
18	1 1/4	S18N125L15-R1000	5000	S18N125L15
18	1 1/2	S18N150L17-R1000	5000	S18N150L17

Collated Staples

7/16" Crown, 16-Gauge Staples

(Similar to Senco® "N" Series)

Compatible Pneumatic Tools

If you don't see your particular model in the table below, see pages 165-170 or call Simpson Strong-Tie and a sales professional will assist with fastener selection. (800) 999-5099

Bostitch®	438S5 (up to 1½"), 650S5
DeWalt®	D51430
Duo-Fast®	SM7648 (up to 1½"), SM7664, MS-7664E
Grip-Rite®	GRSTSM200
Hitachi®	N5008AC2
Makita®	AT1150A
Max®	TA551A/16-11, TA551/76, TA551/16-11
Porter Cable®	MS200
Senco®	SNS41, SNS44XP, SDS45XP, SNS50XP

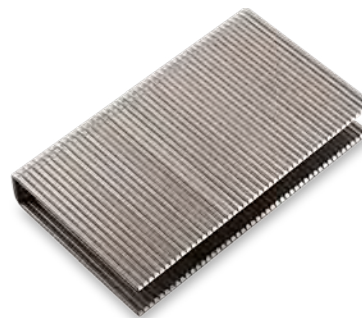

Type 316 Stainless Steel

Length (in.)	Carton Quantity	Carton Model No.
¾	5000	T16N075N11
1	5000	T16N100N13
1¼	5000	T16N125N15
1½	5000	T16N150N17
1¾	5000	T16N175N19
2	5000	T16N200N21

Type 304 Stainless Steel

Length (in.)	1000-count Model No.	Carton Quantity	Carton Model No.
1	—	5000	S16N100N13
1¼	S16N125N15-R1000	5000	S16N125N15
1½	S16N150N17-R1000	5000	S16N150N17
1¾	—	5000	S16N175N19
2	S16N200N21-R1000	5000	S16N200N21

Collated Staples

3/8" Crown, 22-Gauge Staples

(Similar to Senco® "C" Series)

Great for marine upholstery

Compatible Pneumatic Tools

If you don't see your particular model in the table below, see pages 165-170 or call Simpson Strong-Tie and a sales professional will assist with fastener selection. (800) 999-5099

BeA® 71/16-421, 71/16-436LN, 71/14-451

Porter Cable® US58

Senco® SFT10XP-C, SFW10XP-C, SFW09-C



Type 304 Stainless Steel

Gauge	Length (in.)	Carton Quantity	Model No.
22	1/4	10,000	S22N025C04
22	3/8	10,000	S22N037C06
22	1/2	10,000	S22N050C08

Collated Nail: Tool Compatibility Matrix – By Type

20-22° Plastic Strip

APACH AN-10021E	FASCO F6 RHN 20-90	MAKITA AN8300	PRIMEAIR PRH350
APACH L2190	GREX SF9021H	MAKITA AN922	RIDGID R350RHA
BESCO RHF 10021	GRIP-RITE GRTFR83	MAKITA AN923	SENCO FRAMEPRO 502
BESCO RHF 9021	GRIP-RITE GRTRH350	MAX GS683RH	SENCO FRAMEPRO 600 FRH
BESCO RHF 9021P	GRIZZLY G6050	MAX GS683RH-EX	SENCO FRAMEPRO 602
BOSCH SN350-20F	GRIZZLY H7665	MAX SN80	SENCO FRAMPRO 650 FRH
BOSTITCH F21PL	GRIZZLY H7943	MAX SN883RH	SENCO FRAMEPRO 652
BOSTITCH N79RH	HITACHI NR83A	MAX SN883RH2	SENCO FRAMPRO 700XL FRH
BOSTITCH N88RH	HITACHI NR83A2	MAX SN890RH	SENCO FRAMEPRO 702XP
BOSTITCH N88RH-2MCN	HITACHI NR83A2S	MAX SN90	SENCO FRAMEPRO 752XP
BOSTITCH N90RHN	HITACHI NR83AG	MILWAUKEE 7100-20	SENCO GT90FRH
BOSTITCH N95RHN	HITACHI NR83AS	NORTHERN TOOL 1000992	SENCO SN60
CAMPBELL HAUSFELD NS209000AV	HITACHI NR90AC	PALMGREN 91232	SENCO SN65
CRAFTSMAN 18178	HITACHI NR90AC2	PASLODE F350 SRH	SENCO SN65C
DEWALT D51844	HITACHI NR90AC3	PASLODE 5325 SRH	SENCO SN902XP
DEWALT D51845	HITACHI NR90AA2	PASLODE 5350 SRH-20	SENCO SN952XP
DEWALT D51850	HITACHI NR90AE	PORTER CABLE FR350	SPOTNAIL NPR90
DUO-FAST CN-350B	HITACHI NR90AEPR	PORTER CABLE FR350A	SPOTNAIL YPR90
DUO-FAST NSP-350F1	HITACHI NR90ALK	PORTER CABLE FR350MAG	STAN-TECH S011
DUO-FAST NSP-350F2	HITACHI NR90GR	POWERS W3-21FRH	SUPCO SFN88
FASCO F5C RHN 20-90	HITACHI NR90GR2	PREBENA 8F-RK100-S90	WEN 61792
FASCO F5C RHN 20-90A SS	ISM CHN921	PREBENA PKT-7-RK90	

31-34° Paper Tape and Plastic Strip

APACH AN-10034E	GREX SF9034H	MAX SN883CH/34	SENCO FRAMEPRO 600
APACH L3490	GRIP-RITE GRTFC83	MAX SN890CH/34	SENCO FRAMEPRO 601
ATRO CHS933	GRIP-RITE GRTCH350	NORTHERN TOOL 1000992	SENCO FRAMEPRO 650
BEA D100-934C	GRIZZLY H5571	PASLODE 5300 PWS	SENCO FRAMEPRO 651
BESCO CHF 9034	GRIZZLY H6146	PASLODE 5325	SENCO FRAMEPRO 701XP
BESCO CHF 9034P	GRIZZLY H7944	PASLODE 5350	SENCO FRAMEPRO 750XL
BOSCH SN350-34C	HITACHI NR83AA	PASLODE 900420	SENCO FRAMEPRO 751XP
BOSTITCH F33PT	HITACHI NR83AA2	PASLODE CF325	SENCO GT90CH
BOSTITCH N90PT-1	HITACHI NR83AA3	PASLODE F350S	SENCO SN4
CRAFTSMAN 18179	HITACHI NR90AA	PASLODE IM325	SENCO SN70
CRAFTSMAN 18189	HITACHI NR90AD	PASLODE IM325CT	SENCO SN70XP
DEWALT D51822	HITACHI NR90ADPR	PASLODE IM350	SENCO SN901XP
DEWALT D51823	HITACHI NR90GC	PASLODE IMCT	SENCO SN951XP
DEWALT D51825	HITACHI NR90GC2	PASLODE PF350S	SPOTNAIL NTD90
DUO-FAST CN-325B	ISM CHN933	PORTER CABLE FC350	SPOTNAIL YTD90
DUO-FAST NSPM-325F	MAKITA AN942	PORTER CABLE FC350A	STAN-TECH SDN11-PT-1
FASCO F5C HHN 31-90A SS	MAKITA AN943	POWERS W3-34CDH	SUPCO SDF88
FASCO F6 HHN 31-90	MAX GS683CH	PRIMEAIR PCH350	
GREX PPN65	MAX GS683CH-EX	RIDGID R350CHA	

31-34° Paper Strip, Structural Connector Nail

BOSTITCH F33PT	GRIP-RITE GRSB150-1½	PASLODE PF150S-PP	SENCO HN150
BOSTITCH MCN150	GRIP-RITE GRSB250-2½	PASLODE F250S-PP	SENCO HN250
BOSTITCH MCN250	HITACHI NR65AK	PNEU TOOLS RN-150	
GRIP-RITE GR150	HITACHI NR65AKS	PNEU TOOLS RN-250	
GRIP-RITE GR250	PASLODE 5250/65S-PP	PNEU TOOLS RNS-150	

Collated Nail: Tool Compatibility Matrix – By Type (cont.)

15° Wire Coil Decking/Framing

APACH CN-565	BOSTITCH N89C	HITACHI NV83A2	PORTER CABLE COIL250
APACH CN-57E	CRAFTSMAN 18214	MAKITA AN611	PORTER CABLE COIL350
APACH CN-70E	DEWALT 51855	MAKITA AN621	PREBENA 5F-CNW65-S
APACH CN-83E	DUO-FAST CNW-75	MAKITA AN901	PREBENA 7F-CNW90
APACH CN-90L	DUO-FAST DCN-325/85L	MAX CN100	SENCO PALLETPRO 70
ATRO ROLL 85	DUO-FAST P350C/CNW90	MAX CN565D	SENCO PALLETPRO 83
BESCO CN2755	DUO-FAST P275C	MAX CN565	SENCO PALLETPRO 90
BESCO CN2765	FASCO FSC-CN15W75	MAX CN565S	SENCO PALLETPRO 100
BESCO CN2970	FASCO R5C CN15W-90CT	MAX CN665	SENCO PALLETPRO 130
BESCO CN3375	GREX CN60	MAX CN70	SENCO SCN300
BESCO CN3890	GRIP-RITE GRTC90	MAX CN80	SENCO SCN49
BOSTITCH N100C	GRIP-RITE GRTCS250	MAX CN80F	SENCO SCN56
BOSTITCH N100CPP	GREX CN70-GR	MAX CN890II	SENCO SCN60XP
BOSTITCH N130C	GREX CN90	MAX CN890S	SENCO SCN65
BOSTITCH N70C	GRIZZLY H7949	MAX HN75	SENCO SCN65XP
BOSTITCH N70CB	GRIZZLY H7950	MAX HN90	SPOTNAIL MCW64 (up to 2½")
BOSTITCH N75C	GRIZZLY H8231	PASLODE 4275 / CN70	SPOTNAIL YCN83 (up to 3¼")
BOSTITCH N80C	HITACHI NV65AC	PASLODE 5325 / CN80	STAN-TECH SDCN12B-1
BOSTITCH N80CB	HITACHI NV75AG	PASLODE F275C / P275C	SUPCO SCN57
BOSTITCH N86C	HITACHI NV83A	PASLODE F325C / P350C	SUPCO SCN83

15° Wire Coil Siding

APACH CN-565	BOSTITCH N75C	MAX CN55	SENCO PALLETPRO 57F
APACH CN-57E	CRAFTSMAN 18214	MAX CN550S	SENCO SCN48
APACH CN-70E	DUO-FAST P275C	MAX CN565	SENCO SCN49
APACH CN-83E	FASCO F45C	MAX CN565D	SENCO SCN55S
BESCO CN2755	GREX CN60	MAX CN565S	SENCO SCN56
BESCO CN2765	GRIP-RITE GRTCS250	MAX CN665	SENCO SCN60XP
BOSTITCH N55C	GRIZZLY H7950	MAX CN70	SENCO SCN65XP
BOSTITCH N57C	GRIZZLY H8231	MAX HN65	SPOTNAIL MCW64
BOSTITCH N63CP	HITACHI NV65AC	PASLODE 3225/CN55	SPOTNAIL UCNM65
BOSTITCH N64C	HITACHI NV65AH	PORTER CABLE COIL200	SUPCO SCN57
BOSTITCH N65CP	HITACHI NV75AG	PORTER CABLE COIL250	
BOSTITCH N66C	MAKITA AN611	PRIMEAIR PCP250	

15° Wire Coil Roofing

APACH RN-45E	CRAFTSMAN 18324	JAMERCO JTCJ-45R	PREBENA 4X-CNZ45R
ARCHER CN45R	CRAFTSMAN 18444	MAKITA AN451	PRIMEAIR PCR175
ATRO CN134	DEWALT D51321	MAKITA AN453	PRIMEAIR PCR200
BEA 554DC	DUO-FAST DRN-45	MAX CN12R	RAMSOND CRN-45
BEA 555DC	DUO-FAST RN-175A	MAX CN445R	RIDGID R175RND
BESCO RF3132	GREX CR45	MAX CN450R	SENCO ROOFPRO 450
BESCO RF3145	GREX CR50	MILWAUKEE 7120-21	SENCO ROOFPRO 455XP
BESCO RF3145P	GREX RN45	NORTHERN TOOL 1000994	SENCO SCN200R
BOSCH RN175	GRIP-RITE GRTCR175	PALMGREN 91211	SENCO SCN40R
BOSTITCH N12	GRIZZLY H7951	PASLODE 3175/44RCU	SNAP-ON 870012
BOSTITCH N12B	GRIZZLY H8230	PASLODE 3175RCU	SPOTNAIL VRN45
BOSTITCH RN45	HILTI RFC-1348	PASLODE F-275C/P275C	STAN-TECH SDCN10-1
BOSTITCH RN45B	HITACHI NV45AB	PASLODE R175-C	SUPCO SR168
BOSTITCH RN46	HITACHI NV45AB2	PASLODE CR175C	SUREBONDER 9780
CAMPBELL HAUSFELD NC1545	HITACHI NV45AB2S	PORTER CABLE RN175	WEN 61782
CRAFTSMAN 154500	HITACHI NV45AC	PORTER CABLE RN175A	
CRAFTSMAN 18180	HITACHI NV45AE	PORTER CABLE 134R	

Not all tool models shown are compatible with all diameters and lengths in the fastener series shown.

Collated Nail: Tool Compatibility Matrix – By Type (cont.)

28° Wire Weld			
APACH AN-10028E	BOSTITCH N79WW	CRAFTSMAN 18430	HITACHI NR90AF
APACH L2890	BOSTITCH N80S	FASCO F5C HHN 28-90	ISM CHN928
BESCO CHF 9028	BOSTITCH N80SB	FASCO F6 HHN 28-90	MAX SN883CH/28
BOSTITCH F28WW	BOSTITCH N86S	GREX SF9028H	MAX SN890CH/28
BOSTITCH GF28WW	BOSTITCH N88WWB	GRIP-RITE GRPWCH350	NORTHERN TOOL 1000992
BOSTITCH N16	BOSTITCH N100S	GRIP-RITE GRTFW83	PORTER CABLE FM350A
BOSTITCH N70S	CAMPBELL HAUSFELD NS2890	GRIZZLY H6145	PRIMEAIR PWCH350
BOSTITCH N70SB	CRAFTSMAN 18320	GRIZZLY H8234	STAN-TECH 1526B
33° Tape “DA” Style Finish Nail			
ACCUSET A250FN	DEWALT D51276K	ISM 15DA250	SENCO FINISHPRO 41XP
AIRCO DA64	DEWALT DC628K	JAMERCO JTAFN1464	SENCO FINISHPRO 42XP
AIRY 0565T	DUO-FAST DAFN-6432	MAKITA AF631	SENCO Fusion F15
ARCHER BDA-1564	DUO-FAST DAFN-6480	MAKITA AF632	SENCO GT65DA
APACH DA-64E	FASCO F3C-BA-50	MAKITA AF633	SENCO SFN1
BESCO AFN1564P	FASCO F4-BA-65	MAX NF550/15-65	SENCO SFN1+
BESCO AFN1564S	FASCO F4-BA-65CT	MILWAUKEE 7140-21	SENCO SFN2
BOSCH FNA250-15	FASCO R3C-BA-50	PALMGREN 91251	SENCO SFN2B
CADEX DA1564	FASCO R4-BA-50	PORTER CABLE CDA250	SENCO SFN30
CAMPBELL HAUSFELD NB35666	FASCO R4-BA-65	PORTER CABLE DAFN-6480	SENCO SFN40
CAMPBELL HAUSFELD NB356500	GREX AF64	PORTER CABLE DA250	SENCO SFN65DA
CAMPBELL HAUSFELD NB356500AV	GRIP-RITE GRTAN250	PORTER CABLE DA250A	SENCO SN1
CAMPBELL HAUSFELD NB356599AV	GRIZZLY G6049	PORTER CABLE DA250B	SPOTNAIL KBA1564
CRAFTEX CT124	GRIZZLY H6144	PORTER CABLE DA250C	SPOTNAIL XBA1564
CRAFTSMAN 18177	HITACHI NT65AA	PREBENA 5X-DA63-S90	STANLEY SDA250K
CRAFTSMAN 18329	HITACHI NT65GA	PRIMEAIR PAN250	SUPCO SDA50
CRAFTSMAN 18432	HITACHI NT65MA	RIDGID R250AF18	SUPCO SDA64
CRAFTSMAN 18448	HITACHI NT65MA2	RIDGID R250AFA	WEN 61760
DEWALT D51275	HITACHI NT65MA3	SENCO AIRFREE 41	
DEWALT D51275K	HITACHI NT65MA4	SENCO FINISHPRO 35	
16-Gauge, 20° Adhesive, T-STYLE HEAD			
DEWALT DC614KA	DEWALT DC618K	GRIZZLY H7995	PASLODE IM250A
DEWALT DC614KN	DUO-FAST FLOORMASTER 250BN	HITACHI NT65GB	PASLODE T250A-F16
DEWALT DC615KA	GRIZZLY H7945	PASLODE 900600	SENCO GT65RHA
15-Gauge, 25° Adhesive, FN Style			
APACH LT-1564AF	BOSTITCH N62FNK-2	MAKITA AF632	STAN-TECH SDN-15BR
ATRO MONZA 64 DB 18	BOSTITCH GFN 1564K	MAX NF510/15-50	
BOSTITCH N60FN	MAKITA AF631	SPOTNAIL XBFN64	

Collated Nail: Tool Compatibility Matrix – By Type (cont.)

16-Gauge Straight, Adhesive, T-Style Head Finishing Nail

AIRY ATF-0350	CRAFTSMAN 18176	HITACHI NT65A	PASLODE T250-F16
AIRY ATM-0365	CRAFTSMAN 18314	HITACHI NT65A2	PASLODE T250S-F16
APACH LT-1650AC	DEWALT D51256K	HITACHI NT65A3	PORTA-NAILER 462
ATRO MINOR 600	DEWALT D51257K	HITACHI NT65GS	PORTER CABLE FN250A
BESCO NT1650-BES	DEWALT DC612KA	HITACHI NT65M	PORTER CABLE FN250B
BESCO NT1664	DEWALT DC613KA	HITACHI NT65M2	PORTER CABLE FN250C
BESCO NT1664P	DEWALT DC616K	ISM BN 16-200	PREBENA 3C-N65-S90
BOSCH FNS250-16	DUO-FAST FLOORMASTER 200-C	ISM BN 16-250	PRIMEAIR PFN250
BOSTITCH FN16250K-2	DUO-FAST LFN-764A	JAMERCO JTFN-1664	RIDGID R250SFA
BOSTITCH FN1664K	DUO-FAST LFN448	MAX NF352-ST/16-50	SENCO FINISHPRO 32
BOSTITCH SB-1664FN	DUO-FAST SURE SHOT 764	MAXUS MXN064	SPOTNAIL FB1632
BOSTITCH T36-50	FASCO R3T FN-70 CT	MAXUS MXN06499	SPOTNAIL WB1650
BOSTITCH GFN1664K	GREX 1664	MILWAUKEE 7145-21	SUPCO S1650
BOSTITCH T40B	GREX NT1650	PALMGREN 91261	SUPCO S1650X
CADEX FN1664	GRIP-RITE GRTFN250	PASLODE 3200-F16	SUPCO S1664
CAMPBELL HAUSFELD NB00050	GRIZZLY G7578	PASLODE 3250-F16	SUPCO ST65
CAMPBELL HAUSFELD NB00065	GRIZZLY H2910	PASLODE 902000	WEN 61750
CAMPBELL HAUSFELD NB005099AV	GRIZZLY H6143	PASLODE IM250II	
CRAFTSMAN 18175	HAUBOLD SKN64A	PASLODE MU-212F	

18-Gauge Straight, Adhesive, T-Style Head Brads

ACCUSET A125BN	CAMPBELL HAUSFELD NB004099	GRIZZLY H7664	PORTER CABLE BN200B
ACCUSET A200BN	CRAFTSMAN 18172	GRIZZLY H7679	PORTER CABLE BN200V12
AIRY 0241NK	CRAFTSMAN 18173	HITACHI NT32AE	PREBENA 2P-J50SDS-S90
APACH LNF-32AC	CRAFTSMAN 18174	HITACHI NT32AE2	PREBENA 2X-J50SD-S90
APACH LNF-42AC	CRAFTSMAN 18323	HITACHI NT50AD	PRIMEAIR PFB125
APACH LNF-50AC	DEWALT D51236K	HITACHI NT50AE	PRIMEAIR PFB200
APACH LU-32FAC	DEWALT D51238K	HITACHI NT50AE2	RIDGID R213BNA
APACH LU-50FAC	DEWALT DC608K	HITACHI NT50GS	SENCO AIRFREE 25
ARROW 091-ETF50PBN	DUO-FAST DBN-4440	ISM BN 18-125	SENCO FINISHPRO 15
ARROW ET200	DUO-FAST DBN-4450	JAMERCO JTBN 1832	SENCO FINISHPRO 18
BESCO BN1842	DUO-FAST SURESHOT 2232	JAMERCO JTBN 1850	SENCO FINISHPRO 25XP
BESCO BN1850	DUO-FAST SURESHOT 4450	MAKITA AF502	SENCO FINISHPRO 2N1
BESCO BN1855P	DUO-FAST SURESHOT 4450 ST	MAKITA AF503	SENCO SLP20XP
BLACK & DECKER FSNS125	EZ-FASTEN F18/32VM	MAKITA AF505	SENCO LS5
BLACK AND DECKER BDBN1202	FASCO F20P GN31/40	MAX NF201/18-35	SENCO SLP20
BLACK AND DECKER FS1802BN	FASCO F21T GN-40A CT	MAX NF211/18-25	SPOTNAIL CB1820
BLACK AND DECKER FSBN125	FASCO R3C GN50SS	MAX NF211/18-50	SPOTNAIL CB1832
BLACK AND DECKER FSNS125	GREX 1832	MAX NF221/18-55	SPOTNAIL CB1850
BOSCH BNS200-18	GREX 1850	MAX NF235F/18	SPOTNAIL TB1840
BOSTITCH BT125K	GREX BS5032	MAX NF255-ST/18	SPOTNAIL WB1850
BOSTITCH BT125K-2	GRIP-RITE GRTBN125	MAXUS MXN10299	STAN-TECH SDN 18BR
BOSTITCH BT1855K	GRIP-RITE GRTBN200	MAXUS MXN10499	STANLEY TRE50
BOSTITCH BT200K-2	GRIZZLY G6045	MILWAUKEE 7150-21	SUPCO F30/32
BOSTITCH BT35B	GRIZZLY G6046	PALMGREN 91181	SUPCO F32
BOSTITCH BT50B	GRIZZLY G6047	PASLODE 2138-F18II	SUPCO F32X
BOSTITCH GBT1850K	GRIZZLY G8126	PASLODE 901000	SUPCO S1840E
BOSTITCH SB-1842BN	GRIZZLY G9248	PASLODE IM200-F18	SUPCO S1850E
BOSTITCH SB-1850BN	GRIZZLY H2911	PASLODE T125-F18	WEN 61715
BOSTITCH SB-2IN1	GRIZZLY H2912	PASLODE T200-F18	WEN 61720
CADEX BN1850	GRIZZLY H2913	PORTER CABLE BN125A	WESTWARD 4VZ69
CAMPBELL HAUSFELD NB0030	GRIZZLY H5527	PORTER CABLE BN138	WESTWARD 4VZ70
CAMPBELL HAUSFELD NB003099AV	GRIZZLY H6332	PORTER CABLE BN200A	

Not all tool models shown are compatible with all diameters and lengths in the fastener series shown.

Collated Nail/Staple: Tool Compatibility Matrix – By Type (cont.)

23-Gauge Straight, Adhesive Collation , Micro Pins

BOSTITCH HP118K	FASCO F1B A-64 12/18	GRIP-RITE GRTPIN23	SENCO FINISHPRO 10
CADEX CPB23.30	FASCO F23A64-35PB	HITACHI NP35A	SENCO FINISHPRO 11
CADEX CPB23.35	FASCO F23C A64-50PB	MAX NF235A/23-35	SENCO FINISHPRO 23LXP
CADEX CPB23.50	GREX P630	PORTER CABLE PIN 100	SENCO FINISHPRO 23LXP
DUO-FAST SURESHOT 2236	GREX P635	PORTER CABLE PIN 138	SPOTNAILS SP2340
		RIDGID R138HPA	

L Series Flooring Cleats

AKUZUKI X-799	GRIP-RITE GR200LCN	POWERNAIL 45R	PRIMATECH Q500
AKUZUKI X-799PRO	GRIZZLY H7826	POWERNAIL 101R	RAMSOND RMM4
BESCO MFN 50	HIGHPRO LFN50	POWERNAIL 345	SENCO SHF10
BOSTITCH HFN1	HITACHI NT50AF	POWERNAIL 445	SENCO SHF15
BOSTITCH MFN200	NUMAX SFL618BR	POWERNAIL 445 FLEX POWER ROLLER	SENCO SHF50
BOSTITCH MFN201	PORTA-NAILS 402P	POWERNAIL 445SN	SPOTNAIL FCL2650
BOSTITCH MIIFN	PORTA-NAILS 410	PRIMATECH H300L	SUPERIOR FCN150
CAMPBELL HAUSFELD CH50399	PORTA-NAILS 412	PRIMATECH H330L	SUPERIOR FSN200
DUO-FAST FLOORMASTER 200-C	PORTA-NAILS 470	PRIMATECH P210L	WEN 61950
EAGLE LFN-50	PORTER CABLE FCN200	PRIMATECH P240L	
FREEMAN PFL618BR	POWERNAIL 45	PRIMATECH P250L	

T-Series Flooring Cleats

HITACHI NT50AF	PORTA-NAILS 401	PRIMATECH P210T	PRIMATECH H300T
HITACHI NT50AGF	PORTA-NAILS 421	PRIMATECH P240T	PRIMATECH H330T
HITACHI NT50YF	PORTA-NAILS 501	PRIMATECH P250T	

Collated Staples

½" Crown, 15½-Gauge (Similar to Bostitch BCS Series)

APACH MFS-50	GREX MS1250	PORTA-NAILS 472	PRIMATECH P260
BESCO MFS 50	GRIP-RITE GR200FS	POWERNAIL 445FS	SPOTNAIL FS7550
BOSTITCH MIIFFS	GRIZZLY H5977	POWERNAIL 445FS w/Power Roller	SPOTNAIL MS7564
DUO-FAST FLOORMASTER 200-S	HIGHPRO FS50	PRIMATECH P220	SUPCO SFS
EAGLE FS-50	HITACHI N5009AF	PRIMATECH P250S	

7/16" Crown, 16-Gauge (Similar to Senco N Series)

APACH LU-851F	DUO-FAST SM7648	MAKITA AT1150A	SENCO SNS44XP
APACH LU-851L	FASCO F4P-G-50	MAX TA551/16-11	SENCO SNS45
APACH LU-864F	FASCO FC3 G-40 CT	MAX TA551/76	SENCO SNS45XP
BESCO MS 851S	GREX 1151	MAX TA551A-16-11	SENCO SNS50
BOSTITCH 438S5	GRIP-RITE GRTSM200	PORTER CABLE MS200	SENCO SNS50XP
BOSTITCH 650S5	GRIZZLY G6044	PRIMEAIR PSI200	SPOTNAIL MS6650I
CADEX TNS16851	HITACHI N5008AB	SENCO SDS45XP	SPOTNAIL XS6650
DEWALT D51430	HITACHI N5008AC	SENCO SKS N	STAN-TECH SD716-716
DUO-FAST MS-7664E	HITACHI N5008AC2	SENCO SNS40	SUPCO SN38
DUO-FAST SM-7664	ISM MC716200	SENCO SNS41	SUPCO SN50X

½" Crown, 16-Gauge (Similar to Paslode GS Series)

DEWALT D51431	PASLODE 3150-S16	PASLODE 900078NT	PASLODE PA-200
HITACHI N5010A	PASLODE 3200-S16P	PASLODE IM200-S16	PASLODE S200-S16

Not all tool models shown are compatible with all diameters and lengths in the fastener series shown.

Collated Staples: Tool Compatibility Matrix – By Type (cont.)

½" Crown, 16-Gauge (Similar to Bostitch BCS Series)

BESCO 951 FS	BOSTITCH 750S4	CRAFTSMAN 18410	SPOTNAIL MS76-8650I
BESCO MS 951S	BOSTITCH T36-1	FASCO HD	SPOTNAIL XS76-8650
BOSTITCH 438S4	BOSTITCH T38	GRIZZLY G6772	SUPCO SBP50
BOSTITCH 538S4	BOSTITCH T40S4	ISM VULCANO 16NC	
BOSTITCH 650S4	BOSTITCH T50S4	SPOTNAIL HL7616A	
BOSTITCH 650S4-1	BOSTITCH T55S4	SPOTNAIL HL7616AP	

1" Crown, 16-Gauge (Similar to Senco P Series)

BESCO WS 2538	FASCO R3C-SNW-38R	SENCO MW	SENCO WC150XP
BESCO WS 2638	GREX 2638	SENCO MWXP	SENCO WC200XP
CRAFTSMAN 18415	GRIP-RITE GRT1200-2	SENCO PW	SPOTNAIL XS3640
DUO-FAST KW1748	HITACHI N3824A	SENCO PW150	SPOTNAIL XS3650
DUO-FAST RS1748	HITACHI N5024A	SENCO PW150R	STAN-TECH SDS16-1
DUO-FAST SW1748	HITACHI N5024A2	SENCO PW2	SUPCO SSW2640
FASCO F30-SNW-50R	MAKITA AT2550A	SENCO PW200	
FASCO F3C SNW-38TL CT ROOF	PRIMEAIR PSW150	SENCO SPS	

¼" Crown, 18-Gauge (Similar to Senco L Series)

ACCUSET A100LS	CADEX SF9032B	FASCO F25A-90/40	PORTER CABLE NS100A
ACCUSET A150LS	CADEX SF9040L	FASCO F3C 90-40 CT 1	PORTER CABLE NS100B
AIRY ASF-0638P	CAMPBELL HAUSFELD SN258K	GREX 9040-GR	PORTER CABLE NS150A
AIRY ASM-0645	CENTRAL PNEUMATIC 45728-6VGA	GREX BS5032	PORTER CABLE NS150B
AIRY AST-0626S	CRAFTSMAN 18169	GRIP-RITE GRTSN100	PREBENA 2P-E40SDS-S90
APACH AFS-9040	CRAFTSMAN 18171	GRIP-RITE GRTSN150	PREBENA 2X-E40SD-S90
APACH LU-32FAC	CRAFTSMAN 18176	GRIP-RITE GRTSN150A	PRIMEAIR PSN125
APACH LU-50FAC	CRAFTSMAN 18435	GRIZZLY G8126	RIDGID R150 FSA
APACH LU-9025AC	DEWALT D51420K	GRIZZLY G9248	SENCO SKS L
APACH LU-9032AC	DEWALT D51422K	GRIZZLY H2912	SENCO SLS18MG
APACH LU-9040HAC	DUO-FAST 1848F	GRIZZLY H2913	SENCO SLS20
APACH LU-9040HK	DUO-FAST DNS-1840	GRIZZLY H7664	SENCO SLS20XP-L
APACH LU-9040K	DUO-FAST KB-1836	HIGHPRO AS4090	SENCO SLS25XP
APACH LU-9040LAC	DUO-FAST KN-1848A	HIGHPRO AS9040L	SENCO SLS25XP-L
ATRO MINOR 90/38	DUO-FAST SURESHOT 1820	HITACHI N3804AA	SPOTNAIL FS4825
BEA 90/25-552	DUO-FAST SURESHOT 1832	HITACHI N3804AB	SPOTNAIL HL3852
BEA 90/32-611	DUO-FAST SURESHOT 1832ST	HITACHI N3804AB2	SPOTNAIL TS4825
BEA 90/38-150	DUO-FAST SURESHOT 1848	HITACHI N3804AB3	SPOTNAIL WS4840
BEA 90/40-621	DUO-FAST SURESHOT 1848F	ISM 18NC150	STAN-TECH SDS18-14-26
BESCO 9025 FS	DUO-FAST SURESHOT 1848SL	MAKITA AT638	SUPCO DF40
BESCO 9038 FS	FASCO F20-40	MAX TA238/18-6	SUPCO SK9032
BESCO NS 9025	FASCO F20P 90-25	MAX TA238A/18-6	SUPCO SK9040
BESCO NS 9038LW	FASCO F20T 90-30 CT	MAXUS MXN103	WEN 61710
BESCO NS 9040HD	FASCO F20T 90-40 CT	MAXUS MXN10499	WESTWARD 4VZ68
BLACK AND DECKER FSNS125	FASCO F21P 90-25A	MILWAUKEE 7155-21	
BOSCH STN150-18	FASCO F21T 90-40A	PORTA-NAILER 461	

Not all tool models shown are compatible with all diameters and lengths in the fastener series shown.

Collated Screws for the Quik Drive® System

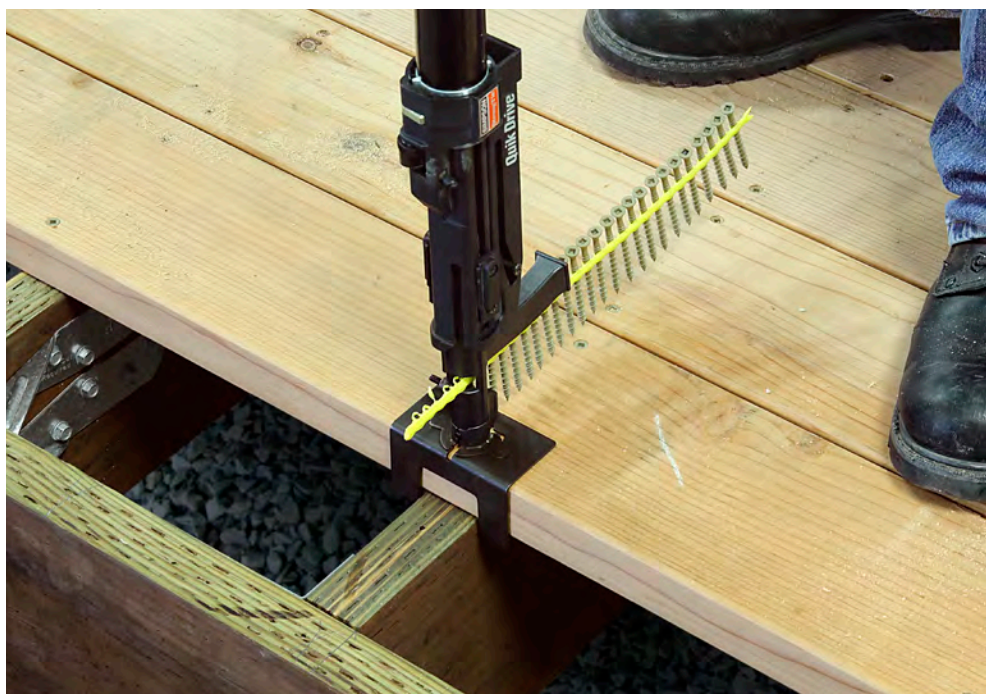



Application / Fastener / Tool Matrix

Collated Screws for the Quik Drive® System

Application / Screw	Page	Suitable Systems/Attachments					
		PRO200S	PRO250	PRO300S	PRORF	PRO300SRF	PROLDH
Deck/Dock							
DCLB212S	186		✓	✓			
DCLB3S	186			✓			
DCLG212S	186		✓	✓			
DCLG3S	186			✓			
DCLR212S	186		✓	✓			
DCLR3S	186			✓			
DCLT212S	186		✓	✓			
DCLT3S	186			✓			
DSVT158S	174	✓	✓	✓			
DSVT2S	174	✓	✓	✓			
DSVT212S	174		✓	✓			
DSVT3S	174			✓			
DTHQ2S	176	✓	✓	✓			
DTHQ212S	176		✓	✓			
DTHQ3S	176			✓			
SS3DSC212BS	177			✓			
SS3DSC212BS316	177			✓			
SS3DSC3BS	177			✓			
SS3DSC3BS316	177		✓	✓			
SSDCL212S	186		✓	✓			
SSDCL3S	186			✓			
SSDHPD212S	175			✓			
SSDTH2S	176	✓	✓	✓			
SSDTH212S	176		✓	✓			
SSDTH3S	176			✓			
SSDWP212S305	174			✓			
SSDWP3S305	174			✓			
SSDWP212S316	174			✓			
SSDWP3S316	174			✓			
WSCG134S	184	✓	✓	✓			
WSNTLG2S	174	✓	✓	✓			
WSNTLG212S	175		✓	✓			
WSNTLG3S	175			✓			
WSNTLQ212S	175		✓	✓			
WSNTLQ3S	175			✓			
Wood-to-Wood							
WSC114S-17	193	✓					
WSC112S	193	✓	✓	✓			
WSCLT134S	193	✓	✓	✓			
WSHL134S7	190	✓	✓	✓			
WSNTL134S	188	✓	✓	✓			
WSNTL2LS	188	✓	✓	✓			
WSNTL2LS-17	188	✓	✓	✓			
WSNTL212S	188		✓	✓			
WSNTL3S	188			✓			
Underlayment							
CB3BLG114S	177						✓
CB3BLGHL114S	178						✓
CB3BLG158S	177			✓			✓
CB3BLGHL158S	178						✓
MTH114S	191	✓					
MTHZ1S	191	✓					
Fiber-Cement Siding-to-Steel							
CBSDQ158S	199	✓	✓				
CBSDQ214S	199		✓	✓			
Tile Roofing							
SSWSC2BS	184				✓	✓	
SSWSC134BS	184	✓	✓	✓	✓	✓	
SSWSC212BS	184				✓	✓	
WSCD212S	185				✓	✓	
WSCD3S	185					✓	
WSCT212S	185				✓	✓	
Crating							
PHSS2S	193	✓	✓	✓			
PHSS212S	193		✓	✓			
Truss-Ply Fastening							
WSNTL212S	188		✓	✓			
WSNTL3S	188			✓			

C-F-14 © 2014 SIMPSON STRONG-TIE COMPANY INC. (This page has been updated since printing)



Application / Fastener / Tool Matrix

Application / Screw	Page	Suitable Systems/Attachments												
		PRO200	PRO200S	PRO250DW	PRO250	PRO300S	PROPP150	PROHX516	PROSD150	PROPH	PROHSD60	PROHSD75	BGP300	PROHX14
Drywall														
DWC1PS	190	✓												
DWC114PS	190	✓												
DWC158PS	190	✓												
DWC2PS	190	✓		✓										
DWC212PS	190			✓										
DWCZ114PS	190	✓												
DWCZ158PS	190	✓												
DWCZ2PS	190	✓		✓										
DWF1PS	200	✓												
DWF114PS	190	✓												
DWF158PS	200	✓												
DWFSD114PS	200	✓	✓*											
DWFSD158PS	200	✓	✓*											
DWFSD178PS	200	✓		✓										
DWFSD238PS	200			✓										
DWFSDG114PS	200	✓	✓*											
DWHL178PS	191	✓		✓										
Metal Roofing/Siding-to-Wood/Steel														
PC1BS1012	192						✓							
PC1BS1211	192						✓							
PCQ1BS1012	182						✓							
PCQ1BS1211	182						✓							
PCQ112BS1012	182						✓							
SSPC1BS1012	192						✓							
PCSD1S1016	198						✓							
PCSD1S1214	198						✓							
PCSDQ1S1016	198						✓							
PCSDQ1S1214	198						✓							
SSPCSD1S1016	198						✓							
PCULP1BS1012	192						✓							
PCULP112BS1012	192						✓							
PCULPQ1BS1012	183						✓							
PCULPQ112BS1012	183						✓							
SSPCULP1BS1012	192						✓							
HJ112WT10	180											✓		
HG112WS	180													✓
HG112WT10	180											✓		
Steel-to-Steel														
FPHSD34S1016	195							✓	✓					
FPHSD34S1214	195							✓	✓					
PHSD34S0818	195								✓					
X1S1016	197						✓	✓	✓					
XQ1S1016	197						✓	✓	✓					
X1S1214	197						✓	✓	✓					
XQ1S1214	197						✓	✓	✓					
XQ78S1224	197							✓	✓					
XQ114S1224	197								✓					
XQ112S1224	197								✓					
PPSD11516S0818	196		✓		✓									
PPSD134S1016	196		✓		✓		✓							
PPSD3S1016	196						✓							
PPSD3S1214	196											✓		
PPSD134S1214	196									✓				
Wood-to-Steel														
FHSD1S1018	201	✓	✓											
FHSD114S0818	201	✓	✓											
FHSD212S1214	201													
TB1445S	194									✓				
TB1460S	194									✓		✓		
TB1475S	194											✓		
TBG1445S	194									✓				
TBG1460S	194									✓		✓		
TBG1475S	194											✓		
WSF1LRVS	201		✓											
WSF134LRVS	201		✓		✓		✓							
Composite Decking-to-Steel														
DCSD238SBR01	187				✓		✓							
DCSD238SRD01	187				✓		✓							
DCSD238STN01	187				✓		✓							
DCSD238STN02	187				✓		✓							
DCSD238SGR01	187				✓		✓							
DCSD238SGR04	187				✓		✓							

* Drive with PRO200S only when fastening fiberglass-mat gypsum sheathing panels

Collated Exterior Wood Screws



SIMPSON
Strong-Tie

Deck-Drive™ DSV WOOD Screw

Preservative-Treated Decking and Exterior Wood-to-Wood Applications

The DSV screw is a powerful fastening solution for preservative-treated decking applications. With its under-head nibs and fast-start tip, the DSV is ideally suited to be driven and countersunk into today's wood deck boards. The shank is designed to withstand the swelling and shrinkage that is common with fast-growth lumber. Available in hand-drive and in collated strips for use in our Quik Drive® auto-feed screw driving system, DSV screws are also offered in a variety of sizes to fasten fascia and trim.

Features:

- Low-torque threads
- Ribbed head design countersinks easily and provides a clean, finished appearance
- High-low tip provides fast starts
- Optimized threads for dimensional lumber
- Quik Guard® coating provides corrosion resistance for exterior and certain preservative-treated wood applications
- Meets the performance requirements of AC257 exposure conditions 1 and 3
- Tan color blends in with most woods
- This screw is also available in bulk for hand-drive installation. See page 63 for details.

Quik Guard® Coating

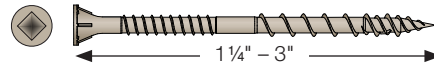

Size	Length (in.)	500 ct. Model No.	750 ct. Model No.	1000 ct. Model No.	1500 ct. Model No.	2000 ct. Model No.	PRO 300S	PRO 250	PRO 200S
# 8	1 1/4	—	HCKDSVT114S	—	—	DSVT114S		✓	✓
# 8	1 5/8	—	HCKDSVT158S	—	—	DSVT158S		✓	✓
#10	2	—	HCKDSVT2S	—	DSVT2S	—	✓	✓	✓
#10	2 1/2	HCKDSVT212S	—	DSVT212S	—	—	✓	✓	
#10	3	HCKDSVT3S	—	DSVT3S	—	—	✓		

Tan

These coated fasteners possess a level of corrosion resistance that makes them suitable for use in some exterior and corrosive environments and with some preservative-treated woods. For applications in higher-exposure applications, consider Type-300 series stainless-steel fasteners for superior corrosion resistance. See page 15 for additional important information before selecting a fastener for a specific application.

Deck-Drive™ DWP WOOD SS Screw

Decking, Docks and Boardwalks; Finishing, Millwork and Trim

The DWP screw is a powerful fastening solution for deck, dock, and general exterior applications where extra corrosion protection is needed. With its specially designed sharp-point and unique box-threads, the DWP is ideally suited for the majority of wood used in today's wood deck boards. Choose Type 316 stainless steel for seaside and coastal environments. Available in hand-drive and in collated strips for use in our Quik Drive® auto-feed screw driving system, DWP screws are also offered in a variety of sizes to fasten fascia and trim.

Features:

- Unique "box" thread design with raised-ridge technology, greatly reduces driving torque
- Specially-designed sharp point penetrates hard wood products with ease
- 6-lobe drive helps prevent driver-bit cam-out while driving easier and extending bit life (replacement bit BITTX25, see page 264 for more information).
- Choose Type 316 stainless steel for seaside applications and superior corrosion resistance
- This screw is also available in bulk for hand-drive installation. See page 64 for details.

Type 316 Stainless Steel

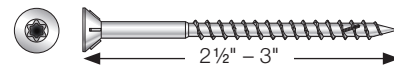

Size	Length (in.)	Material	1000 ct. Model No.	1500 ct. Model No.	PRO 300S
#10	2 1/2	316SS	—	SSDWP212S316	✓
#10	3	316SS	SSDWP3S316	—	✓

Type 305 Stainless Steel

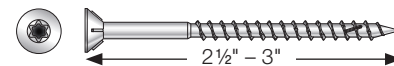

Size	Length (in.)	Material	1000 ct. Model No.	1500 ct. Model No.	PRO 300S
#10	2 1/2	305SS	—	SSDWP212S305	✓
#10	3	305SS	SSDWP3S305	—	✓



Collated Exterior Wood Screws

Deck-Drive™ DHPD HARDWOOD Screw

Hardwood Decking, Docks and Boardwalks

The DHPD hardwood decking screw is specially designed to penetrate the hardest wood products with ease. With its unique paddle-style drill point, it virtually eliminates splitting without predrilling. The wings on the shaft counterbore hard material, allowing the head to countersink easily for a clean finished look. Available in Type 305 stainless steel for addition corrosion protection.

Features:

- Penetrate the hardest wood products without predrilling
- Compact head ensures a low-profile installation and reduced visibility
- Wings on the shaft counter-bore hard material and allow the head to countersink for a clean look
- Driver bit included in each package
- #2 square drive (replacement bit model BIT2S, see page 264 for more information)
- This screw is also available in bulk for hand-drive installation. See page 66 for details.

Type 305 Stainless Steel

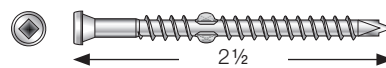

Length (in.)	Shank Size	Threads Per Inch	Color	Retail Pack		Contractor Pack		PRO 300S	PRO 250
				Fasteners Per Pack	Model No.	Fasteners Per Pack	Model No.		
2½	#10	10	Unpainted	500	HCKSSDHPD212S	1000	SSDHPD212S	✓	✓
2½	#10	10	Tan03 (Ipê)	—	—	1000	SSDHPD212SB	✓	✓



Strong-Drive® WSNTL WOOD Screw

Exterior Wood-to-Wood Applications

Common Applications:

Decking to wood

Features:

- Flat head with nibs for easy countersinking
- #3 square drive (driver bit in each box; replacement bit model BIT3SU)
- Twin threads
- Sharp point
- Curved collation

Quik Guard® Coating

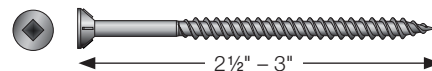

Length (in.)	Shank Size	#3 Drive Type	Retail Pack		Contractor Pack		PRO 250	PRO 300S
			Fasteners Per Pack	Model No.	Fasteners Per Pack	Model No.		
2½	#8	Undersized	—	—	1500	WSNTLQ212S	✓	✓
3	#8	Undersized	—	—	1000	WSNTLQ3S		✓

Mechanically Galvanized – Class 55

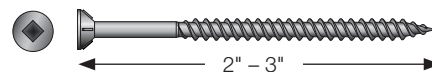

Length (in.)	Shank Size	#3 Drive Type	Retail Pack		Contractor Pack		PRO 200S	PRO 250	PRO 300S
			Fasteners Per Pack	Model No.	Fasteners Per Pack	Model No.			
2	#8	Undersized	1000	HCKWSNTLG2S	2000	WSNTLG2S	✓	✓	✓
2½	#8	Undersized	750	HCKWSNTG212S	1500	WSNTLG212S		✓	✓
3	#8	Undersized	500	HCKWSNTLG3S	1000	WSNTLG3S			✓

These coated fasteners possess a level of corrosion resistance that makes them suitable for use in some exterior and corrosive environments and with some preservative-treated woods. For applications in higher-exposure applications, consider Type-300 series stainless-steel fasteners for superior corrosion resistance. See page 15 for additional important information before selecting a fastener for a specific application.



Collated Exterior Wood Screws

Trim-Head Decking Screw – Sharp Point

Features:

- Trim head
- #2 square drive (driver bit in each box; replacement bit model BIT2S)
- Box threads
- Curved collation
- Painted heads available in colors to match Azek® decking as well as a variety of decking colors from other manufacturers

Type 305 Stainless Steel

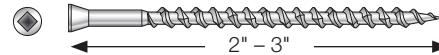

Length (in.)	Shank Size	Head Color	Contractor Pack		PRO 250	PRO 300S
			Fasteners Per Pack	Model No.		
2	#7	Unpainted	500	SSDTH2S	✓	✓
2½	#7	Unpainted	500	SSDTH212S	✓	✓
3	#7	Unpainted	500	SSDTH3S	✓	✓
2½	#7	BR02	1000	SSDTH212SBR02	✓	✓
2½	#7	TN02	1000	SSDTH212STN02	✓	✓
2½	#7	GR03	1000	SSDTH212SGR03	✓	✓
2½	#7	TN04	1000	SSDTH212STN04	✓	✓
2½	#7	TN03	1000	SSDTH212STN03	✓	✓
2½	#7	WH02	1000	SSDTH212SWH02	✓	✓
2½	#7	BR03	1000	SSDTH212SBR03	✓	✓
2½	#7	RD02	1000	SSDTH212SRD02	✓	✓
2½	#7	BR04	1000	SSDTH212SBR04	✓	✓
2½	#7	GR02	1000	SSDTH212SGR02	✓	✓
2½	#7	WH01	1000	SSDTH212SWH01	✓	✓



See pages 20-21 for Color Reference Chart for Decking Manufacturers

Collated Screws for the Quik Drive® System

Trim-Head Decking Screw – Type-17 Point

Features:

- Trim head with nibs for easy countersinking
- #2 undersized square drive (driver bit in each box; replacement bit model BIT2SU)
- Coarse threads
- Curved collation

Quik Guard® Coating

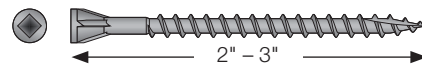

Length (in.)	Shank Size	Retail Pack		Contractor Pack		PRO 200	PRO 200S	PRO 250	PRO 300S
		Fasteners Per Pack	Model No.	Fasteners Per Pack	Model No.				
2	#8	1000	HCKDTHQ2S	2000	DTHQ2S	✓	✓	✓	✓
2½	#8	750	HCKDTHQ212S	1500	DTHQ212S			✓	✓
3	#8	500	HCKDTHQ3S	1000	DTHQ3S				✓

These coated fasteners possess a level of corrosion resistance that makes them suitable for use in some exterior and corrosive environments and with some preservative-treated woods. For applications in higher-exposure applications, consider Type-300 series stainless-steel fasteners for superior corrosion resistance. See page 15 for additional important information before selecting a fastener for a specific application.



Collated Exterior Wood Screws

SS3DSC Bugle-Head Wood Decking Screw

Common Applications:

Wood decking to wood

Features:

- #3 square drive (driver bit in each box; replacement bit model BIT3S)
- Coarse threads
- Type-17 point
- Available in Types 316 and 305 stainless steel
- Curved collation

Type 316 Stainless Steel

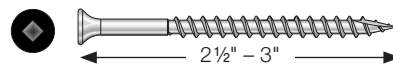

Length (in.)	Shank Size	Carton Quantity	Model No.	PRO300S
2½	#10	1500	SS3DSC212BS316	✓
3	#10	1000	SS3DSC3BS316	✓

Type 305 Stainless Steel

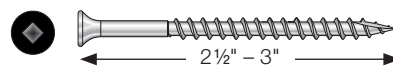

Length (in.)	Shank Size	Carton Quantity	Model No.	PRO300S
2½	#10	1500	SS3DSC212BS	✓
3	#10	1000	SS3DSC3BS	✓

CB3BLG Fiber-Cement Board Screw

Common Applications:

Dense fiber-cement board to wood

Features:

- 0.375" ribbed wafer head with nibs for easy countersinking
- #3 undersized square drive (driver bit in each box; replacement bit model BIT3SU)
- Coarse threads
- Type-17 point
- C-3 mechanically-galvanized coating
- Straight collation

Codes/Standards: ANSI A108 compliant

C-3 Mechanically-Galvanized Coating

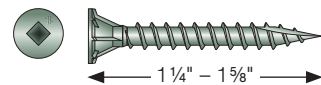

Length (in.)	Shank Size	Threads Per Inch	Retail Pack		Contractor Pack		PRO LDH
			Fasteners Per Pack	Model No.	Fasteners Per Pack	Model No.	
1¼	#10	10	500	HCKCB3BLG114S	1500	CB3BLG114S	✓
1½	#10	10	500	HCKCB3BLG158S	1500	CB3BLG158S	✓



Collated Exterior Wood Screws

CB3BLGHL Cement Board Screw

Common Applications:

Cement board to wood (for coarse, porous and softer materials)

Features:

- 0.375" ribbed wafer head with nibs for easy countersinking
- #3 undersized square drive (driver bit in each box; replacement bit model BIT3SU)
- Alternating high-low threads
- Sharp point
- C-3 mechanically-galvanized coating
- Straight collation

Codes/Standards: ANSI A108 compliant

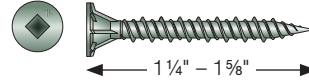

C-3 Mechanically-Galvanized Coating

Length (in.)	Shank Size	Threads Per Inch	Retail Pack		Contractor Pack		PRO LDH
			Fasteners Per Pack	Model No.	Fasteners Per Pack	Model No.	
1 1/4	#9	15 High-Low	500	HCKCB3BLGHL114S	1500	CB3BLGHL114S	✓
1 5/8	#9	15 High-Low	500	HCKCB3BLGHL158S	1500	CB3BLGHL158S	✓



Collated Exterior Wood Screws

DWC Drywall Screw

Common Applications:

Drywall to wood

Features:

- Bugle head
- #2 Phillips (driver bit in each box; replacement bit model BIT2P)
- Coarse threads
- Sharp point
- Curved collation

Codes/Standards: ASTM C1002-04 Type W

N2000® Coating

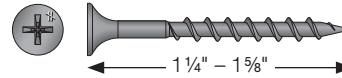

Length (in.)	Shank Size	Retail Pack		Contractor Pack		PRO 200
		Fasteners Per Pack	Model No.	Fasteners Per Pack	Model No.	
1¼	#6	—	—	2500	DWCG114PS	✓
1½	#6	—	—	2500	DWCG158PS	✓

These coated fasteners possess a level of corrosion resistance that makes them suitable for use in some exterior and corrosive environments and with some preservative-treated woods. For applications in higher-exposure applications, consider Type-300 series stainless-steel fasteners for superior corrosion resistance. See page 15 for additional important information before selecting a fastener for a specific application.



Collated Exterior Wood Screws

HJ Metal Roofing/Siding Panel Screw

Common Applications:
Metal roofing/siding panels to wood

Features:

- ¼" hex head
- EPDM-backed washer
- Sharp point
- JS500 plating system
- Powder-coated head and washer
- Available in a variety of stock colors to match almost any roofing panel (see page 181), custom colors available upon request
- Belt collation for BGP300

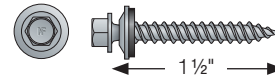

JS500 Plating

Length (in.)	Shank Size	Carton Quantity	Model No.	BGP300
1 ½	#10	500	HJ112WT10	✓

Collated Screws for the Quik Drive® System

HG Metal Roofing/Siding Panel Screw

Common Applications:
Metal roofing/siding panels to wood

Features:

- ¼" hex head
- EPDM-backed washer
- Type-17 point for timber and light-steel battens
- Belt collated for the Quik Drive® BGP300 System
- Strip collated for the Quik Drive® HX14 System
- Available in colors for HX14 System Only

Codes/Standards: Miami-Dade Fastener Listing 08-1110.06

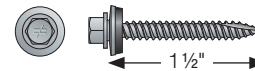

Mechanically Galvanized-Class-55

Length (in.)	Shank Size	Carton Quantity	Model No.	BGP300	HX14
1 ½	#10	1000	HG112WT10	✓	
1 ½	#10	1000	HG112WS		✓

These coated fasteners possess a level of corrosion resistance that makes them suitable for use in some exterior and corrosive environments and with some preservative-treated woods. For applications in higher-exposure applications, consider Type-300 series stainless-steel fasteners for superior corrosion resistance. See page 15 for additional important information before selecting a fastener for a specific application.



Collated Exterior Wood Screws

Color Guide for HJ/HG

Our collated hex-head fasteners are available in a variety of stock colors to match a wide variety of roofing panels. The color samples shown below are for reference only and shows the range of colors available. 1/4" hex head.

Color	HJ Part Number	HG Part Number
Bright White	HJ112WT10-0105	HG112WSBRWHITE
Medium Green	HJ112WT10-0402	HG112WSMDGREEN
Dark Green	HJ112WT10-0434	HG112WSDKGREEN
Red	HJ112WT10-0701	HG112WSRED
Bright Red	HJ112WT10-0703	HG112WSBRRED
Gray	HJ112WT10-1005	HG112WSGRAY
Dark Gray	HJ112WT10-1006	HG112WSDKGRAY
Brown	HJ112WT10-1103	HG112WSBROWN
Tan	HJ112WT10-1106	HG112WSTAN
Saddle Tan	HJ112WT10-1107	HG112WSSADDLE
Special Order	HJ112WT10-X	HG112WSX
Class 55	HG112WT10	HG112WS

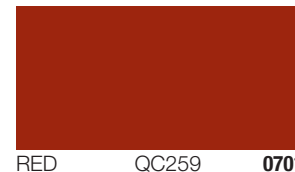
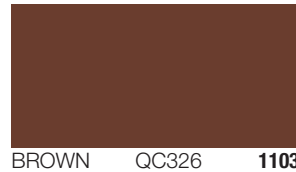

In Canada, QC number codes reference the recognized color system of coil coater Baycoat Inc. in Hamilton, Ontario.

How to Order Fasteners for the BGP300G2

1. Select your fastener from the previous page 180, noting its model number in the table. Example: HJ112WT10
2. Select a color from the chart above, noting the color code under the right corner of the paint chip (in bold). Example: BRWHITE 0105
3. Add the color code to the end of the fastener model number to designate the color. Example model number with color code: HJ112WT10-0105



Collated Exterior Wood Screws

PC Standing-Seam-Roofing Panel Clip Screw

Common Applications:

Standing-seam-roofing panel clips to wood

Features:

- Pancake head
- #2 square drive (driver bit in each box; replacement bit model BIT2SU)
- Type-17 point
- Straight collation

Codes/Standards: ASTM C1513 compliant

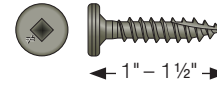

Quik Guard® Coating

Length (in.)	Shank Size	#2 Drive Type	Threads Per Inch	Carton Quantity	Model No.	PRO PP150
1	#10	Undersized	12	1500	PCQ1BS1012	✓
1½	#10	Undersized	12	1500	PCQ112BS1012	✓
1	#12	Undersized	11	1500	PCQ1BS1211	✓

WARNING: Industry studies show that hardened fasteners can experience performance problems in wet or corrosive environments. Accordingly, use this product in dry, interior, and noncorrosive environments only.

- These coated fasteners possess a level of corrosion resistance that makes them suitable for use in some exterior and corrosive environments and with some preservative-treated woods. For applications in higher-exposure applications, consider Type-300 series stainless-steel fasteners for superior corrosion resistance. See page 15 for additional important information before selecting a fastener for a specific application.

Collated Screws for the Quik Drive® System



Collated Exterior Wood Screws

PCULP Standing-Seam-Roofing Panel Clip Screw

Common Applications:

Standing-seam-roofing (or "snap and seam") panels to wood

Features:

- Ultra low profile pancake head
- #2 square drive (driver bit in each box; replacement bit model BIT2SU)
- Type-17 point
- Straight collation

Codes/Standards: ASTM C1513 compliant

Quik Guard® Coating

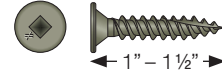

Length (in.)	Shank Size	#2 Drive Type	Threads Per Inch	Carton Quantity	Model No.	PRO PP150
1	#10	Undersized	12	1500	PCULPQ1BS1012	✓
1½"	#10	Undersized	12	1500	PCULPQ112BS1012	✓

WARNING: Industry studies show that hardened fasteners can experience performance problems in wet or corrosive environments. Accordingly, use this product in dry, interior, and noncorrosive environments only.

- These coated fasteners possess a level of corrosion resistance that makes them suitable for use in some exterior and corrosive environments and with some preservative-treated woods. For applications in higher-exposure applications, consider Type-300 series stainless-steel fasteners for superior corrosion resistance. See page 15 for additional important information before selecting a fastener for a specific application.



Collated Exterior Wood Screws

WSC Wood Screw

Common Applications:

Wood to wood

Features:

- Flat head with nibs under the head for easier countersinking
- #2 square drive, (replacement bit models BIT2SU)
- Coarse threads
- Curved collation

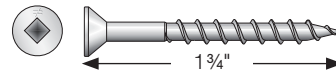

N2000® Coating

Length (in.)	Shank Size	Point Type	Drive Type	Carton Quantity	Model No	PRO200S	PRO250	PRO300S
1 3/4	#8	Sharp Point	Standard	2000	WSCG134S	✓	✓	✓

SSWSCB Roofing Tile Screw

Common Applications:

Roofing tiles to wood

Features:

- Bugle head
- #2 square drive (driver bit in each box; replacement bit model BIT2S)
- Coarse threads
- Type-17 point
- Curved collation

Codes/Standards: Meets the requirements of the Tile Roofing Institute as described in ESR-2015P. A Miami-Dade compliant roofing product (2" and 2 1/2" only).

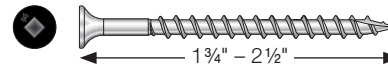

Type 305 Stainless Steel

Length (in.)	Shank Size	Carton Quantity	Model No.	PRO RF	PRO 300SRF
1 3/4	#8	2000	SSWSC134BS	✓	✓
2	#8	2000	SSWSC2BS	✓	✓
2 1/2	#8	1500	SSWSC212BS	✓	✓



Collated Exterior Wood Screws

WSCD Roofing Tile Screw

Common Applications:

Roofing tiles to wood

Features:

- Flat head
- #3 square drive (driver bit in each box; replacement bit model BIT3SU)
- Twin threads
- Sharp point
- Curved collation

Codes/Standards: Meets the requirements of the Tile Roofing Institute as described in ESR-2015P. Miami-Dade Fastener Listing 10-0330.06

Mechanically Galvanized – Class 55

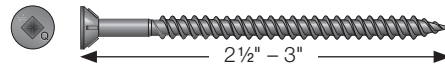

Length (in.)	Shank Size	Carton Quantity	Model No.	PRO RF	PRO 300SRF
2½	#8	1500	WSCD212S	✓	✓
3	#8	1000	WSCD3S		✓

WSCT Roofing Tile Screw

Common Applications:

Roofing tiles to wood

Features:

- Flat head
- #3 square drive (driver bit in each box; replacement bit model BIT3S)
- Twin threads
- Sharp point
- Curved collation

Codes/Standards: ASTM A641 (Class 1)

Heavy Zinc Electroplate

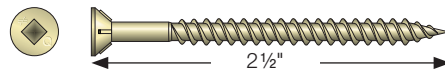

Length (in.)	Shank Size	Carton Quantity	Model No.	PRO RF	PRO 300SRF
2½	#8	1500	WSCT212S	✓	✓

These coated fasteners possess a level of corrosion resistance that makes them suitable for use in some exterior and corrosive environments and with some preservative-treated woods. For applications in higher-exposure applications, consider Type-300 series stainless-steel fasteners for superior corrosion resistance. See page 15 for additional important information before selecting a fastener for a specific application.

C-F-14 ©2014 SIMPSON STRONG-TIE COMPANY INC. (This page has been updated since printing)

Collated Screws for the Quik Drive® System

Collated Composite Decking Screws



Composi-Lok™ Composite-Decking Screw

Composite Decking used in Decks and Docks

Features:

- Cap head
- #2 square drive. Driver bit in each box; replacement bit model BIT2SU (BIT2S for stainless steel versions)
- Wings on shaft help prevent screw “spinout”
- Sharp point
- Curved collation
- This screw is also available in bulk for hand-drive installation. See page 76 for details.

For information on corrosion, materials and coatings, see page 15.

Painted

Quik Guard® Coating

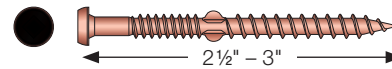

Length (in.)	Shank Size	Color	Retail Pack		Contractor Pack		PRO 250	PRO 300S
			Fasteners Per Pack	Model No.	Fasteners Per Pack	Model No.		
2½	#9	Brown	500	HCKDCLB212S	1000	DCLB212S	✓	✓
2½	#9	Gray	500	HCKDCLG212S	1000	DCLG212S	✓	✓
2½	#9	Red	500	HCKDCLR212S	1000	DCLR212S	✓	✓
2½	#9	Tan	500	HCKDCLT212S	1000	DCLT212S	✓	✓
3	#9	Brown	500	HCKDCLB3S	1000	DCLB3S		✓
3	#9	Gray	500	HCKDCLG3S	1000	DCLG3S		✓
3	#9	Red	500	HCKDCLR3S	1000	DCLR3S		✓
3	#9	Tan	500	HCKDCLT3S	1000	DCLT3S		✓



See pages 20-21 for Color Reference Chart for Decking Manufacturers

Unpainted

Type 316 Stainless Steel

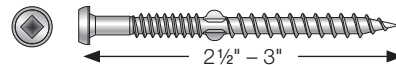

Length (in.)	Shank Size	Color	Retail Pack		Contractor Pack		PRO 250	PRO 300S
			Fasteners Per Pack	Model No.	Fasteners Per Pack	Model No.		
3	#9	Unpainted	—	—	1000	SSDCL3S316		✓

Type 305 Stainless Steel

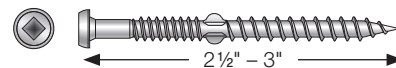

Length (in.)	Shank Size	Color	Retail Pack		Contractor Pack		PRO 250	PRO 300S
			Fasteners Per Pack	Model No.	Fasteners Per Pack	Model No.		
2½	#9	Unpainted	500	HCKSSDCL212S	1000	SSDCL212S	✓	✓
3	#9	Unpainted	500	HCKSSDCL3S	1000	SSDCL3S		✓

These coated fasteners possess a level of corrosion resistance that makes them suitable for use in some exterior and corrosive environments and with some preservative-treated woods. For applications in higher-exposure applications, consider Type-300 series stainless-steel fasteners for superior corrosion resistance. See page 15 for additional important information before selecting a fastener for a specific application.

Collated Screws for the Quik Drive® System

Collated Composite Decking Screws



Deck-Drive™

DCSD COMPOSITE-TO-STEEL Screw

Composite Decking to Steel Deck Framing

Features:

- Drives easily through double 14ga. steel box beam without pre-drilling
- Provides a clean, finished deck surface with no mushrooming
- The Quik Drive® system holds the screw securely as it drills through the metal joist for a more consistent installation
- #2 square drive (replacement bit BIT2SU, see page 264 for more information)

See pages 20-21 for Color Reference Chart for Decking Manufacturers

Screw design is patent pending

Approved fastener (by Trex) for Trex® Elevations™

Quik Guard® Coating

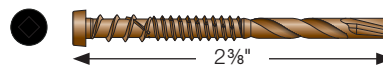

Length (in.)	Size	Color	Quik Drive part # (1000 ct)	Use with Trex® Color <small>(Colors will also match other major composite decking manufacturers)</small>	PRO 250	PRO 300S
2 3/8	#10	Brown 01	DCSD238SBR01	Vintage Lantern	✓	✓
2 3/8	#10	Tan 01	DCSD238STN01	Tree House, Saddle, Spiced Rum, Tiki Torch, Barrel	✓	✓
2 3/8	#10	Gray 01	DCSD238SGR01	Gravel Path	✓	✓
2 3/8	#10	Red 01	DCSD238SRD01	Lava Rock, Fire Pit	✓	✓
2 3/8	#10	Gray 04	DCSD238SGR04	Flint, Select Winchester Gray	✓	✓
2 3/8	#10	Tan 02	DCSD238STN02	Rope Swing	✓	✓

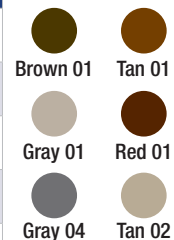

These coated fasteners possess a level of corrosion resistance that makes them suitable for use in some exterior and corrosive environments and with some preservative-treated woods. For applications in higher-exposure applications, consider Type-300 series stainless-steel fasteners for superior corrosion resistance. See page 15 for additional important information before selecting a fastener for a specific application.



Collated Interior Wood Screws

Strong-Drive® WSNTL SUBFLOOR Screw

For Subfloor and Sheathing to wood, Multi-Ply Wood Members
Code-Listed, Collated Screws Exceed Values of 10d Nails

WSNTL wood screws are ideal for fastening subfloor, sheathing, sill plate and stair tread applications using the Simpson Strong-Tie® Quik Drive® auto-feed screw driving system. With lateral shear, withdrawal and pull-through values that exceed those of 10d common nails, the holding power of WSNTL screws reduces the gaps between the joist and subfloor that cause floor squeaks. Installing WSNTL wood screws removes the need for gluing in diaphragm applications, which eliminates the precise timing, labor and materials that the process requires. Using screws that can be backed out easily allows future access to floor cavities.

Common Applications:

Subfloor and sheathing to wood and EWP, Ply fastening for multi-ply trusses

Features:

- Eliminates subfloor nail squeaking and costly call-backs
- Variety of lengths to cover subfloor, wall plates, and stair treads
- #3 Square drive (driver bit in each box; replacement bit model BIT3S)

Codes/Standards: ICC-ES ESR-1472; City of L.A. RR25661; Florida FL 13731
(Note: 1 3/4" length not code listed)

For Technical Data and Loads, see pages 308-311
For information on corrosion, materials and coatings, see page 15

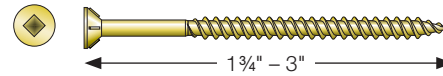

Yellow-Zinc Coating

Length (in.)	Shank Size	Retail Pack		Contractor Pack		PRO 200S	PRO 250	PRO 300S
		Fasteners Per Pack	Model No.	Fasteners Per Pack	Model No.			
1 3/4	#8	1000	HCKWSNTL134S	2000	WSNTL134S	✓	✓	✓
2	#8	1000	HCKWSNTL2LS	2000	WSNTL2LS	✓	✓	✓
2 1/2	#8	750	HCKWSNTL212S	1500	WSNTL212S		✓	✓
3	#8	500	HCKWSNTL3S	1000	WSNTL3S			✓

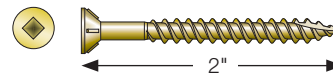

Yellow-Zinc Coating

Length (in.)	Shank Size	Retail Pack		Contractor Pack		PRO 200S	PRO 250	PRO 300S
		Fasteners Per Pack	Model No.	Fasteners Per Pack	Model No.			
2	#8	—	—	2000	WSNTL2LS-17	✓	✓	✓

Holding Power of Typical Sheathing Fasteners as Compared to WSNTL2LS

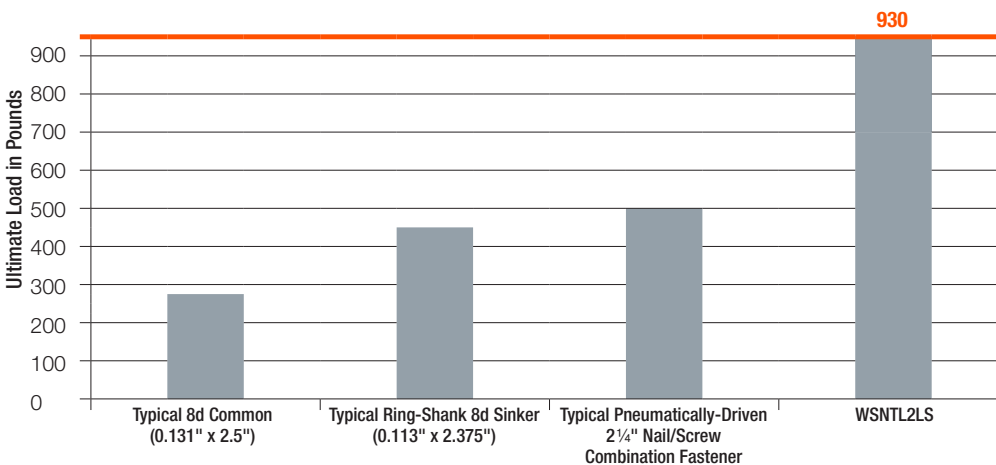

1. Chart based on resultant penetration of the attachment of 1 9/32" thick sheathing with a Douglas Fir main member.
2. 8d common ultimate loads are based on National Design Specification design and then multiplied by a factor of safety of 5.
3. 8d sinker ring, nail/screw combination and WSNTL fasteners withdrawal load based on withdrawal testing in accordance with ICC-ES AC 233, ICC-ES AC 116 and ASTM D1761.

Collated Screws for the Quik Drive® System



Collated Interior Wood Screws

“Hear” the Difference over Time

Squeaking of newly installed floors can result in expensive (travel, labor, materials) callbacks and possibly a damaged reputation. Fastening subflooring with WSNTL wood screws rather than pneumatic fasteners provides the power necessary to pull together joists and plywood (or WSP sheathing), eliminating any gaps, holding the materials firm and therefore reducing squeaks.

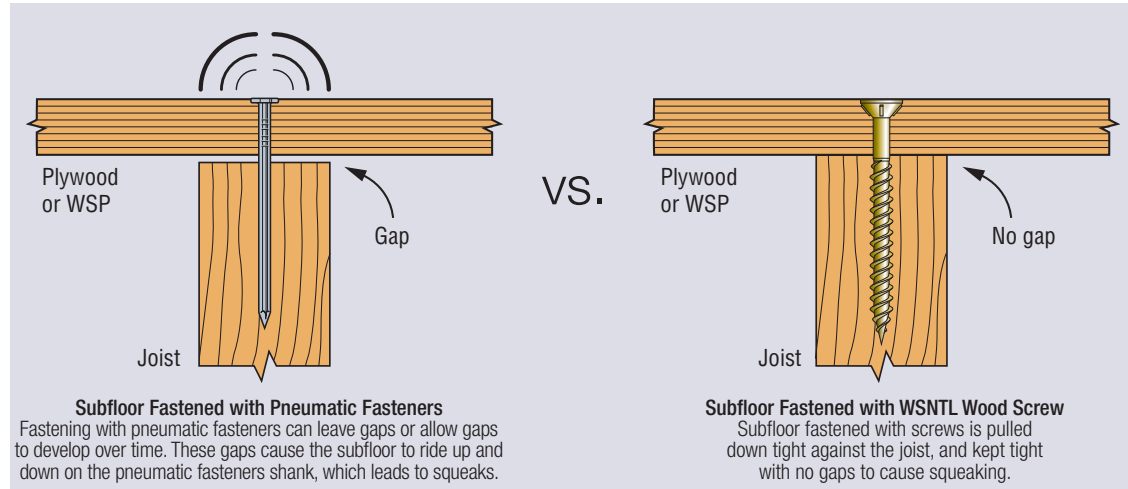

“See” the Difference on the Jobsite

The WSNTL wood screw gives visual confirmation of a secure joist connection by countersinking, while “shot-in” pneumatic fasteners look the same whether or not they hit the joist. Missed fasteners could result in floor flexing that can cause squeaking in other parts of the structure and reduced diaphragm load capacity.

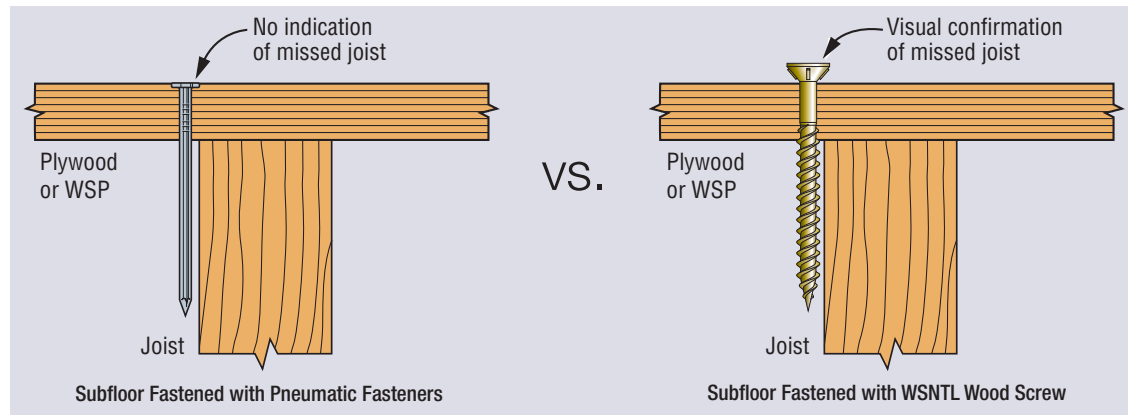



Collated Interior Wood Screws

WSHL Subfloor Screw

Common Applications:

Subfloor to wood

Features:

- Ribbed flat head with nibs for easy countersinking
- #2 square drive (driver bit in each box; replacement bit model BIT2S)
- High-low threads
- Sharp point
- Gray-phosphate coating
- Curved collation
- 1:1 replacement for 8d common nails when used with floor sheathing 1⁵/₃₂-2³/₃₂" thick



Gray-Phosphate Coating

Length (in.)	Shank Size	Carton Quantity	Model No.	PRO 200S	PRO 250	PRO 300S
1 3/4	#7	2000	WSHL134S7	✓	✓	✓
1 3/4	#7	1000	HCKWSHL134S7	✓	✓	✓

Collated Screws for the Quik Drive® System

DWC Drywall Screw

Common Applications:

Drywall to wood

Features:

- Bugle head
- #2 Phillips (driver bit in each box; replacement bit model BIT2P)
- Coarse threads
- Sharp point
- Curved collation

Codes/Standards: ASTM C1002-04 Type W

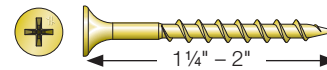

Yellow-Zinc Coating

Length (in.)	Shank Size	Retail Pack		Contractor Pack		PRO 200
		Fasteners Per Pack	Model No.	Fasteners Per Pack	Model No.	
1 1/4	#6	—	—	2500	DWCZ114PS	✓
1 5/8	#6	—	—	2500	DWCZ158PS	✓
2	#6	—	—	2000	DWCZ2PS	✓



Gray-Phosphate Coating

Length (in.)	Shank Size	Retail Pack		Contractor Pack		PRO 200	PRO 250DW
		Fasteners Per Pack	Model No.	Fasteners Per Pack	Model No.		
1	#6	—	—	2500	DWC1PS	✓	
1 1/4	#6	1000	HCKDWC114PS	2500	DWC114PS	✓	
1 5/8	#6	1000	HCKDWC158PS	2500	DWC158PS	✓	
2	#6	—	—	2000	DWC2PS	✓	✓
2 1/2	#8	—	—	1500	DWC212PS		✓



Collated Interior Wood Screws

DWHL Drywall Screw

Common Applications:

Drywall to wood

Features:

- Bugle head
- #2 Phillips drive (driver bit in each box; replacement bit model BIT2P)
- High-low threads
- Sharp point
- Gray-phosphate coating
- Curved collation

Gray-Phosphate Coating

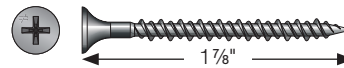

Length (in.)	Shank Size	Carton Quantity	Model No.	PRO 250DW	PRO 200
1 7/8	#6	2000	DWHL178PS	✓	✓

MTH Wood Underlayment Screw

Common Applications:

Wood underlayment to wood

Features:

- Trim head with nibs for easy countersinking
- #2 square drive (driver bit in each box; replacement bit model BIT2S)
- High-low threads
- Sharp point
- Curved collation

Yellow-Zinc Coating

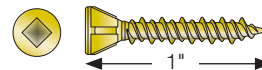

Length (in.)	Shank Size	Coating	Retail Pack		Contractor Pack		PRO 200	PRO 200S
			Fasteners Per Pack	Model No.	Fasteners Per Pack	Model No.		
1	#7	Yellow Zinc	—	—	2500	MTHZ1S	✓	✓

Gray-Phosphate Coating

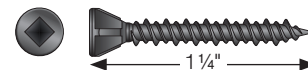

Length (in.)	Shank Size	Coating	Retail Pack		Contractor Pack		PRO 200	PRO 200S
			Fasteners Per Pack	Model No.	Fasteners Per Pack	Model No.		
1 1/4	#7	Gray Phosphate	1000	HCKMTH114S	2500	MTH114S	✓	✓



Collated Interior Wood Screws

PC Standing Seam Roofing Panel Clip Screw

Common Applications:

Standing-seam-roofing panel clips to wood

Features:

- Pancake head
- #2 square drive (driver bit in each box; replacement bit model BIT2S)
- Type-17 point
- Straight collation
- Type 410 stainless steel is coated for additional corrosion protection

Type 410 Stainless Steel

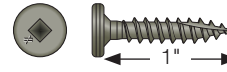

Length (in.)	Shank Size	#2 Drive Type	Threads Per Inch	Carton Quantity	Model No.	PRO PP150
1	#10	Standard	12	1500	SSPC1BS1012	✓

Clear -Zinc Coating

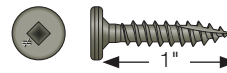

Length (in.)	Shank Size	#2 Drive Type	Threads Per Inch	Carton Quantity	Model No.	PRO PP150
1	#10	Standard	12	1500	PC1BS1012	✓
1	#12	Standard	11	1500	PC1BS1211	✓

PCULP Standing-Seam-Roofing Panel Clip Screw

Common Applications:

Standing-seam-roofing (or "snap and seam") panels to wood

Features:

- Ultra low profile pancake head
- #2 square drive (driver bit in each box; replacement bit model BIT2S)
- Type-17 point
- Straight collation
- Type 410 stainless steel is coated for additional corrosion protection

Codes/Standards: ASTM C1513 compliant

Type 410 Stainless Steel

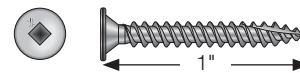

Length (in.)	Shank Size	#2 Drive Type	Threads Per Inch	Carton Quantity	Model No.	PRO PP150
1	#10	Standard	12	1500	SSPCULP1BS1012	✓

Clear-Zinc Coating

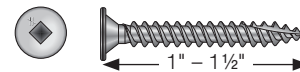

Length (in.)	Shank Size	#2 Drive Type	Threads Per Inch	Carton Quantity	Model No.	PRO PP150
1	#10	Standard	12	1500	PCULP1BS1012	✓
1 1/2	#10	Standard	12	1500	PCULP112BS1012	✓

WARNING: Industry studies show that hardened fasteners can experience performance problems in wet or corrosive environments. Accordingly, use this product in dry, interior, and noncorrosive environments only.



Collated Interior Wood Screws

PHSS Wood Screw

Common Applications:

Wood to wood

Features:

- Pan head
- #2 square drive (driver bit in each box; replacement bit model BIT2S)
- Twin threads
- Sharp point
- Yellow-zinc coating
- Curved collation

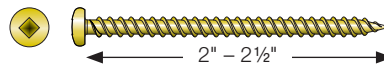

Yellow-Zinc Coating

Length (in.)	Shank Size	Carton Quantity	Model No.	PRO 250	PRO 300S
2	#8	2000	PHSS2S	✓	✓
2½	#8	1500	PHSS212S	✓	✓

WSC Wood Screw

Common Applications:

Wood to wood

Features:

- Flat head with nibs for easy countersinking
- #2 Square drive (driver bit in each box; replacement bit model BIT2S)
- Coarse threads
- Available with type-17 and sharp points
- Curved collation

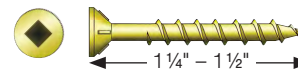

Yellow-Zinc Coating

Length (in.)	Shank Size	Point Type	Carton Quantity	Model No.	PRO 200S	PRO 250
1¼	#8	Type 17	2500	WSC114S-17	✓	
1½*	#8	Sharp	2000	WSC112S	✓	✓

* This size does not have nibs under the head.

WSCLT Wood Screw

Common Applications:

Wood to wood

Features:

- Flat head
- #2 square drive (driver bit in each box; replacement bit model BIT2S)
- Coarse threads
- Sharp point
- Yellow-zinc coating
- Curved collation
- Fully threaded

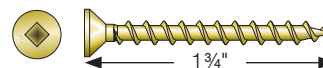

Yellow-Zinc Coating

Length (in.)	Shank Size	Carton Quantity	Model No.	PRO 200S	PRO 250	PRO 300S
1¾	#8	2000	WSCLT134S	✓	✓	✓



Collated Metal Screws

Strong-Drive® TB WOOD-TO-STEEL Screw

Common Applications:

Wood to hot-rolled steel (Maximum recommended thicknesses: 5/16")

Features:

- Flat head with nibs for easy countersinking
- #3 square drive (driver bit in each box; replacement bit model BIT3S; use BIT3SU for Mechanically Galvanized – N2000®)
- #4 drill point with wings
- Straight collation

For Technical Data and Loads, see page 307

WARNING: Industry studies show that hardened fasteners can experience performance problems in wet or corrosive environments. Accordingly, use this product in dry, interior, and noncorrosive environments only

Mechanically Galvanized – N2000®

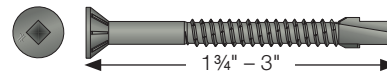

Length in. (mm)	Shank Size	Threads Per Inch	Carton Quantity	Model No.	PRO HSD60	PRO HSD75
1 3/4 (45)	#12	14	1000	TBG1245S	✓	
2 3/8 (60)	#12	14	1000	TBG1260S	✓	✓
1 3/4 (45)	#14	14	1000	TBG1445S	✓	
2 3/8 (60)	#14	14	750	TBG1460S	✓	✓
3 (75)	#14	14	750	TBG1475S		✓

Yellow-Zinc Coating

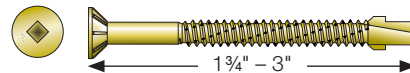

Length in. (mm)	Shank Size	Threads Per Inch	Carton Quantity	Model No.	PRO HSD60	PRO HSD75
1 3/4 (45)	#14	14	1000	TB1445S	✓	
2 3/8 (60)	#14	14	750	TB1460S	✓	✓
3 (75)	#14	14	750	TB1475S		✓

Black-Phosphate Coating

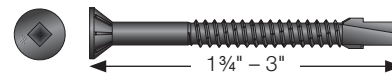

Length in. (mm)	Shank Size	Threads Per Inch	Carton Quantity	Model No.	PRO HSD60	PRO HSD75
1 3/4 (45)	#12	14	1000	TBP1245S	✓	
2 3/8 (60)	#12	14	1000	TBP1260S	✓	✓
2 3/8 (60)	#14	14	750	TBP1460S	✓	✓
3 (75)	#14	14	750	TBP1475S		✓

These coated fasteners possess a level of corrosion resistance that makes them suitable for use in some exterior and corrosive environments and with some preservative-treated woods. For applications in higher-exposure applications, consider Type-300 series stainless-steel fasteners for superior corrosion resistance. See page 15 for additional important information before selecting a fastener for a specific application.

Collated Screws for the Quik Drive® System



Collated Metal Screws

Strong-Drive® PHSD FRAMING-TO-CFS Screw

Common Applications:

Cold-formed steel framing and sheet steel sheathing to cold-formed steel

Features:

- Pan head
- #2 drill point
- #2 square drive (driver bit in each box; replacement bit model BIT2S)
- Clear-zinc coating
- Straight collation

Codes/Standards: ASTM C1513 compliant, City of LA RR25670

For Technical Data and Loads, see page 314

Clear-Zinc Coating

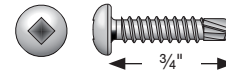

Length (in.)	Shank Size	Threads Per Inch	Point Size	Carton Quantity	Model No.	PRO PH
3/4	#8	18	2	2500	PHSD34S0818	✓

Strong-Drive® FPHSD FRAMING-TO-CFS Screw

Common Applications:

Cold-formed steel framing and sheet steel sheathing to cold form steel

Features:

- Flat pan head
- #3 square drive (driver bit in each box; replacement bit model BIT3S)
- #3 drill point
- Clear-zinc coating
- Straight collation
- This screw is also available in bulk for hand-drive installation. See page 124 for details.

Codes/Standards: ASTM C1513 compliant

For Technical Data and Loads, see page 315

Clear-Zinc Coating

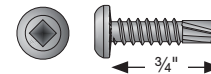

Length (in.)	Shank Size	Threads Per Inch	Point Size	Carton Quantity	Model No.	PRO SD150	PRO PH
3/4	#10	16	3	2500	FPHSD34S1016	✓	✓
3/4	#12	14	3	2500	FPHSD34S1214	✓	✓



Collated Metal Screws

Strong-Drive® PPSD SHEATHING-TO-CFS Screw

Common Applications:

Subfloor/sheathing to cold-formed steel, (#8 – maximum thickness: 54 mils/16 ga., #10, #12 – maximum thickness: 97 mils/12 ga.)

Features:

- Flat head
- #3 square drive (driver bit in each box; use replacement bit model BIT3SU for Quik Guard® and BIT3S for Yellow-Zinc Coating)
- Fine threads
- Pilot point
- Quik Guard® and yellow-zinc coating
- Curved collation
- #8 and #10 screws meet minimum head diameter requirement per AISI S213-07, lateral design standard
- This screw is also available in bulk for hand-drive installation. See page 123 for details.

Available Coatings: ASTM C1513 compliant

For Technical Data and Loads, see page 313

WARNING: Industry studies show that hardened fasteners can experience performance problems in wet or corrosive environments. Accordingly, use this product in dry, interior, and noncorrosive environments only

Collated Screws for the Quik Drive® System

Quik Guard® Coating

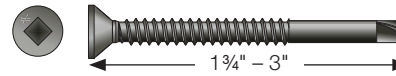

Length (in.)	Shank Size	Min. Head Diameter (in.)	Point Size	Threads per Inch	Carton Quantity	Model No.	PRO 200S	PRO 250	PRO 300S	HSD60	HSD75
1 15/16	#8	0.315	2	18	2000	PPSDQ11516S0818	✓	✓	✓		
1 3/4	#10	0.325	3	16	2000	PPSDQ134S1016	✓	✓	✓		
1 3/4	#12	0.452	3	14	1000	PPSDQ134S1214*				✓	✓
3	#10	0.325	3	16	1000	PPSDQ3S1016			✓		
3	#12	0.452	3	14	1000	PPSDQ3S1214*					✓

*Has underhead nibs.

Yellow-Zinc Coating

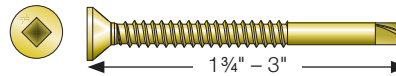

Length (in.)	Shank Size	Min. Head Diameter (in.)	Point Size	Threads per Inch	Carton Quantity	Model No.	PRO 200S	PRO 250	PRO 300S	HSD60	HSD75
1 15/16	#8	0.315	2	18	2000	PPSD11516S0818	✓	✓	✓		
1 3/4	#10	0.325	3	16	2000	PPSD134S1016	✓	✓	✓		
1 3/4	#12	0.452	3	14	1000	PPSD134S1214*				✓	✓
3	#10	0.325	3	16	1000	PPSD3S1016			✓		
3	#12	0.452	3	14	1000	PPSD3S1214*					✓

*Has underhead nibs.

These coated fasteners possess a level of corrosion resistance that makes them suitable for use in some exterior and corrosive environments and with some preservative-treated woods. For applications in higher-exposure applications, consider Type-300 series stainless-steel fasteners for superior corrosion resistance. See page 15 for additional important information before selecting a fastener for a specific application.



Collated Metal Screws

Self-Drilling X Metal Screw

Common Applications:

Steel decking to structural steel, steel stitching ("side-lap" stitching), cold-formed steel framing

Features:

- 5/16" hex head
- Drill point
- Hex washer head
- Straight collation
- This screw is also available in bulk for hand-drive installation. See page 125 for details.

Codes/Standards: ICC-ES ESR-3006, City of LA RR25670 and RR25917, ASTM C1513 compliant, FM Approval #3045651, SDI DDM03, Appendix VII, IAPMO-UES ER-326

For Technical Data and Loads, see pages 332-334

WARNING: Industry studies show that hardened fasteners can experience performance problems in wet or corrosive environments. Accordingly, use this product in dry, interior, and noncorrosive environments only

Quik Guard® Coating

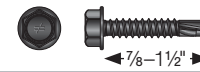

Length (in.)	Shank Size	Threads Per Inch	Point Size	Carton Quantity	Model No.	PRO HX516	PRO PP150	PRO SD150	Application(s)
1	#10	16	3	1500	XQ1S1016	✓	✓	✓	2, 3
1	#12	14	3	1500	XQ1S1214	✓	✓	✓	2, 3
7/8*	#12	24	4	1500	XQ78S1224	✓	✓	✓	1, 3
1 1/4*	#12	24	5	1500	XQ114S1224		✓	✓	1, 3
1 1/2*	#12	24	5	1500	XQ112S1224		✓	✓	1, 3

Clear-Zinc Coating

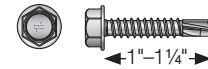

Length (in.)	Shank Size	Threads Per Inch	Point Size	Carton Quantity	Model No.	PRO HX516	PRO PP150	PRO SD150	Applications(s)
1	#10	16	3	1500	X1S1016	✓	✓	✓	2, 3
1	#12	14	3	1500	X1S1214	✓	✓	✓	2, 3
1 1/4"	#12	24	5	1500	X114S1224		✓	✓	1, 3

These coated fasteners possess a level of corrosion resistance that makes them suitable for use in some exterior and corrosive environments and with some preservative-treated woods. For applications in higher-exposure applications, consider Type-300 series stainless-steel fasteners for superior corrosion resistance. See page 15 for additional important information before selecting a fastener for a specific application

Save Time with our Steel Deck Diaphragm Calculator

Generate diaphragm shear tables for various roof and floor decks attached using Simpson Strong-Tie® X-series screws. Create shear strength tables in Nominal, ASD or LRFD for various deck spans. The tables are calculated based on Steel Deck Institute (SDI) Diaphragm Design Manual, Third Edition (DDM03). The factors of safety are based on Table D5 of AISI S100, North American Specification for the Design of Cold-formed Steel Members.

- Requires minimal input to generate the tables
- Generate tables for any Simpson support or side lap fastener combination.
- Create custom table with any support fastener pattern chosen
- Accounts for wind uplift demand
- Choose the first deck span in the table; total of 10 deck spans are shown in increments of 6 in. from the minimum span chosen.
- Produce custom tables for floor decks with any typical fill type
- Generate tables in Nominal, ASD Wind, LRFD Wind, or LRFD EQ or ASD EQ.

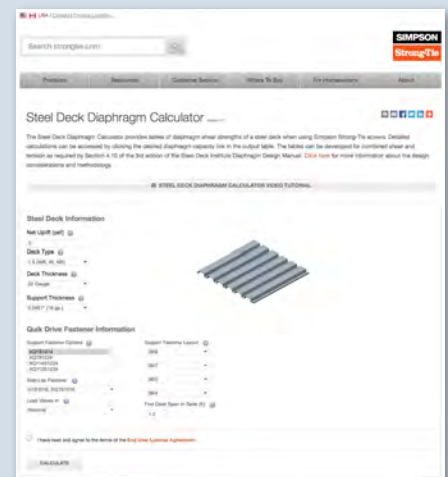

strongtie.com/diaphragmcalc





Collated Metal Screws

PCSD Standing-Seam Roofing Panel Clip Screw

Common Applications:

Standing-seam roofing panel clips to steel or sheet-steel sheathing to cold-formed steel

Features:

- Pancake head
- #2 square drive (driver bit included in each box; replacement bit BIT2S, see page 264 for more information)
- Drill point
- Straight collation
- Type 410 stainless steel is coated for additional corrosion protection
- This screw is also available in bulk for hand-drive installation. See page 126 for details.

Codes/Standards: ASTM C1513 compliant

WARNING: Industry studies show that hardened fasteners can experience performance problems in wet or corrosive environments. Accordingly, use this product in dry, interior, and noncorrosive environments only. For information on corrosion, materials and coatings, see page 15.

Quik Guard® Coating

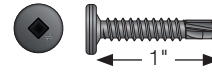

Length (in.)	Shank Size	#2 Drive Type	Threads Per Inch	Carton Quantity	Model No.	PRO PP150
1	#10	Undersized	16	1500	PCSDQ1S1016	✓
1	#12	Undersized	14	1500	PCSDQ1S1214	✓

Type 410 Stainless Steel

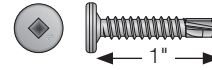

Length (in.)	Shank Size	#2 Drive Type	Threads Per Inch	Carton Quantity	Model No.	PRO PP150
1	#10	Standard	16	1500	SSPCSD1S1016	✓

Clear-Zinc Coating

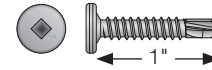

Length (in.)	Shank Size	#2 Drive Type	Threads Per Inch	Carton Quantity	Model No.	PRO PP150
1	#10	Standard	16	1500	PCSD1S1016	✓
1	#12	Standard	14	1500	PCSD1S1214	✓

These coated fasteners possess a level of corrosion resistance that makes them suitable for use in some exterior and corrosive environments and with some preservative-treated woods. For applications in higher-exposure applications, consider Type-300 series stainless-steel fasteners for superior corrosion resistance. See page 15 for additional important information before selecting a fastener for a specific application.

Collated Screws for the Quik Drive® System



Collated Metal Screws

CBSDQ Sheathing-to-CFS Screw

Common Applications:

Sheathing to cold-formed steel (Recommended thicknesses: 16 and 18 ga.)

Features:

- Ribbed flat head with nibs for easy countersinking
- #2 drill point with wings
- #2 undersized square drive (driver bit in each box; replacement bit model BIT2SU)
- Quik Guard® coating
- Curved collation

Codes/Standards: ASTM C1513 compliant, #8 screws meet minimum head diameter requirement per AISI S213-07, Lateral Design Standard.

For Technical Data and Loads, see page 331

WARNING: Industry studies show that hardened fasteners can experience performance problems in wet or corrosive environments. Accordingly, use this product in dry, interior, and noncorrosive environments only

Quik Guard® Coating

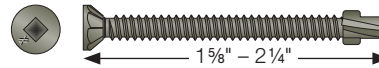

Length (in.)	Shank Size	Threads Per Inch	Point Size	Carton Quantity	Min. Head Dia. (in.)	Model No.	PRO 200S	PRO 250	PRO 300S
1 5/8	#8	18	2	1500	0.322	CBSDQ158S	✓	✓	✓
2 1/4	#10	16	2	1000	0.322	CBSDQ214S		✓	✓

These coated fasteners possess a level of corrosion resistance that makes them suitable for use in some exterior and corrosive environments and with some preservative-treated woods. For applications in higher-exposure applications, consider Type-300 series stainless-steel fasteners for superior corrosion resistance. See page 15 for additional important information before selecting a fastener for a specific application.

Collated Metal Screws

SIMPSON
Strong-Tie

DWF Drywall-to-CFS Screw

Common Applications:

Drywall to cold-formed steel (Recommended thicknesses: 33, 27 and 18 mils 20, 22 and 25 ga.)

Features:

- Bugle head
- #2 Phillips (driver bit in each box; replacement bit model BIT2P)
- Fine threads
- Sharp point
- Gray-phosphate coating
- Curved collation

Codes/Standards: ASTM C1002-04 Type S compliant

For Technical Data and Loads, see page 330

Gray-Phosphate Coating



Length (in.)	Shank Size	Carton Quantity	Model No.	PRO 200
1	#6	2500	DWF1PS	✓
1¼	#6	2500	DWF114PS	✓
1½	#6	2500	DWF158PS	✓

DWFSD Drywall-to-CFS Screw

Common Applications:

Drywall to cold-formed steel (Recommended max steel thicknesses: 54 and 43 mils/16 and 18 ga.)

Features:

- Bugle head
- #2 Phillips (driver bit in each box; replacement bit model BIT2P)
- Fine threads
- #2 drill point
- Curved collation

Codes/Standards: ASTM C954 compliant

For Technical Data and Loads, see page 330

Mechanically Galvanized – Class 55

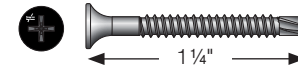

Length (in.)	Shank Size	Threads Per Inch	Box Quantity	Model No.	PRO 200S	PRO 200
1¼	#6	20	2500	DWFSDG114PS	✓	✓

Yellow-Zinc Coating

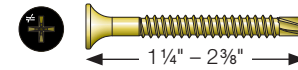

Length (in.)	Shank Size	Threads Per Inch	Box Quantity	Model No.	PRO 200S	PRO 250DW	PRO 200
1¼	#6	20	2500	DWFSD114PS	✓		✓
1½	#6	20	2500	DWFSD158PS	✓		✓
1¾	#6	20	2000	DWFSD178PS	✓	✓	✓
2¾	#8	20	1500	DWFSD238PS		✓	

These coated fasteners possess a level of corrosion resistance that makes them suitable for use in some exterior and corrosive environments and with some preservative-treated woods. For applications in higher-exposure applications, consider Type-300 series stainless-steel fasteners for superior corrosion resistance. See page 15 for additional important information before selecting a fastener for a specific application.



Collated Metal Screws

FHSD Wood-to-CFS Screw

Common Applications:

Wood or wood structural panel sheathing to cold-formed steel to cold formed steel (Recommended max steel thicknesses: 3/16")

Features:

- Flat head
- Curved collation
- Type 410 stainless-steel screw has nibs under the head for easy countersinking
- 2 1/2" length has wings on the shaft to prevent jacking of the wood panel during installation
- Type 410 stainless steel is coated for additional corrosion protection
- #3 square drive for #10 and #12 (replacement bit BIT3S, see page 264 for more information)
- #2 square drive for #8 (replacement bit BIT2S, see page 264 for more information)

Codes/Standards: ASTM C1513 compliant, Meets minimum head diameter requirements per AISI S213-07, lateral design standard.

For Technical Data and Loads, see page 331

Type 410 Stainless Steel

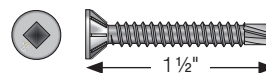

Length (in.)	Shank Size	Threads Per Inch	Point Size	Carton Quantity	Min. Head Dia. (in.)	Model No.	PRO PP150G2	PRO LDH
1 1/2	#10	16	3	1000	.382	SSFHSD112S1016	✓	✓

Yellow-Zinc Coating

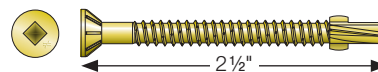

Length (in.)	Shank Size	Threads Per Inch	Point Size	Carton Quantity	Min. Head Dia. (in.)	Model No.	PRO HSD60
2 1/2	#12	14	4	750	.310	FHSD212S1214	✓

Yellow-Zinc Coating

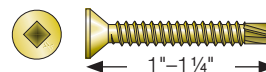

Length (in.)	Shank Size	Threads Per Inch	Point Size	Carton Quantity	Min. Head Dia. (in.)	Model No.	PRO 200S	PRO 200
1	#10	18	2	2500	.340	FHSD1S1018	✓	
1 1/4	#8	18	2	2500	.310	FHSD114S0818	✓	✓

WSFLRV Wood-to-CFS/Aluminum Screw

Common Applications:

Wood or wood structural panel sheathing to cold-formed steel (Recommended max steel thicknesses: 20 gauge), Wood to aluminum (Recommended max aluminium thicknesses: 3/16")

Features:

- Flat head with nibs for easy countersinking
- #3 square drive (driver bit in each box; replacement bit model BIT3S)
- Fine threads
- Type-17 point
- Yellow-zinc coating
- Curved collation

Codes/Standards: ASTM C1513 compliant, Meets AISI S213 minimum for sheathing attachment if t <= 54 mils.

For Technical Data and Loads, see page 331

Yellow-Zinc Coating

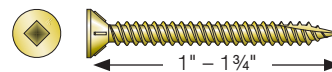

Length (in.)	Shank Size	Carton Quantity	Min. Head Dia. (in.)	Model No.	PRO 200S	PRO 200	PRO 250
1	#8	2500	0.327	WSF1LRVS	✓	✓	
1 3/4	#8	2000	0.327	WSF134LRVS	✓	✓	✓

Quik Drive® Screw Driving Systems



Quik Drive® auto-feed screw driving systems turn repetitive fastening into opportunities to increase efficiency and save time.

Extensive research goes into the design of each system and screw to understand the intended applications, fastener performance demands and the work flow in which installations take place. This results in professional-quality auto-feed solutions that truly make work easier.

- Auto-feed attachments and collated fasteners eliminate the need to handle individual screws
- Extensions allow stand-up driving for appropriate applications, making work faster and more comfortable
- Tool systems and fasteners specifically designed for target applications

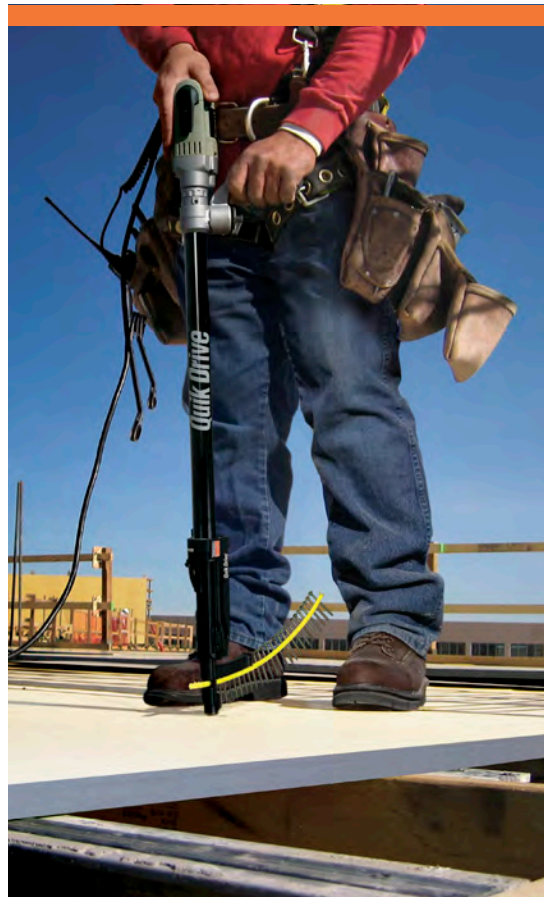

Subfloor/Sheathing Applications



Quik Drive® auto-feed screw driving systems are ideal for subfloor installation because they combine the efficiency of stand-up driving with the holding power of screws. Screws are superior to nails in this application because they reduce the gaps that cause floor squeaks.

Quik Drive Systems Applications

PRO250 System



- Expanded depth settings for high-density flooring materials
- Uniform toenailing and countersink on slick surfaces
- Reversible and replaceable non-skid teeth
- Details, page 239

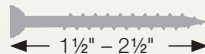

PROSDD Combo System



- Expanded depth settings for appropriate countersink in a variety of applications
- Includes both PRO300S Attachment and PRO200 Attachment for added versatility
- Reversible and replaceable non-skid teeth
- Sure-grip guide tube increases stability for a broad range of screws
- Details, page 257

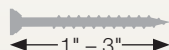

Subfloor/Sheathing Applications (cont.)





PROCCS+ Combo System

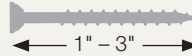

- Includes both PRO300S Attachment and PRO200S Attachment for added versatility
- Expanded depth settings for high-density flooring materials
- Reversible and replaceable non-skid teeth
- Sure-grip guide tube increases stability for a broad range of screws
- The patented curved collation strips (U.S. Patent 7,051,875) hold the screws up and away from the work surface, making moving and positioning the tool easier. They are also pointed on the inserted end to simplify loading.
- Details, page 258



Collated Screws for the Quik Drive® System

FASTENER MODEL	PR0250	PROSDD/CCS+	PR0300s
Strong-Drive® WSNTL SUBFLOOR Screw  Wood-to-wood applications, yellow-zinc coating, sharp-point, pages 188-189	1¾", 2", 2½"	1¾", 2", 2½", 3"	1¾", 2", 2½", 3"
Strong-Drive® WSNTL SUBFLOOR Screw  Wood-to-wood applications, yellow-zinc coating, Type-17 point, pages 188-189	2"	2"	2"
Strong-Drive® PPSD SHEATHING-TO-CFS Screw  Wood-to-steel applications, #2 drill point Quik Guard® and yellow-zinc coating, page 196	1¾", 1 15/16"	1¾", 1 15/16", 3"	1¾", 1 15/16", 3"
WSHL Subfloor Screw  Wood-to-wood applications, gray phosphate coating, page 190	1¾"	1¾"	1¾"
WSC Wood Screw  Wood-to-wood applications, yellow-zinc coating, coarse thread, page 193	1½"	1½"	1½"

Decks, Docks, and Boardwalks Applications

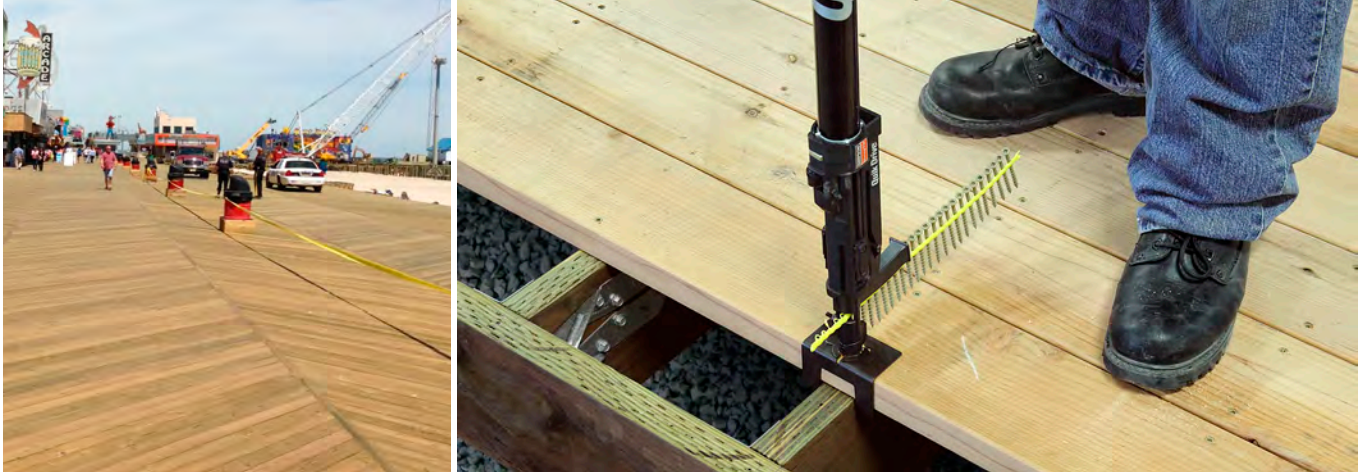

Quik Drive® auto-feed screw driving systems are ideal for fastening decking because they combine the efficiency of stand-up driving with the holding power of screws, providing the best long-term results.

Quik Drive Systems Applications

PRO300S System



Includes a decking nose clip to position decking screws quickly and precisely every time

- Expanded depth settings for appropriate countersink in a variety of applications
- Reversible and replaceable non-skid teeth
- Uniform toenailing and countersink on slick surfaces
- Sure-grip guide tube increases stability for a broad range of screws
- Details, page 240

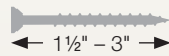

PROSDD Combo System





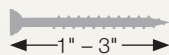



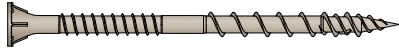
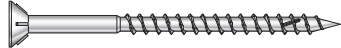

- Expanded depth settings for appropriate countersink in a variety of applications
- Includes both PRO300S Attachment and PRO200 Attachment for added versatility
- Reversible and replaceable non-skid teeth
- Uniform toenailing and countersink on slick surfaces
- Details, page 257



Decks, Docks, and Boardwalks Applications (cont.)

Collated Screws for the Quik Drive® System

FASTENER MODEL	PROSDD/CCS+	PRO300s
 <p>Deck-Drive™ DSV WOOD Screw</p> <p>Rimmed flat-head, Quik Guard coating, page 174</p>	2", 2½", 3"	2", 2½", 3"
 <p>Deck-Drive™ DWP WOOD SS Screw</p> <p>Types 316 and 305 stainless steel, page 174</p>	2½", 3"	2½", 3"
 <p>Deck-Drive™ DHPD HARDWOOD Screw</p> <p>Paddle-style drill point, Type 305 stainless steel, page 175</p>	2½"	2½"
 <p>Deck-Drive™ DCSD COMPOSITE-TO-STEEL Screw</p> <p>Drill point, Quik Guard coating, page 187</p>	2¾"	2¾"
 <p>Composi-Lok™ Composite-Decking Screw</p> <p>Composite-decking screw, Type 305 stainless steel and Quik Guard® coating, colors available, page 186</p>	2½", 3"	2½", 3"
 <p>Strong-Drive® WSNTL WOOD Screw</p> <p>Class 55 galvanized coating, page 175</p>	2", 2½", 3"	2", 2½", 3"
 <p>Strong-Drive® WSNTL WOOD Screw</p> <p>Quik Guard® coating, page 175</p>	2½", 3"	2½", 3"
 <p>SS3DSC Bugle-Head Wood Decking Screw</p> <p>Types 316 and 305 stainless steel, #10 bugle head, page 177</p>	2½", 3"	2½", 3"
 <p>Trim-Head Decking Screw: Sharp Point</p> <p>Type 305 stainless steel, #8 trim head, page 176</p>	2", 2½", 3"	2", 2½", 3"
 <p>Trim-Head Decking Screw: Type-17 Point</p> <p>Trim head, Quik Guard coating, page 176</p>	2", 2½", 3"	2", 2½", 3"

These coated fasteners possess a level of corrosion resistance that makes them suitable for use in some exterior and corrosive environments and with some preservative-treated woods. For applications in higher-exposure applications, consider Type-300 series stainless-steel fasteners for superior corrosion resistance. See page 15 for additional important information before selecting a fastener for a specific application.

For information on corrosion, materials and coatings, see page 15.

Drywall Applications

Quik Drive Systems Applications



Quik Drive® auto-feed screw driving systems are ideal for fastening drywall because they provide a fast, efficient solution with a precision countersink adjustment that produces consistent dimples.

PRO200 System



- Compact body for reduced weight and easy handling
- Smooth nose will not mar drywall surface
- Slim profile allows driving in corners
- Details, page 238

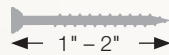

PRO250DW Attachment





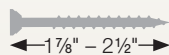







- Compact body for reduced weight and easy handling
- Smooth nose will not mar drywall surface
- Slim profile allows driving in corners
- Details, page 250

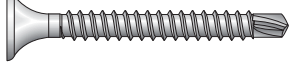

Drywall Applications (cont.)

Collated Screws for the Quik Drive® System

FASTENER MODEL	PRO200	PRO250DW
<p>DWHL Drywall Screw</p>  <p>High-low threads, gray-phosphate coating, page 191</p>	1 7/8"	1 7/8"
<p>DWC Drywall Screw</p>  <p>Drywall to wood, gray-phosphate and yellow-zinc coatings available, page 190</p>	1", 1 1/4", 1 5/8", 2"	2", 2 1/2"
<p> DWC Drywall Screw</p>  <p>Drywall to wood, N2000® galvanized coating, page 190</p>	1 1/4", 1 5/8"	N/A
<p>DWF Drywall-to-Steel Screw</p>  <p>Drywall to steel, gray-phosphate coating (33, 27, 18 mils/20, 22, 25 ga), page 200</p>	1 1/4", 1 5/8"	N/A
<p> DWFSD Drywall-to-Steel Screw</p>  <p>Drywall to steel, #2 point, yellow-zinc coating (54, 43 mils/16, 18 ga), page 200</p>	1 1/4", 1 5/8"	1 7/8", 2 3/8"
<p> DWFSD Drywall-to-Steel Screw</p>  <p>Drywall to steel, #2 point, N2000® galvanized coating (54, 43 mils/16, 18 ga), page 200</p>	1 1/4"	1 1/4"

 These coated fasteners possess a level of corrosion resistance that makes them suitable for use in some exterior and corrosive environments and with some preservative-treated woods. For applications in higher-exposure applications, consider Type-300 series stainless-steel fasteners for superior corrosion resistance. See page 15 for additional important information before selecting a fastener for a specific application.

For information on corrosion, materials and coatings, see page 15.

Fiberglass-Mat Gypsum Sheathing Applications

Quik Drive Systems Applications



Quik Drive® auto-feed screw driving systems provide a time-saving fastening method combined with the holding power of screws. Screw threads create a secure, vibration-resistant connection that prevents sheathing from shaking loose while traveling from the panel yard to the jobsite.

PRO200 System





- Compact body for reduced weight and easy handling
- Slim profile allows driving in corners
- Details, page 238

Swivel Adaptor (sold separately)

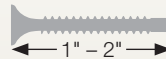
- Rotates 360° without having to detach the tool from motor
- Allows the use of one hand to rotate tool
- Easily rotate screws out of the way for corner applications



Collated Screws for the Quik Drive® System

FASTENER MODEL	PRO200
 DWFS Drywall-to-Steel Screw Yellow-zinc coating, page 200	1¼", 1⅝", 1⅞"
 DWFS Drywall-to-Steel Screw N2000® galvanized coating, page 200	1¼"
 DWC Collated Drywall Screw N2000® galvanized coating, page 190	1¼", 1⅝"

These coated fasteners possess a level of corrosion resistance that makes them suitable for use in some exterior and corrosive environments and with some preservative-treated woods. For applications in higher-exposure applications, consider Type-300 series stainless-steel fasteners for superior corrosion resistance. See page 15 for additional important information before selecting a fastener for a specific application.

For information on corrosion, materials and coatings, see page 15.

Fiber-Cement Siding Applications



Quik Drive® auto-feed screw driving systems save time when installing siding because they enable fast, efficient fastening along with a countersink adjustment to ensure consistent results.

PRO250 System



- Uniform toenailing and countersink on slick surfaces
- Non-skid nose increases stability
- Long-lasting reliability for a wide variety of applications
- Details, page 239

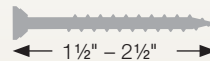

PROCGB Combo System



- Includes both PROLDH Attachment and PRO200S Attachment for added versatility
- Uniform toenailing and countersink on slick surfaces
- Non-skid nose increases stability
- Long-lasting reliability for a wide variety of applications
- Details, page 259

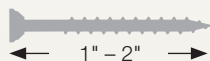

Fiber-Cement Siding Applications (cont.)

PROLDH System



- Slim profile allows driving in corners
- Drives fasteners that meet ANSI standards
- Compact body for reduced weight and easy handling
- Details, page 244

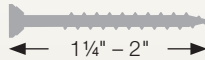

Collated Screws for the Quik Drive® System

Quik Drive Systems Applications

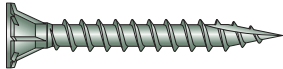
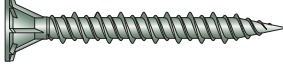
FASTENER MODEL	PRO200S	PROCGB	PROLDH	PRO300S
<p>■ CBSDQ Sheathing Screw*</p>  <p>Self-Drilling Screw* #2 drill point, Quik Guard® coating, page 199</p>	1 5/8"	1 5/8"	—	2 1/4"
<p>■ CB3BLG Fiber-Cement Board Screw</p>  <p>Type-17 point, C-3 galvanized coating, page 177</p>	—	1 1/4", 1 5/8"	1 1/4", 1 5/8"	—
<p>■ CB3BLGHL Cement Board Screw</p>  <p>High-low thread, C-3 galvanized coating, page 178</p>	—	1 1/4", 1 5/8"	1 1/4", 1 5/8"	—

* #2 Drill Point with Wings

Wings cut a path, protecting the integrity of the threads and break away before penetrating the steel.

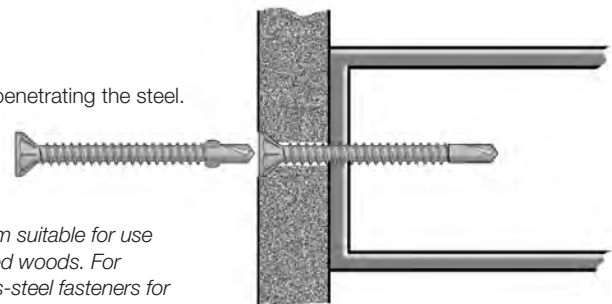

■ These coated fasteners possess a level of corrosion resistance that makes them suitable for use in some exterior and corrosive environments and with some preservative-treated woods. For applications in higher-exposure applications, consider Type-300 series stainless-steel fasteners for superior corrosion resistance. See page 15 for additional important information before selecting a fastener for a specific application.

For information on corrosion, materials and coatings, see page 15.

Standing-Seam Metal Roofing Applications



The Quik Drive® PROPP150 auto-feed screw driving system is ideal for standing-seam metal roofing because the Precision Placement™ nosepiece cuts installation time and the collated fasteners eliminate handling of individual screws.





PROPP150 System

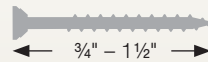

- Innovative Precision Placement nosepiece allows for easy location of the hole in the clip
- Hands-free screw advancement speeds installation
- Collated fastener strips reduce waste and prevent damage to roof panels
- Suitable for panel clips up to 2½" tall
- Also ideal for fastening panel flanges for snap-and-seam metal roofing and installing trim and drip edge
- Details, page 248

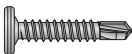

Collated Screws for the Quik Drive® System

FASTENER MODEL	PROPP150
<p>■ PC Standing-Seam-Roofing Panel Clip Screw</p>  <p>Type-17 point, Type 410 stainless steel, Quik Guard® and clear-zinc coating, page 182</p>	1", 1½"
<p>■ PCULP Standing-Seam-Roofing Panel Clip Screw</p>  <p>Type-17 point, Type 410 stainless steel, Quik Guard® and clear-zinc coating, page 183</p>	1", 1½"
<p>■ PCSD Standing-Seam Roofing Panel Clip Screw</p>  <p>#3 drill point, Type 410 stainless steel, Quik Guard® and clear-zinc coating, page 198</p>	1"
<p>■ Self-Drilling X Metal Screw</p>  <p>⅝" hex head, Quik Guard® and clear-zinc coating, page 197</p>	1"

■ *These coated fasteners possess a level of corrosion resistance that makes them suitable for use in some exterior and corrosive environments and with some preservative-treated woods. For applications in higher-exposure applications, consider Type-300 series stainless-steel fasteners for superior corrosion resistance. See page 15 for additional important information before selecting a fastener for a specific application.*

For information on corrosion, materials and coatings, see page 15.

Exposed-Fastener Metal Roofing/Siding Applications



The Quik Drive® BGP300 and PROHX14 auto-feed screw driving systems are ideal for metal roofing and siding because they speed the installation of washered screws while providing consistent results.

BGP300 System



- Patented collation belt enables auto-feed fastening of screws with EPDM-backed washers
- The extension enables stand-up fastening on low-pitch roofs
- Depth control prevents over-driving
- Designed to eliminate skipped screws, reducing screw waste
- Easy loading keeps work moving
- Screws available in 10 colors to match popular roofing-panel colors
- Details, page 237





PROHX14 System

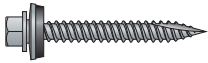

- Patented strip collation enables auto-feed fastening of screws with EPDM-backed washers
- The extension enables stand-up fastening on low-pitch roofs
- Depth control prevents over-driving
- Designed to eliminate skipped screws, reducing screw waste
- Easy loading keeps work moving
- Screws available in 10 colors to match popular roofing-panel colors
- Details, page 243

Exposed-Fastener Metal Roofing/Siding Applications

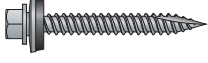
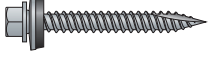
Collated Screws for the Quik Drive® System

FASTENER MODEL	BGP300	PROHX14
 HJ Metal Roofing/Siding Panel Screw ¼" Hex head, sharp point, painted, page 180 	1½"	—
 HG Metal Roofing/Siding Panel Screw ¼" Hex head, Type-17 point, Mechanically Galvanized-Class 55, page 180	1½"	1½"
 Painted HG Metal Roofing/Siding Panel Screw ¼" Hex head, Type-17 point, painted, page 180 	—	1½"

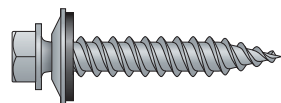

EPDM-backed washers are preassembled on the screw, ready to drive

These coated fasteners possess a level of corrosion resistance that makes them suitable for use in some exterior and corrosive environments and with some preservative-treated woods. For applications in higher-exposure applications, consider Type-300 series stainless-steel fasteners for superior corrosion resistance. See page 15 for additional important information before selecting a fastener for a specific application.

For information on corrosion, materials and coatings, see page 15.

Tile Roofing Applications



Quik Drive® auto-feed screw driving systems are a time-saving solution for tile roofing because the collated fastening strips eliminate the handling of individual screws and the attachments are designed for easy location of the holes in the tiles.

Quik Drive Systems Applications

PRORF System



- Secure depth settings prevent tile breakage
- Window in guide tube allows exact screw placement
- Long-lasting reliability for tile roofing applications
- Details, page 245

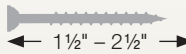

PRO300SRF System



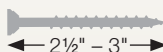

- Secure depth settings prevent tile breakage
- Window in guide tube allows exact screw placement
- Long-lasting reliability for tile roofing applications
- Details, page 246



Tile Roofing Applications (cont.)

Collated Screws for the Quik Drive® System

FASTENER MODEL	PRORF	PR0300SRF
<p>■ WSCD Roofing Tile Screw</p>  <p>Miami-Dade compliant, meets ASTM B695, class 55 galvanized coating, page 185</p>	2½"	2½", 3"
<p>WSCT Roofing Tile Screw</p>  <p>Meets ASTM A641 class 1 standard, heavy-zinc electroplate coating, page 185</p>	2½"	2½"
<p>■ SSWSCB Roofing Tile Screw</p>  <p>SSWSCB Screw Miami-Dade compliant, Type 305 stainless steel, page 184</p>	2", 2½"	2½"

■ These coated fasteners possess a level of corrosion resistance that makes them suitable for use in some exterior and corrosive environments and with some preservative-treated woods. For applications in higher-exposure applications, consider Type-300 series stainless-steel fasteners for superior corrosion resistance. See page 15 for additional important information before selecting a fastener for a specific application.

For information on corrosion, materials and coatings, see page 15.

Steel Framing/Stitching Applications



Quik Drive® auto-feed screw driving systems save time when fastening cold-formed steel framing because the collated fastening strips eliminate the handling of individual screws and the attachments hold the screw in place while it drills through the material.

Quik Drive Systems Applications

PROPH Attachment



- Compact body for reduced weight and easy handling
- Slim profile allows driving in corners
- Long-lasting reliability for targeted applications
- Details, page 254

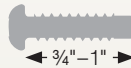

PROHX516 Attachment



- Engineered to drive screws for steel fastening
- Precise depth adjustment prevents over and under driving
- Long-lasting reliability for targeted applications
- Details, page 253



Steel Framing/Stitching Applications (cont.)

Collated Screws for the Quik Drive® System

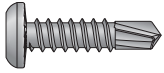
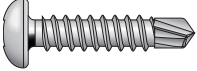
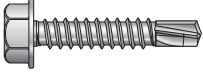
FASTENER MODEL	PROPH	PROHX516
<p>Strong-Drive® FPHSD FRAMING-TO-CFS Screw</p>  <p>Flat pan head, #3 drill point, clear-zinc coating, page 195</p>	3/4"	—
<p>Strong-Drive® PHSD FRAMING-TO-CFS Screw</p>  <p>Pan head, #2 drill point, clear-zinc coating, page 195</p>	3/4"	—
<p>Self-Drilling X Metal Screw</p>  <p>5/16" hex head, clear-zinc coating, page 197</p>	—	7/8" - 1"

Steel Decking/Stitching Applications

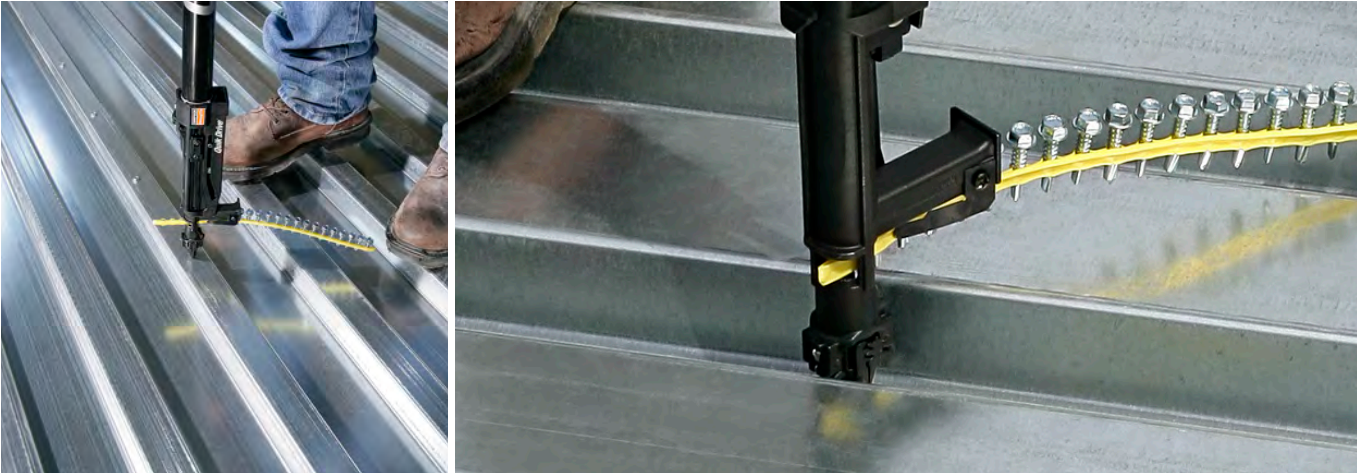

The Quik Drive® PROSD150 auto-feed screw driving system is the right choice for steel decking because it provides an efficient fastening solution that is safer and easier than welding or P.A.T.

Quik Drive Systems Applications

PROSD150 System



- Features an extended nosepiece for easy access to valley
- Stand-up driving increases comfort and productivity
- One system for fastening steel decking to structural members and steel stitching
- No special inspection or certification required as with welding or P.A.T. fastening
- Details, page 247

Steel Decking/Stitching Applications

Collated Screws for the Quik Drive™ System

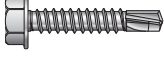
FASTENER MODEL	PROSD150
<p>Self-Drilling X Metal Screw</p>  <p>Quik Guard® coating, 5/16" hex head, page 197</p>	<p>7/8", 1", 1 1/4", 1 1/2"</p>
<p>Self-Drilling X Metal Screw</p>  <p>Clear-zinc coating, 5/16" hex head, page 197</p>	<p>3/4", 1", 1 1/4"</p>

Underlayment/Backerboard Applications



Quik Drive® auto-feed screw driving systems are ideal for underlayment because the variety of screws solves challenges such as driving over radiant heat panels and the extension enables stand-up-and-drive installation.

PROCGB Combo System



- Slim profile allows driving in corners
- Drives fasteners that meet ANSI standards
- Compact body for reduced weight and easy handling
- Includes both PROLDH Attachment and PRO200S Attachment for added versatility
- Details, page 259

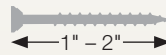

PROLDH System



- Slim profile allows driving in corners
- Compact body for reduced weight and easy handling
- Details, page 244

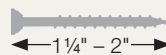

Underlayment/Backerboard Applications (cont.)





PRO200S Attachment

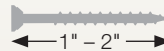

- Slim profile allows driving in corners
- Compact body for reduced weight and easy handling
- Details, page 249

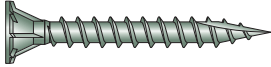
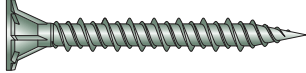

Collated Screws for the Quik Drive® System

FASTENER MODEL	PROCGB	PROLDH	PRO200S
<p>■ CB3BLG Fiber-Cement Board Screw</p>  <p>Dense cement board, C-3 mechanically-galvanized coating, meets ANSI standards, page 177</p>	1¼", 1½"	1¼", 1½"	—
<p>■ CB3BLGHL Cement Board Screw</p>  <p>Cement board to wood (for coarse, porous, and softer materials), C-3 mechanically-galvanized coating, page 178</p>	1¼", 1½"	1¼", 1½"	—
<p>DWF Drywall-TO-CFS Screw</p>  <p>Gypsum panel to steel, gray-phosphate coating, page 200</p>	1¼", 1½"	—	1¼", 1½"
<p>■ DWFSD Drywall-TO-CFS Screw</p>  <p>Gypsum panel to steel, yellow-zinc or N2000 galvanized coating, page 200</p>	1¼", 1½"	—	1¼", 1½"
<p>MTH Wood Underlayment Screw</p>  <p>Underlayment to wood, yellow-zinc and gray-phosphate coating, page 191</p>	1", 1¼"	—	1", 1¼"
<p>DWC Drywall Screw</p>  <p>Gypsum panel to wood, gray-phosphate, yellow-zinc or N2000® galvanized coating, page 190</p>	1¼", 1½", 2"	—	1¼", 1½", 2"

■ These coated fasteners possess a level of corrosion resistance that makes them suitable for use in some exterior and corrosive environments and with some preservative-treated woods. For applications in higher-exposure applications, consider Type-300 series stainless-steel fasteners for superior corrosion resistance. See page 15 for additional important information before selecting a fastener for a specific application.

For information on corrosion, materials and coatings, see page 15.

Truck Beds/Trailer Flooring Applications



Quik Drive® PROHSD auto-feed fastening systems are a time-saving solution for truck and trailer manufacturing because the extension enables stand-up driving and our self-drilling screws eliminate the need to pre-drill.

Quik Drive Systems Applications

PROHSD60 System



- Specifically engineered for trailer construction
- Expanded depth settings for various material thickness
- Broad nose increases stability and protects surfaces
- Details, page 241

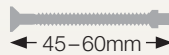

PROHSD75 System







- Specifically engineered for trailer construction
- Expanded depth settings for various material thickness
- Broad nose increases stability, protects surfaces
- Details, page 242



Truck Beds/Trailer Flooring Applications (cont.)

Collated Screws for the Quik Drive® System

FASTENER MODEL	PROHSD60	PROHSD75
Strong-Drive® TB WOOD-TO-STEEL Screw  #4 drill point, black-phosphate coating, page 194	45, 60mm	60, 75mm
 Strong-Drive® TB WOOD-TO-STEEL Screw #4 drill point, N2000® galvanized coating, page 194	45, 60mm	60, 75mm
Strong-Drive® TB WOOD-TO-STEEL Screw  #4 drill point, yellow-zinc coating, page 194	45, 60mm	60, 75mm
Strong-Drive® PPSD SHEATHING-TO-CFS Screw  #3 drill, yellow-zinc coating, page 196	1¾"	3"
 Strong-Drive® PPSD SHEATHING-TO-CFS Screw #3 drill point, Quik Guard® coating, page 196	1¾"	3"

■ These coated fasteners possess a level of corrosion resistance that makes them suitable for use in some exterior and corrosive environments and with some preservative-treated woods. For applications in higher-exposure applications, consider Type-300 series stainless-steel fasteners for superior corrosion resistance. See page 15 for additional important information before selecting a fastener for a specific application.

For information on corrosion, materials and coatings, see page 15.

Crating Applications



Quik Drive® auto-feed screw driving systems save time when building crates because they enable accurate screw placement and hands-free fastener advancement.

Quik Drive Systems Applications

PRO250 System



- Expanded depth settings for appropriate countersink in a variety of applications
- Uniform toenailing and countersink on slick surfaces
- Reversible and replaceable non-skid teeth attachment
- Details, page 239

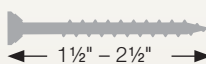

PRO300S System





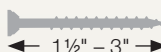

- Expanded depth settings for appropriate countersink in a variety of applications
- Reversible and replaceable non-skid teeth attachment
- Uniform toenailing and countersink on slick surfaces
- Sure-grip guide tube increases stability for a broad range of screws
- Details, page 240



Crating Applications (cont.)

Collated Screws for the Quik Drive® System

FASTENER MODEL	PR0250	PR0300S	PR0200S
Strong-Drive® WSNTL WOOD Screw  Twin thread, twin thread, pages 188-189	1¾", 2", 2½"	1¾", 2", 2½", 3"	—
WSHL Wood Screw  High-low threads, gray-phosphate coating, page 190	1¾"	1¾"	—
PHSS Wood Screw  Sharp point, yellow-zinc coating, page 193	2", 2½"	2", 2½"	—
DWC Drywall Screw  Drywall to wood, gray-phosphate, N2000® and yellow-zinc coatings available, page 190	—	—	1¼", 1⅝"

Truss-Ply Fastening Applications



Quik Drive® auto-feed screw driving systems are ideal for truss-ply fastening because the extension enables stand-up-and-drive installation and the holding power of screws can reduce the gapping between plies, improving the quality of the girder.

Quik Drive Systems Applications

PRO250 System



- Expanded depth settings for high-density flooring materials
- Uniform toenailing and countersink on slick surfaces
- Reversible and replaceable non-skid teeth attachment
- Details, page 239

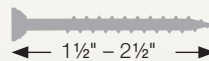

PRO300S System



- Expanded depth settings for appropriate countersink in a variety of applications
- Reversible and replaceable non-skid teeth attachment
- Sure-grip guide tube increases stability for a broad range of screws
- Details, page 240

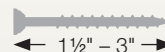

Truss-Ply Fastening Applications (cont.)

PROCCS+ Combo System



- Expanded depth settings for appropriate countersink in a variety of applications
- Reversible and replaceable non-skid teeth attachment
- Includes both PRO300S Attachment and PRO200S Attachment for added versatility
- Sure-grip guide tube increases stability for a broad range of screws
- Details, page 258

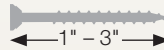

Collated Screws for the Quik Drive® System

FASTENER MODEL	PRO250	PRO300s/CCS+
Strong-Drive® WSNTL WOOD Screw  Twin thread, twin thread, pages 188-189	2½"	2½", 3"

Nailers/Ledgers-to-Steel Applications



Quik Drive® PROHSD auto-feed fastening systems are ideal for wood-to-steel fastening because they hold the screw in place while drilling and our self-drilling screws eliminate the need for pre-drilling.

Quik Drive Systems Applications

PROHSD60 System



- Specifically engineered for fastening wood-to-steel
- Expanded depth settings for various material thickness
- Broad nose increases stability and protects surfaces
- Details, page 241

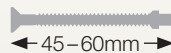

PROHSD75 System





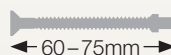

- Specifically engineered for fastening wood-to-steel
- Expanded depth settings for various material thickness
- Broad nose increases stability and protects surfaces
- Details, page 242



Nailers/Ledgers-to-Steel Applications

Collated Screws for the Quik Drive® System

FASTENER MODEL	PROHSD60	PROHSD75
Strong-Drive® TB WOOD-TO-STEEL Screw  Black-phosphate coating, page 194	45, 60mm	60, 75mm
Strong-Drive® TB WOOD-TO-STEEL Screw  Yellow-zinc coating, page 194	45, 60mm	60, 75mm
 Strong-Drive® TB WOOD-TO-STEEL Screw N2000® galvanized coating, page 194	45, 60mm	60, 75mm
 Strong-Drive® PPSD SHEATHING-TO-CFS Screw Quik Guard® coating, page 196	1¾"	1¾", 3"
 Strong-Drive® PPSD SHEATHING-TO-CFS Screw Yellow-zinc coating, page 196	1¾"	1¾", 3"

■ These coated fasteners possess a level of corrosion resistance that makes them suitable for use in some exterior and corrosive environments and with some preservative-treated woods. For applications in higher-exposure applications, consider Type-300 series stainless-steel fasteners for superior corrosion resistance. See page 15 for additional important information before selecting a fastener for a specific application.

For information on corrosion, materials and coatings, see page 15.

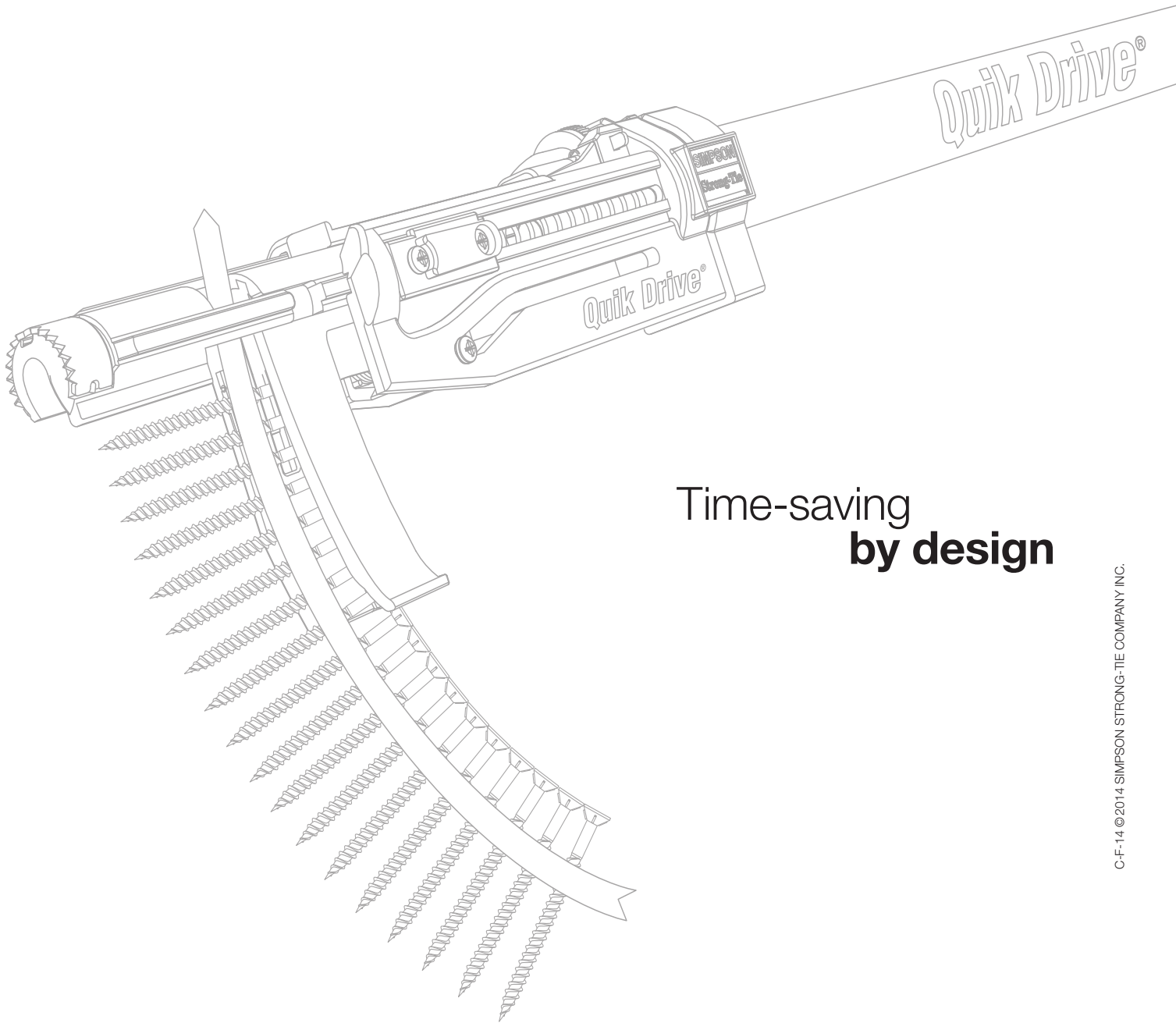

Time-saving
by design

Quik Drive® Systems

SIMPSON
Strong-Tie



Quik Drive® – Auto-Feed Screw Driving Systems

Quik Drive® Systems



PRO200 Drywall System

Applications: Drywall to wood or steel
(See page 238 for more information)



PRO250 Subfloor System

Applications: Subflooring-to-wood or steel, decks and docks, fiber-cement siding-to-steel (See page 239 for more information)



PRO300S Decking System

Applications: Decks and docks, subflooring-to-wood or steel, wall plates, stair treads, sheathing, fiber-cement siding to steel. (See page 240 for more information)



PRO300SRF Roofing Tile System

Applications: Roofing tiles to wood
(See page 246 for more information)



PRORF Roofing Tile System

Applications: Roofing tiles to wood
(See page 245 for more information)



PROHSD60 Wood-to-Steel System

Applications: Truck beds and trailer flooring to steel, wood nailers to structural steel (See page 241 for more information)



PROHSD75 Wood-to-Steel System

Applications: Truck beds and trailer flooring to steel, wood nailers to structural steel (See page 242 for more information)



PROHX14 Metal Roofing/Siding System

Applications: Exposed fastener metal roofing to wood, metal siding to wood (See page 243 for more information)



BGP300 Metal Roofing/Siding System

Applications Exposed-fastener metal roofing to wood, metal siding to wood (See page 237 for more information)



PROLDH Underlayment/Backerboard System

Applications: Cement board and fiber-cement board underlayment/backerboard to wood or steel (See page 244 for more information)



PROSD150 Steel-Decking System

Applications: Metal-roofing clips, steel decking/stitching
(See page 247 for more information)



PROPP150 Metal Roofing System

Applications: Panel clips for standing-seam roofing, steel decking to structural steel members, panel flanges for snap-and-seam metal roofing (See page 248 for more information)

Quik Drive® – Auto-Feed Screw Driving Systems

Quik Drive® Combo Systems



PROSDD Multi-Purpose Combo System

PRO300 Attachment Applications: Subfloor to wood or steel, wall plates, stair treads, sheathing, decking on decks and docks.
PRO200 Attachment Applications: Drywall to wood or steel
(See page 257 for more information)



PROCCS+ Multi-Purpose Combo System

PRO300S and PRO200S Attachment Applications: Subfloor to wood or steel, wall plates, stair treads, sheathing, decking on decks and docks, fiber-cement siding to steel (See page 258 for more information)



PROCGB Underlayment/Backerboard Combo System

PROLDH and PRO200S Attachment Applications: Cement board and fiber-cement board underlayment to wood or steel, backerboard to wood or steel, gypsum panel to wood or steel (See page 259 for more information)

Quik Drive® Attachments



PRO200 Drywall Attachment

Applications: Drywall to wood or steel (See page 249 for more information)



PRO200S Multi-Purpose Attachment

Applications: Subfloor to wood or steel, wall plates, stair treads, sheathing, fiber-cement siding to steel, gypsum panel to wood or steel (See page 249 for more information)



PRO250 Subfloor Attachment

Applications: Subfloor to wood or steel
(See page 250 for more information)



PRO250DW Drywall Attachment

Applications: Fasten drywall to wood or steel
(See page 250 for more information)



PRO300S Decking Attachment

Applications: Decking on decks and docks, subfloor to wood or steel, wall plates, stair treads, sheathing, fibercement siding to steel
(See page 251 for more information)

Quik Drive® – Auto-Feed Screw Driving Systems

Quik Drive® Attachments (cont.)

PROHSD60 Wood-to-Steel Fastening Attachment

Applications: Truck beds and trailer flooring to steel, wood nailers to structural steel (See page 252 for more information)

PROHSD75 Wood-to-Steel Fastening Attachment

Applications: Truck beds and trailer flooring to steel, wood nailers to structural steel (See page 252 for more information)

PROHX14 Metal Roofing/Siding Attachment

Applications: Metal roofing to wood (See page 253 for more information)

PROHX516 Steel-to-Steel Fastening Attachment

Applications: Cold-formed steel framing, steel decking to structural steel members (See page 253 for more information)

PROLDH Underlayment/Backerboard Attachment

Applications: Cement board and fiber-cement board underlayment/backerboard to wood or steel (See page 254 for more information)

PROPH Cold-Formed Steel Framing Attachment

Applications: Fasten cold-formed steel framing (See page 254 for more information)

PROPP150 Metal Roofing Attachment

Applications: Panel clips for standing-seam roofing, steel decking to structural steel members, panel flanges for snap-and-seam metal roofing (See page 256 for more information)

PRO300SRF Roofing Tile Attachment

Applications: Roofing tiles to wood (See page 255 for more information)

PRORF Roofing Tile Attachment

Applications: Roofing tiles to wood (See page 255 for more information)

PROSD150 Steel-Decking Attachment

Applications: Steel decking to structural steel members (See page 256 for more information)

BGP300 Metal-Roofing/Siding System



The locking depth control seats the washer on the fastener and helps prevent overdriving that can damage metal roofing and siding.

The profile guides match the panel-ridge profiles with "feet" that rest on the flat portion of the panel. This centers the screw on the ridge for a uniform look and a better fastener seal.

Applications: Exposed-fastener metal-roofing to wood, metal siding to wood

- Patented belt collation enables auto-feed fastening of screws with EPDM-backed washers (U.S. Patent 6,783,001)
- Profile guide on nosepiece ensures uniform screw placement
- The extension enables stand-up fastening on roofs
- Depth control prevents over-driving
- Designed to eliminate skipped screws, reducing screw waste (patent pending)

Limited lifetime warranty on attachment and extension, 1-year limited warranty on screw-driver motors (see specific manufacturer's warranty for more information)



The BGP300 system includes:

- BGP300 Metal-Roofing/Siding Attachment
- 2 profile guides (flat and AG Panel)
- 2 lobular hex-head driver bits (1/4" and 5/16")
- 16" extension
- Belt hook fastener-strip holder
- Rugged tool box

The BGP300 does not include a screwdriver motor.

BGP300 System

Drive These Collated Screws WITH EPDM-BACKED WASHERS

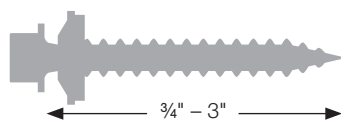

HJ Metal Roofing/Siding Panel Screw	page 180
HG Metal Roofing/Siding Panel Screw	page 180

System	Model No.
Attachment, 16" extension, (1) flat profile guide, (1) AG panel / 3/4" rib profile guide	QDBGP300G2K
Parts	Model No.
Replacement attachment mandrel with 1/4" hex bit	BPHXLBGP14G2
Replacement attachment mandrel with 5/16" hex bit	BPHXLBGP516G2

1. For more information on screwdriver motors and RPM recommendations per application, see pages 260-262

PRO200 Drywall System



Applications: Drywall to wood or steel

- Compact body for reduced weight and easy handling
- Slim profile allows driving in corners
- Smooth nose will not mar drywall surface
- The patented curved collation strips (U.S. Patent 7,051,875) hold the screws up and away from the work surface, making moving and positioning the tool easier. They are also pointed on the inserted end to simplify loading

Limited lifetime warranty on attachment and extension, 1-year limited warranty on screw-driver motors (see specific manufacturer's warranty for more information)



The PRO200 System includes:

- PRO200 Drywall Attachment (also sold separately)
- Extension
- Screwdriver motor
- Screw quiver
- Rugged toolbox

For longer drywall screws (1 7/8" – 2 1/4") see the PRO250DW attachment on page 250

Quik Drive® Systems

PRO200 System

Drive These Collated Screws

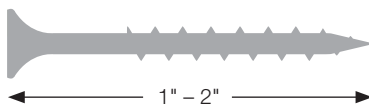

DWC Drywall Screw	page 190
DWHL Drywall Screw	page 191
DWF Drywall-to-CFS Screw	page 200
DWFSD Drywall-to-CFS Screw	page 200

System Options	Model No.
DeWalt® 2500 rpm screwdriver motor	PRO200G2D25K
Makita® 2500 rpm screwdriver motor	PRO200G2M25K
Parts	
Attachment only	QDPRO200G2
Replacement attachment mandrel	PMANDREL65

For more information on screwdriver motors and RPM recommendations per application, see pages 260-262

PRO250 Subfloor System



Applications: Subfloor to wood or steel

- Expanded depth settings for appropriate countersink in a variety of applications
- Reversible replaceable non-skid teeth attachment
- Uniform toenailing and countersink on slick surfaces
- The patented curved collation strips (U.S. Patent 7,051,875) hold the screws up and away from the work surface, making moving and positioning the tool easier. They are also pointed on the inserted end to simplify loading

Limited lifetime warranty on attachment and extension, 1-year limited warranty on screw-driver motors (see specific manufacturer's warranty for more information)



The PRO250 System includes:

- PRO250 Subfloor Attachment (also sold separately)
- Extension
- Screwdriver motor
- Screw quiver
- Rugged toolbox

PRO250 System

Quik Drive® Systems

C-F-14 ©2014 SIMPSON STRONG-TIE COMPANY INC.

Drive These Collated Screws			
Strong-Drive® WSNTL Subfloor Screw	page 188	WSC Wood Screw	page 193
Strong-Drive® PPSD Sheathing-to-CFS Screw	page 196	PHSS Wood Screw	page 193
Deck-Drive™ DSV Wood Screw	page 174	Trim-Head Decking Screw: Type-17 Point	page 176
Deck-Drive™ DCSD Composite-to-Steel Screw	page 187	Composi-Lok™ Composite-Decking Screw	page 186
WSHL Subfloor Screw	page 190	DWC Drywall Screw	page 190
CBSDQ Sheathing-to-CFS Screw	page 199	DWFSD Drywall-to-CFS Screw	page 200
WSFLRV Wood-to-CFS/Aluminum Screw	page 201		

System Options	Model No.
DeWalt® 2500 rpm screwdriver motor	PRO250G2D25K
Makita® 2500 rpm screwdriver motor	PRO250G2M25K
Makita® 3500 rpm screwdriver motor	PRO250G2M35K
Milwaukee® 2500 rpm screwdrive motor	PRO250MW25K
Milwaukee® 4000 rpm screwdrive motor	PRO250MW40K
Parts	
Attachment only	QDPRO250G2
Replacement attachment mandrel	PMANDREL75

• For more information on screwdriver motors and RPM recommendations per application, see pages 260-262

PRO300S Decking System



Applications: Decking on decks and docks, subfloor to wood or steel, wall plates, stair treads, sheathing, fiber-cement siding to steel

- Expanded depth settings for high-density flooring materials
- Reversible and replaceable non-skid teeth
- Uniform toenailing and countersink on slick surfaces
- Sure-grip guide tube increases stability for a broad range of screws
- The patented curved collation strips (U.S. Patent 7,051,875) hold the screws up and away from the work surface, making moving and positioning the tool easier. They are also pointed on the inserted end to simplify loading

Limited lifetime warranty on attachment and extension, 1-year limited warranty on screw-driver motors (see specific manufacturer's warranty for more information)



The PRO300S System includes:

- PRO300S Decking Attachment (also sold separately)
- Extension
- Screwdriver motor
- Screw quiver
- Rugged toolbox
- Decking nose clip

The decking nose clip positions the screw on the deck board and centers it on the joist for an easy, uniform installation from a standing position.

PRO300S System

Drive These Collated Screws



Deck-Drive™ DSV Wood Screw	page 174
Deck-Drive™ DWP Wood SS Screw	page 174
Deck-Drive™ DHPD Hardwood Screw	page 175
Strong Drive® WSNTL Wood Screw	page 175
Composi-Lok™ Composite-Decking Screw	page 186
Trim-Head Decking Screw: Type-17 Point	page 176
Trim-Head Decking Screw: Sharp Point	page 176
SS3DSC Bugle-Head Wood Decking Screw	page 177
CBSDQ Sheathing-to-CFS Screw	page 199

System Options	Model No.
DeWalt® 2500 rpm screwdriver motor	PRO300SD25K
Makita® 2500 rpm screwdriver motor	PRO300SM25K
Makita® 3500 rpm screwdriver motor	PRO300SM35K
Milwaukee® 2500 rpm screwdriver motor	PRO300SMW25K
Milwaukee® 4000 rpm screwdriver motor	PRO300SMW40K
Parts	
Attachment only	QDPRO300SG2
Replacement attachment mandrel	PMANDREL75

For more information on screwdriver motors and RPM recommendations per application, see pages 260-262

PROHSD60 Wood-to-Steel System



Applications: Truck beds and trailer flooring to steel, wood nailers to structural steel

- Slim profile allows driving in corners
- Compact body for reduced weight and easy handling

Limited lifetime warranty on attachment and extension, 1-year limited warranty on screw-driver motors (see specific manufacturer's warranty for more information)



The PROHSD60 System includes:

- PROHSD60 Wood-to-Steel Attachment (also sold separately)
- Extension
- Screwdriver motor
- Screw quiver
- Rugged toolbox

PROHSD60 System

C-F-14 ©2014 SIMPSON STRONG-TIE COMPANY INC.

Quik Drive® Systems

Drive These Collated Screws	
Strong-Drive® TB Wood-to-Steel Screw	page 194
Strong-Drive® PPSD Sheathing-to-CFS Screw	page 196

System Options	Model No.
Hitachi® 1700 rpm screwdriver motor	PROHSD60H17K
Makita® 1000–2000 rpm screwdriver motor	PROHSD60MVK
Makita® 2500 rpm screwdriver motor	PROHSD60M25K
Parts	Model No.
Attachment only	QDHS60
Replacement attachment mandrel	PMANDREL75

For more information on screwdriver motors and RPM recommendations per application, see pages 260-262.

For applications where maximum torque is preferred, see the Hitachi® screwdriver motor HIW8VB2 on page 261 (sold separately).

PROHSD75 Wood-to-Steel System



Applications: Truck beds and trailer flooring to steel, wood nailers to structural steel

- Slim profile allows driving in corners
- Compact body for reduced weight and easy handling

Limited lifetime warranty on attachment and extension, 1-year limited warranty on screw-driver motors (see specific manufacturer's warranty for more information)



The PROHSD75 System includes:

- PROHSD75 Wood-to-Steel Attachment (also sold separately)
- Extension
- Screwdriver motor
- Screw quiver
- Rugged toolbox

Quik Drive® Systems

PROHSD75 System

Drive These Collated Screws

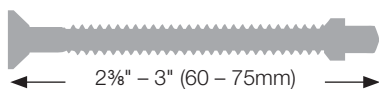

Strong-Drive® TB Wood-to-Steel Screw	page 194
Strong-Drive® PPSD Sheathing-to-CFS Screw	page 196

System Options	Model No.
Hitachi® 1700 rpm screwdriver motor	PROHSD75H17K
Makita® 1000–2000 rpm screwdriver motor	PROHSD75MVK
Parts	Model No.
Attachment only	QDHS75
Replacement attachment mandrel	PMANDREL75

For more information on screwdriver motors and RPM recommendations per application, see pages 260-262.

For applications where maximum torque is preferred, see the Hitachi® screwdriver motor HIW8VB2 on page 261 (*sold separately*).

PROHX14 Metal Roofing/Siding System



Applications: Exposed-fastener metal roofing-to-wood, metal siding-to-wood

- Precise depth adjustment prevents over and under driving
- Drives fasteners for steel-to-wood framing
- Tough reliability for targeted applications

Limited lifetime warranty on attachment and extension, 1-year limited warranty on screw-driver motors (see specific manufacturer's warranty for more information)



The PROHX14 System includes:

- PROHX14 Metal Roofing/Siding Attachment (also sold separately)
- Extension
- Screwdriver motor
- Screw quiver
- Rugged toolbox

PROHX14 System

C-F-14 ©2014 SIMPSON STRONG-TIE COMPANY INC.

Quik Drive® Systems

Drive These Collated Screws	
HG Metal Roofing/Siding Panel Screw	page 180

For more information on corrosion, see page 15.

System Options	Model No.
Makita® 2500 rpm screwdriver motor	PROHX14G2M25K
Parts	Model No.
Attachment only	QDPROHX14G2
Replacement attachment mandrel	BPHX14G2

For more information on screwdriver motors and RPM recommendations per application, see pages 260-262.

PROLDH Underlayment/Backerboard System



Applications: Cement board and fiber-cement board underlayment/backerboard to wood or steel

- Slim profile allows driving in corners
- Drives fasteners that meet ANSI standards
- Compact body for reduced weight and easy handling

Limited lifetime warranty on attachment and extension, 1-year limited warranty on screw-driver motors (see specific manufacturer's warranty for more information)



The PROLDH System includes:

- PROLDH Underlayment/Backerboard Attachment (also sold separately)
- Extension
- Screwdriver motor
- Screw quiver
- Rugged toolbox

Quik Drive® Systems

PROLDH System

Drive These Collated Screws

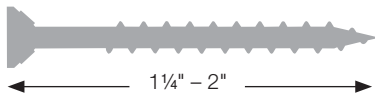

CB3BLG Fiber-Cement Board Screw

page 177

CB3BLGHL Cement Board Screw

page 178

System Options

Makita® 2500 rpm screwdriver motor

Model No.

PROLDHG2M25K

Parts

Model No.

Attachment only

QDPROLDHG2

Replacement attachment mandrel

PMANDREL65

For more information on screwdriver motors and RPM recommendations per application, see pages 260-262.

PRORF Roofing Tile System



• **Visibility window** allows precise visual placement of screws

Applications: Roofing tiles to wood

- Precision depth settings prevent tile breakage
- Window in guide tube provides visibility to allow exact screw placement
- Drives fasteners meeting code requirements

Limited lifetime warranty on attachment and extension, 1-year limited warranty on screw-driver motors (see specific manufacturer's warranty for more information)



The PRORF System includes:

- PRORF Roofing Tile Attachment (also sold separately)
- Extension
- Screwdriver motor
- Screw quiver
- Rugged toolbox

PRORF System

C-F-14 ©2014 SIMPSON STRONG-TIE COMPANY INC.

Quik Drive® Systems

Drive These Collated Screws	
WSCD Roofing Tile Screw	page 185
WSCT Roofing Tile Screw	page 185
SSWSCB Roofing Tile Screw	page 184

System Options	Model No.
Makita® 2500 rpm screwdriver motor	PRORFG2M25K
Makita® 3500 rpm screwdriver motor	PRORFG2M35K
Parts	Model No.
Attachment only	QDPRORFG2
Replacement attachment mandrel	PMANDREL75

For more information on screwdriver motors and RPM recommendations per application, see pages 260-262.

PRO300SRF Roofing-Tile System



• **Visibility window** allows precise visual placement of screws

Applications: Roofing tiles to wood

- Precision depth settings prevent tile breakage
- Window in guide tube provides visibility to allow exact screw placement
- Drives fasteners meeting code requirements
- The patented curved collation strips (U.S. Patent 7,051,875) hold the screws up and away from the work surface, making moving and positioning the tool easier. They are also pointed on the inserted end to simplify loading

Limited lifetime warranty on attachment and extension, 1-year limited warranty on screw-driver motors (see specific manufacturer's warranty for more information)



The PRO300SRF System includes:

- PRO300SRF Roofing Tile Attachment (also sold separately)
- Extension
- Screwdriver motor
- Screw quiver
- Rugged toolbox

Quik Drive® Systems

PRO300SRF System

Drive These Collated Screws

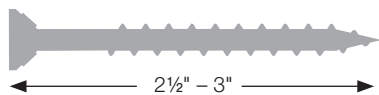

WSCD Roofing Tile Screw	page 185
WSCT Roofing Tile Screw	page 185
SSWSCB Roofing Tile Screw	page 184

System Options	Model No.
Makita® 2500 rpm screwdriver motor	PRO300SRFG2M25K
Makita® 3500 rpm screwdriver motor	PRO300SRFG2M35K
Parts	Model No.
Attachment only	QDPRO300SRFG2
Replacement attachment mandrel	PMANDREL75

For more information on screwdriver motors and RPM recommendations per application, see pages 260-262

PROSD150 Steel-Decking System



Innovative Precision Placement™
nosepiece allows for easy location

Applications: Steel decking to structural steel members

- Innovative Precision Placement™ nosepiece.
- Auto-feed mechanism provides hands-free screw advancement, eliminating handling of individual screws, cutting installation time in half

Limited lifetime warranty on attachment and extension, 1-year limited warranty on screw-driver motors (see specific manufacturer's warranty for more information)



The PROSD150 System includes:

- PROSD150 Steel-Decking Attachment (also sold separately)
- Extension
- Screwdriver motor
- Screw quiver
- Rugged toolbox

U.S. Patents 5,570,618 and 8,356,534

PROSD150 System

C-F-14 ©2014 SIMPSON STRONG-TIE COMPANY INC.

Quik Drive® Systems

Drive These Collated Screws	
Self-Drilling X Metal Screw	page 197
Strong-Drive® FPHSD Framing-to-CFS screw	page 195

System Options	Model No.
DeWalt® 2000rpm Adjustable Torque Motor	PROSD150G2DATK
Parts	Model No.
Attachment only	QDPROSD150G2
Replacement Extension	QDEXTG2-16
Replacement 16" Extension Mandrel	PMANDREXTG2-16
Replacement 5/16" Hex Bit	BITHEXLB516LG
Replacement Hex Mandrel with 5/16" Hex Bit	BPHXLBSDG2

For more information on screwdriver motors and RPM recommendations per application, see pages 260-262. System includes mandrels for driving recessed and 5/16 hex bits.

PROPP150 Metal Roofing System



Applications: Panel clips for standing-seam roofing, steel decking to structural steel members, panel flanges for snap-and-seam metal roofing

- Innovative Precision Placement™ nosepiece allows for easy location of the holes in standing seam metal roofing clips

- Auto-feed mechanism provides hands-free screw advancement, eliminating handling of individual screws, cutting installation time in half
- Screws available in 4 head styles with 2 levels of corrosion resistance

Limited lifetime warranty on attachment and extension, 1-year limited warranty on screw-driver motors (see specific manufacturer's warranty for more information)



The PROPP150 System includes:

- PROPP150 Metal Roofing Attachment (also sold separately)
- Extension
- Screwdriver motor
- Screw quiver
- Rugged toolbox

U.S. Patents 5,570,618 and 8,356,534

Quik Drive® Systems

PROPP150 System

Drive These Collated Screws	
PC Standing-Seam-Roofing Panel Clip Screw	page 182
PCSD Standing-Seam Roofing Panel Clip Screw	page 198
PCULP Standing-Seam-Roofing Panel Clip Screw	page 192
Self-Drilling X Metal Screw	page 197

System Options	Model No.
DeWalt® 2000 rpm adjustable torque screwdriver motor	PROPP150G2DATK
Makita® 2500 rpm screwdriver motor	PROPP150G2M25K
Makita® 2500 rpm adjustable-torque screwdriver motor	PROPP150G2MATK
Parts	Model No.
Attachment only	QDPROPP150G2
Replacement attachment mandrel	PMANDREL10
Replacement hex bit and mandrel	BPHXLBPPG2

For more information on screwdriver motors and RPM recommendations per application, see pages 260-262. System includes mandrels for driving recessed and 3/16 hex bits.

PRO200 Drywall Attachment



Applications: Drywall to wood or steel

Drive These Collated Screws	
DWC Drywall Screw	page 190
DWHL Drywall Screw	page 191
DWF Drywall-to-CFS Screw	page 200
DWFSD Drywall-to-CFS Screw	page 200

Parts	Model No.
Attachment only	QDPRO200G2
Replacement mandrel	PMANDREL65

Limited lifetime warranty on attachment and extension, 1-year limited warranty on screw-driver motors (see specific manufacturer's warranty for more information)

PRO200 Attachment

PRO200S Multi-Purpose Attachment



Applications: Subfloor to wood or steel, sheathing, fiber-cement siding to steel, gypsum panel to wood or steel

Drive These Collated Screws			
Strong-Drive® WSNTL Subfloor Screw	page 188	DWC Drywall Screw	page 190
Trim-Head Decking Screw: Type-17 Point	page 176	DWF Drywall-to-CFS Screw	page 200
Trim-Head Decking Screw: Sharp Point	page 176	DWFSD Drywall Screw	page 200
PHSS Wood Screw	page 193	CBSDQ Sheathing-to-CFS Screw	page 199
WSC Wood Screw	page 193	MTH Wood Underlayment Screw	page 191
FHSD Wood-to-CFS Screw	page 201		
Parts	Model No.		
Attachment Only	QDPRO200S		
Replacement mandrel	PMANDREL75		

Limited lifetime warranty on attachment and extension, 1-year limited warranty on screw-driver motors (see specific manufacturer's warranty for more information)

PRO200S Attachment

PRO250 Subfloor Attachment



Applications: Subfloor to wood or steel

Drive These Collated Screws			
Strong-Drive® WSNTL Subfloor Screw	page 188	WSC Wood Screw	page 184
Strong-Drive® PPSD Sheathing-to-CFS Screw	page 196	PHSS Wood Screw	page 193
Deck-Drive™ DSV Wood Screw	page 174	Trim-Head Decking Screw: Type-17 Point	page 176
Deck-Drive™ DCSD Composite-to-Steel Screw	page 187	Composi-Lok™ Composite-Decking Screw	page 186
WSHL Subfloor Screw	page 190	DWC Drywall Screw	page 190
CBSDQ Sheathing-to-CFS Screw	page 199	DWFSD Drywall Screw	page 200
WSFLRV Wood-to-CFS/Aluminum Screw	page 201		

Parts	Model No.
Attachment only	QDPRO250G2
Replacement mandrel	PMANDREL75

Limited lifetime warranty on attachment and extension, 1-year limited warranty on screw-driver motors (see specific manufacturer's warranty for more information)

PRO250 Attachment

PRO250DW Drywall Attachment

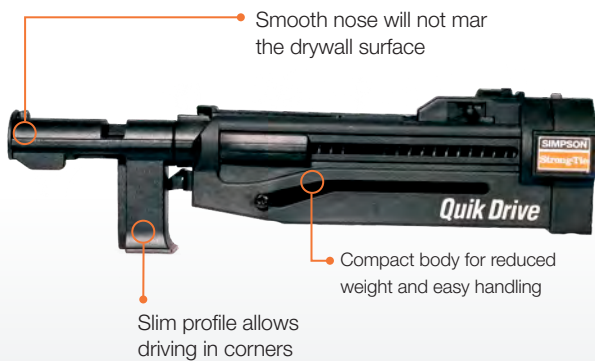

Applications: Fasten drywall to wood or steel

Drive These Collated Screws	
DWC Drywall Screw	page 190
DWHL Drywall Screw	page 191
DWFSD Drywall Screw	page 200

Parts	Model No.
Attachment Only	QDPRO250DWG2
Replacement Mandrel	PMANDREL75

Limited lifetime warranty on attachment and extension, 1-year limited warranty on screw-driver motors (see specific manufacturer's warranty for more information)

PRO250DW Attachment

PRO300S Decking Attachment



Applications: Decking on decks and docks, subfloor to wood or steel, wall plates, stair treads, sheathing, fiber-cement siding to steel

Drive These Collated Screws	
Deck-Drive™ DSV Wood Screw	page 174
Deck-Drive™ DWP Wood SS Screw	page 174
Deck-Drive™ DHPD Hardwood Screw	page 175
Strong Drive® WSNTL Wood Screw	page 175
Composi-Lok™ Composite-Decking Screw	page 186
Trim-Head Decking Screw: Type-17 Point	page 176
Trim-Head Decking Screw: Sharp Point	page 176
SS3DSC Bugle-Head Wood Decking Screw	page 177
CBSDQ Sheathing-to-CFS Screw	page 199

Parts	Model No.
Attachment only	QDPRO300SG2
Replacement mandrel	PMANDREL75

Limited lifetime warranty on attachment and extension, 1-year limited warranty on screw-driver motors (see specific manufacturer's warranty for more information)

PRO300S Attachment

PROHSD60 Wood-to-Steel Fastening Attachment



Applications: Truck beds and trailer flooring to steel, wood nailers to structural steel

Limited lifetime warranty on attachment and extension, 1-year limited warranty on screw-driver motors (see specific manufacturer's warranty for more information)

Drive These Collated Screws

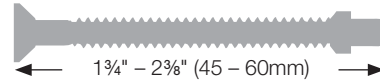

Strong-Drive® TB Wood-to-Steel Screw	page 194
--------------------------------------	----------

Strong-Drive® PPSD Sheathing-to-CFS Screw	page 196
---	----------

Parts

Model No.

Attachment only	QDHSD60
-----------------	---------

Replacement mandrel	PMANDREL75
---------------------	------------

PROHSD75 Wood-to-Steel Fastening Attachment



Applications: Truck beds and trailer flooring to steel, wood nailers to structural steel

Limited lifetime warranty on attachment and extension, 1-year limited warranty on screw-driver motors (see specific manufacturer's warranty for more information)

Drive These Collated Screws

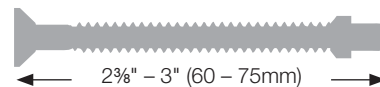

Strong-Drive® TB Wood-to-Steel Screw	page 194
--------------------------------------	----------

Strong-Drive® PPSD Sheathing-to-CFS Screw	page 196
---	----------

Parts

Model No.

Attachment only	QDHSD75
-----------------	---------

Replacement mandrel	PMANDREL75
---------------------	------------

PROHX14 Metal Roofing/Siding Attachment



Applications: Exposed-fastener metal roofing-to-wood, Metal siding-to-wood

Features:

- Strip collation enables auto-feed fastening of screws with EPDM-backed washers
- Precise depth adjustment prevents over- and under-driving
- Drives fasteners for steel-to-wood framing
- Designed to eliminate skipped screws, reducing screw waste
- Easy loading keeps work moving

Limited lifetime warranty on attachment and extension, 1-year limited warranty on screw-driver motors (see specific manufacturer's warranty for more information)

PROHX14 Attachment

Drive These Collated Screws	
HG Metal Roofing/Siding Panel Screw (galvanized and painted with washer)	page 180
HG Metal Roofing/Siding Panel Screw (galvanized without washer)	page 180

For information on Quik Drive screw coatings, see page 16. For more information on corrosion, see pages 13-15.

Parts	Model no.
Attachment Only	QDPROHX14
Replacement Mandrel	BPHXLB14G2
Replacement Bit	BITHEXLB14
Replacement Noseguard	PNOSEGUARD-5

PROHX516 Steel-to-Steel Fastening Attachment



Applications: Cold-formed steel framing, steel decking to structural steel members

Features:

- Compact body for reduced weight and easy handling
- Slim profile allows driving in corners
- Tough reliability for targeted applications

Limited lifetime warranty on attachment and extension, 1-year limited warranty on screw-driver motors (see specific manufacturer's warranty for more information)

PROHX516 Attachment

Drive These Collated Screws	
Self-Drilling X Metal Screw	page 197

Parts	Model No.
Attachment only	QDPROHX516G2
Replacement mandrel	BPHX516G2

For applications where maximum torque is preferred, see the Hitachi® screwdriver motor HIW8VB2 on page 261 (sold separately).

PROLDH Underlayment/Backerboard Attachment



Applications: Cement board and fiber-cement board underlayment/backerboard to wood or steel

Drive These Collated Screws	
CB3BLG Fiber-Cement Board Screw	page 177
CB3BLGHL Cement Board Screw	page 178

Parts	Model No.
Attachment only	QDPROLDHG2
Replacement mandrel	PMANDREL65

Limited lifetime warranty on attachment and extension, 1-year limited warranty on screw-driver motors (see specific manufacturer's warranty for more information)

PROLDH Attachment

PROPH Cold-Formed Steel Framing Attachment



Applications: Fasten cold-formed steel framing

Features:

- Compact body for reduced weight and easy handling
- Slim profile allows driving in corners
- Tough reliability for targeted applications

Drive These Collated Screws	
Strong-Drive® FPHSD Framing-to-CFS Screw	page 195
Strong-Drive® PHSD Framing-to-CFS Screw	page 195

Description	Model no.
Attachment Only	QDPROPHG2
Replacement Mandrel	PMANDREL65
Noseguard	PNOSEGUARD-5

Limited lifetime warranty on attachment and extension, 1-year limited warranty on screw-driver motors (see specific manufacturer's warranty for more information)

PROPH Attachment

PRORF Roofing Tile Attachment



Applications: Roofing tiles to wood

Drive These Collated Screws

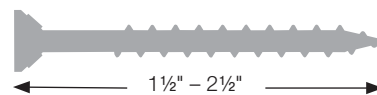

WSCD Roofing Tile Screw	page 185
WSCT Roofing Tile Screw	page 185
SSWSCB Roofing Tile Screw	page 184

Parts	Model No.
Attachment only	QDPRORFG2
Replacement mandrel	PMANDREL75

Limited lifetime warranty on attachment and extension, 1-year limited warranty on screw-driver motors (see specific manufacturer's warranty for more information)

PRORF Attachment

PRO300SRF Roofing Tile Attachment



Applications: Roofing tiles to wood

Drive These Collated Screws

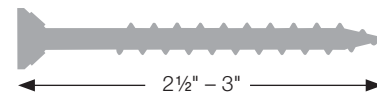

WSCD Roofing Tile Screw	page 185
WSCT Roofing Tile Screw	page 185
SSWSCB Roofing Tile Screw	page 184

Parts	Model No.
Attachment only	QDPRO300SRFG2
Replacement mandrel	PMANDREL75

Limited lifetime warranty on attachment and extension, 1-year limited warranty on screw-driver motors (see specific manufacturer's warranty for more information)

PRO300SRF Attachment

PROSD150 Steel-Decking Attachment



Applications: Steel decking to structural steel members

Drive These Collated Screws	
Self-Drilling X Metal Screw	page 197
Strong-Drive® FPHSD Framing-to-CFS screw	page 195

Parts	Model No.
Attachment only	QDPROSD150G2
Replacement 5/16" Hex Bit	BITHEXLB516LG
Replacement Hex Mandrel with 5/16" Hex Bit	BPHXLBSDG2

Limited lifetime warranty on attachment and extension, 1-year limited warranty on screw-driver motors (see specific manufacturer's warranty for more information)

PROSD150 Attachment

PROPP150 Metal Roofing Attachment



Applications: Panel clips for standing-seam roofing, steel decking to structural steel members, panel flanges for snap-and-seam metal roofing

Drive These Collated Screws	
Strong-Drive® FPHSD Framing-to-CFS Screw	page 195
PC Standing-Seam-Roofing Panel Clip Screw	page 192
PCSD Standing-Seam Roofing Panel Clip Screw	page 198
PCULP Standing-Seam-Roofing Panel Clip Screw	page 192

Self-Drilling X Metal Screw	page 197

Parts	Model No.
Attachment only	QDPROPP150G2
Replacement mandrel	PMANDREL10
Replacement hex bit and mandrel	BPHXLBPPG2

Limited lifetime warranty on attachment and extension, 1-year limited warranty on screw-driver motors (see specific manufacturer's warranty for more information)

PROPP150 Attachment

PROSDD Multi-Purpose Combo System



Applications: Decks/docks, subfloor, drywall, wallplates, stair treads fiber-cement siding to steel

- Expanded depth settings for high-density flooring materials
- Uniform toenailing and countersink on slick surfaces
- Reversible and replaceable non-skid teeth
- The patented curved collation strips (U.S. Patent 7,051,875) hold the screws up and away from the work surface, making moving and positioning the tool easier. They are also pointed on the inserted end to simplify loading.

Limited lifetime warranty on attachment and extension, 1-year limited warranty on screw-driver motors (see specific manufacturer's warranty for more information)



The PROSDD Combo System includes:

- PRO300S Decking Attachment (also sold separately)
- PRO200 Drywall Attachment (also sold separately)
- Extension
- Screwdriver motor
- Screw quiver
- Rugged toolbox

PROSDD Combo System

Quik Drive® Systems

Drive These Collated Screws



Strong-Drive® WSNTL Subfloor	page 188	SS3DSC Bugle-Head Wood Decking	page 177
Strong-Drive® PPSD Sheathing-to-CFS Screw	page 196	WSC Wood Screw	page 184
Deck-Drive™ DSV Wood Screw	page 174	PHSS Wood Screw	page 193
Deck-Drive™ DWP Wood SS Screw	page 174	WSFLRV Wood-to-CFS/Aluminum Screw	page 201
Deck-Drive™ DHPD Hardwood Screw	page 175	WSHL Subfloor	page 190
Deck-Drive™ DCSD Composite-to-Steel Screw	page 187	CBSDQ Sheathing-to-CFS Screw	page 199
Composi-Lok™ Composite-Decking	page 186	DWC Drywall Screw	page 179
Trim-Head Decking Screw: Type-17 Point	page 176	DWF Drywall-to-CFS Screw	page 200
Trim-Head Decking Screw: Sharp Point	page 176	DWFSD Drywall-to-CFS Screw	page 200

System Options	Model No.
DeWalt® 2500 rpm screwdriver motor	PROSDDD25K
Makita® 2500 rpm screwdriver motor	PROSDDM25K
Makita® 3500 rpm screwdriver motor	PROSDDM35K
Makita® 4500 rpm screwdriver motor	PROSDDM45K
Milwaukee® 2500 rpm screwdriver motor	PROSDDMW25K
Milwaukee® 4000 rpm screwdriver motor	PROSDDMW40K
Parts	Model No.
PRO300S Attachment only	QDPRO300SG2
PRO200 Attachment only	QDPRO200G2
Replacement PRO300S attachment mandrel	PMANDREL75
Replacement PRO200 attachment mandrel	PMANDREL65

PROCCS+ Multi-Purpose Combo System

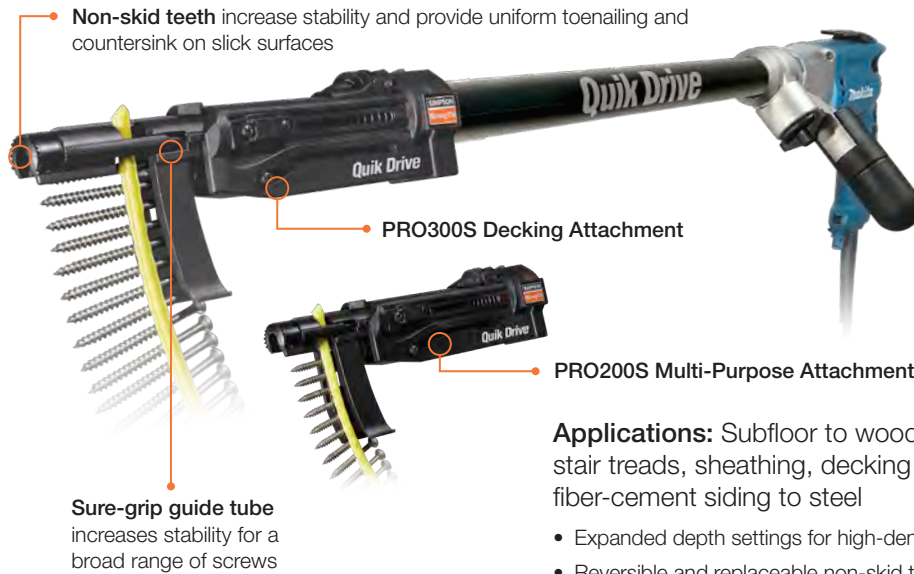

Applications: Subfloor to wood or steel, wall plates, stair treads, sheathing, decking on decks and docks, fiber-cement siding to steel

- Expanded depth settings for high-density flooring materials
- Reversible and replaceable non-skid teeth
- Sure-grip guide tube increases stability for a broad range of screws
- The patented curved collation strips (U.S. Patent 7,051,875) hold the screws up and away from the work surface, making moving and positioning the tool easier. They are also pointed on the inserted end to simplify loading.

Limited lifetime warranty on attachment and extension, 1-year limited warranty on screw-driver motors (see specific manufacturer's warranty for more information)



The PROCCS+ Combo System includes:

- PRO300S Decking Attachment (also sold separately)
- PRO200S Multi-Purpose Attachment (also sold separately)
- Extension
- Screwdriver motor
- Screw quiver
- Rugged toolbox

Quik Drive® Systems

PROCCS+ Combo System

Drive These Collated Screws



Strong-Drive® WSNTL Subfloor Screw	page 188	PHSS Wood Screw	page 193
Deck-Drive™ DWP Wood SS Screw	page 174	WSC Wood Screw	page 193
Deck-Drive™ DHPD Hardwood Decking	page 175	WSFLRV Wood-to-CFS/Aluminum	page 201
Deck-Drive™ DCSD Composite Decking	page 187	WSHL Subfloor	page 190
Composi-Lok™ Composite-Decking	page 186	Strong-Drive® PPSD Subfloor-to-CFS	page 196
Trim-Head Decking Screw: Type-17 Point	page 176	MTH Wood Underlayment Screw	page 191
Trim-Head Decking Screw: Sharp Point	page 176	CBSDQ Sheathing-to-CFS Screw	page 199
SS3DSC Bugle-Head Wood Decking	page 177		

System Options	Model No.
DeWalt® 2500 rpm screwdriver motor	PROCCS+D25K
Makita® 2500 rpm screwdriver motor	PROCCS+M25K
Parts	Model No.
PRO300S Attachment only	QDPR0300SG2
PRO200S Attachment only	QDPR0200SG2
Replacement attachment mandrel	PMANDREL75

For more information on screwdriver motors and RPM recommendations per application, see pages 260-262.

PROCGB Underlayment/Backerboard Combo System



Applications: Cement board and fiber-cement board underlayment to wood or steel, backerboard to wood or steel, gypsum panel to wood or steel

- QDPRO200SG2 attachment is ideal for gypsum panel
- Extension allows stand-up driving and gets installers off of their knees
- Compact body for reduced weight and easy handling

Limited lifetime warranty on attachment and extension, 1-year limited warranty on screw-driver motors (see specific manufacturer's warranty for more information)



The PROCGB Combo System includes:

- PROLDH Underlayment/Backerboard Attachment (also sold separately)
- PRO200S Multi-Purpose Attachment (also sold separately)
- Auto-feed attachment
- Extension
- Screwdriver motor
- Screw quiver
- Rugged toolbox

PROCGB Combo System

Quik Drive® Systems

Drive These Collated Screws	
CB3BLG Fiber-Cement Board Screw	page 177
CB3BLGHL Cement Board Screw	page 178
CBSDQ Sheathing-to-CFS Screw	page 199
DWC Drywall Screw	page 190
DWF Drywall-to-CFS Screw	page 200
DWFS Drywall-to-CFS Screw	page 200
MTH Wood Underlayment Screw	page 191

System Options	Model No.
Makita® 2500 rpm screwdriver motor	PROCGBM25K
Parts	Model No.
PROLDH Attachment only	QDPROLDHG2
PRO200S Attachment only	QDPRO200SG2
Replacement attachment mandrel (QDPROLDHG2)	PMANDREL65
Replacement attachment mandrel (QDPRO200SG2)	PMANDREL75

For more information on screwdriver motors and RPM recommendations per application, see pages 260-262.

Quik Drive® – Screwdriver Motors

Quik Drive® Systems are available with a variety of screwdriver motors.

The information below will aid in the selection of the right tool for the intended application. Not all motors are available with all systems, reference the appropriate systems page for available options.

Screwdriver Motors Sold in Quik Drive Systems

					
Description*	DeWalt® 2500 rpm 6.5 amp 132 in/lbs peak torque*	Makita® 2500 rpm 6.5 amp 133 in/lbs peak torque*	Makita 3500 rpm 6.5 amp 107 in/lbs peak torque*	DeWalt® 2000 rpm 5.5 amps Adjustable torque*	Makita 2500 rpm 6 amp Adjustable torque*
Features	Multi-application versatility	Multi-application versatility	Increased speed for low-torque applications	Adjustable torque	6 torque settings, ideal for steel-framing applications
Quik Drive Model Number	DW276QD	MAFS2500	MAFS3500	DW267QD	MAFS2701
Available in these Quik Drive Systems					
PRO200	PRO200G2D25K	PRO200G2M25K	—	—	—
PRO250	PRO250G2D25K	PRO250G2M25K	PRO250G2M35K	—	—
PRO300S	PRO300SD25K	PRO300SM25K	PRO300SM35K	—	—
PROCCS+	PROCCS+D25K	PROCCS+M25K	—	—	—
PROGCB	—	PROGCBM25K	—	—	—
PROLDH	—	PROLDHG2M25K	—	—	—
PROPP150	—	PROPP150G2M25K	—	—	PROPP150G2MATK
PROSD150G2	—	—	—	PROSD150G2DATK	—
PRORF	—	PRORFG2M25K	PRORFG2M35K	—	—
PRO300SRF	—	PRO300SRFG2M25K	PRO300SRFG2M35K	—	—
PROSDD	PROSDD25K	PROSDDM25K	PROSDDM35K	—	—
PROHSD60	—	PROHSD60M25K	—	—	—
PROHSD75	—	—	—	—	—

*This information provided by screwdriver motor manufacturers. All screwdriver motors may also be purchased separately using the tool model number.

Quik Drive® – Screwdriver Motors (cont.)

Screwdriver Motors Sold in Quik Drive® Systems

				
Description*	Hitachi® 1700 rpm 6.6 amps 215 in/lbs peak torque*	Makita 1000-2000 rpm 4.6 amp (2 speeds) 177 in/lbs peak torque*	Milwaukee 2500 rpm 6.5 amp 120 in/lbs peak torque*	Milwaukee 4000 rpm 6.5 amp 77 in/lbs peak torque*
Features	Increased power for high-torque applications	2 speeds for heavy-gauge steel applications	Multi-application versatility	Increased speed for low-torque applications
Quik Drive Model Number	HIW8VB2	MA6807Z	MW6790	MW6742

Available in these Quik Drive Systems

PRO200	—	—	—	—
PRO250	—	—	PRO250MW25K	PRO250G2MW40K
PRO300S	—	—	PRO300SMW25K	PRO300SMW40K
PROCCS+	—	—	—	—
PROCGB	—	—	—	—
PROLDH	—	—	—	—
PROPP150	—	—	—	—
PRORF	—	—	—	—
PRO300SRF	—	—	—	—
PROSDD	—	—	PROSDDMW25K	PROSDDMW40K
PROHSD60	PROHSD60H17K	PROHSD60MVK	—	—
PROHSD75	PROHSD75H17K	PROHSD75MVK	—	—

*This information provided by screwdriver motor manufacturers. All screwdriver motors may also be purchased separately using the tool model number.

Screwdriver Motors – Sold Separately

This tool is not available in a system, and must be ordered separately.

	Description	Features	Tool Model No.
	Makita 6000 rpm 6.0 amps	Maximum speed for drywall applications	MAFS6200

Quik Drive® – Auto-Feed Screw Driving Systems

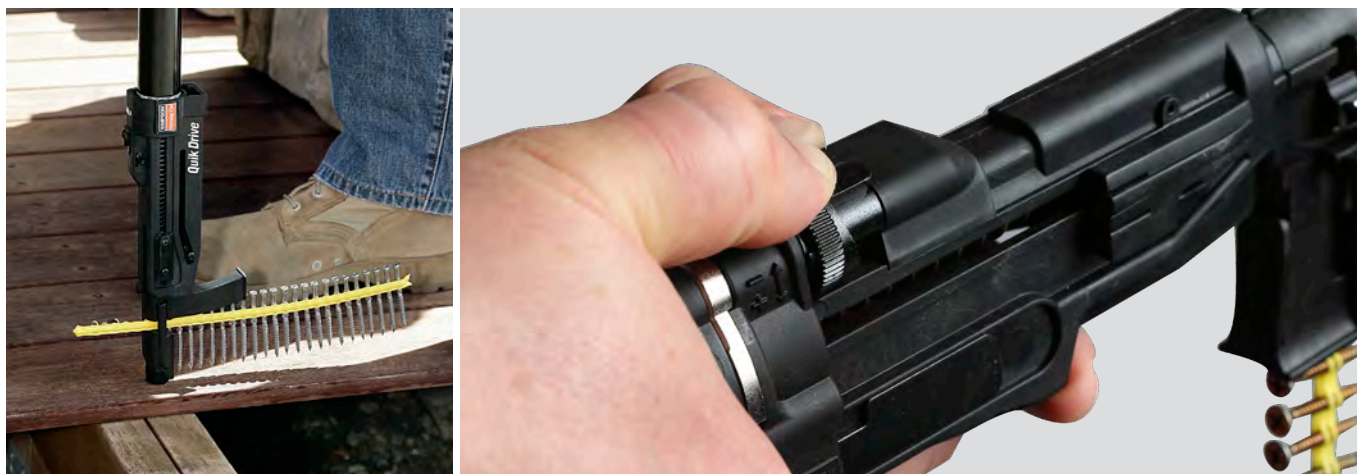

Quik Drive® Adjustable Countersink Feature

The adjustable countersink on Quik Drive® auto-feed attachments allows the user to dial-in fastener penetration to match the material and application. Once the countersink depth is set, the driver bit automatically disengages from the head of the screw when the desired penetration is achieved, preventing over-driving. Screws can be driven to the right depth every time without the user having to slow down to check each fastener, making for faster work and more consistent results.

Some things to consider when using the countersink feature:

- Test and adjust the countersink depth using a scrap piece of lumber.
- Stainless-steel screws are softer than carbon steel screws. Therefore, care should be taken to set the countersink adjustment wheel to a drive depth that will not over drive the screw during installation. Overdriving stainless-steel screws can cause breakage.

Screwdriver Motor RPM Recommendations

Simpson Strong-Tie offers a large selection of screwdriver motors for Quik Drive auto-feed screw driving systems. It is important to select a motor with RPM specifications that suit the intended application(s) to ensure the best results. See the full selection of screwdriver motors on pages 260-261.

Screwdriver Motor RPM Recommendations Per Application

Applications	Cordless	1700 rpm	2500 rpm	3500 rpm	4000 rpm	6000 rpm	2000 rpm Adjustable Torque	2500 rpm Adjustable Torque	1000-2000 rpm 2 Speed
Subfloor and Sheathing	—	—	Better	Best	Good	—	—	—	—
Decks/Docks	—	Better	Best	Better	Good	—	—	—	—
Drywall	—	—	Good	Better	Best	Better	—	—	—
Fiberglass-Mat Gypsum Sheathing	—	—	Good	Better	Best	Better	—	—	—
Fiber-Cement Siding	—	Good	Best	Good	—	—	—	—	—
Tile Roofing	—	—	Best	Better	—	—	—	—	—
Metal Roofing and Siding	Good	—	Best	Better	Good	—	—	—	—
Steel Framing	Good	Good	Best	Good	—	—	Good	Good	—
Steel Decking	—	—	—	—	—	—	Best	Better	—
Steel Stitching	—	—	Good	—	—	—	Best	Best	—
Underlayment and	Good	Better	Best	Better	Good	—	—	—	—
Truck and Trailer Beds	—	Best	Good	—	—	—	—	—	Best
Remodeling and General Purpose	Good	—	Best	Better	—	—	—	—	—

Quik Drive® – Adaptors

Adaptors for Most Popular Screwdriver Motors

Screwgun	QD adaptor	Screwgun	QD adaptor	Screwgun	QD adaptor
AEG®		HILTI®		METABO®	
SE4000	MIAG2	SD2500	HTAG2	SE 5025	MEAG2
ATLAS COPCO®		SD5000	HTAG2	SE 5040	MEAG2
PRO2000	MIAG2	SF4000	HTAG2	SE2800	ADMETABOG2
		SD4500	HTAG2	S4000	ADMETABOG2
		ST1800-A18	HT18G2		
BOSCH®		HITACHI®		MILWAUKEE®	
GSR645TE	BOA1G2	W6V3	HIAG2	6708-21	MIAG2
SG25	BOA1G2	W8VB2	HIAG2	6707-20	MIAG2
SG45	BOA1G2	WH18DMR	HIA1G2	6742-20	MIAG2
SG250	BOA1G2			6743-20	MIAG2
SG450	BOA1G2			6743-50	MIAG2
CHICAGO PNEUMATIC®		MAKITA®		6743-55	MIAG2
RP2780	CPAG2	6807	MAA6807G2	6745-1	MIAG2
DEWALT®		6821	MAAG2	6746-1	MIAG2
252	DWAG2	6823	MAAG2	6755-4	MIAG2
254	DWAG2	6832	ADM31DG2	6758	MIAG2
255	DWAG2	6833D	ADM31DG2	6760	MIAG2
257	DWAG2	6834	ADM34G2	6790-1	MIAG2
260	DWAG2	6835D (cordless)	ADM34G2	6791-20	MIAG2
265	DWAG2	FR440D (cordless)	ADM31DG2		
266	DWAG2	BFR750 (cordless)	ADM31DG2	PORTER CABLE®	
267	DWA3G2	BFS450 (cordless)	MAA2G2	4630	PCAG2
268	DWA3G2	BTD141 (cordless)	MAA1G2	4634	PCAG2
272	DWAG2	BTD142HW (cordless)	MAA1G2	4640	PCAG2
274	DWAG2	BTD144 (cordless)	MAA1G2		
275	DWAG2	FS2701	MAA4G2	SIUOX®	
520 (cordless)	DWA1G2	FS2200	MAA3G2	2P2603A	SXAG2
895 (cordless)	DWA4G2	FS2500	MAA3G2	2P2303A	SXAG2
969 (cordless)	DWA3G2	FS4200	MAA3G2	2S2303A	SXAG2
825 (cordless)	DWAG2	FS6200	MAA3G2	2P2603AQ	SXA1G2
827 (cordless)	DWAG2	LXSF01 (cordless)	MAA3G2	2P2303AQ	SXA1G2
835 (cordless)	DWAG2	LXDT04 (cordless)	MAA6G2	2P2603ASQ	SXA1G2
845 (cordless)	DWAG2	FS2701 (cordless)	MAA4G2	2P2303ASQ	SXA1G2
855 (cordless)	DWAG2			SSD10P20PS	SXA2G2

Quik Drive – Swivel Adaptors

- Rotates 360° without having to detach the tool from motor
- Allows the use of one hand to rotate tool
- Easily rotate screws out of the way for corner applications

Screwgun	QD Adaptor
DEWALT®	
252	DWASWG2
254	DWASWG2
255	DWASWG2
257	DWASWG2
260	DWASWG2
265	DWASWG2
266	DWASWG2
267	DWASWG2
268	DWASWG2
272	DWASWG2
274	DWASWG2
275	DWASWG2
277	DWASWG2
276	DWASWG2
281	DWASWG2
284	DWASWG2
HILTI	
SD4500	HTASWG2

Quik Drive® – Replacement Parts

Part	Model No
Bit key for Quik Drive tools	BITKEY
Bit pack – 3 ea. Phillips-drive bit	BIT2P-RC3
Bit pack – 3 ea. square-drive bit	BIT2S-RC3
Bit pack – 3 ea. #2 undersized square-drive bit	BIT2SU-RC3
Bit pack – 3 ea. square drive	BIT3S-RC3
Bit pack – 3 ea. #3 undersize square drive	BIT3SU-RC3
Bit pack – 10 ea. #2 Phillips-drive bit	BIT2P-RC10
Bit pack – 10 ea. #2 square-drive bit	BIT2S-RC10
Bit pack – 10 ea. #2 undersize square-drive bit	BIT2SU-RC10
Bit pack – 10 ea. #3 square-drive bit	BIT3S-RC10
Bit Pack – 10 ea. #3 undersize square-drive bit	BIT3SU-RC10
Bit Pack – 10 ea. T-25 6 Lobe	BITTX25-RC10
Bit pack – 3 ea. 6-lobe drive	BITTX25-RC3
Driver bit, hex 5/16"	BITHEX516
Driver bit, lobular, hex 5/16"	BITHEXLB516
Driver bit, lobular, hex head, 1/4"	BITHEXLB14
Mandrel, BGP, with lobular 5/16" driver bit for PROPPSD tool	BPHXLBSD2
Leafspring, HSD, HX14 attachments	QDLEAFSPRING
Leafspring, HX516, PH, LDH, PP150, SD150 attachments	QDLEAFSPRING2
Mandrel, QDA158NS attachment	PMANDREL158
Mandrel, BGP, with lobular 1/4" driver bit	BPHXLBGP14G2
Mandrel, BGP, with lobular 5/16" driver bit	BPHXLBGP516G2
Driver bit, lobular, hex 5/16" for PROPPSD tool	BITHEXLB516LG
Mandrel, 5 1/2"	PMANDREL55
Mandrel, 6"	PMANDREL6
Mandrel, 6 1/2"	PMANDREL65-RC
Mandrel, 7 1/2"	PMANDREL75-RC
Mandrel, 10"	PMANDREL10
Mandrel, 5/16" hex with driver bit for PP150 series attachment	BPHXLBPPG2
Mandrel, for QDEXTG2-16	PMANDRELEXTG2-16
Mandrel, HX516 attachment, with 5/16" driver bit	BPHX516G2
Mandrel, 5/16" hex with driver bit for SD150 series attachment	BPHXLB5G2



QDLEAFSPRING2



PMANDREL75-RC

Drive Types and Replacement Driver Bits

It is necessary to use the right driver bit to ensure optimum results with a Quik Drive system. The bit(s) included in each box of Quik Drive screws should be sufficient to drive the entire box, however variations in materials and driving techniques can shorten driver-bit life. Replacement bits are available in Bit Packs; reference the label on the bit included in the box or the box label to ensure correct driver-bit selection (see table above for Bit Pack quantities and model numbers).

Drive Type/Size	Bit	Description
#2 square drive	R2	BIT2S – for most screws with #2 recess and interior-grade coating
#2U (#2 undersized)	R2U	BIT2SU – for most screws with #2 recess and exterior-grade coating
#3 square drive	R3	BIT3S – for most screws with #3 recess and interior-grade coating
#3U (#3 undersized)	R3U	BIT3SU – for most screws with #3 recess and exterior-grade coating
#2 phillips		BIT2P – for all Quik Drive screws with phillips recess
1/4" lobular hex drive	P2	BITHEXLB14 – For most screws with 1/4" lobular hex drive
5/16" lobular hex drive		BITHEXLB516 – For most screws with 5/16" lobular hex drive
T-25 Lobe		BITTX25 – For Quik Drive systems with T-25 6-lobe drive



BIT3S-RC10

Quik Drive® – Accessories

Accessories	Model NO.
Adjusting arm, BGP300G2 (profile guide not included)	PADJARMBGP300G2
Feed pawl, 250, 200S, 300S attachments	PFEEDPAWL
Feed pawl, twist lock for SDS, 200 attachments	PFEEDPAWLT
Feed pawl, HSD attachments	PFEEDPAWL3
Feed pawl, HX, PH, LDH, PROPP attachments	PFEEDPAWL2
Feed Pawl PP, PH, SD attachments	PFEEDPAWL5

Replacment Parts	Model NO.
Case, PRO kits	TOOLCASE-LG
Deck clip, PRO300S, PRO200S, PRO250	QDDECKCLIP-RC
Extension, 16" (short), G2 series	QDEXTG2-16
Extension, 20" (standard), G2 series	QDEXTG2
Extension, 22" (long), G2 series	QDEXTG2-22
Extension, 22" (long), G2 series, "T" handle (two hands)	QDEXTG2-T
Extension replacement handle, G2 Series	G2HANDLE
Noseclip, 250, 200S, 300S attachments	PNOSECLIP
Noseguard, HX516 attachment	PNOSEGWARD-5
Profile guide, 5V	PPROFILEGUIDE5V
Profile guide, AG panel ¼" Rib	PPROFILEGUIDE32
Profile guide, corrugated ½" H x 2¾" W	PPROFILEGUIDE22
Profile guide, corrugated ⅞" H x 2¾" W	PPROFILEGUIDE23
Profile guide, flat	PPROFILEGUIDE11
Profile guide, J Rib / 4-Rib	PPROFILEGUIDE33
Profile guide, Maxi Rib	PPROFILEGUIDE34
Screw quiver, worn on belt, carries up to 500 screws	QUIVER



Quik Drive® – Schematics and Troubleshooting

System Components

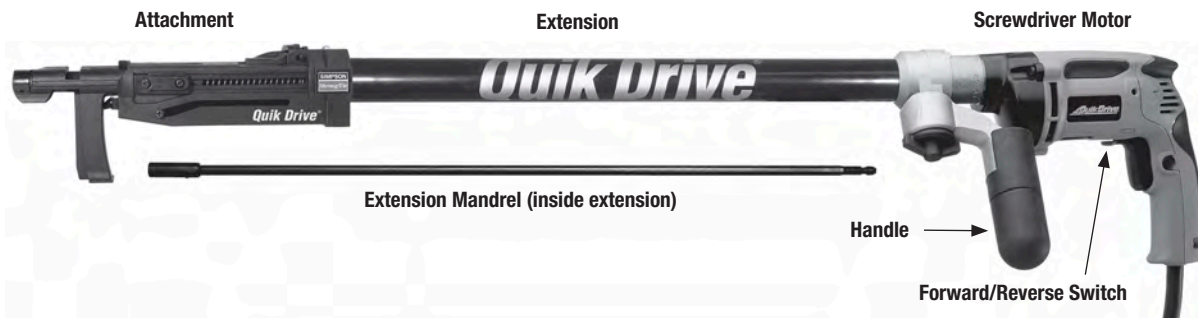

Schematic

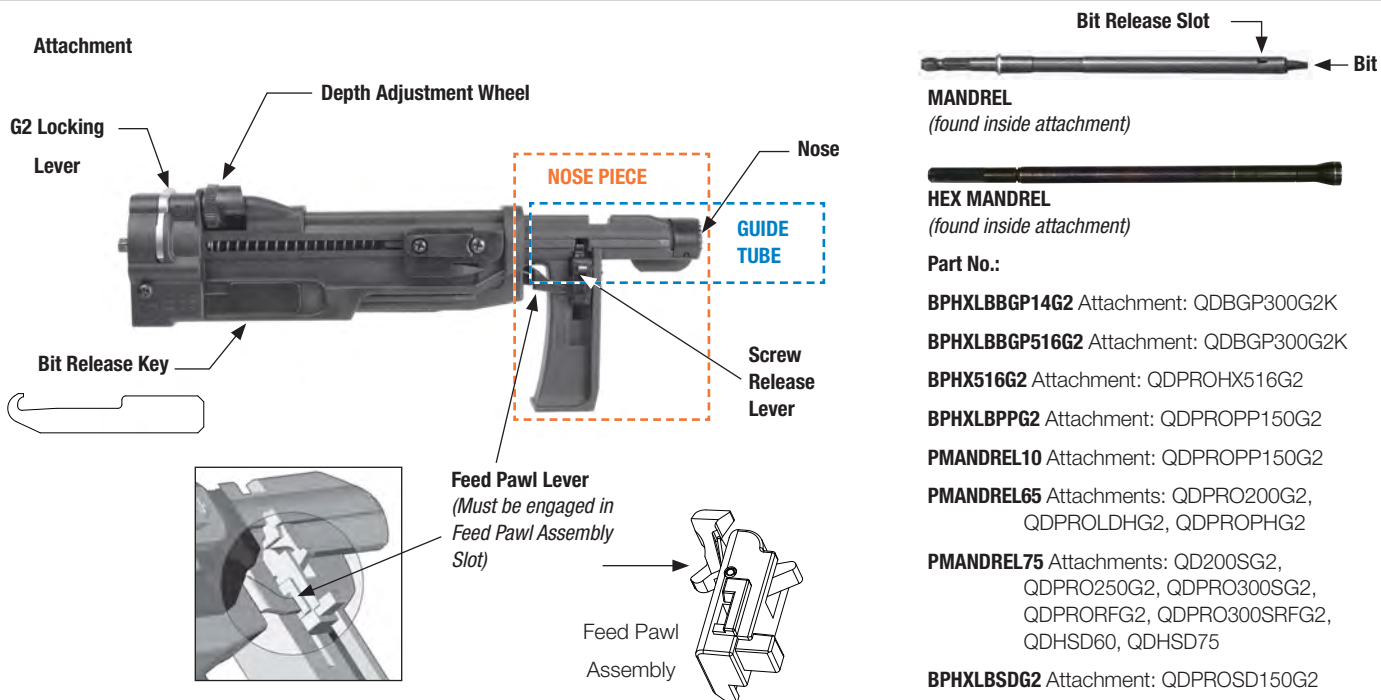

Troubleshooting Guide

Simpson Strong-Tie® Quik Drive® tools are easy to use. As with any power tool, there are a few basic things to remember for best performance.

Problem	Solution
Screws won't drive. They spin for a second, then lay over on their side. Little or no penetration.	Make sure the screwdriver motor is not in reverse.
Screws won't drive completely. They go down about halfway, then the bit spins out.	Check to be sure you are using the correct bit for the type of screws you are driving. Check for bit wear. It may be time to install a new bit. Push harder when driving.
Screws won't drive completely. They are almost completely driven but won't countersink completely.	Check the depth adjustment on the attachment. Reset if necessary. You may have missed the substrate. Example: In flooring, this will occur if you miss the joist.
Screws don't advance properly causing tool to jam	Use only Simpson Strong-Tie Quik Drive brand collated screws. Be sure the screw strip is inserted correctly – pointed end first. Lift the tool completely off the work surface after driving each screw. Don't drag screw strips on the work surface as you move to the next position. Be sure the feed pawl assembly is intact and feed lever is engaged.

Quik Drive® - Warranty

Limited Warranty On Quik Drive® Tool

This Limited Lifetime Warranty applies to all Quik Drive tools and must be read in conjunction with the General Notes, Terms and Conditions of Sale, and Corrosion Resistance information contained in the current Quik Drive catalog and at www.strongtie.com/info, along with any information provided with a Simpson Strong-Tie Company Inc. ("Simpson") product. Screwguns, screw driver motors and batteries that may be supplied with the Quik Drive tools are manufactured by others and are warranted only by their respective manufacturers. Simpson Strong-Tie warrants the Quik Drive tools to the original purchaser to be free from substantial defects in material, manufacturing, and design for the lifetime of the product, if properly stored, maintained and used. This Warranty does not cover normal wear and tear or any Quik Drive tool that was: (1) purchased other than from an authorized Simpson Strong-Tie dealer, retailer or distributor; (2) modified or altered; (3) used with any fasteners other than authentic Quik Drive fasteners; (4) improperly serviced; or (5) subject to negligence, excessive uses, or any use not in accordance with the printed materials provided with the Quik Drive tool as determined by Simpson Strong-Tie. Purchaser's sole remedies are replacement or repair upon return to Simpson Strong-Tie with proof of purchase (shipping prepaid by purchaser). To obtain warranty service go to www.strongtie.com or contact Simpson Strong-Tie promptly at (800) 999-5099. The repaired or replaced Quik Drive tool is warranted under the terms of this Warranty.

SIMPSON DISCLAIMS ALL OTHER WARRANTIES, EXPRESS OR IMPLIED, INCLUDING BUT NOT LIMITED TO IMPLIED WARRANTIES OF MERCHANTABILITY AND FITNESS FOR A PARTICULAR PURPOSE. IN NO EVENT WILL SIMPSON BE LIABLE FOR INCIDENTAL, CONSEQUENTIAL, PUNITIVE OR SPECIAL DAMAGES OR DIRECT OR INDIRECT LOSS OF ANY KIND, INCLUDING BUT NOT LIMITED TO PROPERTY DAMAGE AND PERSONAL INJURY. SIMPSON'S ENTIRE LIABILITY IS LIMITED TO THE PURCHASE PRICE OF THE PRODUCT. SOME STATES DO NOT ALLOW LIMITATIONS ON IMPLIED WARRANTIES, OR THE EXCLUSION OR LIMITATION OF INCIDENTAL OR CONSEQUENTIAL DAMAGES, SO THE ABOVE LIMITATIONS AND EXCLUSIONS MAY NOT APPLY TO YOU. THIS LIMITED WARRANTY GIVES YOU SPECIFIC LEGAL RIGHTS, AND YOU MAY ALSO HAVE OTHER RIGHTS THAT VARY FROM STATE TO STATE.

Safety Warnings

Additional Quik Drive® Safety Warnings

- a. Keep work area clean and well lit.
- b. Do not operate Simpson Strong-Tie® Quik Drive® tools in dangerous environments. Do not expose tools to rain or use them in damp or wet locations. The use of Quik Drive tools can create sparks. Do not use in the presence of flammable liquids, dust or gases.
- c. Keep bystanders, children and visitors away while operating a Quik Drive Tool. Distractions can cause accidents and serious bodily injury.

Reduce Risk of Electrical-Related Accidents

- a. Guard against electrical shock. Prevent body contact with grounded surfaces.
- b. Never modify the tool power plug in any way. Always use a plug with a matching outlet. Use of proper, unmodified plugs and outlets reduces the risk of electric shock.
- c. Do not abuse the power cord. Never carry a tool by its cord or pull the cord to disconnect from an outlet or other receptacle. Keep cord away from heat, oil, sharp edges or moving parts. Replace damaged cord immediately. Damaged cords increase the risk of electrical shock.
- d. When operating a tool outside, use extension cords suitable for outdoor use.

Personal Safety

- a. Stay alert. Do not use a Quik Drive system while tired or under the influence of drugs, alcohol or medication. Use common sense when operating the tool. Inattention while operating Quik Drive system may result in serious bodily injury.
- b. Dress properly when using a Quik Drive system. Do not wear loose clothing or jewelry. Keep your hair, clothing and gloves away from moving parts. Loose clothes, long hair or jewelry can be caught in moving parts and result in serious bodily injury. Be sure the power switch on a tool is in the off position before plugging in the tool. Do not carry tools with your finger on the switch.
- c. Keep proper footing and balance at all times.
- d. Always use safety equipment, such as protective glasses, dust masks, non-skid safety shoes, safety harnesses hard hats and/or earplugs.

Quik Drive Tool Use and Care

- a. Do not force the Quik Drive tool. Use the correct tool for the application.
- b. When not in use, Quik Drive systems should be stored in a dry place and out of the reach of children and other untrained persons.
- c. Disconnect the plug from power source before making adjustments, changing accessories or storing tool.
- d. Maintain Quik Drive tools with care. Follow instructions for changing accessories.
- e. Regularly check for misalignment or binding of moving parts and other conditions that may affect operation.
- f. Use only accessories recommended by Simpson Strong-Tie Company Inc.
- g. Any repairs to electric tools should be performed by qualified personnel. Use only authorized parts.

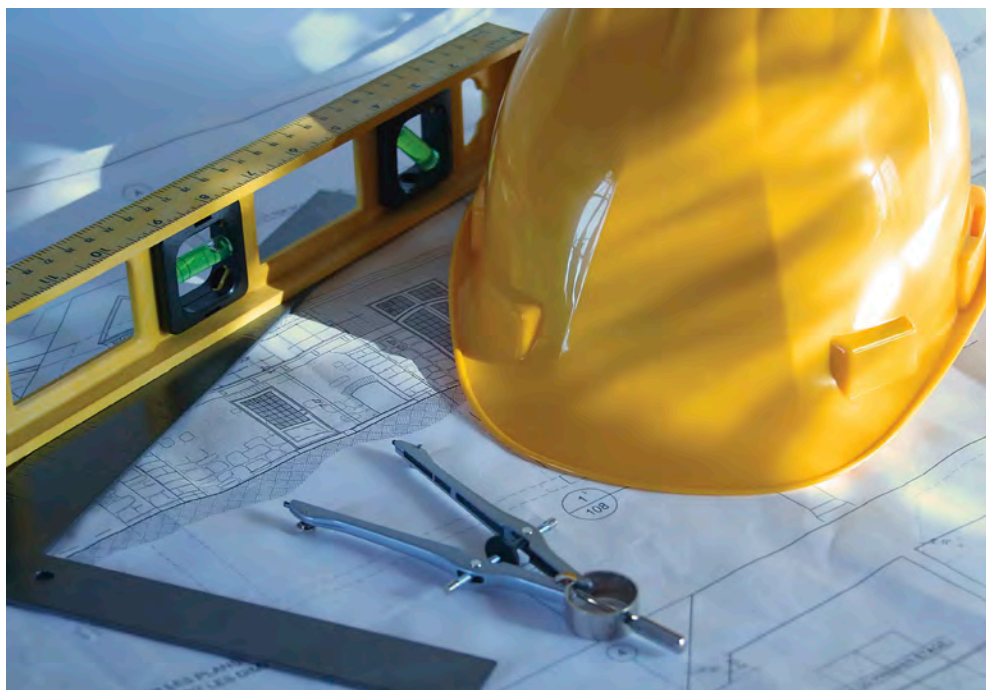

General Material Safety Data (MSDS) Note

Material Safety Data Sheets (MSDS)

For Fasteners

Simpson Strong-Tie Company Inc. manufactures and sells fasteners, metal connectors and mechanical concrete anchors. Fastener products include and are not limited to nails, screws and staples. For the purpose of hazard communication, fastener products are “Articles” as defined in 29 CFR 1910.1200(c):

“Article means a manufactured item other than a fluid or particle: (i) which is formed to a specific shape or design during manufacture; (ii) which has end use function(s) dependent in whole or in part upon its shape or design during end use; and (iii) which under normal conditions of use does not release more than very small quantities, e.g., minute or trace amounts of a hazardous chemical (as determined under paragraph (d) of this section), and does not pose a physical hazard or health risk to employees.”

As Articles, fastener products are exempt from Material Safety Data Sheet (MSDS) requirements under the Hazard Communication Standard (29 CFR 1910.1200(b)(6)(v)). For this reason, Simpson Strong-Tie does not have available MSDS sheets for its fastener products.

This information is current as of the date of this publication and is subject to change without notice. See www.strongtie.com for possible updates.

General Load Tables

Screw Strength

Model No.	Screw Size	Nominal Strength (lbs.)		Load Resistance Factor Design (LRFD) (lbs.)		Allowable Stress Design (ASD) (lbs.)	
		Shear	Tension	Shear	Tension	Shear	Tension
		P_{ss}	P_{ts}	ϕP_{ss}	ϕP_{ts}	P_{ss}/Ω	P_{ts}/Ω
Steel to Steel							
FPHSD34S1016	#10 x ¾"	1710	2215	895	1110	570	740
FPHSD34S1214	#12 x ¾"	2535	3380	1320	1690	845	1125
PHSD34S0818	#8 x ¾"	1495	1810	750	905	500	605
E1B1414	#14 x 1"	3130	5395	1565	2700	1045	1800
Steel Decking							
X1S1016	#10 x 1"	1835	2885	920	1145	610	960
X1S1214	#12 x 1"	2485	4045	1240	2020	830	1350
XEQ34B1016	#10 x ¾"	1545	2355	775	1180	515	785
XQ78S1224	#12 x 7/8"	2800	4260	1400	2130	935	1420
XQ114S1224	#12 x 1¼"	2800	4260	1400	2130	935	1420
XQ112S1224	#12 x 1½"	2800	4260	1400	2130	935	1420
Metal-Roofing Clip to Steel							
PCSD1S1016	#10 x 1"	1705	2380	850	1190	570	795
PCSD1S1214	#12 x 1"	1760	3180	880	1590	585	1060
SSPCSD1S1016	#10 x 1"	1892	3045	985	1588	631	1015
Metal-Roofing Clip to Wood							
PC1BS1012	#10-12 x 1"	1415	2080	710	1040	470	695
PC1BS1211	#12-11 x 1"	1715	3080	860	1540	570	1025
PCULP1BS1012	#10-12 x 1"	1625	2275	815	1140	540	760
Drywall							
DWF1PS	#6 x 1"	1255	1575	630	790	420	525
DWF114PS	#6 x 1¼"	1255	1575	630	790	420	525
DWF158PS	#6 x 1½"	1255	1575	630	790	420	525
DWFSD114PS	#6 x 1¼"	1260	1720	630	860	420	575
DWFSD158PS	#6 x 1½"	1260	1720	630	860	420	575
DWFSDG114PS	#6 x 1¼"	1260	1720	630	860	420	575
DWFSD178PS	#6 x 17/8"	1260	1720	630	860	420	575
DWFSD238PS	#8 x 2¾"	1260	1720	630	860	420	575
Wood to Steel							
FHSD114S0818	#8 x 1¼"	1221	1884	637	983	407	628
SSFHSD112S1016	#10 x 1½"	2275	3435	1140	1720	760	1145
PPSD11516S	#8 x 11/16"	1565	2160	785	1080	520	720
TB1445S	#14 x 1¾"	3690	4625	1845	2315	1230	1540
TB1460S	#14 x 2¾"	3690	4625	1845	2315	1230	1540
TB1475S	#14 x 3"	3690	4625	1845	2315	1230	1540

1. Table based on testing per AISI Standard Test Method S904-08.
2. Factor of Safety (Ω), and Resistance Factor (ϕ) are determined per AISI S100-07 Section F1.
3. P_{ss} and P_{ts} are nominal shear strength and nominal tension strength values for the screw itself, respectively, and are also known as the average (ultimate) values of all tests; determined by independent laboratory testing.

Load Tables, Technical Data and Installation Instructions

Strong-Drive® SDWS TIMBER Screw

Structural Wood-to-Wood Connections including Ledgers

Designed to provide an easy-to-install, high-strength alternative to through-bolting and traditional lag screws. The SDWS structural wood screws are ideal for the contractor and do-it-yourselfer alike.

Double-barrier coating provides corrosion resistance equivalent to hot-dip galvanization, making it suitable for certain exterior and preservative-treated wood applications, as described in the evaluation report.

Codes/Standards: IAPMO-UES ER-192, State of Florida FL13975;
U.S. Patents 5,897,280; 7,101,133

For More Product Information, see page 58

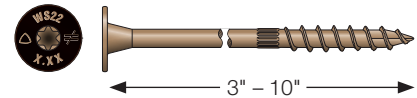

SDWS – Allowable Shear Loads – Douglas Fir-Larch and Southern Pine Lumber

Size Dia. x L (in.)	Model No.	Thread Length (in.)	DF/SP Allowable Shear Loads (lbs.)									
			Wood Side Member Thickness (in.)									
			1.5	2	2.5	3	3.5	4	4.5	6	8	
0.220 x 3	SDWS22300DB	1½	255	—	—	—	—	—	—	—	—	—
0.220 x 4	SDWS22400DB	2¾	405	405	305	—	—	—	—	—	—	—
0.220 x 5	SDWS22500DB	2¾	405	405	360	360	325	—	—	—	—	—
0.220 x 6	SDWS22600DB	2¾	405	405	405	405	365	365	355	—	—	—
0.220 x 8	SDWS22800DB	2¾	405	405	405	405	395	395	395	395	—	—
0.220 x 10	SDWS221000DB	2¾	405	405	405	405	395	395	395	395	395	395

See footnotes below.

SDWS – Allowable Shear Loads – Spruce-Pine-Fir and Hem-Fir Lumber

Size Dia. x L (in.)	Model No.	Thread Length (in.)	SPF/HF Allowable Shear Loads (lbs.)									
			Wood Side Member Thickness (in.)									
			1.5	2	2.5	3	3.5	4	4.5	6	8	
0.220 x 3	SDWS22300DB	1½	190	—	—	—	—	—	—	—	—	—
0.220 x 4	SDWS22400DB	2¾	385	285	215	—	—	—	—	—	—	—
0.220 x 5	SDWS22500DB	2¾	405	290	290	290	195	—	—	—	—	—
0.220 x 6	SDWS22600DB	2¾	405	365	365	365	310	310	210	—	—	—
0.220 x 8	SDWS22800DB	2¾	405	365	365	365	310	310	280	280	—	—
0.220 x 10	SDWS221000DB	2¾	405	365	365	365	310	310	280	280	280	280

- All applications are based on full penetration into the main member. Full penetration is the screw length minus the side member thickness.
- Allowable loads are shown at the wood load duration factor of $C_D = 1.0$. Loads may be increased for load duration per the building code up to a $C_D = 1.6$. Tabulated values must be multiplied by all applicable adjustment factors per the NDS.
- Minimum fastener spacing requirements to achieve table loads: 6" end distance, 1½" edge distance, ¾" between staggered rows of fasteners, 4" between non-staggered rows of fasteners and 8" between fasteners in a row.
- For in-service moisture content greater than 19%, use $C_M = 0.7$.
- Loads are based on installation into the side grain of the wood with the screw axis perpendicular to the face of the member.

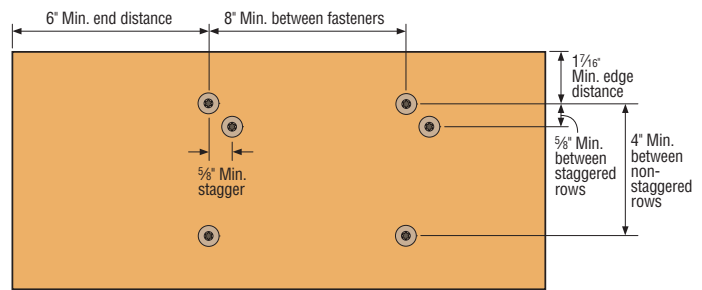

SDWS Spacing Requirements

SDWS – Allowable Withdrawal Loads – Douglas Fir-Larch, Southern Pine, Spruce-Pine-Fir and Hem-Fir Lumber

Model No.	Fastener Length (in.)	Thread Length (in.)	Reference Withdrawal Design Value, W (lbs./in.)		Max. Reference Withdrawal Design Value, W _{Max} (lbs.)	
			DF and SP Main Member	HF and SPF Main Member	DF and SP Main Member	HF and SPF Main Member
SDWS22300DB	3	1½	164	151	245	225
SDWS22400DB	4	2¾	179	160	425	380
SDWS22500DB	5	2¾	214	187	590	495
SDWS22600DB	6	2¾	214	187	590	495
SDWS22800DB	8	2¾	214	187	590	495
SDWS221000DB	10	2¾	214	187	590	495

- The tabulated reference withdrawal design value, W , is in pounds per inch of the thread penetration into the side grain of the main member.
- The tabulated reference withdrawal design value, W_{Max} , is in pounds where the entire thread length must penetrate into the side grain of the main member.
- Tabulated reference withdrawal design values, W and W_{Max} , are shown at a $C_D = 1.0$. Loads may be increased for load duration per the building code up to a $C_D = 1.6$. Tabulated values must be multiplied by all applicable adjustment factors from the NDS as referenced in the IBC or IRC.
- Embedded thread length is that portion held in the main member including the screw tip.
- Values are based on the lesser of withdrawal from the main member or pull-through of a 1½" side member.
- For in-service moisture content greater than 19%, use $C_M = 0.7$.

Load Tables, Technical Data and Installation Instructions

Strong-Drive® SDWS TIMBER Screw (cont.)

SDWS – 2009 and 2012 IRC Compliant Spacing for a Sawn Lumber Deck Ledger to Band Joist

Loading Condition	Nominal Ledger Size	Screw Model No.	Band Joist Material and Minimum Size	Maximum Deck Joist Span						
				Up to 6 ft.	Up to 8 ft.	Up to 10 ft.	Up to 12 ft.	Up to 14 ft.	Up to 16 ft.	Up to 18 ft.
				Maximum On-Center Spacing of Fasteners (in.)						
40 psf Live 10 psf Dead	2x	SDWS22400DB	1" OSB	14	10	8	7	6	5	5
			1" LVL							
			1 1/8" OSB	16	12	10	8	7	6	5
			1 5/16" LVL							
			1 1/4" LSL							
2x SP, DF – 2x SPF, HF	22	16	13	11	9	8	7			
60 psf Live 10 psf Dead	2x	SDWS22400DB	1" OSB	10	7	6	5	4	4	—
			1" LVL							
			1 1/8" OSB	12	9	7	6	5	4	4
			1 5/16" LVL							
			1 1/4" LSL							
2x SP, DF – 2x SPF, HF	15	12	9	8	7	6	5			
40 psf Live 10 psf Dead	2-2x	SDWS22500DB	1" OSB	15	12	9	8	7	6	5
			1" LVL							
			1 1/8" OSB	16	12	10	8	7	6	5
			1 5/16" LVL							
			1 1/4" LSL							
2x SP, DF – 2x SPF, HF	16	12	10	8	7	6	5			
60 psf Live 10 psf Dead	2-2x	SDWS22500DB	1" OSB	11	8	7	6	5	4	4
			1" LVL							
			1 1/8" OSB	12	9	7	6	5	4	4
			1 5/16" LVL							
			1 1/4" LSL							
2x SP, DF – 2x SPF, HF	12	9	7	6	5	4	4			

- SDWS screw spacing values are equivalent to 2009 IRC Table R502.2.2.1, and 2012 IRC Table R507.2. The table above also provides SDWS screw spacing for a wider range of materials commonly used for band joists, and an alternate loading condition as required by some jurisdictions.
- Solid-sawn band joists shall be Spruce-Pine-Fir, Hem-Fir, Douglas Fir-Larch, or Southern Pine species. Ledger shall be Hem-Fir, Douglas Fir-Larch, or Southern Pine species.
- Fastener spacings are based on the lesser of single fastener ICC-ES AC233 testing of the Strong-Drive® SDWS screw with a safety factor of 5.0 or ICC-ES AC13 ledger assembly testing with a factor of safety of 5.0. Spacing includes NDS wet service factor adjustment.
- Multiple ledger plies shall be fastened together per code independent of the SDWS screws.
- Screws shall be placed at least 1 1/2" from the top or bottom of the ledger or band joist, 6" from the end of the ledger with 3" between rows and spaced per the table. End screws shall be located near the bottom of the ledger (see figure). For end distances between 2" and 6", use 50% of the load and 50% of the table spacing between the end screw and the adjacent screw. For end distances between 2" and 4", predrill using a 5/32" drill bit.
- Structural sheathing between the ledger and band shall be a maximum of 1/2" thick and fastened per code.

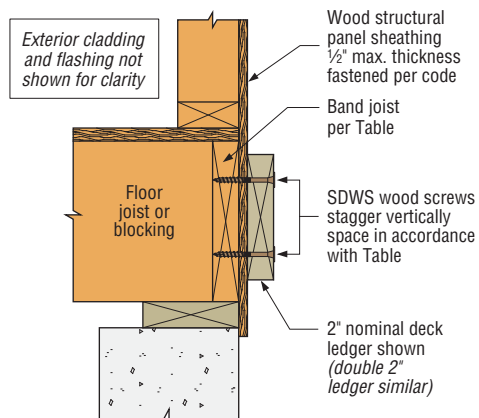

Ledger-to-Band Joist Assembly
(Wood-framed lower floor acceptable, concrete wall shown for illustration purposes)

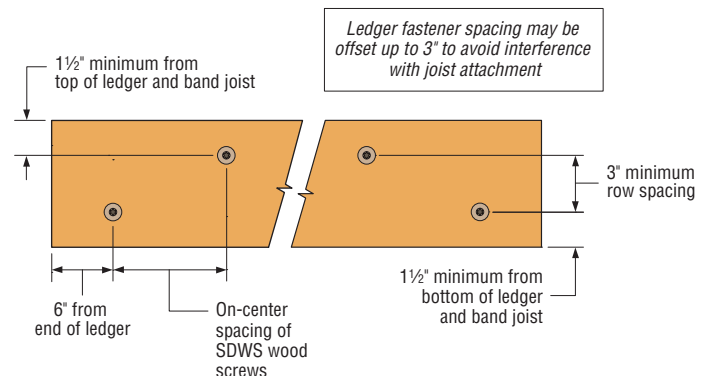

SDWS Screw Spacing Detail

C-F-14 ©2014 SIMPSON STRONG-TIE COMPANY INC.

Technical Information

Load Tables, Technical Data and Installation Instructions

Strong-Drive® SDWS TIMBER Screw (cont.)

SDWS – Allowable Shear Values for Sole-to-Rim Connections

Size (in.)	Model No.	Sole Plate Nominal Size	Minimum Penetration into Rim Board (in.)	Allowable Loads (lbs.)							
				2x DF/SP Rim Board		2x SPF/HF Rim Board		1 1/4" Min. LVL Rim Board		1 1/4" Min. LSL Rim Board	
				DF/SP Sole Plate	SPF/HF Sole Plate	DF/SP Sole Plate	SPF/HF Sole Plate	DF/SP Sole Plate	SPF/HF Sole Plate	DF/SP Sole Plate	SPF/HF Sole Plate
0.220 x 4	SDWS22400DB	2x	1.75	345	295	295	295	275	275	275	275
0.220 x 5	SDWS22500DB	2x	2	345	295	295	295	275	275	275	275
0.220 x 6	SDWS22600DB	2x or 3x	2	345	295	295	295	275	275	275	275

1. Allowable loads are based on testing per ICC-ES AC233 and are limited to parallel-to-grain loading.
2. Allowable loads are shown at the wood load duration factor of $C_D = 1.00$. Loads may be increased for load duration by the building code up to a $C_D = 1.60$.
3. Minimum spacing of the SDWS is 6" o.c., minimum end distance is 6", and minimum edge distance is 5/8".
4. Wood structural panel up to 1 1/8" thick is permitted between the sole plate and rim board provided it is fastened to the rim board per code and the minimum penetration of the screw into the rim board is met.
5. A double 2x sole plate is permitted provided it is independently fastened per the code and the minimum screw penetration per the table is met.

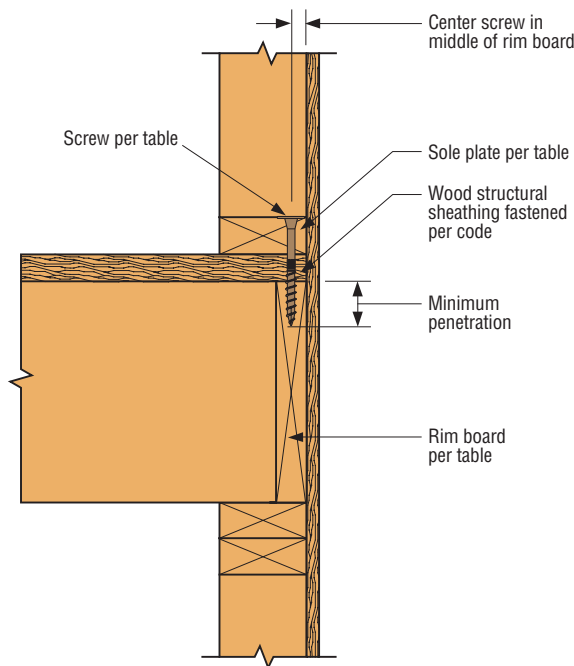

Load Tables, Technical Data and Installation Instructions

Strong-Drive® SDWS TIMBER Screw in Ledger-to-Stud Applications

The Simpson Strong-Drive® SDWS wood screws may be used to attach a ledger to the narrow face of nominal 2x lumber studs according to the following table. Tests and analyses were performed in accordance with ICC-ES Acceptance Criteria AC233.

Allowable Shear Values for Ledger Attachment to Studs

Model	Length (in.)	Ledger Size	Number of Screws per Stud	Allowable Shear Load (lbs.)		
				DF	SPF/HF	SP
SDWS22400DB	4	2x6	2	630	565	785
		2x8	3	890	855	1060
		2x10	4	1040	1040	—

1. Allowable loads shall be limited to parallel-to-grain loaded solid sawn main members (minimum 2" nominal). Wood side members shall be loaded perpendicular to grain.
2. Allowable loads are based on DF, SPF/HF, and SP wood members having a minimum specific gravity of 0.50, 0.42, and 0.55, respectively. Where the side and main members have different specific gravities, the lower values shall be used.
3. Allowable loads are shown at the wood load duration factor of $C_D = 1.00$. Loads may be increased for load duration as permitted by the building code up to a $C_D = 1.60$. All adjustment factors shall be applied per the 2012 National Design Specification (NDS). For in-service moisture content greater than 19%, use $C_M = 0.70$.
4. Fasteners shall be centered in the stud and spaced as shown in the figure. The stud minimum end distance is 6" when loaded toward the end and 2 1/2" when loaded away from the end. The ledger end distance is 6" for full values. For ledger end distances between 2" and 6" use 50% of the table loads. For end distances between 2" and 4", predrill using a 3/8" bit for SDWS.
5. Screws may be installed with an intermediate layer of wood structural panel between the side and main member provided the wood structural panel is fastened to the main member per code and the minimum screw penetration of 2 1/2" into the main member (excluding the wood structural panel) is met. Longer lengths of the screw series may be used.
6. For LRFD values, the reference connection design values shall be adjusted in accordance with the NDS, section 10.3.
7. For 2x10 SP ledgers, use the number of screws and allowable loads of the 2x8 SP ledger.
8. For 2x8 ledgers with 2 screws, use 2x6 values. For 2x10 ledgers with 3 screws, use 2x8 values. Spacings and edge distances shown in the figure are minimum dimensions.
9. For loads in the opposite direction from that shown in the figure, use the table values multiplied by: 0.50 for 2 screw connections, 0.67 for 3 screw connections, and 0.75 for 4 screw connections.

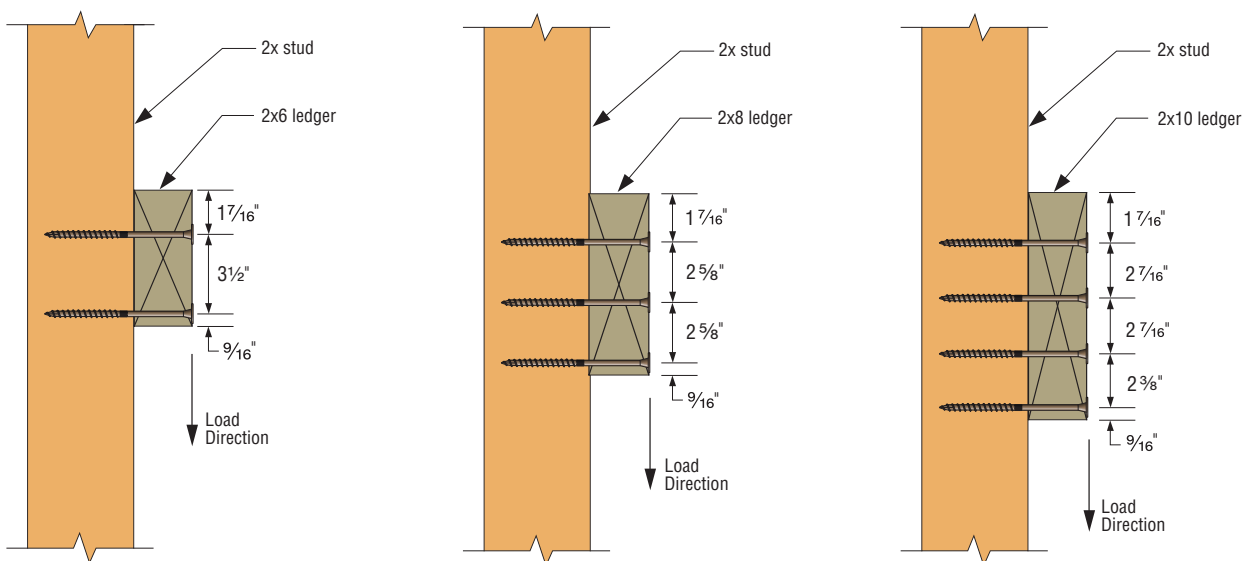

Load Tables, Technical Data and Installation Instructions

Strong-Drive® SDWS TIMBER Screw with Gypsum Board Interlayer(s)

The Strong-Drive® SDWS Timber Screw may be installed with one or two layers of 5/8" gypsum board. This layer of gypsum is to be located between the side member and main member for a standard connection and between the ledger and sheathing of a ledger connection. See the tables below for the required screw lengths and allowable loads for these applications. Loads are derived from assembly testing based on ICC-ES AC233.

SDWS – Douglas Fir-Larch and Southern Pine Lumber Allowable Single Shear Loads with ONE Layer of 5/8" Gypsum Board

Size (in.)	Model	Thread Length (in.)	DF/SP Allowable Shear Loads (lbs.)								
			Wood Side Member Thickness (in.)								
			1.5	2.0	2.5	3.0	3.5	4.0	4.5	6.0	8.0
0.22 x 4	SDWS22400DB	2.375	265	—	—	—	—	—	—	—	—
0.22 x 5	SDWS22500DB	2.75	265	265	235	—	—	—	—	—	—
0.22 x 6	SDWS22600DB	2.75	265	265	265	265	235	—	—	—	—
0.22 x 8	SDWS22800DB	2.75	265	265	265	265	255	255	255	—	—
0.22 x 10	SDWS221000DB	2.75	265	265	265	265	255	255	255	255	—

See notes on following page

SDWS – Douglas Fir-Larch and Southern Pine Lumber Allowable Single Shear Loads with TWO Layers of 5/8" Gypsum Board

Size (in.)	Model	Thread Length (in.)	DF/SP Allowable Shear Loads (lbs.)								
			Wood Side Member Thickness (in.)								
			1.5	2.0	2.5	3.0	3.5	4.0	4.5	6.0	8.0
0.22 x 4	SDWS22400DB	2.375	—	—	—	—	—	—	—	—	—
0.22 x 5	SDWS22500DB	2.75	265	265	—	—	—	—	—	—	—
0.22 x 6	SDWS22600DB	2.75	265	265	265	265	—	—	—	—	—
0.22 x 8	SDWS22800DB	2.75	265	265	265	265	255	255	255	—	—
0.22 x 10	SDWS221000DB	2.75	265	265	265	265	255	255	255	255	—

See notes on following page

SDWS – Spruce-Pine-Fir and Hem-Fir Lumber Allowable Single Shear Loads with ONE Layer of 5/8" Gypsum Board

Size (in.)	Model	Thread Length (in.)	SPF/HF Allowable Shear Loads (lbs.)								
			Wood Side Member Thickness (in.)								
			1.5	2.0	2.5	3.0	3.5	4.0	4.5	6.0	8.0
0.22 x 4	SDWS22400DB	2.375	250	—	—	—	—	—	—	—	—
0.22 x 5	SDWS22500DB	2.75	260	190	190	—	—	—	—	—	—
0.22 x 6	SDWS22600DB	2.75	260	235	235	235	200	—	—	—	—
0.22 x 8	SDWS22800DB	2.75	260	235	235	235	200	200	180	—	—
0.22 x 10	SDWS221000DB	2.75	260	235	235	235	200	200	180	180	—

See notes on following page

Load Tables, Technical Data and Installation Instructions

Strong-Drive® SDWS TIMBER Screw with Gypsum Board Interlayer(s) (cont.)

SDWS – Spruce-Pine-Fir and Hem-Fir Lumber
Allowable Single Shear Loads with TWO Layers of 5/8" Gypsum Board

Size (in.)	Model	Thread Length (in.)	SPF/HF Allowable Shear Loads (lbs.)									
			Wood Side Member Thickness (in.)									
			1.5	2.0	2.5	3.0	3.5	4.0	4.5	6.0	8.0	
0.22 x 4	SDWS22400DB	2.375	—	—	—	—	—	—	—	—	—	—
0.22 x 5	SDWS22500DB	2.75	260	190	—	—	—	—	—	—	—	—
0.22 x 6	SDWS22600DB	2.75	260	235	235	235	—	—	—	—	—	—
0.22 x 8	SDWS22800DB	2.75	260	235	235	235	200	200	180	—	—	—
0.22 x 10	SDWS221000DB	2.75	260	235	235	235	200	200	180	180	—	—

- All applications are based on full penetration (6D) into the main member.
- Allowable loads are shown at the wood load duration factor of $C_D = 1.0$. Loads may be increased for load duration per the building code up to a $C_D = 1.6$. Tabulated values must be multiplied by all applicable adjustment factors per the NDS.
- Minimum fastener spacing requirements: 6" end distance, 1 7/8" edge distance, 5/8" between staggered rows of fasteners, 4" between non-staggered rows of fasteners and 8" between fasteners in a row. See Figure 1.
- For in-service moisture content greater than 19% use $C_M = 0.7$.
- Gypsum board must be attached as required per the building code.

Load Tables, Technical Data and Installation Instructions

Strong-Drive® SDWS TIMBER Screw with Gypsum Board Interlayer(s) (cont.)

SDWS – 2009 and 2012 IRC Compliant Spacing for a Sawn Lumber Ledger to Band Joist with ONE or TWO Layers of 5/8" Gypsum Board

Loading Condition	Ledger Size	Screw Model No.	Band Joist Material and Minimum Size	Maximum Deck Joist Span						
				Up to 6 ft.	Up to 8 ft.	Up to 10 ft.	Up to 12 ft.	Up to 14 ft.	Up to 16 ft.	Up to 18 ft.
				Maximum on-center spacing of fasteners (in.)						
40 psf Live 10 psf Dead	2x	For ONE Layer of Gypsum Board use: SDWS22400DB For TWO Layers of Gypsum Board use: SDWS22500DB	1" OSB 1" LVL	13	10	8	6	6	5	4
			1 1/8" OSB 1 5/16" LVL 1 1/4" LSL	15	11	9	8	7	6	5
			2x SP, DFL 2x SPF, HF	20	15	12	10	9	8	7
60 psf Live 10 psf Dead	2x	For ONE Layer of Gypsum Board use: SDWS22400DB For TWO Layers of Gypsum Board use: SDWS22500DB	1" OSB 1" LVL	9	7	6	5	4	—	—
			1 1/8" OSB 1 5/16" LVL 1 1/4" LSL	11	8	7	5	5	4	4
			2x SP, DFL 2x SPF, HF	14	11	9	7	6	5	5
100 psf Live 10 psf Dead	2x	For ONE Layer of Gypsum Board use: SDWS22400DB For TWO Layers of Gypsum Board use: SDWS22500DB	1" OSB 1" LVL	6	4	4	—	—	—	—
			1 1/8" OSB 1 5/16" LVL 1 1/4" LSL	8	6	5	4	—	—	—
			2x SP, DFL 2x SPF, HF	9	7	5	5	4	—	—
40 psf Live 10 psf Dead	2-2x	For ONE or TWO Layers of Gypsum Board use: SDWS22600DB	1" OSB 1" LVL	14	11	9	7	6	5	5
			1 1/8" OSB 1 5/16" LVL 1 1/4" LSL	15	11	9	8	7	6	5
			2x SP, DFL 2x SPF, HF	15	11	9	8	7	6	5
60 psf Live 10 psf Dead	2-2x	For ONE or TWO Layers of Gypsum Board use: SDWS22600DB	1" OSB 1" LVL	10	8	6	5	5	4	—
			1 1/8" OSB 1 5/16" LVL 1 1/4" LSL	11	8	6	5	5	4	4
			2x SP, DFL 2x SPF, HF	11	8	6	5	5	4	4
100 psf Live 10 psf Dead	2-2x	For ONE or TWO Layers of Gypsum Board use: SDWS22600DB	1" OSB 1" LVL	7	5	4	—	—	—	—
			1 1/8" OSB 1 5/16" LVL 1 1/4" LSL	7	5	4	—	—	—	—
			2x SP, DFL 2x SPF, HF	7	5	4	—	—	—	—

- Solid-sawn band joists shall be Spruce-Pine-Fir, Hem-Fir, Douglas Fir-Larch, or Southern Pine species. Ledger shall be Hem-Fir, Douglas Fir-Larch, or Southern Pine species.
- Fastener spacings are based on the lesser of single fastener ICC-ES AC233 testing of the Strong-Drive® SDWS screw with a safety factor of 5.0 or ledger assembly testing based on ICC-ES AC13 with a factor of safety of 3.0. Spacing does NOT include NDS wet service factor adjustment.
- Multiple ledger plies shall be fastened together per code independent of the SDWS screws.
- SDWS screw spacing values are equivalent to 2009 IRC Table R502.2.2.1 and 2012 IRC Table R507.2. The table also provides SDWS screw spacing for a wider range of materials commonly used for band joists, and an alternate loading condition as required by some jurisdictions.
- Screws shall be placed at least 1 1/2" from the top or bottom of the ledger or band joist, 6 inches from the end of the ledger with 3 inches between rows and spaced per Tables 5 and 6. See figure below.
- Structural sheathing between the ledger and band shall be a maximum of 1/2 inch thick and fastened per code.
- Gypsum board must be attached as required per the building code.

Load Tables, Technical Data and Installation Instructions

Strong-Drive® SDWS TIMBER Screw with Gypsum Board Interlayer(s) (cont.)

SDWS – Allowable Shear Values for Ledger Attachment to Stud with ONE or TWO Layers of Gypsum Board

Model	Length (in.)	Ledger Size	Number of Screws per Stud	Allowable Shear Load (lbs.)		
				DF	SPF/HF	SP
SDWS22600DB	6	2x6	2	410	365	510
		2x8	3	580	555	690
		2x10	4	675	675	—

- Allowable loads shall be limited to parallel-to-grain loaded solid sawn main members (minimum 2" nominal). Wood side members shall be loaded perpendicular to grain.
- Allowable loads are based on DF, SPF/HF, and SP wood members having a minimum specific gravity of 0.50, 0.42, and 0.55, respectively. Where the side and main members have different specific gravities, the lower values shall be used.
- Allowable loads are shown at the wood load duration factor of CD = 1.00. Loads may be increased for load duration as permitted by the building code up to a CD = 1.60. All adjustment factors shall be applied per the 2012 National Design Specification (NDS). For in-service moisture content greater than 19%, use CM = 0.70.
- Fasteners shall be centered in the stud and spaced as shown in the figure. The ledger minimum end distance is 6". The stud minimum end distance is 6" when the load is toward the end and 2 1/2" when the load is away from the end.
- Screws may be installed with an intermediate layer of wood structural panel between the side and main member provided the wood structural panel is fastened to the main member per code and the minimum screw penetration of 2 1/2" into the main member (excluding the wood structural panel) is met. Longer lengths of the screw series may be used.
- For LRFD values, the reference connection design values shall be adjusted in accordance with the NDS, section 10.3.
- For 2x10 SP ledgers, use the number of screws and allowable loads of the 2x8 SP ledger.
- For 2x8 ledgers with 2 screws, use 2x6 values. For 2x10 ledgers with 3 screws, use 2x8 values. Spacings and edge distances shown in the figure are minimum dimensions.
- For loads in the opposite direction from that shown in the figure, use the table values multiplied by: 0.50 for 2 screw connections, 0.67 for 3 screw connections, and 0.75 for 4 screw connections.
- Gypsum board must be attached as required per the building code.11
- For ledger end distances between 2" and 6", use 50% of load and pre drill with 5/32" drill bit.

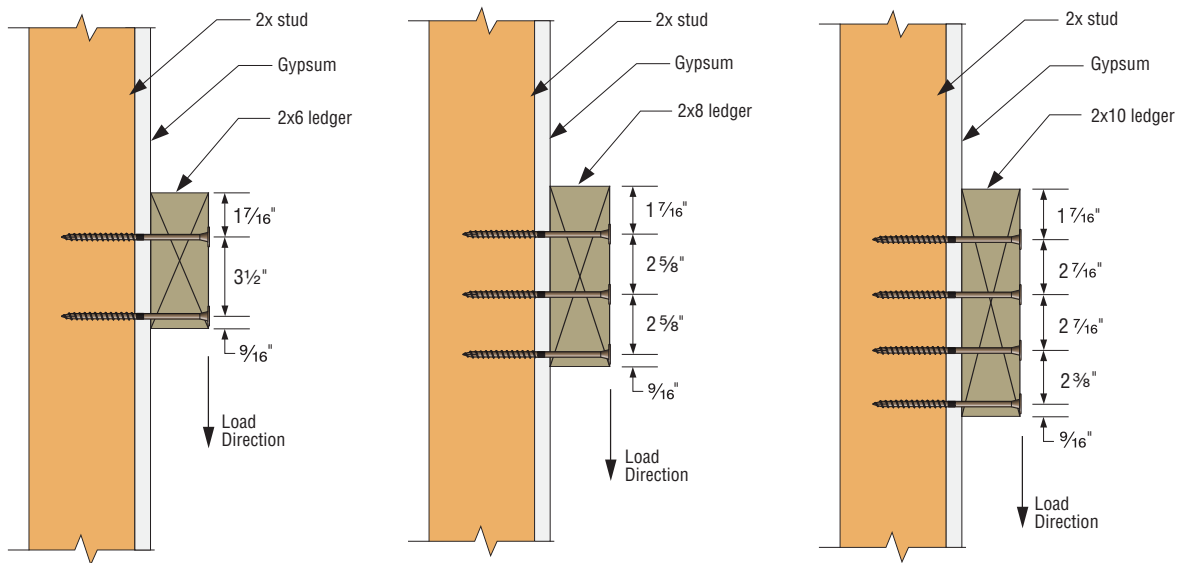

Notes to installer regarding the attachment of ledgers to studs:

The screws must be installed into the middle of the stud with a tolerance of 3/16" either side of center. Various methods can be used to ensure proper placement of the screws in the stud including snapping a chalk line, using a stud finder, or prerocking (attaching only a strip of gypsum at the ledger location until the ledger is fastened to the studs). If proper screw placement into the stud cannot be achieved in the field, blocking should be installed between studs to receive and support the ledger screws.

Load Tables, Technical Data and Installation Instructions

Strong-Drive® SDWS TIMBER Screw for Attaching Exterior Foam Insulation

Simpson Strong-Tie® Strong-Drive® SDWS Structural Wood Screws may be used for installing exterior rigid-foam board insulation over wood structural panel (WSP) sheathing. Each fastener installs through furring strips, rigid-foam board and WSP sheathing into the wood wall stud framing. The fasteners do not typically require predrilling. Preservative-treated wood suitable for dry-service (AWPA UC1, UC2, UC3A) and untreated wood may be used depending on the protection needs of the construction. The SDWS products with "DB" in the model number have a double-barrier coating that provides corrosion resistance equivalent to hot-dip galvanization, while the products without "DB" in the model number can only be used in conditions with dry-service and no wood treatment chemicals. The table on page 281 provides recommended spacing for fastening to vertical furring strips through ½" to 6" of rigid foam insulation board into each wall stud. The SDWS22DB and SDWS22 screws were evaluated as alternate threaded fasteners using ICC-ES AC233 and are the subject of IAPMO-UES ER-192. The Strong Drive SDWS22DB Structural Wood Screws were evaluated for corrosion resistance using ICC-ES AC257.

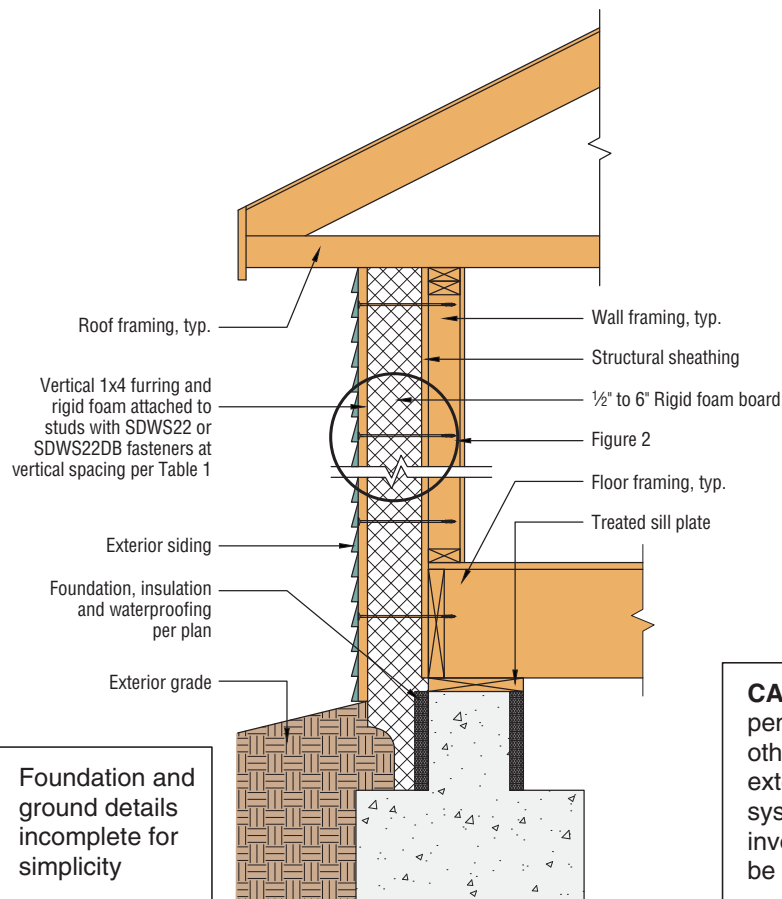

Figure 1: Wall Cross-Section

Load Tables, Technical Data and Installation Instructions

Strong-Drive® SDWS TIMBER Screw for Attaching Exterior Foam Insulation (cont.)

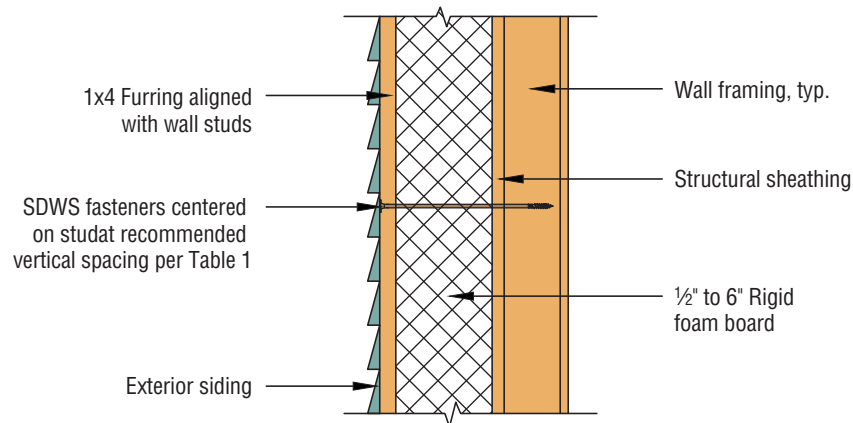

Figure 2: Furring and Rigid Foam Attachment Detail

Recommended Vertical Fastener Spacing

Model No.	Size Diameter x L (in.)	Foam Thickness (in.)	Stud Spacing (in.)	Maximum Allowable Cladding Weight to be Supported (psf)				
				≤ 20	25	30		
SDWS22400DB	0.220 x 4	½	16	24" o.c.	24" o.c.	24" o.c.		
			24					
SDWS22500DB	0.220 x 5	½ to 1¼	16					
			24					
SDWS22600DB	0.220 x 6	1½ to 2	16					
			24					
SDWS22800DB SDWS22800	0.220 x 8	2 to 4	16					
			24					
SDWS221000DB SDWS221000	0.220 x 10	4 to 6	16				18" o.c.	16" o.c.
			24					

- CAUTION: Fasteners can penetrate wiring, plumbing, and other mechanical systems in exterior walls. All mechanical systems in the exterior wall involved with the fastening shall be mapped before driving screws.
- Foam sheathing shall have a minimum compressive strength of 15 psi in accordance with ASTM C578 or ASTM C1289.
- Wood wall framing (studs) shall be a minimum of 2" nominal thickness. Wood framing and furring shall be a minimum Spruce-Pine-Fir species with specific gravity of 0.42 or greater. Table assumes furring strip thickness of ¾ in. and full thread embedment in the framing member.
- Wood framing, furring and WSP sheathing shall meet the design requirements in accordance with the applicable building codes. WSP sheathing shall be fastened to the framing as required by the applicable building code.
- Each fastener is capable of resisting 172 lbs of out of plane wind loading ($C_D = 1.60$) with no further increase allowed.
- Spacing recommendations are based on a loading that produced 0.015" of assembly movement with 6" thick rigid foam board insulation.
- Maximum allowable cladding weight shall be the additive weight of furring, cladding including foam insulation, environmental effects (i.e. ice) and other supported materials.
- Metal fasteners conduct heat, and it is recommended that exposed screw heads are covered with foam and sealed.
- Screws shall be installed such that they close gaps between connected components. Furring and sheathing shall provide the required thickness and performance for siding manufacturer installation instructions.

All other information pertaining to the use and installation of Strong-Drive® SDWS22DB and SDWS22 Structural Wood Screws is available at www.strongtie.com.

Load Tables, Technical Data and Installation Instructions

Strong-Drive® SDWS LOG Screw

Log Home Construction and General Interior Applications

Codes/Standards: IAPMO-UES ER-192

U.S. Patents: 5,897,280; 7,101,133

For More Product Information, see page 79

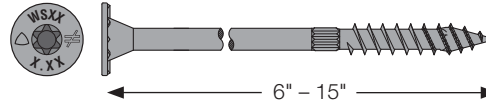

SDWS Log Allowable Shear Loads Douglas Fir-Larch and Southern Pine

Size	Model No.	Thread Length (in.)	DF/SP Allowable Shear Loads (lbs.)													
			Wood Side Member Thickness (in.)													
			1.5	2	2.5	3	3.5	4	4.5	5	5.5	6	7	8	9	10
0.195 x 6	SDWS19600	2.75	370	265	265	265	265	245	245	—	—	—	—	—	—	—
0.195 x 7.5	SDWS19712	2.75	370	265	265	265	265	245	245	245	245	—	—	—	—	—
0.220 x 8	SDWS22800	2.75	405	405	405	405	395	395	395	395	395	—	—	—	—	—
0.220 x 9	SDWS22900	2.75	405	405	405	405	395	395	395	395	395	395	—	—	—	—
0.220 x 10	SDWS221000	2.75	405	405	405	405	395	395	395	395	395	395	395	—	—	—
0.220 x 11	SDWS221100	2.75	405	405	405	405	395	395	395	395	395	395	395	395	—	—
0.220 x 12	SDWS221200	2.75	405	405	405	405	395	395	395	395	395	395	395	395	395	—
0.220 x 15	SDWS221500	2.75	405	405	405	405	395	395	395	395	395	395	395	395	395	395

SDWS Log Allowable Shear Loads Spruce-Pine-Fir and Hem-Fir SDWS

Size	Model No.	Thread Length (in.)	SPF/HF Allowable Shear Loads (lbs.)													
			Wood Side Member Thickness (in.)													
			1.5	2	2.5	3	3.5	4	4.5	5	5.5	6	7	8	9	10
0.195 x 6	SDWS19600	2.75	350	265	265	265	265	215	180	—	—	—	—	—	—	—
0.195 x 7.5	SDWS19712	2.75	350	265	265	265	265	215	215	215	215	180	—	—	—	—
0.220 x 8	SDWS22800	2.75	400	365	365	365	310	310	280	280	280	280	—	—	—	—
0.220 x 9	SDWS22900	2.75	400	365	365	365	310	310	280	280	280	280	280	—	—	—
0.220 x 10	SDWS221000	2.75	400	365	365	365	310	310	280	280	280	280	280	280	—	—
0.220 x 11	SDWS221100	2.75	400	365	365	365	310	310	280	280	280	280	280	280	—	—
0.220 x 12	SDWS221200	2.75	400	365	365	365	310	310	280	280	280	280	280	280	280	—
0.220 x 15	SDWS221500	2.75	400	365	365	365	310	310	280	280	280	280	280	280	280	280

- Design values are based on full fastener embedment and the adjacent members are in contact with each other.
- Allowable loads are shown at the wood load duration factor of $C_D = 1.0$. Loads may be increased for load duration up to a $C_D = 1.6$.
- Tabulated values must be multiplied by all applicable adjustment factors per the NDS.
- Minimum fastener spacing requirements: 6" end distance, 17/16" edge distance, 5/8" between staggered rows of fasteners, 4" between non-staggered rows of fasteners and 8" between fasteners in a row.
- For in-service moisture content less than or equal to 19%.
- Loads are based on installation into the side grain of the wood member with the screw axis perpendicular to the face of the wood member.

SDWS Log Allowable Withdrawal Loads Douglas Fir-Larch, Southern Pine, Spruce-Pine-Fir and Hem-Fir Lumber

Model No.	Fastener Length (in.)	Thread Length (in.)	Reference Withdrawal Design Value, W (lbs./in.)		Maximum Reference Withdrawal Design Value, W _{Max} (lbs.)	
			DFL and SP Main Member	HF and SPF Main Member	DFL and SP Main Member	HF and SPF Main Member
SDWS19600	6	2.75	197	164	545	395
SDWS19712	7.5	2.75	197	164	545	395
SDWS22800	8	2.75	214	187	590	495
SDWS22900	9	2.75	214	187	590	495
SDWS221000	10	2.75	214	187	590	495
SDWS221100	11	2.75	214	187	590	495
SDWS221200	12	2.75	214	187	590	495
SDWS221500	15	2.75	214	187	590	495

- The tabulated reference withdrawal design value, W, is in pounds per inch of the thread penetration into the side grain of the main member.
- The tabulated reference withdrawal design value, W_{Max}, is in pounds where the entire thread must penetrate into the side grain of the main member.
- Tabulated reference withdrawal design values ($C_D=1.0$), W and W_{Max}, must be multiplied by all applicable adjustment factors from the NDS as referenced in the IBC or IRC.
- Embedded thread length is that portion held in the main member including the screw tip.
- Values are based on the lesser of withdrawal from the main member or pull-through of a 1.5" side member.
- For in-service moisture content less than or equal to 19%.

Load Tables, Technical Data and Installation Instructions

Strong-Drive® SDWH TIMBER-HEX Screw

Structural Wood-to-Wood Connections including Ledgers

Double-barrier coating provides corrosion resistance equivalent to hot-dip galvanization, making it suitable for certain exterior and preservative-treated wood applications, as described in the evaluation report.

Codes/Standards: IAPMO-UES ER-192, State of Florida FL13975
U.S. Patents 5,897,280; 7,101,133

For More Product Information, see page 59

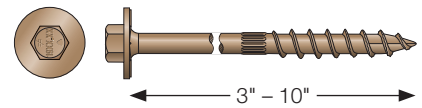

SDWH – Allowable Shear Loads – Douglas Fir-Larch and Southern Pine Lumber

Size Dia. x L (in.)	Model No.	Thread Length (in.)	DF/SP Allowable Shear Loads (lbs.)									
			Wood Side Member Thickness (in.)									
			1.5	2	2.5	3	3.5	4	4.5	6	8	
0.195 x 3	SDWH19300DB	1½	285	—	—	—	—	—	—	—	—	—
0.195 x 4	SDWH19400DB	2¾	370	300	300	—	—	—	—	—	—	—
0.195 x 6	SDWH19600DB	2¾	370	265	265	265	265	245	245	—	—	—
0.195 x 8	SDWH19800DB	2¾	370	265	265	265	265	265	260	245	—	—
0.195 x 10	SDWH191000DB	2¾	370	265	265	265	265	265	260	260	245	245

See footnotes below.

SDWH – Allowable Shear Loads – Spruce-Pine-Fir and Hem-Fir Lumber

Size Dia. x L (in.)	Model No.	Thread Length (in.)	SPF/HF Allowable Shear Loads (lbs.)									
			Wood Side Member Thickness (in.)									
			1.5	2	2.5	3	3.5	4	4.5	6	8	
0.195 x 3	SDWH19300DB	1½	230	—	—	—	—	—	—	—	—	—
0.195 x 4	SDWH19400DB	2¾	330	235	195	—	—	—	—	—	—	—
0.195 x 6	SDWH19600DB	2¾	350	265	265	265	265	215	180	—	—	—
0.195 x 8	SDWH19800DB	2¾	350	265	265	265	265	265	215	215	—	—
0.195 x 10	SDWH191000DB	2¾	350	265	265	265	265	265	250	250	215	215

- All applications are based on full penetration into the main member. Full penetration is the screw length minus the side member thickness.
- Allowable loads are shown at the wood load duration factor of $C_D = 1.0$. Loads may be increased for load duration per the building code up to a $C_D = 1.6$. Tabulated values must be multiplied by all applicable adjustment factors per the NDS.
- Minimum fastener spacing requirements to achieve table loads: 6" end distance, 1½" edge distance, 5/8" between staggered rows of fasteners, 4" between non-staggered rows of fasteners and 8" between fasteners in a row.
- For in-service moisture content greater than 19%, use $C_M = 0.7$.
- Loads are based on installation into the side grain of the wood with the screw axis perpendicular to the face of the member.

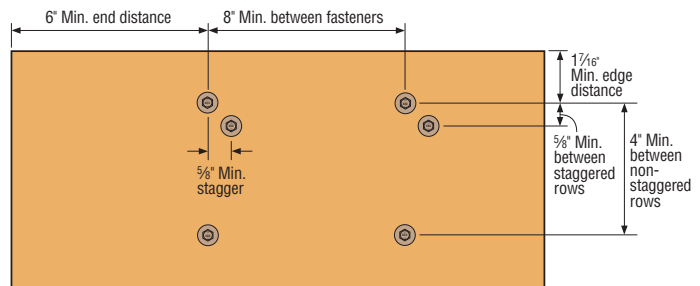

SDWH Spacing Requirements

SDWH – Allowable Withdrawal Loads – Douglas Fir-Larch, Southern Pine, Spruce-Pine-Fir and Hem-Fir Lumber

Model No.	Fastener Length (in.)	Thread Length (in.)	Reference Withdrawal Design Value, W (lbs./in.)		Max. Reference Withdrawal Design Value, W _{Max} (lbs.)	
			DF and SP Main Member	HF and SPF Main Member	DF and SP Main Member	HF and SPF Main Member
SDWH19300DB	3	1½	177	120	265	180
SDWH19400DB	4	2¾	192	147	455	350
SDWH19600DB	6	2¾	197	164	545	445
SDWH19800DB	8	2¾	197	164	545	445
SDWH191000DB	10	2¾	197	164	545	445

- The tabulated reference withdrawal design value, W, is in pounds per inch of the thread penetration into the side grain of the main member.
- The tabulated reference withdrawal design value, W_{Max}, is in pounds where the entire thread length must penetrate into the side grain of the main member.
- Tabulated reference withdrawal design values, W and W_{Max}, are shown at a $C_D = 1.0$. Loads may be increased for load duration per the building code up to a $C_D = 1.6$. Tabulated values must be multiplied by all applicable adjustment factors from the NDS as referenced in the IBC or IRC.
- Embedded thread length is that portion held in the main member including the screw tip.
- Values are based on the lesser of withdrawal from the main member or pull-through of a 1½" side member.
- For in-service moisture content greater than 19%, use $C_M = 0.7$.

Load Tables, Technical Data and Installation Instructions

Strong-Drive® SDWH TIMBER-HEX Screw (cont.)

SDWH – 2009 and 2012 IRC Compliant Spacing for
a Sawn Lumber Deck Ledger to Band Joist

Loading Condition	Nominal Ledger Size	Screw Model No.	Band Joist Material and Minimum Size	Maximum Deck Joist Span						
				Up to 6 ft.	Up to 8 ft.	Up to 10 ft.	Up to 12 ft.	Up to 14 ft.	Up to 16 ft.	Up to 18 ft.
				Maximum On-Center Spacing of Fasteners (in.)						
40 psf Live 10 psf Dead	2x	SDWH19400DB	1" OSB	13	9	8	6	5	5	4
			1" LVL							
			1½" OSB	18	13	11	9	8	7	6
			1½" LVL							
			1¼" LSL							
2x SP, DFL – 2x SPF, HF	15	12	9	8	7	6	5			
60 psf Live 10 psf Dead	2x	SDWH19400DB	1" OSB	9	7	5	5	4	—	—
			1" LVL							
			1½" OSB	13	10	8	6	5	5	4
			1½" LVL							
			1¼" LSL							
			2x SP, DFL – 2x SPF, HF	11	8	7	6	5	4	4

- SDWH screw spacing values are equivalent to 2009 IRC Table R502.2.2.1 and 2012 IRC table R507.2. The table above also provides SDWH screw spacing for a wider range of materials commonly used for band joists, and an alternate loading condition as required by some jurisdictions.
- Solid-sawn band joists shall be Spruce-Pine-Fir, Hem-Fir, Douglas Fir-Larch, or Southern Pine species. Ledger shall be Hem-Fir, Douglas Fir-Larch, or Southern Pine species.
- Fastener spacings are based on the lesser of single fastener ICC-ES AC233 testing of the Strong-Drive® SDWH screw with a safety factor of 5.0 or ICC-ES AC13 ledger assembly testing with a factor of safety of 5.0. Spacing includes NDS wet service factor adjustment.
- Screws shall be placed at least 1½" from the top or bottom of the ledger or band joist, 6" from the end of the ledger with 3" between rows and spaced per the table. End screws shall be located near the bottom of the ledger (see figure). For end distances between 2" and 6", use 50% of the load and 50% of the table spacing between the end screw and the adjacent screw. For end distances between 2" and 4", predrill using a ⅛" drill bit.
- Structural sheathing between the ledger and band shall be a maximum of ½" thick and fastened per code.

Technical Information

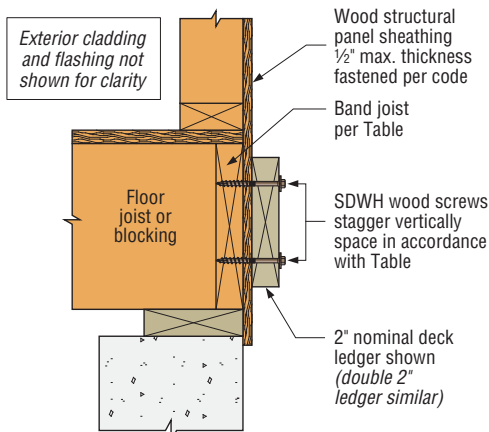

Ledger-to-Band Joist Assembly
(Wood-framed lower floor acceptable,
concrete wall shown for illustration purposes)

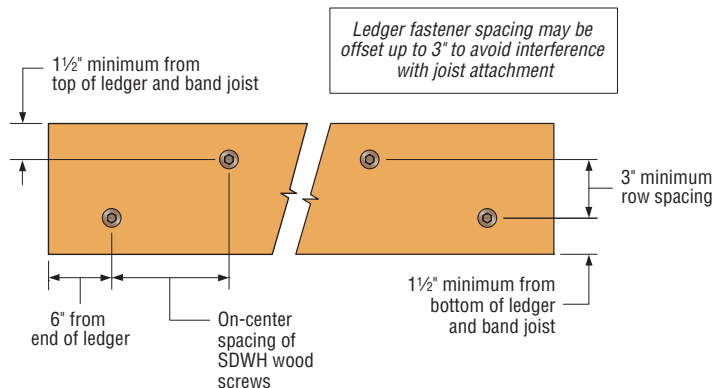

SDWH Screw Spacing Detail

Load Tables, Technical Data and Installation Instructions

Strong-Drive®

SDWH TIMBER-HEX Screw (cont.)

SDWS – Allowable Shear Values for Sole-to-Rim Connections

Size (in.)	Model No.	Sole Plate Nominal Size	Minimum Penetration into Rim Board (in.)	Allowable Loads (lbs.)							
				2x DF/SP Rim Board		2x SPF/HF Rim Board		1 1/4" Min. LVL Rim Board		1 1/4" Min. LSL Rim Board	
				DF/SP Sole Plate	SPF/HF Sole Plate	DF/SP Sole Plate	SPF/HF Sole Plate	DF/SP Sole Plate	SPF/HF Sole Plate	DF/SP Sole Plate	SPF/HF Sole Plate
0.195 x 4	SDWH19400DB	2x	1.75	315	295	295	295	255	255	275	275
0.195 x 6	SDWH19600DB	2x or 3x	2	315	295	295	295	255	255	275	275

1. Allowable loads are based on testing per ICC-ES AC233 and are limited to parallel-to-grain loading.
2. Allowable loads are shown at the wood load duration factor of $C_D = 1.00$. Loads may be increased for load duration by the building code up to a $C_D = 1.60$.
3. Minimum spacing of the SDWH is 6" o.c., minimum end distance is 6", and minimum edge distance is 5/8".
4. Wood structural panel up to 1-1/8" thick is permitted between the sole plate and rim board provided it is fastened to the rim board per code and the minimum penetration of the screw into the rim board is met.
5. A double 2x sole plate is permitted provided it is independently fastened per the code and the minimum screw penetration per the table is met.

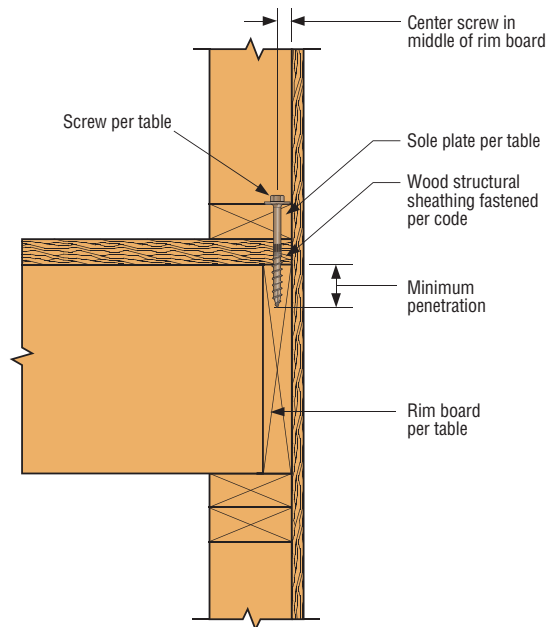

Load Tables, Technical Data and Installation Instructions

Strong-Drive® SDWH TIMBER-HEX Screw in Ledger-to-Stud Applications

The Simpson Strong-Drive® SDWH Timber-Hex wood screws may be used to attach a ledger to the narrow face of nominal 2x lumber studs according to the following table. Tests and analyses were performed in accordance with ICCES Acceptance Criteria AC233.

SDWH – Allowable Shear Values for Ledger Attachment to Studs

Model	Length (in.)	Ledger Size	Number of Screws per Stud	Allowable Shear Load (lbs.)		
				DF	SPF/HF	SP
SDWH19400DB	4	2x6	2	630	540	630
		2x8	3	815	815	630
		2x10	4	1170	975	—

- Allowable loads shall be limited to parallel-to-grain loaded solid sawn main members (minimum 2" nominal). Wood side members shall be loaded perpendicular to grain.
- Allowable loads are based on DF, SPF/HF, and SP wood members having a minimum specific gravity of 0.50, 0.42, and 0.55, respectively. Where the side and main members have different specific gravities, the lower values shall be used.
- Allowable loads are shown at the wood load duration factor of $C_D = 1.00$. Loads may be increased for load duration as permitted by the building code up to a $C_D = 1.60$. All adjustment factors shall be applied per the 2012 National Design Specification (NDS). For in-service moisture content greater than 19%, use $C_M = 0.70$.
- Fasteners shall be centered in the stud and spaced as shown in the figure. The stud minimum end distance is 6" when loaded toward the end and 2 1/2" when loaded away from the end. The ledger end distance is 6" for full values. For ledger end distanced between 2" and 6" use 50% of the table loads. For end distances between 2" and 4", predrill using a 1/8" bit for the SDWH.
- Screws may be installed with an intermediate layer of wood structural panel between the side and main member provided the wood structural panel is fastened to the main member per code and the minimum screw penetration of 2 1/2" into the main member (excluding the wood structural panel) is met. Longer lengths of the screw series may be used.
- For LRFD values, the reference connection design values shall be adjusted in accordance with the NDS, section 10.3.
- For 2x10 SP ledgers, use the number of screws and allowable loads of the 2x8 SP ledger.
- For 2x8 ledgers with 2 screws, use 2x6 values. For 2x10 ledgers with 3 screws, use 2x8 values. Spacings and edge distances shown in the figure are minimum dimensions.
- For loads in the opposite direction from that shown in the figure, use the table values multiplied by: 0.50 for 2 screw connections, 0.67 for 3 screw connections, and 0.75 for 4 screw connections.

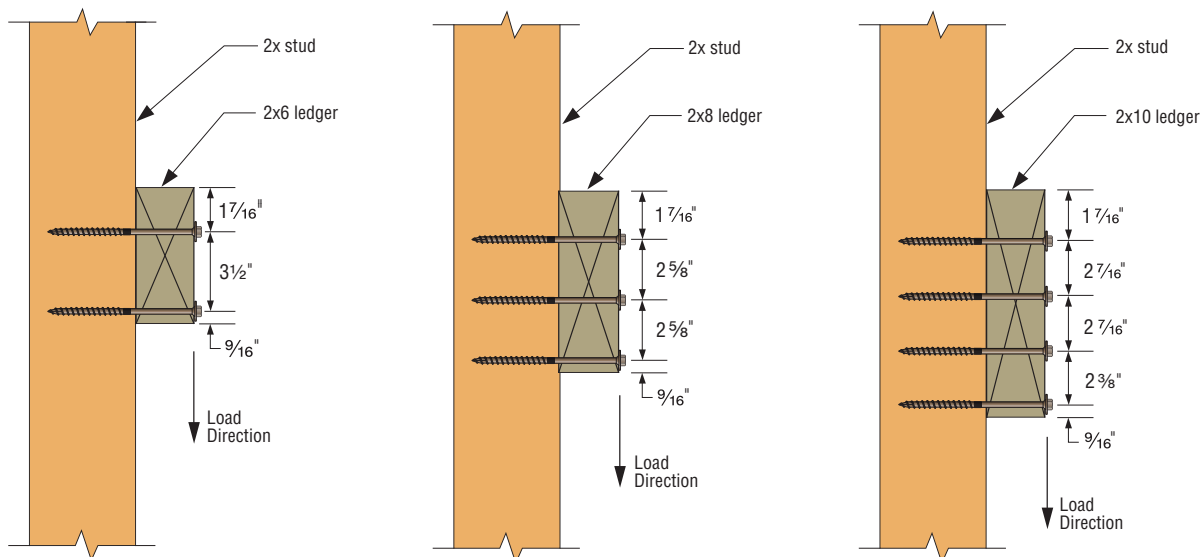

Load Tables, Technical Data and Installation Instructions

Strong-Drive® SDWH TIMBER-HEX Screw with Gypsum Board Interlayer(s)

The Strong-Drive® SDWH Timber-Hex Screw may be installed with one or two layers of 5/8" gypsum board between the wood ledger and the main member. See table for the required screw lengths and allowable loads for these applications. Loads are derived from assembly testing based on ICC-ES AC233.

SDWH – Douglas Fir-Larch and Southern Pine Lumber Allowable Single Shear Loads with ONE Layer of 5/8" Gypsum Board

Size (in.)	Model	Thread Length (in.)	DF/SP Allowable Shear Loads (lbs.)								
			Wood Side Member Thickness (in.)								
			1.5	2.0	2.5	3.0	3.5	4.0	4.5	6.0	8.0
0.19 x 4	SDWH19400DB	2.375	240	—	—	—	—	—	—	—	—
0.19 x 6	SDWH19600DB	2.75	240	170	170	170	170	—	—	—	—
0.19 x 8	SDWH19800DB	2.75	240	170	170	170	170	170	170	—	—
0.19 x 10	SDWH191000DB	2.75	240	170	170	170	170	170	170	170	—

See notes on following page

SDWH – Douglas Fir-Larch and Southern Pine Lumber Allowable Single Shear Loads with TWO Layers of 5/8" Gypsum Board

Size (in.)	Model	Thread Length (in.)	DF/SP Allowable Shear Loads (lbs.)								
			Wood Side Member Thickness (in.)								
			1.5	2.0	2.5	3.0	3.5	4.0	4.5	6.0	8.0
0.19 x 4	SDWH19400DB	2.375	—	—	—	—	—	—	—	—	—
0.19 x 6	SDWH19600DB	2.75	240	170	170	170	—	—	—	—	—
0.19 x 8	SDWH19800DB	2.75	240	170	170	170	170	170	170	—	—
0.19 x 10	SDWH191000DB	2.75	240	170	170	170	170	170	170	170	—

See notes on following page

SDWH – Spruce-Pine-Fir and Hem-Fir Lumber Allowable Single Shear Loads with ONE Layer of 5/8" Gypsum Board

Size (in.)	Model	Thread Length (in.)	SPF/HF Allowable Shear Loads (lbs.)								
			Wood Side Member Thickness (in.)								
			1.5	2.0	2.5	3.0	3.5	4.0	4.5	6.0	8.0
0.19 x 4	SDWH19400DB	2.375	215	—	—	—	—	—	—	—	—
0.19 x 6	SDWH19600DB	2.75	230	170	170	170	170	—	—	—	—
0.19 x 8	SDWH19800DB	2.75	230	170	170	170	170	170	140	—	—
0.19 x 10	SDWH191000DB	2.75	230	170	170	170	170	170	165	165	—

See notes on following page

Load Tables, Technical Data and Installation Instructions

Strong-Drive®

SDWH TIMBER-HEX Screw

with Gypsum Board Interlayer(s) (cont.)

SDWH – Spruce-Pine-Fir and Hem-Fir Lumber

Allowable Single Shear Loads with TWO Layers of 5/8" Gypsum Board

Size (in.)	Model	Thread Length	SPF/HF Allowable Shear Loads (lbs.)									
			Wood Side Member Thickness (inches)									
			1.5	2.0	2.5	3.0	3.5	4.0	4.5	6.0	8.0	
0.19 x 4	SDWH19400DB	2.375	215	—	—	—	—	—	—	—	—	—
0.19 x 6	SDWH19600DB	2.75	230	170	170	170	—	—	—	—	—	—
0.19 x 8	SDWH19800DB	2.75	230	170	170	170	170	170	140	—	—	—
0.19 x 10	SDWH191000DB	2.75	230	170	170	170	170	170	165	165	—	—

1. All applications are based on full penetration (6D) into the main member.
2. Allowable loads are shown at the wood load duration factor of $C_D = 1.0$. Loads may increase for load duration per the building code up to a $C_D = 1.6$. Tabulated values must be multiplied by all applicable adjustment factors per the NDS.
3. Minimum fastener spacing requirements: 6" end distance, 1 7/16" edge distance, 5/8" between staggered rows of fasteners, 4" between non-staggered rows of fasteners and 8" between fasteners in a row. See figure below.
4. For in-service moisture content greater than 19% use $C_M = 0.7$.
5. Gypsum board must be attached as required per the building code.

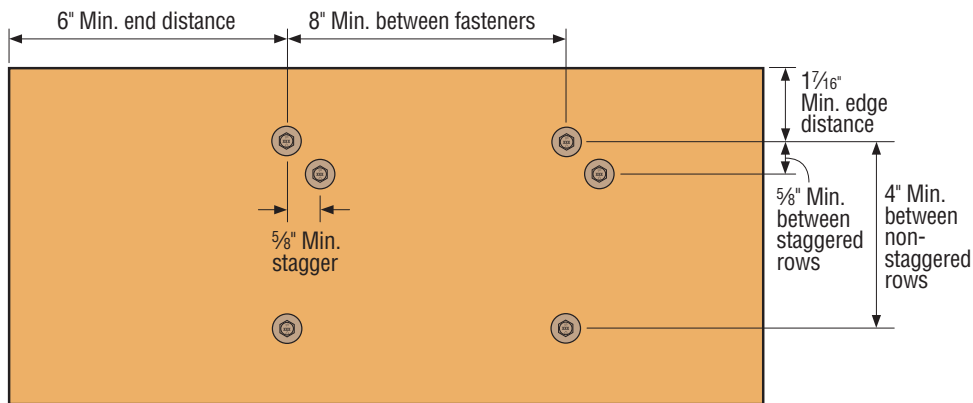

Spacing Requirements

Load Tables, Technical Data and Installation Instructions

Strong-Drive® SDWH TIMBER-HEX Screw with Gypsum Board Interlayer(s) (cont.)

SDWH – 2009 and 2012 IRC Compliant Spacing for a Sawn Lumber Ledger to Band Joist with ONE or TWO Layers of 5/8" Gypsum Board

Loading Condition	Ledger Size	Screw Model Number	Band Joist Material and Minimum Size	Maximum Deck Joist Span						
				Up to 6 ft.	Up to 8 ft.	Up to 10 ft.	Up to 12 ft.	Up to 14 ft.	Up to 16 ft.	Up to 18 ft.
				Maximum on-center spacing of fasteners (in.)						
40 psf Live 10 psf Dead	2x	For ONE Layer of Gypsum Board use: SDWH19400DB For TWO Layers of Gypsum Board use: SDWH19600DB	1" OSB 1" LVL	12	9	7	6	5	4	4
			1 1/8" OSB 1 5/16" LVL 1 1/4" LSL	17	12	10	8	7	6	6
			2x SP, DFL 2x SPF, HF	14	11	9	7	6	5	5
60 psf Live 10 psf Dead	2x	For ONE Layer of Gypsum Board use: SDWH19400DB For TWO Layers of Gypsum Board use: SDWH19600DB	1" OSB 1" LVL	8	6	5	4	4	—	—
			1 1/8" OSB 1 5/16" LVL 1 1/4" LSL	12	9	7	6	5	4	4
			2x SP, DFL 2x SPF, HF	10	8	6	5	4	4	—
100 psf Live 10 psf Dead	2x	For ONE Layer of Gypsum Board use: SDWH19400DB For TWO Layers of Gypsum Board use: SDWH19600DB	1" OSB 1" LVL	5	4	—	—	—	—	—
			1 1/8" OSB 1 5/16" LVL 1 1/4" LSL	8	6	5	4	—	—	—
			2x SP, DFL 2x SPF, HF	7	5	4	—	—	—	—

1. Solid-sawn band joists shall be Spruce-Pine-Fir, Hem-Fir, Douglas Fir-Larch, or Southern Pine species. Ledger shall be Hem-Fir, Douglas Fir-Larch, or Southern Pine species.
2. Fastener spacings are based on the lesser of single fastener ICC-ES AC233 testing of the Strong-Drive® SDWH screw with a safety factor of 5.0 or ledger assembly testing based on ICC-ES AC13 with a factor of safety of 3.0. Spacing does NOT include NDS wet service factor adjustment.
3. Multiple ledger plies shall be fastened together per code independent of the SDWH screws.
4. SDWH screw spacing values are equivalent to 2009 IRC Table R502.2.2.1 and 2012 IRC Table R507.2. The tables also provides SDWH screw spacing for a wider range of materials commonly used for band joists, and an alternate loading condition as required by some jurisdictions.
5. Screws shall be placed at least 1 1/2" from the top or bottom of the ledger or band joist, 6 inches from the end of the ledger with 3 inches between rows and spaced per the table. See figure below.
6. Structural sheathing between the ledger and band shall be a maximum of 1/2-inch thick and fastened per code.
7. Gypsum board must be attached as required per the building code.
8. For end distances between 2" and 6", use half of table spacing between end screw and adjacent screw, and pre drill with 1/8" drill bit.

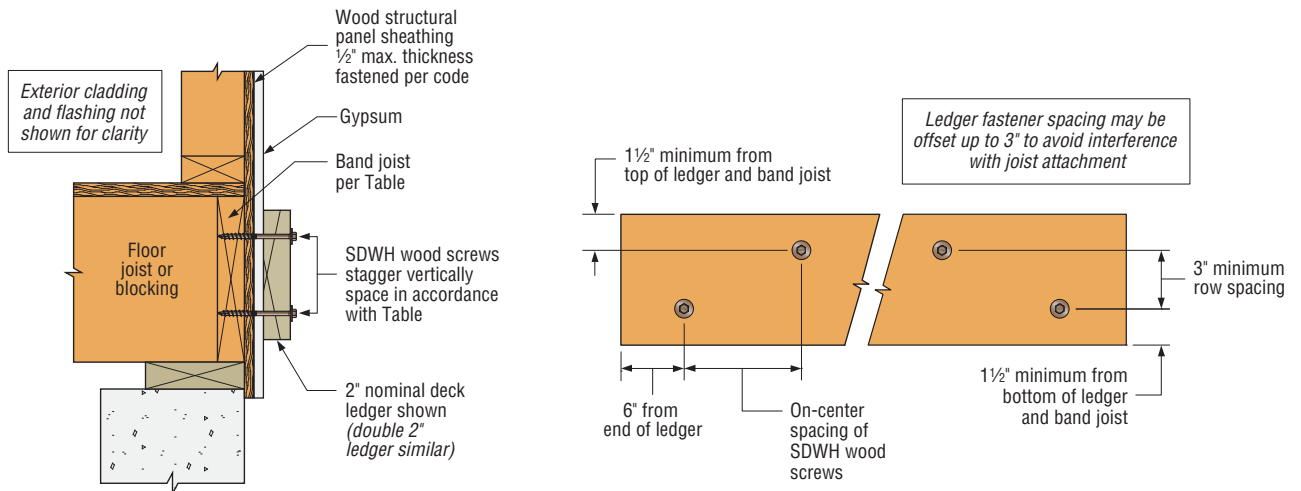

Ledger-to-Band Joist Assembly
(Wood-framed lower floor acceptable,
concrete wall shown for illustration purposes)

SDWH Screw Spacing Detail

C-F-14 © 2014 SIMPSON STRONG-TIE COMPANY INC.

Technical Information

Load Tables, Technical Data and Installation Instructions

Strong-Drive® SDWH TIMBER-HEX Screw with Gypsum Board Interlayer(s) (cont.)

Allowable Shear Values for Ledger Attachment to Studs
with ONE or TWO Layers of 5/8" Gypsum Board

Model	Length (in.)	Ledger Size	Number of Screws per Stud	Allowable Shear Load (lbs.)		
				DF	SPF/HF	SP
SDWH19600DB	6	2x6	2	410	350	410
		2x8	3	530	530	410
		2x10	4	760	635	—

- Allowable loads shall be limited to parallel-to-grain loaded solid sawn main members (minimum 2" nominal). Wood side members shall be loaded perpendicular to grain.
- Allowable loads are based on DF, SPF/HF, and SP wood members having a minimum specific gravity of 0.50, 0.42, and 0.55, respectively. Where the side and main members have different specific gravities, the lower values shall be used.
- Allowable loads are shown at the wood load duration factor of $C_D = 1.00$. Loads may be increased for load duration as permitted by the building code up to a $C_D = 1.60$. All adjustment factors shall be applied per the 2012 National Design Specification (NDS). For in-service moisture content greater than 19%, use $C_M = 0.70$.
- Fasteners shall be centered in the stud and spaced as shown in the figure. The ledger minimum end distance is 6". The stud minimum end distance is 6" when the load is toward the end and 2 1/2" when the load is away from the end. For ledger end distances between 2" and 6", use half of table loads and pre drill with 1/8" drill bit.
- Screws may be installed with an intermediate layer of wood structural panel between the side and main member provided the wood structural panel is fastened to the main member per code and the minimum screw penetration of 2 1/2" into the main member (excluding the wood structural panel) is met. Longer lengths of the screw series may be used.
- For LRFD values, the reference connection design values shall be adjusted in accordance with the NDS, section 10.3.
- For 2x10 SP ledgers, use the number of screws and allowable loads of the 2x8 SP ledger.
- For 2x8 ledgers with 2 screws, use 2x6 values. For 2x10 ledgers with 3 screws, use 2x8 values. Spacings and edge distances shown in the figure are minimum dimensions.
- For loads in the opposite direction from that shown in the figure, use the table values multiplied by: 0.50 for 2 screw connections, 0.67 for 3 screw connections, and 0.75 for 4 screw connections.
- Gypsum board must be attached as required per the building code.

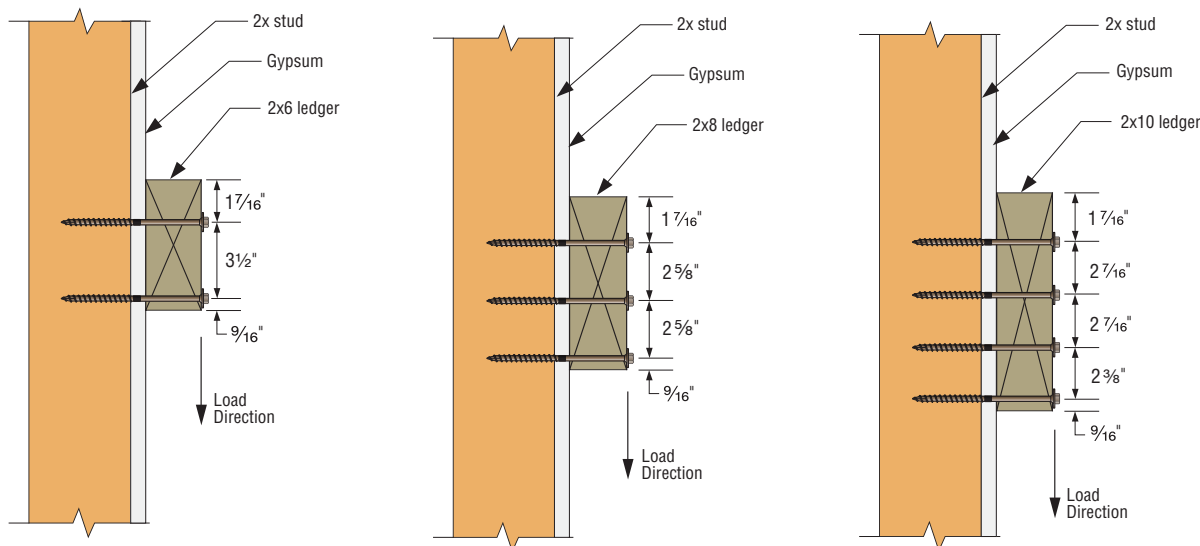

Notes to installer regarding the attachment of ledgers to studs:

The screws must be installed into the middle of the stud with a tolerance of 3/16" either side of center. Various methods can be used to ensure proper placement of the screws in the stud including snapping a chalk line, using a stud finder, or prerocking (attaching only a strip of gypsum at the ledger location until the ledger is fastened to the studs). If proper screw placement into the stud cannot be achieved in the field, blocking should be installed between studs to receive and support the ledger screws.

Load Tables, Technical Data and Installation Instructions

Strong-Drive® SDWH TIMBER-HEX SS Screw

Structural Wood-to-Wood Connections including ledger

For More Product Information, see page 60

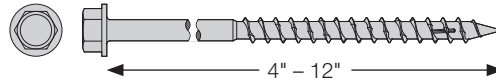

SDWH SS – Allowable Shear Loads-Douglas Fir-Larch,
Southern Pine, Spruce-Pine-Fir, Hem-Fir

Size (in.)	Model No.	Thread Length (in.)	Allowable Shear Loads (lbs.)		
			Wood Side Member Thickness (in.)		
			1½	3	3½
0.188 x 4	SDWH19400SS-R100	2.40	177	—	—
0.188 x 4½	SDWH19450SS-R100	2.75	177	177	—
0.188 x 5	SDWH19500SS-R100	2.40	177	177	177
0.188 x 6	SDWH19600SS-R100	2.40	177	177	177
0.188 x 8	SDWH19800SS-R50	2.40	177	177	177
0.276 x 4	SDWH27400SS-R100	2.95	235	—	—
0.276 x 5	SDWH27500SS-R50	2.95	235	235	235
0.276 x 6	SDWH27600SS-R50	2.95	235	235	235
0.276 x 8	SDWH27800SS-R25	2.95	235	235	235
0.276 x 10	SDWH271000SS-R25	2.95	235	235	235
0.276 x 12	SDWH271200SS-R25	2.95	235	235	235

- All applications are based on full penetration into the main member. Full penetration is the screw length minus the side member thickness.
- Allowable loads are shown at the load duration factor of $C_D = 1.0$. Loads may be increased for load duration per the building code up to a $C_D = 1.6$. Tabulated values must be multiplied by all applicable adjustment factors per the NDS.
- Table values based on testing in SPF lumber.
- Minimum fastener spacing requirements: 3" end distance, 1½" edge distance, 1½" between staggered rows of fasteners, 3" between non-staggered rows of fasteners and 3" between fasteners in a row.
- Design values include NDS wet service factor; no adjustment required for in-service moisture content greater than 19%.
- Allowable loads are perpendicular or parallel to grain.
- Installs best with 18v high-torque cordless or ½" low speed drill. If splitting occurs predrill with ⅜" drill bit for 0.188" screws and 7/8" drill bit for 0.276" screws.
- Allowable withdrawal load for the 0.188" screw for DF/SP is 155 lbs./in. and for SPF/HF is 108 lbs./in. Allowable load is based on inches of thread penetration into the main member.
- Allowable withdrawal load for the 0.276" screw for DF/SP is 260 lbs./in. and for SPF/HF is 160 lbs./in. Allowable load is based on inches of thread penetration into the main member.
- For LRFD values, the reference connection design values shall be adjusted in accordance with NDS-12, section 10.3.

Load Tables, Technical Data and Installation Instructions

Strong-Drive® SDWH TIMBER-HEX SS Screw (cont.)

SDWH SS-2009 and 2012 IRC Compliant Spacing for a Sawn Lumber Deck Ledger to Band Joist

0.188" Screws

Loading Condition	Ledger Size	Screw Length and Model No.	Band Joist Material and Size	Maximum Deck Joist Span						
				Up to 6 ft.	Up to 8 ft.	Up to 10 ft.	Up to 12 ft.	Up to 14 ft.	Up to 16 ft.	Up to 18 ft.
				Maximum On-Center Spacing of Fasteners (in.)						
40 psf Live 10 psf Dead	2x	4" SDWH19400SS	1" OSB	14	11	8	7	6	5	5
			1" LVL							
			1 1/8" OSB							
			1 5/16" LVL							
			1 1/4" OSB							
			1 1/2" LVL							
			1 1/4" LSL							
			1 3/4" LVL							
60 psf Live 10 psf Dead	2x	4" SDWH19400SS	1" OSB	10	8	6	5	4	4	3
			1" LVL							
			1 1/8" OSB							
			1 5/16" LVL							
			1 1/4" OSB							
			1 1/2" LVL							
			1 1/4" LSL							
			1 3/4" LVL							
40 psf Live 10 psf Dead	2-2x	5" SDWH19500SS	1" OSB	14	11	8	7	5	5	5
			1" LVL							
			1 1/8" OSB							
			1 5/16" LVL							
			1 1/4" OSB							
			1 1/2" LVL							
			1 1/4" LSL							
			1 3/4" LVL							
60 psf Live 10 psf Dead	2-2x	5" SDWH19500SS	1" OSB	10	8	6	5	4	4	3
			1" LVL							
			1 1/8" OSB							
			1 5/16" LVL							
			1 1/4" OSB							
			1 1/2" LVL							
			1 1/4" LSL							
			1 3/4" LVL							
40 psf Live 10 psf Dead	2-2x	5" SDWH19500SS	2x SP, DFL, SPF, HF	14	11	8	7	5	5	5
			1" OSB							
			1" LVL							
			1 1/8" OSB							
			1 5/16" LVL							
			1 1/4" OSB							
			1 1/2" LVL							
			1 1/4" LSL							
1 3/4" LVL										
60 psf Live 10 psf Dead	2-2x	5" SDWH19500SS	2x SP, DFL, SPF, HF	10	8	6	5	4	4	3
			1" OSB							
			1" LVL							
			1 1/8" OSB							
			1 5/16" LVL							
			1 1/4" OSB							
			1 1/2" LVL							
			1 1/4" LSL							
1 3/4" LVL										

- Screw spacing values are equivalent to 2009 IRC Table R502.2.2.1 and 2012 IRC Table R507.2. The table above also provides screw spacing for a wider range of materials commonly used for band joists, and an alternate loading condition as required by some jurisdictions.
- Solid-sawn band joists shall be Spruce-Pine-Fir, Hem-Fir, Douglas Fir-Larch, or Southern Pine species. Ledger shall be Hem-Fir, Douglas Fir-Larch, or Southern Pine species.
- Fastener spacings are based on the lesser of single fastener ICC-ES AC233 testing with a safety factor of 5.0 or ledger assembly testing with a factor of safety of 5.0. Spacing includes NDS wet service factor adjustment.

- Multiple ledger plies shall be fastened together per code independent of the screws.
- Screws shall be placed at least 1 7/16" from the top or bottom of the ledger or band joist 1 1/2" between staggered rows of fasteners, 3" from the end of the ledger with 3" between rows and spaced per the table.
- Structural sheathing between the ledger and band shall be a maximum of 1/2" thick and fastened per code.

Load Tables, Technical Data and Installation Instructions

Strong-Drive® SDWH TIMBER-HEX SS Screw (cont.)

SDWH SS- 2009 and 2012 IRC Compliant Spacing for a Sawn Lumber Deck Ledger to Band Joist

0.276" Screws

Loading Condition	Ledger Size	Screw Length and Model No.	Band Joist Material and Size	Max Deck Joist Span						
				Up to 6 ft.	Up to 8 ft.	Up to 10 ft.	Up to 12 ft.	Up to 14 ft.	Up to 16 ft.	Up to 18 ft.
				Max On-Center Spacing of Fasteners (in.)						
40 psf Live 10 psf Dead	2x	4" SDWH27400SS	1" OSB	19	14	11	9	8	7	6
			1" LVL							
			1 1/8" OSB							
			1 5/16" LVL							
			1 1/4" OSB							
			1 1/2" LVL							
			1 1/4" LSL							
1 3/4" LVL										
60 psf Live 10 psf Dead	2x	4" SDWH27400SS	1" OSB	13	10	8	7	6	5	4
			1" LVL							
			1 1/8" OSB							
			1 5/16" LVL							
			1 1/4" OSB							
			1 1/2" LVL							
			1 1/4" LSL							
1 3/4" LVL										
40 psf Live 10 psf Dead	2-2x	5" SDWH27500SS	1" OSB	19	14	11	9	8	7	6
			1" LVL							
			1 1/8" OSB							
			1 5/16" LVL							
			1 1/4" OSB							
			1 1/2" LVL							
			1 1/4" LSL							
1 3/4" LVL										
60 psf Live 10 psf Dead	2-2x	5" SDWH27500SS	1" OSB	13	10	8	7	6	5	4
			1" LVL							
			1 1/8" OSB							
			1 5/16" LVL							
			1 1/4" OSB							
			1 1/2" LVL							
			1 1/4" LSL							
1 3/4" LVL										
40 psf Live 10 psf Dead	2-2x	5" SDWH27500SS	1" OSB	19	14	11	9	8	7	6
			1" LVL							
			1 1/8" OSB							
			1 5/16" LVL							
			1 1/4" OSB							
			1 1/2" LVL							
			1 1/4" LSL							
1 3/4" LVL										
60 psf Live 10 psf Dead	2-2x	5" SDWH27500SS	1" OSB	13	10	8	7	6	5	4
			1" LVL							
			1 1/8" OSB							
			1 5/16" LVL							
			1 1/4" OSB							
			1 1/2" LVL							
			1 1/4" LSL							
1 3/4" LVL										
40 psf Live 10 psf Dead	2-2x	5" SDWH27500SS	1" OSB	19	14	11	9	8	7	6
			1" LVL							
			1 1/8" OSB							
			1 5/16" LVL							
			1 1/4" OSB							
			1 1/2" LVL							
			1 1/4" LSL							
1 3/4" LVL										
60 psf Live 10 psf Dead	2-2x	5" SDWH27500SS	1" OSB	13	10	8	7	6	5	4
			1" LVL							
			1 1/8" OSB							
			1 5/16" LVL							
			1 1/4" OSB							
			1 1/2" LVL							
			1 1/4" LSL							
1 3/4" LVL										
40 psf Live 10 psf Dead	2-2x	5" SDWH27500SS	1" OSB	19	14	11	9	8	7	6
			1" LVL							
			1 1/8" OSB							
			1 5/16" LVL							
			1 1/4" OSB							
			1 1/2" LVL							
			1 1/4" LSL							
1 3/4" LVL										
60 psf Live 10 psf Dead	2-2x	5" SDWH27500SS	1" OSB	13	10	8	7	6	5	4
			1" LVL							
			1 1/8" OSB							
			1 5/16" LVL							
			1 1/4" OSB							
			1 1/2" LVL							
			1 1/4" LSL							
1 3/4" LVL										

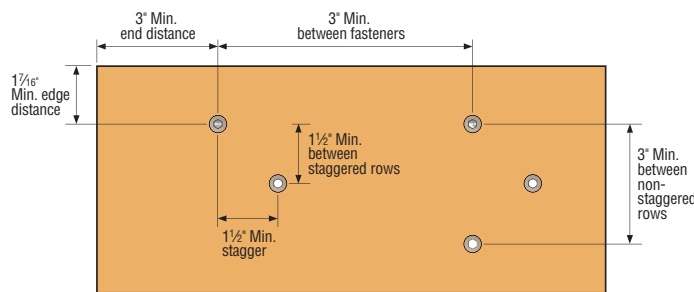

SDWH SS Screw Spacing Detail

Ledger-to-Band Joist Assembly
(Wood-framed lower floor acceptable, concrete wall shown for illustration purposes)

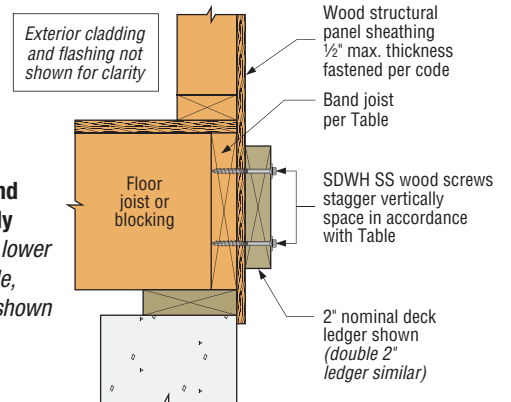

C-F-14 ©2014 SIMPSON STRONG-TIE COMPANY INC.

Technical Information

Load Tables, Technical Data and Installation Instructions

Strong-Drive® SDWC TRUSS Screw

Truss/Rafter-to-Plate and Stud-to-Plate Connections

The SDWC is tested in accordance with ICC-ES AC233 (screw) and AC13 (wall assembly and roof-to-wall assembly) for uplift and lateral loads between wall plates and vertical wall framing and between the top plate and the roof rafters or trusses. SDWC15450 is recognized for use in chemically treated wood as described in the evaluation report.

Codes/Standards: IAPMO-UES ER-262

For More Product Information, see page 77

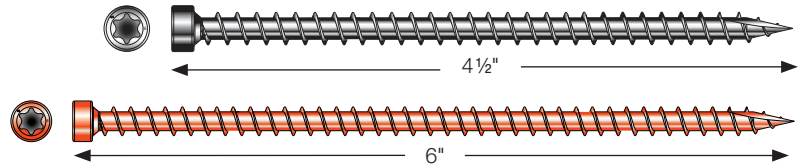

SDWC – Allowable Roof-to-Wall Connection Loads – DFL, SP, SPF, HF¹⁻⁸

Model No.	Minor Diameter (in.)	Length (in.)	Thread Length (in.)	Allowable Loads (lbs.)					
				DF/SP			SPF/HF		
				Uplift	F ₁	F ₂	Uplift	F ₁	F ₂
SDWC15600	0.152	6	5 3/4	615	130	225	485	115	192

1. Loads have been increased for wind and earthquake ($C_D=1.6$); no further increases allowed. Reduce when other loads govern.
2. Allowable loads are for an SDWC installed per the 'Recommended' or 'Optional' installation instructions. The SDWC is to be installed through a double 2x top plate into a minimum 2x4 truss or rafter.
3. An SDWC screw may be used in each ply of 2- or 3-ply rafters or trusses. The allowable uplift load for each screw shall be multiplied by 0.90, but may be limited by the capacity of the plate or the connection between the top plate to the framing below. SDWC screws in multi-ply assemblies must be spaced a minimum of 1 1/2" o.c.
4. Screws are shown installed on the interior side of the wall. Installations on the

5. For Uplift Continuous Load Path, top plate to stud connectors such as the H2.5A, TSP or MTS12 must be located on the same side of the wall as the screw.
6. When the screw is loaded simultaneously in more than one direction, the allowable load must be evaluated using the following unity equation: (Design Uplift ÷ Allowable Uplift) + (Design F₁ ÷ Allowable F₁) + (Design F₂ ÷ Allowable F₂) ≤ 1.0.
7. Table loads do not apply to trusses with end-grain bearing.
8. Top plate, stud and top plate splice fastened per applicable Building Code.

Typical Roof-to-Wall Connection

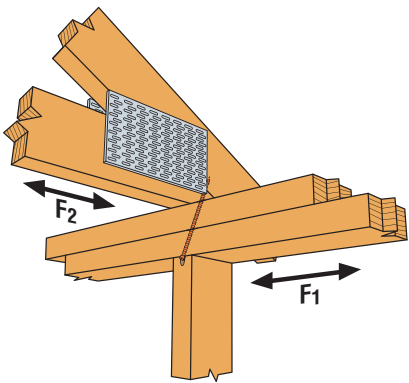

Typical SDWC Installation – Truss Aligned w/Stud (Offset truss similar)

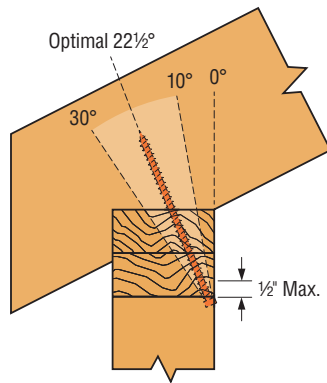

Installation Angle Limit

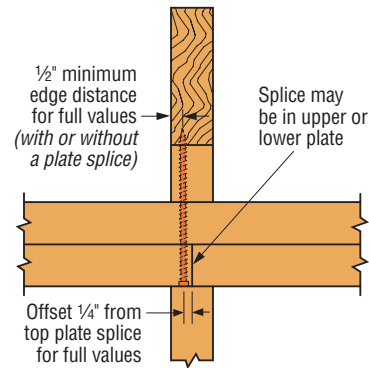

Min. Edge Distance for Top Plate Splice

Optional Roof-to-Wall Connection

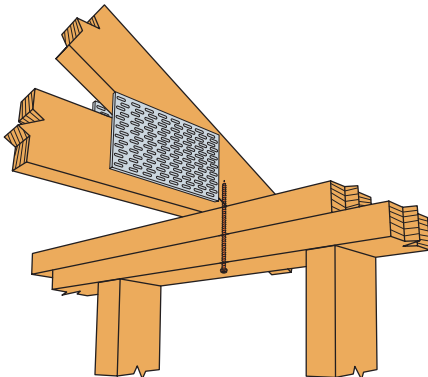

Optional SDWC Installation – Truss Offset from Stud

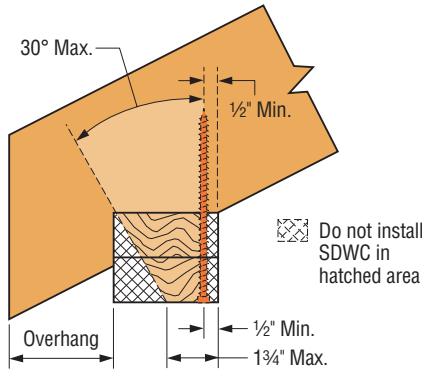

Allowable Installation Range (Truss offset from stud only)

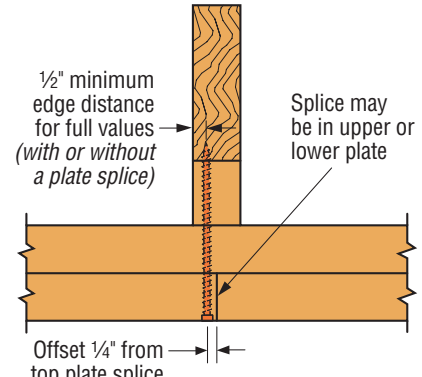

Min. Edge Distance for Top Plate Splice

Load Tables, Technical Data and Installation Instructions

Strong-Drive® SDWC TRUSS Screw (cont.)

SDWC – Allowable Stud-to-Plate Connection Loads – DFL, SP, SPF, HF¹⁻⁷

Model No.	No. of Screws Installed	Minor Diameter (in.)	Length (in.)	Thread Length (in.)	Plate Size	Allowable Loads (lbs.)			
						DF/SP		SPF/HF	
						Uplift	F ₂	Uplift	F ₂
SDWC154500	1	0.152	4½	4¼	2x	360	215	310	153
	2					690	390	595	280
	3					1035	585	895	420
SDWC15600	1	0.152	6	5¾	2x	450	189	310	153
	2					865	345	595	280
	3					1295	515	895	420
SDWC15600	1	0.152	6	5¾	(2) 2x	590	177	510	152
	2					1135	320	980	275
	3					1700	485	1470	415

1. Loads have been increased 60% for wind and earthquake loading ($C_D = 1.6$) with no further increases allowed; reduce where other loads govern.
2. Allowable loads are for SDWC installed per the installation instructions.
3. The SDWC15450 is to be installed through the face of 2x stud into a single 2x bottom plate over a concrete/masonry foundation.
4. The SDWC15600 is to be installed through the face of 2x stud into a single 2x bottom plate over a wood floor system.
5. The SDWC15600 is to be installed through the face of 2x stud into a double 2x top or bottom plate.
6. Double-top plates shall be fastened together as required by applicable code.
7. When the screw is loaded simultaneously in more than one direction, the allowable load must be evaluated using the following unity equation: $(\text{Design Uplift} \div \text{Allowable Uplift}) + (\text{Design } F_2 \div \text{Allowable } F_2) \leq 1.0$.

Stud-to-Plate Connections

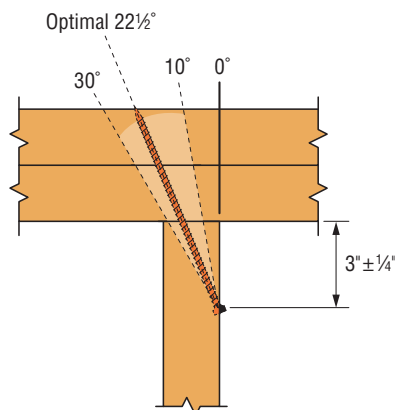

Stud-to-Top Plate Connection
(This application requires SDWC15600)

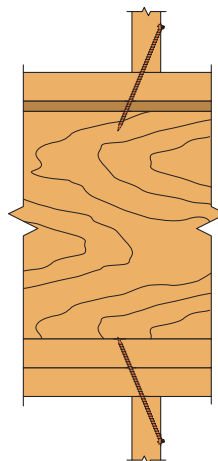

Stud-to-Bottom Plate Connection Over Wood Floor
(SDWC15600 shown)

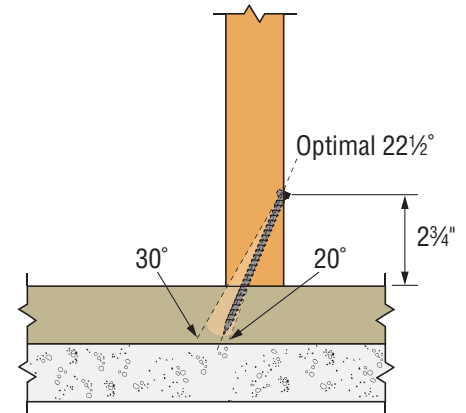

Stud-to-Bottom Plate Connection Over Concrete/Masonry Foundation
(This application requires SDWC15450)

C-F-14 ©2014 SIMPSON STRONG-TIE COMPANY INC.

Technical Information

Load Tables, Technical Data and Installation Instructions

Strong-Drive® SDWC TRUSS Screw (cont.)

SDWC – Allowable Shear Loads – DFL, SP, SPF¹⁻⁶

Model No.	Fastener Length (in.)	Thread Length (in.)	Side Member	Main Member	Allowable Shear Loads (lbs.)					
					Z _{para}			Z _{perp}		
					SP	DFL	SPF	SP	DFL	SPF
SDWC15450	4½	4¼	2x (Face)	2x (End Grain)	—	—	—	225	205	192
SDWC15600	6	5¾	(2)2x (Face)	2x (Edge)	245	240	180	240	240	240
			2x (Face)	2x (End Grain)	—	—	—	225	205	192
			(2)2x (Face)	2x (End Grain)	—	—	—	225	225	186

1. Allowable loads are shown at the wood load duration factor of $C_D = 1.0$. Loads may be increased for load duration up to a $C_D = 1.6$.
2. Tabulated values must be multiplied by all applicable adjustment factors per the NDS.
3. The main and side members shall be sawn lumber or structural composite lumber with a specific gravity or equivalent specific gravity 0.42 to 0.55.
4. Z_{para}—Parallel to grain loading in the side member and perpendicular to grain loading in the main member.
5. Z_{perp}—Perpendicular to grain loading in the side member and perpendicular to grain loading in the main member, except for 2x (edge) where main member is loaded parallel to grain
6. The connection conditions of this table are for specific intended applications. Reference lateral design values for all other shear connections are calculated following the NDS.

SDWC – Allowable Withdrawal and Pull-Through Loads – DFL, SP, SPF¹⁻³

Model No.	Screw Length (in.)	Thread Length (in.)	Main Member	Allowable Withdrawal Loads (lbs./in.)			Allowable Pull-Through Loads (lbs./in.)		
				SP	DFL	SPF	SP	DFL	SPF
SDWC15450	4½	4¼	2x (Edge)	250	230	149	—	—	—
			2x (End Grain)	200	140	103	208	179	175
SDWC15600	6	5¾	2x (Face)	210	177	118	255	195	159
			(2) 2x (Face)	220	199	163	240	225	188

1. Allowable loads are shown at the wood load duration factor of $C_D = 1.0$. Loads may be increased for load duration up to a $C_D = 1.6$.
2. Tabulated values must be multiplied by all applicable adjustment factors per the NDS.
3. The reference withdrawal and pull-through values are in pounds per inch of the thread penetration into the main member and a minimum 1½" thick side member, respectively.

Load Tables, Technical Data and Installation Instructions

Strong-Drive® SDWC TRUSS Screw for Narrow Face of Stud-to-Plate Connections

The Strong-Drive SDWC Structural Wood Screw provides an easy-to-install, high-capacity solution for stud-to-bottom plate or stud-to-top plate(s) connections. This table provides additional allowable load information for the SDWC screws when installed through the narrow face of the stud. The allowable loads are for SDWC screw installed per the details shown on page 298.

Narrow Face of Stud-to-Plate Connections¹⁻⁷

Type of Connection	Model Number	Quantity Required	Minor Diameter (in.)	Length (in.)	Thread Length (in.)	Plate Size	Allowable Loads (lbs.)			
							DF/SP		SPF/HF	
							Uplift	F2	Uplift	F2
1	SDWC15600 ¹	1	0.152	6	5 ¾	(2) 2x	590	170	510	145
2	SDWC15600 ²	1	0.152	6	5 ¾	2x	450	155	310	135
3	SDWC15450 ³	1	0.152	4 ½	4 ¼	2x	295	150	255	130

1. Loads have been increased for wind and earthquake ($C_D=1.6$), no further increase is allowed; reduce when other loads govern.
2. The SDWC15600 is to be installed through the narrow face of 2x stud into a single 2x bottom plate over a wood floor system.
3. The SDWC15450 is to be installed through the narrow face of 2x stud into a single 2x bottom plate over a concrete/masonry foundation.
4. Double-top plates shall be fastened together as required by applicable Code.
5. The F2 direction is perpendicular to the wall. When the screw is loaded simultaneously in more than one direction, the allowable load must be evaluated using the following equation: $(\text{Design Uplift} \div \text{Allowable Uplift}) + (\text{Design F2} \div \text{Allowable F2}) \leq 1.0$
6. One SDWC screw per stud maximum when installed in the narrow face of the stud. Where the SDWC screws are installed on multiple adjacent studs, the minimum spacing between screws must be 1½".
7. For uplift Continuous Load Path, connections in the same area (i.e. truss to plate connector and plate to stud connector) must be on the same side of the wall.

Load Tables, Technical Data and Installation Instructions

Strong-Drive® **SDWC TRUSS** Screw for Narrow Face of Stud-to-Plate Connections (cont.)

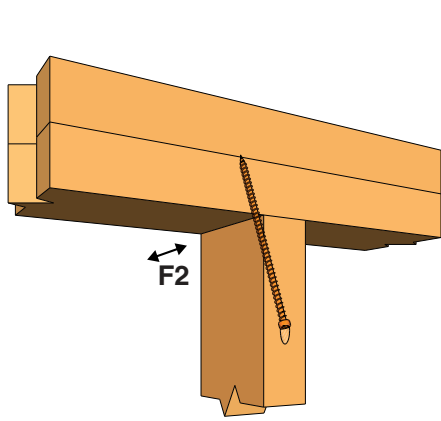

1 Narrow Face of Stud-to-Top Plate Connection
(This application requires SDWC15600)

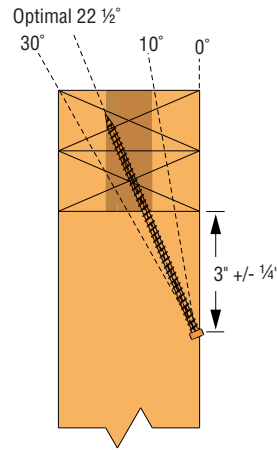

Installation Angle Range

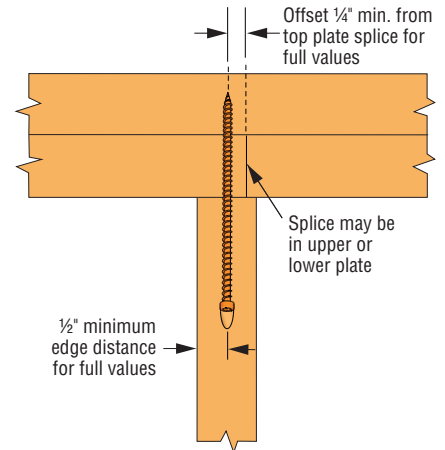

Min. Edge Distance and Splice Offset Requirements

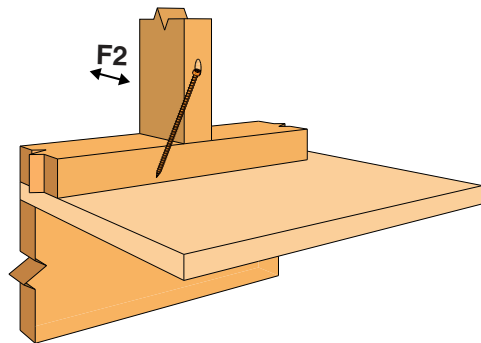

2 Narrow Face of Stud-to-Bottom Plate Connection Over Wood Floor
(SDWC15600 shown)

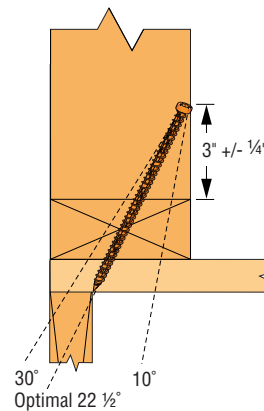

Installation Angle Range

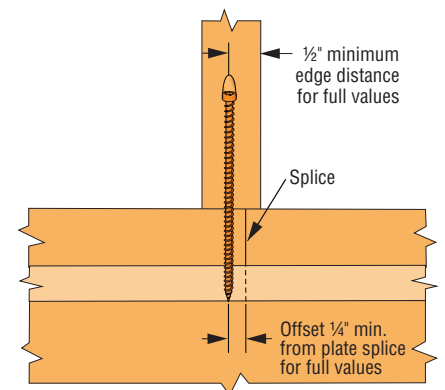

Min. Edge Distance and Splice Offset Requirements

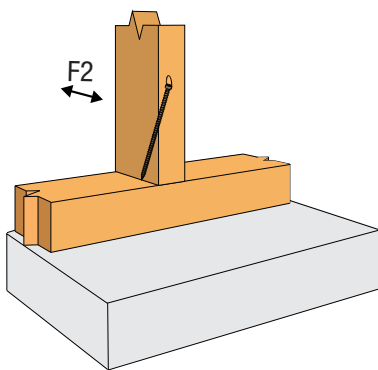

3 Narrow Face of Stud-to-Bottom Plate Connection Over Masonry/Concrete Foundation
(The application requires SDWC15450)

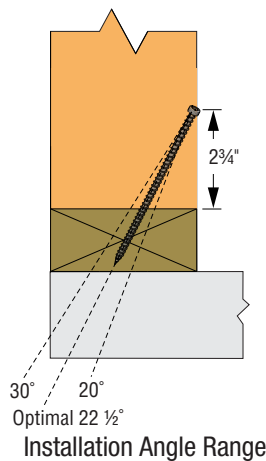

Installation Angle Range

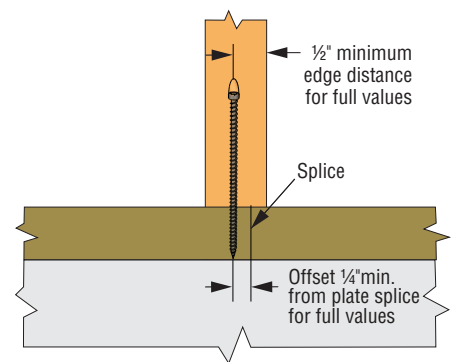

Min. Edge Distance and Splice Offset Requirements

Load Tables, Technical Data and Installation Instructions

Strong-Drive® SDWC TRUSS Screw (cont.)

Continuous Load Path Considerations with the SDWC

Building codes require structures to be designed to create a continuous load path. Forces must be transferred from their point of origin to the building elements that are designed to resist them. When uplift forces act on a roof, the roof must be tied down to the wall below it; and if the uplift forces are large enough, the wall must be tied down to the foundation or wall below.

Like many common hurricane ties, the Strong-Drive® SDWC screw fastens the rafter or truss directly to

the top plate of the wall below. The wall top plate alone does not offer sufficient resistance to roof uplift forces, and therefore must be tied to the studs or framing below. This connection may be made with structural sheathing designed for uplift or a metal connector installed on the same side of the wall as the SDWC; however, the fasteners of the sheathing or connector must not interfere with the SDWC. The Simpson Strong-Tie® H2.5A, TSP, and MTS12 are ideal metal connectors for this application.

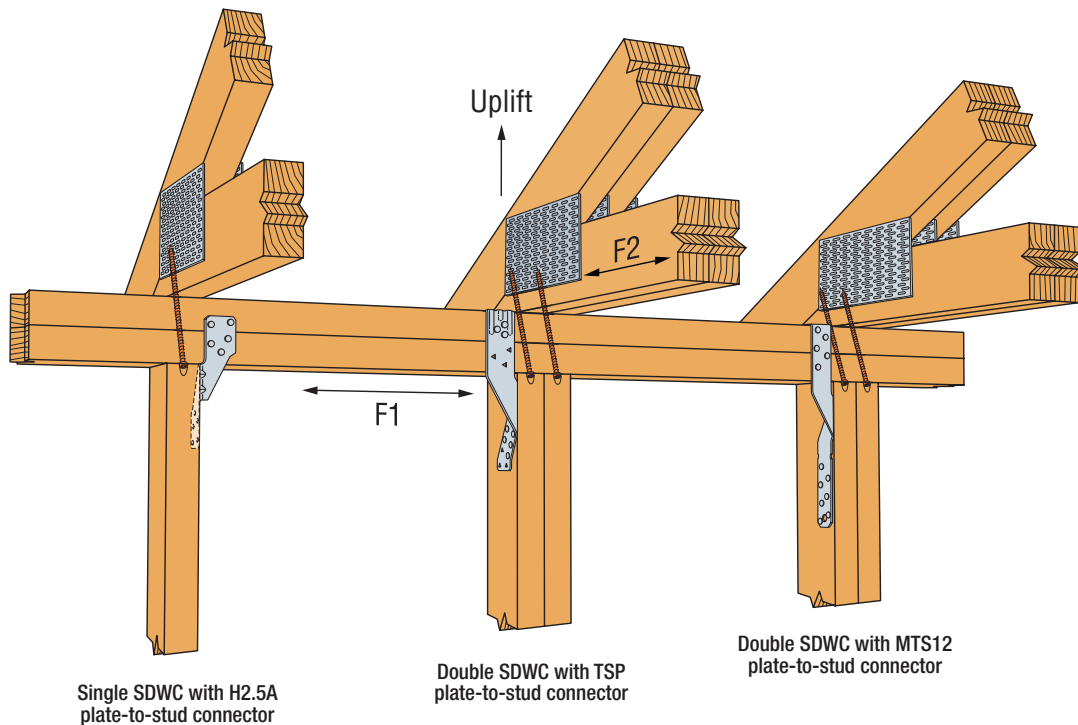

Load Tables, Technical Data and Installation Instructions

Strong-Drive® SDWC TRUSS Screw (cont.)

SDWC – Allowable Shear Values for Sole-to-Rim Connections

Size (in.)	Model No.	Sole Plate Nominal Size	Minimum Penetration into Rim Board (in.)	Allowable Loads (lbs.)							
				2x DF/SP Rim Board		2x SPF/HF Rim Board		1 1/4" Min. LVL Rim Board		1 1/4" Min. LSL Rim Board	
				DF/SP Sole Plate	SPF/HF Sole Plate	DF/SP Sole Plate	SPF/HF Sole Plate	DF/SP Sole Plate	SPF/HF Sole Plate	DF/SP Sole Plate	SPF/HF Sole Plate
0.152 x 4.5	SDWC15450	2x	2.25	235	205	205	205	—	—	—	—
0.152 x 6	SDWC15600	2x or 3x	2.25	235	205	205	205	—	—	—	—

1. Allowable loads are based on testing per ICC-ES AC233 and are limited to parallel-to-grain loading.
2. Allowable loads are shown at the wood load duration factor of $C_D = 1.00$. Loads may be increased for load duration by the building code up to a $C_D = 1.60$.
3. Minimum spacing of the SDWC is 6" o.c., minimum end distance is 6", and minimum edge distance is 5/8".
4. Wood structural panel up to 1 1/8" thick is permitted between the sole plate and rim board provided it is fastened to the rim board per code and the minimum penetration of the screw into the rim board is met.
5. A double 2x sole plate is permitted provided it is independently fastened per the code and the minimum screw penetration per the table is met.
6. The SDWC has not been evaluated with LVL or LSL rim boards.

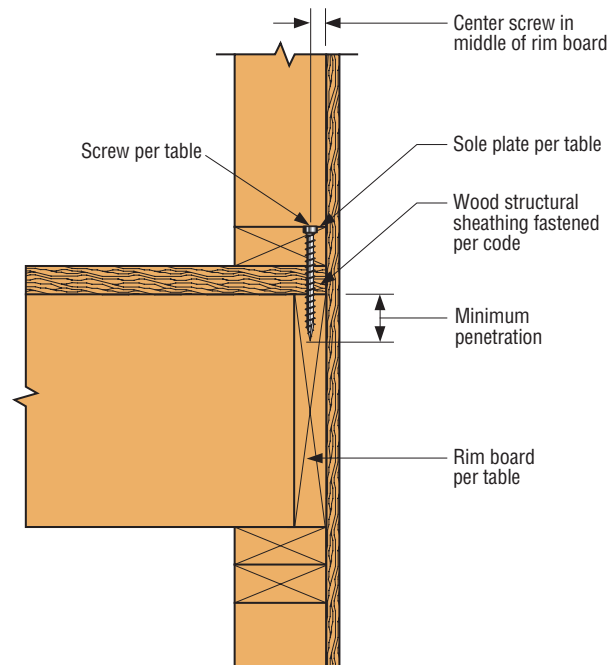

Load Tables, Technical Data and Installation Instructions

Strong-Drive® SDW TRUSS-PLY and EWP-PLY Screw

Truss-Ply Fastening, Multi-Ply Wood Members, Engineered-Lumber Products and Solid-Sawn Lumber

Codes/Standards: IAPMO-UES ER-192; City of L.A. RR25906

For More Product Information, see pages 78-79

U.S. Patents: 5,897,280; 7,101,133 and 6,109,850

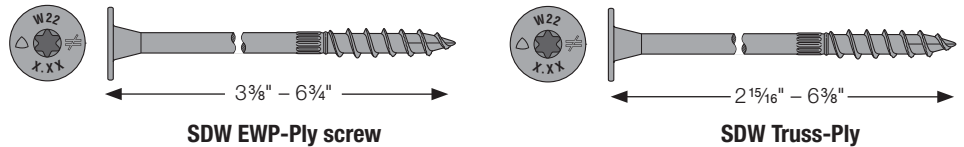

Installation:

- SDW screws install best with a low-speed 1/2" drill motor and a T-40 6-lobe bit. The matched bit included with the screws is recommended for best results.
- Pre-drilling is typically not required. SDW screws may be installed through metal truss plates as approved by the Truss Designer, provided the requirements of ANSI/TPI 1-2007 Section 8.9.2 are met (pre-drilling required through the plate using a maximum of 5/32" bit).

- Screw heads that are countersunk flush to the wood surface are acceptable if the screw has not spun out.
- Individual screw locations may be adjusted up to 3" to avoid conflicts with other hardware or to avoid lumber defects.

Notes to the Designer:

1. Single-fastener shear loads and withdrawal loads in this section, are based on testing per ICC-ES AC233. Allowable withdrawal load for DF/SP/SCL is 200 pounds per inch (lbs./in.) and for SPF/HF withdrawal is 150 lbs/in. of thread length penetration into the main member. Total allowable withdrawal load is based on actual thread penetration into the main member.
2. Allowable loads in tables are shown at the load duration factor of $C_D = 1.00$ and shall be multiplied by all applicable adjustment factors per the NDS. Loads may be increased for load duration per the building code up to a C_D of 1.6.
3. Minimum fastener spacing requirements: 6" end distance, 1 1/16" edge distance, 5/8" between staggered rows of fasteners, 4" between non-staggered rows of fasteners and 6" between fasteners in a row. Note exceptions in the application drawing at the top of page 302.
4. Maximum fastener spacing is recommended not to exceed 24" on-center except as approved by a qualified Designer.
5. Structural composite lumber (SCL = LVL, PSL or LSL) loads assume an equivalent Specific Gravity of 0.50 or higher for fastener shear in the wide face (unless otherwise noted).
6. Tabular loads in this document are based on the capacity of the Simpson Strong-Tie® SDW fasteners. The capacity of the multi-ply assembly must be checked by a qualified Designer.
7. For top loaded solid sawn 2x built-up assemblies that are evenly loaded across the entire assembly width, the recommended fastener spacing is two rows at 32" o.c.. For top-loaded SCL 1 3/4" built up assemblies that are evenly loaded across the entire assembly width, the recommended fastener spacing is two rows at 24" o.c. for up to 18" deep members, and 3 rows at 24" o.c. for members deeper than 18".

SDW Allowable Shear Loads – DF, SP, SPF, HF Lumber and 2x Truss Loaded on Head Side

Assembly	Model No.	Nominal Screw Length (in.)	Thread Length (in.)	Nominal Side Member Thickness (in.)	Main Member Penetration (in.)	DF/SP Allowable Shear (lbs.)	SPF/HF Allowable Shear (lbs.)
2-ply 2x/Truss	SDW22300	2 15/16	1 7/16	1 1/2	1 3/8 ¹	325	255
3-ply 2x/Truss Desert	SDW22438	4 3/8	1 7/16	1 1/2	2 7/8	400	325
3-ply 2x/Truss	SDW22458	4 3/8	1 7/16	1 1/2	2 7/8	400	325
4-ply 2x/Truss Desert	SDW22600	6	1 7/16	1 1/2	4 1/2	400	340
4-ply 2x/Truss	SDW22638	6 3/8	1 7/16	1 1/2	4 1/2	400	340

1. For minimum penetration into main member of 1 1/8", use 235 lbs. for DF/SP and 210 lbs. for SPF/HF.

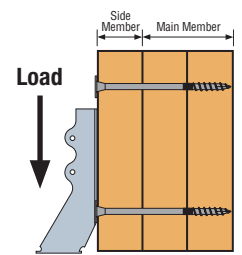

Loaded on Head Side
(3-ply assembly shown – other configurations similar)

SDW Allowable Shear Loads – DF, SP, SPF, HF Lumber and 2x Truss Loaded on Point Side

Assembly	Model No.	Nominal Screw Length (in.)	Thread Length (in.)	Nominal Side Member Thickness (in.)	Main Member Penetration (in.)	DF/SP Allowable Shear (lbs.)	SPF/HF Allowable Shear (lbs.)
2-ply 2x/Truss	SDW22300	2 15/16	1 7/16	1 1/2	1 3/8 ¹	325	255
3-ply 2x/Truss Desert	SDW22438	4 3/8	1 7/16	3	1 3/8 ¹	275	255
3-ply 2x/Truss	SDW22458	4 3/8	1 7/16	3	1 3/8 ¹	275	255
4-ply 2x/Truss Desert	SDW22600	6	1 7/16	4 1/2	1 3/8 ¹	275	255
4-ply 2x/Truss	SDW22638	6 3/8	1 7/16	4 1/2	1 3/8 ¹	275	255

1. For minimum penetration into main member of 1 1/8", use 235 lbs. for DF/SP and 210 lbs. for SPF/HF.

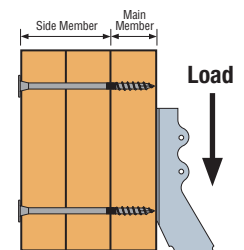

Loaded on Point Side
(3-ply assembly shown – other configurations similar)

Load Tables, Technical Data and Installation Instructions

Strong-Drive® SDW TRUSS-PLY and EWP-PLY Screw (cont.)



Lumber Fastening in Dry Climates

The highlighted regions on this map may experience drier conditions which can result in reduced lumber thickness (scant lumber) due to wood shrinkage. To help ensure optimum thread penetration into the main (last) member without excessive protrusion, Simpson Strong-Tie offers the 4 3/8" and 6" lengths of the SDW screw, which are sized for the thinner members common in these "desert" climates. It is the responsibility of the Truss Manufacturer or contractor/installer to determine the appropriate fastener length for any given application. See tables and footnotes for minimum required penetration.

SDW Allowable Shear Loads – LVL, PSL and LSL Loaded on Head Side

Assembly	Model No.	Nominal Screw Length (in.)	Thread Length (in.)	Nominal Side Member Thickness (in.)	Main Member Penetration (in.)	Equivalent Specific Gravity 0.50 Allowable Shear (lbs.)	Equivalent Specific Gravity 0.42 Allowable Shear (lbs.)
2-ply 1 3/4" SCL	SDW22338	3 3/8	1 9/16	1 3/4	1 5/8 ¹	400	255
3-ply 1 3/4" SCL	SDW22500	5	1 9/16	1 3/4	3 1/4	400	325
4-ply 1 3/4" SCL	SDW22634	6 3/4	1 9/16	1 3/4	5	400	385
2-ply 3 1/2" SCL	SDW22634	6 3/4	1 9/16	3 1/2	3 1/4	400	—

1. For minimum penetration into main member of 1 1/2", use 300 lbs.

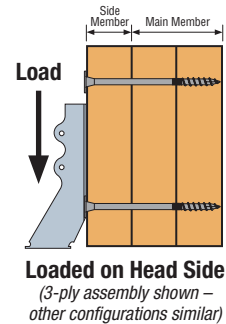

SDW Allowable Shear Loads – LVL, PSL and LSL Loaded on Point Side

Assembly	Model No.	Nominal Screw Length (in.)	Thread Length (in.)	Nominal Side Member Thickness (in.)	Main Member Penetration (in.)	Equivalent Specific Gravity 0.50 Allowable Shear (lbs.)	Equivalent Specific Gravity 0.42 Allowable Shear (lbs.)
2-ply 1 3/4" SCL	SDW22338	3 3/8	1 9/16	1 3/4	1 5/8 ¹	400	255
3-ply 1 3/4" SCL	SDW22500	5	1 9/16	3 1/2	1 1/2	300	255
4-ply 1 3/4" SCL	SDW22634	6 3/4	1 9/16	5 1/4	1 1/2	300	255
2-ply 3 1/2" SCL	SDW22634	6 3/4	1 9/16	3 1/2	3 1/4	400	—

1. For minimum penetration into main member of 1 1/2", use 300 lbs.

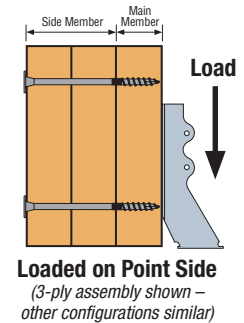

SDW Allowable Shear Loads – Two-Ply 3x2/4x2 Parallel-Chord Trusses Loaded on Either Side

Assembly	Model No.	Nominal Screw Length (in.)	DF/SP Allowable Shear (lbs.)	SPF/HF Allowable Shear (lbs.)
2-ply 3x2 PCT	SDW22500	5	280	200
2-ply 4x2 PCT	SDW22634	6 3/4	280	200

- To transfer uniform or concentrated loads applied to simply supported spans on assembly top chord:
 - Space screws as required to transfer half the load into the supporting truss.
 - Minimum screw spacing shall be 4" o.c.
- To transfer concentrated loads applied to simply supported spans on an assembly top chord or vertical web:
 - Concentrated loads must be applied at a panel point.
 - Screws to be installed within 12" of the concentrated load on top-chord assembly
- Gap between the trusses shall not exceed 1/8".
- Floor sheathing shall be screwed or nailed to each top-chord ply. (Fastener spacing per the applicable Code requirements, or 12" o.c.)
- SDW screws shall not be installed in areas where lumber wane exceeds 1/4".
- Hangers on skewed girders:
 - Hanger loads not exceeding 34" o.c. on a skewed girder (resulting from uniformly spaced joists up to 24" o.c.) may be converted to a uniform load.
 - For girders with hanger load spacing in excess of 34" o.c. the loads shall be considered as concentrated loads at the applicable locations.
- Other configurations acceptable as long as approved by Truss Designer.

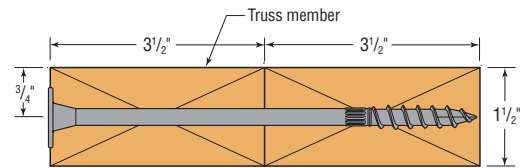

SDW Screw Position in 2-Ply 4x2 Truss
(2-ply 3x2 similar)

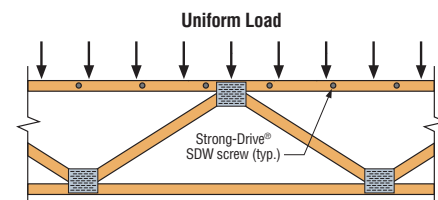
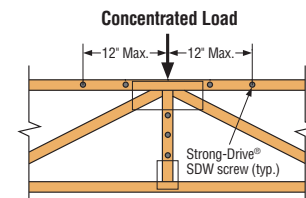

Load Tables, Technical Data and Installation Instructions

Strong-Drive® SDW TRUSS-PLY and EWP-PLY Screw (cont.)

SDW – Allowable Uniform Load Applied to Either Outside Member – Side-loaded Multi-Ply Assemblies

Multiple Members		Nominal Screw Length (in.)	Loaded Side	DF/SP						SPF/HF					
				12" o.c.		16" o.c.		24" o.c.		12" o.c.		16" o.c.		24" o.c.	
Assembly	Components			2 Rows	3 Rows	2 Rows	3 Rows	2 Rows	3 Rows	2 Rows	3 Rows	2 Rows	3 Rows	2 Rows	3 Rows
A-W	2-ply 2x/Truss	2 1/16"	Either	1300	1950	975	1465	650	975	1020	1530	765	1150	510	765
B-W	3-ply 2x/Truss	4 3/8" or 4 5/8"	Head	1200	1800	900	1350	600	900	975	1465	730	1095	490	730
			Point	825	1240	620	930	415	620	765	1150	575	860	385	575
C-W	4-ply 2x/Truss	6 or 6 3/4"	Head	1065	1600	800	1200	535	800	905	1360	680	1020	455	680
			Point	735	1100	550	825	365	550	680	1020	510	765	340	510

- Each ply is assumed to carry same proportion of load.
- Loads may be applied to the head side and point side concurrently provided neither published allowable load is exceeded. (Example: a 3-ply DF assembly with a head side load of 1300 plf and point side load of 900 plf may be fastened together with 3 rows of SDW at 16" o.c.)
- When hangers are installed on point side, hanger face fasteners must be a minimum of 3" long.
- Tables are based on Main Member Penetration as noted in Tables 1 and 2.
- Hanger load spacing on the multi-ply assembly should not exceed 24" o.c. Exception: On a skewed girder, hanger loads up to 34" o.c. (resulting from joists uniformly spaced up to 24" o.c.) may be converted to a uniform load.

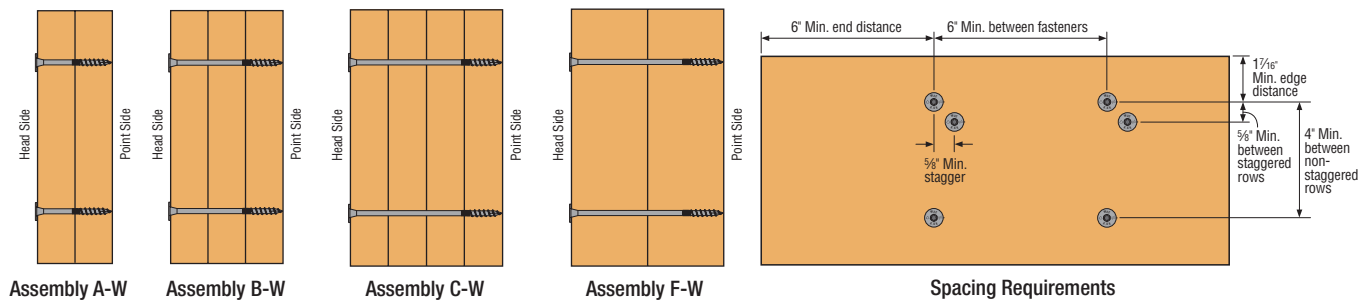

SDW – Allowable Uniform Load Applied to Either Outside Member – Side-loaded Multi-Ply LVL, PSL, and LSL Assemblies

Multiple Members		Nominal Screw Length (in.)	Loaded Side	12" o.c.		16" o.c.		24" o.c.	
Assembly	Components			2 Rows	3 Rows	2 Rows	3 Rows	2 Rows	3 Rows
A-W	2-ply SCL	3 3/8"	Either	1600	2400	1200	1800	800	1200
B-W	3-ply SCL	5"	Head	1200	1800	900	1350	600	900
			Point	900	1350	675	1015	450	675
C-W	4-ply SCL	6 3/4"	Head	1065	1600	800	1200	535	800
			Point	800	1200	600	900	400	600
F-W	2-ply 3 1/2" SCL	6 3/4"	Either	1600	2400	1200	1800	800	1200

- Each ply is assumed to carry same proportion of load.
- Loads may be applied to the head side and point side concurrently provided neither published allowable load is exceeded. (Example: a 3-ply assembly with a head side load of 1300 plf and point side load of 1000 plf may be fastened together with 3 rows of SDW @ 16" o.c.)
- When hangers are installed on point side, hanger face fasteners must be a minimum of 3" long.
- Tables are based on Main Member Penetration as noted in single-fastener load tables.

Load Tables, Technical Data and Installation Instructions

Strong-Drive® SDWF FLOOR-TO-FLOOR Screw

Wind-Uplift Restraint Connections

Features:

- Shrinkage compensation ensures a tight connection even after initial shrinkage and settlement occur
- One screw length can be used for multiple floor depths (refer to chart to select appropriate screw size), reducing the need for many screw lengths

Codes/Standards: ICC-ES ESR-3046 (SDWF), ICC-ES ESR-2320 (TUW)

For more information, see page 80

U.S. Patent: 8,276,323

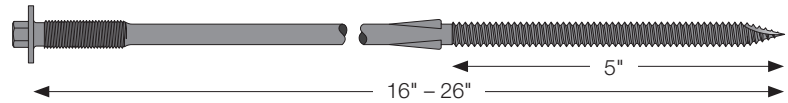

Additional Installation Considerations:

- To choose the appropriate SDWF screw length, see top table on next page
- The SDWF installs best with a high torque, ½" variable speed drill (at least 18V if cordless) with a 5/16" hex-head driver (hex driver provided)
- See details for minimum edge/end fastener distances

Installation Instructions for the Strong-Drive SDWF STRUCTURAL Screw and Take-Up Washer (TUW)

To Install:

- a) Drive the SDWF screw vertically ($90^{\circ} \pm 2^{\circ}$) into the center of the upper-wall bottom plate.
 - b) Once SDWF has passed through upper-wall bottom plate and floor sheathing, make sure SDWF is still vertical ($90^{\circ} \pm 2^{\circ}$) prior to driving SDWF into lower-wall double top plate. Adjust if necessary.
 - c) Continue driving SDWF until the head is a minimum of 2" above the upper-wall bottom plate.
2. Slide the TUW (provided) over the SDWF screw head and center using locator tab as a reference. Orient locator tab so that it points toward the outside of the wall.



1.a



1.b



1.c



2

3. Secure the TUW to the upper-wall bottom plate with (4) #9 x 2 ½" Simpson Strong-Tie® Strong-Drive SD screws (provided).
4. Continue driving the SDWF screw until the washer head contacts the threaded TUW tabs and bends them until they engage the shank of the SDWF directly under the head. Do not overdrive!
5. Check to ensure the proper engagement of the TUW tabs to the SDWF screw shank using the screw depth guide (provided). The measured gap shall be no greater than 3/32" and no less than 5/32".



3



4



5

Load Tables, Technical Data and Installation Instructions

Strong-Drive®

SDWF FLOOR-TO-FLOOR Screw Installation Conditions

Product Information and Withdrawal Loads

Model No	Size (in.)	Thread Length (in.)	Allowable Joist Depth Below (in.)				Allowable Withdrawal per Thread Penetration (lbs./in.)		
			Single Bottom Plate		Double Bottom Plate		SP	DF	SPF
			Min.	Max.	Min.	Max.			
SDWF2716-TUW	0.27 x 16	5	8½	10½	6¾	9	295	250	180
SDWF2720-TUW	0.27 x 20	5	12½	14½	10¾	13			
SDWF2724-TUW	0.27 x 24	5	16½	18½	14¾	17			
SDWF2726-TUW	0.27 x 26	5	18½	20½	16¾	19			

1. Allowable loads are for $C_D=1.0$ and may be increased for load duration up to $C_D = 1.6$.
2. Joist depth listed based on the ¾" subfloor and 3" of thread penetration into double top plates

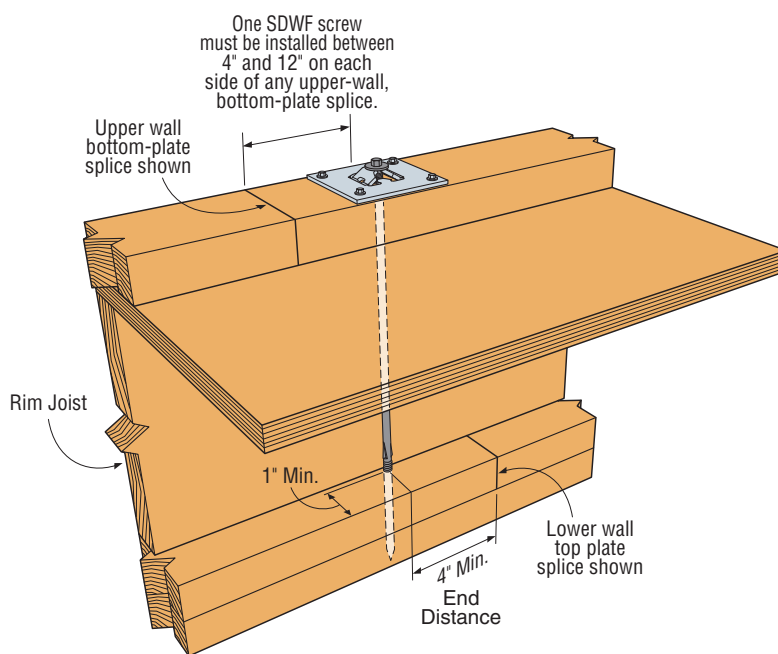

Typical SDWF and TUW Installation

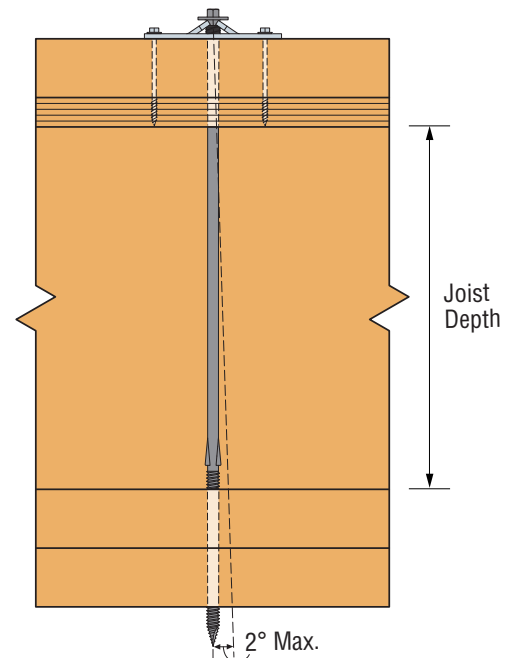

Typical SDWF Angle Limit Installation

Uniform Uplift Loads

Maximum SDWF Screw Spacing (in.) Along Wall Bottom Plate for Wind Uplift											
Bottom Plate	Interstory Unit Wind Uplift, Lbs. Per Lineal Foot (plf)										
	100 plf	150 plf	200 plf	250 plf	300 plf	350 plf	400 plf	450 plf	500 plf	550 plf	600 plf
Single 2x4											
SP	46	40	36	34	30	28	26	24	24	22	22
DF	48	42	38	34	32	30	30	26	24	22	20
SPF	46	40	36	34	32	30	26	22	20	18	16
Single 2x6											
SP	56	48	44	40	38	36	34	34	32	30	28
DF	56	48	44	40	38	34	30	26	24	22	20
SPF	52	46	42	38	34	30	26	22	20	18	16

1. Spacing listed based on lesser of: single bottom plate bending allowable load, single bottom plate deflection limited to spacing/240 and ¼" max, screw allowable withdrawal load, and take-up washer allowable load.
2. Withdrawal load is based on a $C_D = 1.6$ and minimum 3" penetration into lower wall double top plates.
3. Stud-to-plate connections are required to complete the load path. These connections shall not exceed the lesser of 48" o.c. or SDWF spacing
4. Spacing values listed for SP lumber consider new base values adopted by AWC on June 1, 2012.

Load Tables, Technical Data and Installation Instructions

Strong-Drive® SDWF FLOOR-TO-FLOOR Screw Installation Conditions

Concentrated Uplift Loads

Model No	Single SDWF-TUW				Double SDWF-TUW			
	Allowable Tension Load (lbs.)			Deflection at Highest Allowable Load (in.)	Allowable Tension Load (lbs.)			Deflection at Highest Allowable Load (in.)
	SP	DF	SPF		SP	DF	SPF	
SDWF2716-TUW	1410	1200	865	0.095	2270	2125	1730	0.142
SDWF2720-TUW								
SDWF2724-TUW								
SDWF2726-TUW								

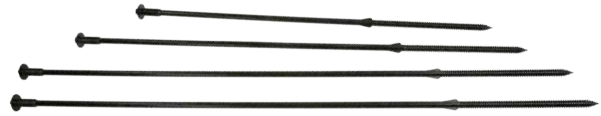

1. Allowable loads listed include a wood load duration factor of $C_D = 1.6$ for wind or earthquake loading with no further increase allowed; reduce when other loads govern.
2. Single and double SDWF-TUW applications listed are for concentrated load uplift restraint conditions (i.e. end of header, at girders, or at the end of shearwalls).

Note: Stud-to-plate connections are required to complete the load path and are the responsibility of the Designer.

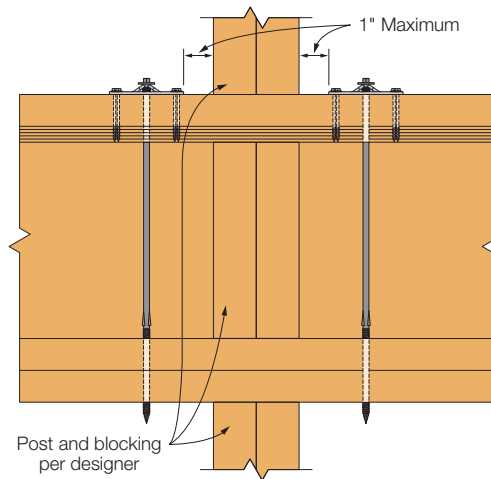

Double SDWF-TUW concentrated load restraint detail at continuous wall
(Single SDWF-TUW similar)

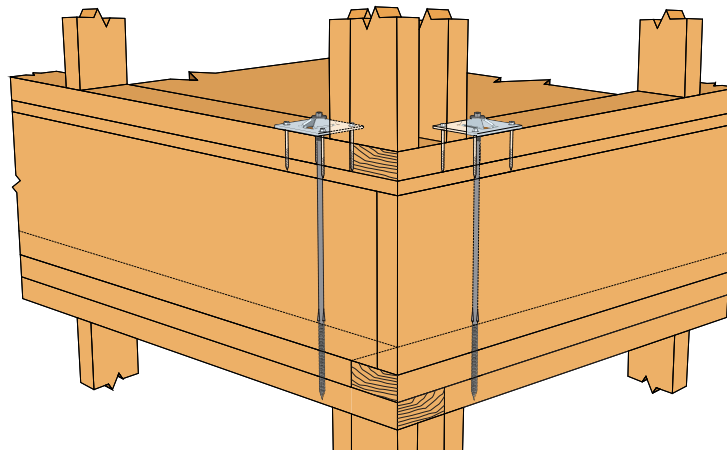

Perspective view of corner conditions with double SDWF-TUW
(Single SDWF-TUW similar)

Technical Information



Web App Enables Designers to Calculate Wood Shrinkage Easier

The Simpson Strong-Tie Wood Shrinkage Calculator is a quick and easy Web App to estimate the amount of shrinkage the structure may experience as the wood member loses moisture content after it is framed and in service. The calculator estimates the shrinkage of each wood member in the wall and floor framing assembly and provides a graphical summary to help understand the global impact of shrinkage of individual elements in the wall system. To access this free application, visit www.strongtie.com/shrinkcalc.

Load Tables, Technical Data and Installation Instructions

Strong-Drive® TB WOOD-TO-STEEL Screw

Common Applications:

- Wood to hot-rolled steel (Maximum recommended thicknesses: 5/16")

For More Product Information, see page 194

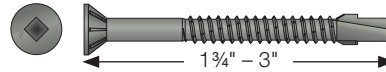

TB – Allowable Loads – DF and SP Lumber Attachment to Steel (Steel Members 16 ga - 5/16" Thick)

Model No.	Length in. (mm)	Nominal Wood Thickness	Steel Thickness mil (ga)	DF/SP Allowable Load (lbs.)			
				Uplift		Shear	
				C ₀ =1.0	C ₀ =1.6	C ₀ =1.0	C ₀ =1.6
TB1460S	2 3/8" (60)	2x	54 (16)	195	195	210	335
			68 (14)	225	225	210	335
			97-312 (12 - 5/16")	245	390	215	345
TB1475S	3" (75)		54 (16)	195	195	210	335
			68 (14)	225	225	210	335
			97-312 (12 - 5/16")	245	390	215	345

1. For use with structural steel members up to 5/16" thick or cold-formed steel members 54 mil (16 ga.) or thicker.
2. Standard product available in a black phosphate, yellow zinc or N2000 coating for additional corrosion protection (TBG1460S or TBG1475S).
3. For use with 2x (1 1/2") DF/SP only.
4. For use with QD HSD60 or HSD75 Tool.
5. Use increased allowable loads (C₀=1.6) only when resisting wind or seismic forces.

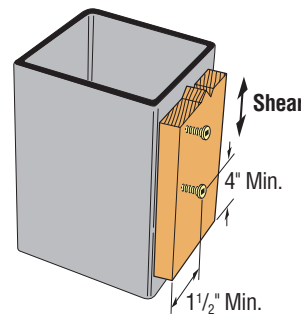
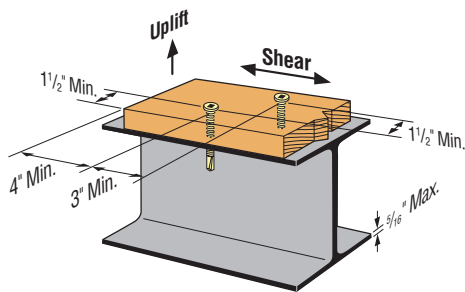

Load Tables, Technical Data and Installation Instructions

Strong-Drive® WSNTL SUBFLOOR Screw

For Subfloor and Sheathing to wood, Multi-Ply Wood Members

Codes/Standards: ICC-ES ESR-1472; City of L.A. RR25661; Florida FL 13731 (Note: 1¾" length not code listed)

For More Product Information, see pages 188-189

WSNTL – Allowable Shear – Wood Structural Panel Diaphragms with Framing of Douglas Fir-Larch or Southern Pine for Wind or Seismic Loading (2", 2½" and 3" Lengths) (in Pounds per Foot)¹⁻⁸

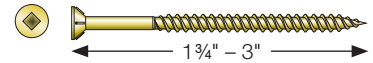

Panel Grade	Minimum Nominal Panel Thickness (in.)	Minimum Nominal Width of Framing Members at Adjoining Panel Edges and Boundaries (in.) ^{4,5}	Blocked Diaphragms				Unblocked Diaphragms	
			Screw spacing (inches) at diaphragm boundaries (all cases), at continuous panel edges parallel to load (Cases 3 and 4), and at all edges (Cases 5 and 6) ⁶				Screws spaced 6", maximum, at support edges ⁶	
			6	4	2½	27	Case 1 (no unblocked edges or continuous joints parallel to load)	All other configurations (Cases 2,3,4,5 and 6)
			Screw Spacing (in.) at Other Panel Edges					
6	6	4	3					
Structural 1/OSB	¾	2	270	360	530	600	240	180
		3	300	400	600	675	265	200
	15/32	2	320	425	640	730	285	215
		3	360	480	720	820	320	240
Sheathing single floor, and other grades covered in DOC PS1 and PS2	¾	2	240	320	480	545	215	160
		3	270	360	540	610	240	180
	7/16	2	255	340	505	575	230	170
		3	285	380	570	645	255	190
	15/32	2	290	385	575	655	255	190
		3	325	430	650	735	290	215
	19/32	2	320	421	640	730	285	215
		3	360	480	720	820	320	240

1. Minimum fastener penetration of 1¼" into the framing member is required.

2. For wind design, shear capacities may be increased 40% per section 2306.3.2 of the 2006 IBC, 2306.2.1 of the 2009 IBC, and 2306.2 of the 2012 IBC.

3. For shear loads of normal or permanent load duration as defined by the AF&PA NDS, the values in the table above must be multiplied by 0.63 or 0.56, respectively.

4. The minimum nominal width of framing members not located at boundaries or adjoining panel edges must be 2".

5. Framing at adjoining panel edges must be 3" nominal or wider, and screws must be staggered where both of the following conditions are met: (1) screws having penetration into framing of more than 1½" and (2) screws are spaced 3" o.c. or less.

6. Space screws maximum 12" o.c. along intermediate framing members (6" o.c. where supports are spaced 48" o.c.).

7. Framing at adjoining panel edges must be 3-inch nominal or wider, and screws must be staggered where screws are spaced 2" or 2½" on center.

8. See ICC-ES ESR-1472 for allowable shear loads for high load diaphragms.

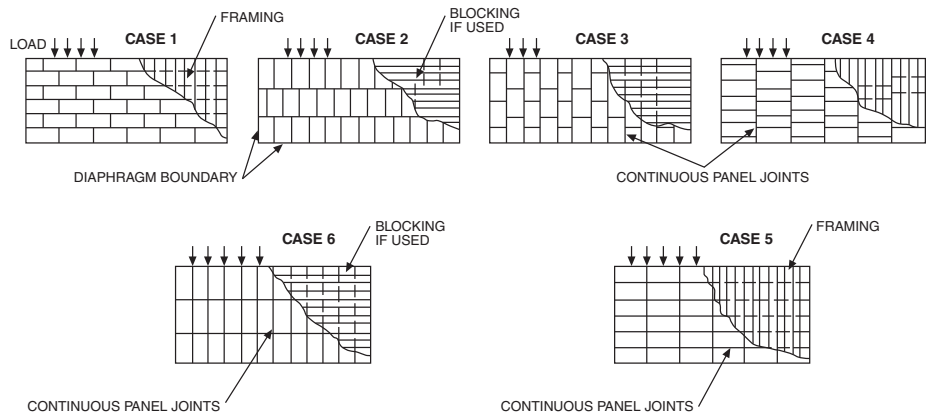

Technical Information

WSNTL – Allowable Withdrawal and Pull-Through Values for Wind or Seismic Loading¹⁻⁵

Model No.	Nominal Screw Length (in.)	Thread Length (in.)	Allowable Pull-Through ¹ (lbs.)				Reference Allowable Withdrawal Load Per Thread Penetration (lbs./in.)		
			Minimum Nominal Panel Thickness (in.)				Framing Member ³		
			OSB/Plywood Rated Sheathing, Exposure 1				2x SPF/HF	2x DFL	2x SP
			7/16	15/32	19/32	23/32			
WSNTL2LS	1.94	1.47	70	71	116	116	93	133	175
WSNTL212S	2.50	1.97							
WSNTL3S	3.00	2.17							

1. Use the lower of the pull-through or withdrawal values to determine axial design value.

2. Screws must be installed straight into the side grain of the wood main member with the screw axis at a 90° angle to the wood fibers.

3. The main framing member must be wood having a minimum specific gravity of 0.50 for DFL and SP main members, and 0.42 for SPF and HF main members. DFL is Douglas Fir-Larch. SP is Southern Pine. SPF is Spruce-Pine-Fir. HF is Hem-Fir.

4. Table based on testing conducted in accordance with AC233. Design values presented are based on average ultimate values and divided by 5.

5. Allowable loads are shown at the wood load duration factor of C_D = 1.0. Loads may be increased for load duration up to C_D = 1.6.

Load Tables, Technical Data and Installation Instructions

Strong-Drive® WSNTL SUBFLOOR Screw (cont.)

IBC Equivalent Prescriptive Fastening Schedule

IBC Table 2304.9.1 Connection	Fastening	Location
1" x 6" subfloor or less to each joist	2 screws	face
Wider than 1" x 6" subfloor to each joist	3 screws	face
1" diagonal brace to each stud and plate	2 screws	face
1" x 8" sheathing at each bearing	3 screws	face
Wider than 1" x 8" sheathing at each bearing	3 screws	face

IBC Equivalent Prescriptive Fastening Schedule for Diagonally Sheathed Lumber Diaphragms

Sheathing Nominal Dimension	Fastening to Intermediate and End-bearing Studs	Nailing at the Shear Panel Boundaries
	Number of Fasteners per Board	
1" x 6"	2	3
1" x 8"	3	4

IRC Equivalent Prescriptive Fastening Schedule¹⁻³

IRC Table R602.3(1) Building Elements	Fastening	Location
1" x 6" subfloor or less to each joist	2 screws	face
1" brace to each stud and plate	2 screws	face
1" x 6" sheathing to each bearing	2 screws	face
1" x 8" sheathing to each bearing	2 screws	face
Wider than 1" x 8" sheathing to each bearing	3 screws	face

Description of Building Materials	Description of Fastener ¹	Spacing of Fasteners	
		Edges (in.)	Intermediate Supports (in.)
Wood Structural Panels, Subfloor, Roof and Wall Sheathing to Framing²			
5/16" – 1/2"	1 screw (all lengths)	6	12
19/32" – 1"	1 screw (all lengths)	6	12
1 1/8"	1 screw (min. 2 1/2" length)	6	12
Wood Structural Panels, Combination Subfloor Underlayment to Framing³			
3/4" and less	1 screw (all lengths)	6	12
7/8" – 1"	1 screw (all lengths)	6	12
1 1/8"	1 screw (min. 2 1/2" length)	6	12

1. Screws shall be spaced not more than 6" on center at all supports where the spans are 48" or greater.
2. For regions having basic wind speed of 100 mph or less, screws for attaching panel roof sheathing to gable-end wall framing shall be spaced 6" on center. When wind speed is greater than 100 mph, screws for attaching panel roof sheathing to intermediate supports shall be spaced 6" on center for minimum 48" distance from ridges, eaves and gable-end walls; and 4" on center to gable-end wall framing.

3. Spacing of fasteners on floor sheathing panel edges applies to panel edges supported by framing members and required blocking and at all floor perimeters only. Spacing of fasteners on roof sheathing panel edges applies to panel edges supported by framing members and required blocking. Blocking of roof or floor sheathing panel edges perpendicular to framing members need no be provided except as required by other provisions of the code. Floor perimeter shall be supported by framing members or solid blocking.

Load Tables, Technical Data and Installation Instructions

Strong-Drive® WSNTL SUBFLOOR Screw (cont.)

Simpson Strong-Tie® Quik Drive WSNTL series #8 flathead, countersunk wood screws are a fast and reliable method for attaching 2-ply and 3-ply girder trusses.

WSNTL – Allowable Loads Comparison of Common Fasteners Used to Attach Truss Plies Together¹⁻⁶

Fastener	Length (in.)	Diameter (in.)	Shear (lbs.)			Withdrawal (lbs.)		
			DFL	SP	SPF	DFL	SP	SPF
WSNTL212S	2½	0.132	85	95	70	133	175	93
WSNTL3S	3	0.132	100	110	85	200	263	140
0.120" Collated Nail ⁵	3	0.120	81	89	69	44	56	28
0.131" Collated Nail ⁵	3	0.131	97	106	82	48	61	31

1. Table values are based on attachment of a 1½" side member to a 1½" main member of the same species and grade.
2. Table values are based on the 2012 National Design Specification (NDS), $C_D=1.0$. Values shall be multiplied by all applicable factors, such as duration of load, etc. except where noted.
3. Specific Gravities (G) assumed: DFL G = 0.50, SP G = 0.55, SPF G = 0.42.
4. The spacing of applied uniform loads to the multi-ply member shall not exceed 24 inches on center.
5. Assumes collated nail $F_y = 100$ ksi.
6. WSNTL212S and WSNTL3S withdrawal values based on testing per AC233.

Installation:

- Screw spacing shall be in accordance with the fastener schedule provided on the Truss Design Drawing or as otherwise approved by the Truss Designer. Screw spacing shall not exceed 12" on center and shall not be less than 3" on center.
- WSNTL series screws may be installed with the screw heads in either the loaded or unloaded ply. Do not overdrive screws.
- For 3-ply girder assemblies, the WSNTL screws may be installed from the same side as each ply is applied (no flipping of the truss is required) in accordance with BCSI (2006 edition). Girders that are fastened together at the jobsite must have the fastener heads visible for inspection.
- Stagger the screws in the 3rd ply a minimum of 1" from the screws installed into the first 2 plies.
- Individual screw locations may be adjusted up to ½ of the required screw spacing to avoid conflicts with other hardware or to avoid lumber defects. (3" minimum spacing still required.)
- Use minimum of 3" long fasteners to attach hangers to the girder truss.
- A 2500-rpm motor is recommended.

2-Ply Assembly

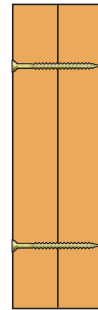

3-Ply Assemblies

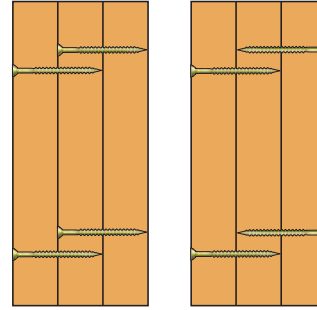

Truss Plant Installation

Jobsite Installation

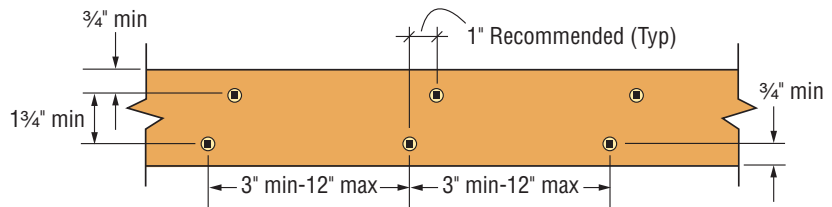

Typical Spacing for WSNTL Screw

Ply-To-Ply Connection Comparison for a 30 Ft Long 3-Ply Girder – Bottom Chord Loading

Sample bottom chord nailing requirement for 3-ply girder using .120x3" collated nails

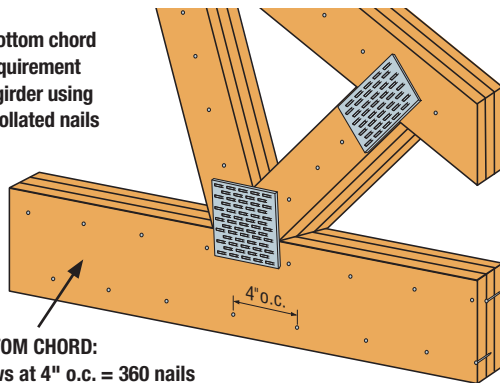

BOTTOM CHORD:
2 rows at 4" o.c. = 360 nails

Alternate fastening using WSNTL3S screw

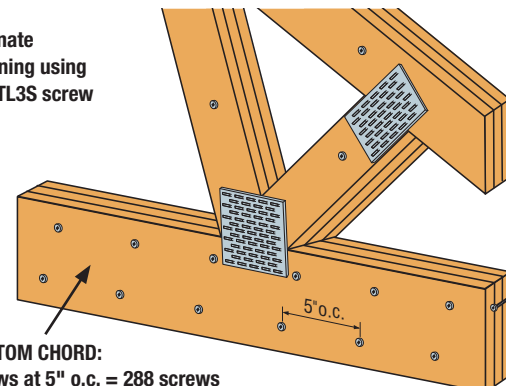

BOTTOM CHORD:
2 rows at 5" o.c. = 288 screws

Examples based on 3-ply girder spanning 30 ft., 2x6 Southern Pine bottom chords, 825 plf BC load and 1.15 load duration. Nail and screw spacing is repeated for each layer.

Load Tables, Technical Data and Installation Instructions

Strong-Drive® WSNTL SUBFLOOR Screw (cont.)

2"–3" WSNTL Fasteners Meet Code Requirements

As listed in ICC-ES ESR-1472, the WSNTL wood screws meet code requirements for the 2012, 2009, and 2006 International Building Code (IBC) and International Residential Code (IRC). Evaluation report recognized uses of the WSNTL wood screws include the following applications:

- Substitute for 8d and 10d nails in horizontal diaphragms per AWC SDPWS-2008 (IBC 2012) Tables 4.2A, 4.2B, and 4.2C; IBC 2009, Table 2306.3; 2006 IBC, Table 2306.3.2
- Code-prescribed wood connections per IBC Tables 2306.3.1 and 2304.9.1
- Single, diagonally-sheathed lumber diaphragms per AWC SDPWS Table 4.2C (2012 and 2009 IBC) and Table 2306.3.3 (2006 IBC)
- Prescriptive sheathing applications in IRC Table R602.3(1) and in structures regulated by the IRC where an engineered design is submitted in accordance with IRC R301.1.3

Guidelines for Fastening Diaphragms without Glue

The design of wood floor systems constructed with wood structural panel (WSP) sheathing fastened to framing considers the diaphragm performance of the system as presented in the codes (as affected by framing, sheathing thickness, sheathing layout and fastening) and may also consider the composite action of the sheathing with the framing system (composite action is the combined stiffness of the joist with the sheathing). The framing systems can be grouped into two classes: (1) sawn lumber and parallel-chord wood trusses, and (2) wood I-joists. WSNTL wood screws may be used as alternate fasteners to common nails in each floor class subject to certain constraints.

For Diaphragms with a Framing System that is Sawn Lumber or Parallel-Chord Wood Trusses

Simpson Strong-Tie WSNTL wood screws may be used as one-for-one substitutes for 10d common and smaller nails that are specified for horizontal diaphragm design in accordance with the 2012, 2009, and 2006 IBC and IRC.



The Original "No Glue" Solution for Subfloor



For Diaphragms with Wood I-Joist Framing Systems

I-joist manufacturers use the extra stiffness resulting from composite action when developing allowable floor joist span tables. Therefore, I-joist floor span tables generally assume glued-nailed construction.

1. For floor systems designed or intended to be glued-nailed:
 - The WSNTL wood screws may be substituted one-for-one for common nails, without glue, provided the maximum allowable I-joist span is reduced by 12" compared to the I-Joist manufacturer's glued-nailed spans. The screws shall have at least 1 1/4" penetration into the I-joist flange (or full penetration for flanges less than 1 1/4" thick).
 - Where glue is used with the screws, no reduction in span is required.
 - Check with the I-joist manufacturer for any additional diaphragm requirements.
2. For floor systems designed or intended to be nailed-only:
 - The WSNTL may be substituted one-for-one for common nails, with no reduction in span, provided at least 1 1/4" penetration into the I-joist flange is achieved (or full penetration for flanges less than 1 1/4" thick).
 - Check with the I-joist manufacturer for any additional diaphragm requirements.

Load Tables, Technical Data and Installation Instructions

Strong-Drive® XE EXTERIOR STRUCTURAL METAL Screw

Structural Metal Connectors

For More Product Information, see page 122

Single-Fastener Cold-Formed Steel Member Connection Load, Steel to Steel^{1, 2, 3}

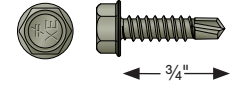

Model No.	Screw Size	Nominal Dia. (in.)	Washer Dia. (in.)	Load Description	Shear (lbs.)						Pull-Over (lbs.)						Pull-Out (lbs.)					
					Steel Thickness: mil (ga.)						Steel Thickness: mil (ga.)						Steel Thickness: mil (ga.)					
					27 (22)	33 (20)	43 (18)	54 (16)	68 (14)	97 (12)	27 (22)	33 (20)	43 (18)	54 (16)	68 (14)	97 (12)	27 (22)	33 (20)	43 (18)	54 (16)	68 (14)	97 (12)
XEQ34B1016	#10 x ¾"	0.19	0.4	Allowable Strength (ASD)	172	220	355	515	515	515	335	455	570	785	785	785	72	97	139	220	305	450
				Design Strength (LRFD)	274	355	570	775	775	775	530	725	915	1180	1180	1180	115	155	222	350	490	720
				Nominal Strength	421	545	875	1370	1420	1420	815	1110	1400	1985	2040	2040	178	237	340	535	750	1215

1. Screws and their connections have been tested per AISI Standard Test Method S904-08 and S905-08.

2. Loads are based on cold-formed steel members with a minimum yield strength, $F_y = 33$ ksi and tensile strength, $F_u = 45$ ksi for 43 mils (18 ga.) and thinner, and a minimum yield strength, $F_y = 50$ ksi and tensile strength, $F_u = 65$ ksi for 54 mils (16 ga.) and thicker.

3. Screws shall extend through the connection with a minimum of 3 exposed threads per AISI General Provisions Standard Section D1.3.

Screw Strength (lbs.)

Screw Size	Nominal Strength		Design Strength (LRFD) $\phi = 0.5$		Allowable Strength (ASD) $\Omega = 3.0$	
	P_{ss}	P_{ts}	ϕP_{ss}	ϕP_{ts}	P_{ss}/Ω	P_{ts}/Ω
#10 x ¾"	1545	2355	775	1180	515	785

Allowable Loads for Connectors in Trex Elevations

Model No.	Length (in.)	Fasteners	Allowable Loads (lbs.) ^{1, 2}	
			(F1)	
			43 mil (18 ga.)	68 mil (14 ga.)
L70Z	7	8 – #10	935	1265
LS70Z	6¾"	10 – #10	600	1070

1. Loads are for one part only.

2. Loads are for 8" headers/joists.

3. F1 load refers to the download or the uplift loads acting along the web of the joist/header.

Load Tables, Technical Data and Installation Instructions

Strong-Drive® PPSD SHEATHING-TO-CFS Screw

Common Application:

Wood structural panel/sheathing to cold-formed steel
(#8 – maximum thickness: 54 mils/16 ga.; #10 – maximum thickness: 97 mils/12 ga.)

Codes/Standards: ASTM C1513 compliant

For More Product Information, see pages 123, 196

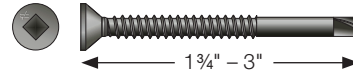

PPSD – Pull-Out Loads – Steel Connections

Model No.	Screw Size	Load Description	Pull-out Loads (lbs.)					
			Steel Thickness: mil (ga)					
			27 (22)	33 (20)	43 (18)	54 (16)	68 (14)	97 (12)
PPSD11516S0818 PPSDQ11516S0818	#8	ASD	63	87	119	183	—	—
		LRFD	100	139	190	295	—	—
		Nominal Strength	154	215	290	450	—	—
PPSD134S1016 PPSDQ134S1016	#10	ASD	80	128	194	315	425	480
		LRFD	128	205	310	500	680	765
		Nominal Strength	225	325	480	765	1045	1205
PPSD3S1016 PPSDQ3S1016	#10	ASD	80	128	194	315	425	480
		LRFD	128	205	310	500	680	765
		Nominal Strength	225	325	480	765	1045	1205

1. Screws and connections have been tested per AISI Standard Methods S904-08 and S905-08.

2. Values are based on cold-formed steel (CFS) members with a minimum yield strength, F_y of 33 ksi and minimum tensile strength, F_u of 45 ksi for 43 mil (18 ga) to 27 mil (22 ga), and a minimum yield strength, F_y of 50 ksi and minimum tensile strength, F_u of 65 ksi for 54 mils (16 ga) to 97 mils (12 ga).

3. For design purposes, steel sheet thicknesses are 0.0283" for 27 mil (22 ga), 0.0346" for 33 mil (20 ga), 0.0451" for 43 mil (18 ga), 0.0566" for 54 mil (16 ga), 0.0713" for 68 mil (14 ga) and 0.1017" for 97 mil (12 ga). The actual sheet thickness shall not be less than 95% of these design thickness as specified in AISI S100, Section A2.4.

4. A minimum of three exposed screw threads are required to achieve the loads in the Table.

PPSD – Pull-Through Loads – Rated Sheathing Panels

Model No.	Screw Size	Load Description	Reference Pull-Through Loads (lbs.)					
			Minimum Nominal Panel Thickness (in.)					
			Plywood			OSB		
			15/32	19/32	23/32	15/32	19/32	23/32
PPSD11516S0818 PPSDQ11516S0818	#8	ASD	83	84	116	49	109	117
		LRFD	179	181	250	106	235	255
		Nominal Strength	415	420	580	245	545	585
PPSD134S1016 PPSDQ134S1016	#10	ASD	75	85	118	52	111	114
		LRFD	162	184	255	112	240	245
		Nominal Strength	375	425	590	260	555	570
PPSD3S1016 PPSDQ3S1016	#10	ASD	75	85	118	52	111	114
		LRFD	162	184	255	112	240	245
		Nominal Strength	375	425	590	260	555	570

1. The tabulated values are based on testing per AC233.

2. ASD pull-through loads based on a factor of safety of 5 applied to the nominal strength value ($C_D = 1.0$, increases to $C_D = 1.6$ allowed where applicable).

3. LRFD load based on adjustment of ASD load per NDS 2012, Appendix N using $K_f = 3.32$, $\phi = 0.65$, and $\lambda = 1.0$.

Load Tables, Technical Data and Installation Instructions

Strong-Drive®

PHSD FRAMING-TO-CFS Screw

Common Applications:

- Cold-formed steel framing and sheet steel sheathing to cold-formed steel

Codes/Standards: ASTM C1513 compliant

For More Product Information, see page 195

PHSD Screw – Cold-Formed Steel Member Connection Loads, Steel to Steel

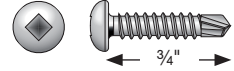

Model No.	Size	Nominal Dia. (in.)	Load Description	Shear (lbs.)			Pull-Over (lbs.)			Pull-Out (lbs.)		
				Steel Thickness: mil (ga) ⁶			Steel Thickness: mil (ga) ⁶			Steel Thickness: mil (ga) ⁶		
				27 (22)	33 (20)	43 (18)	27 (22)	33 (20)	43 (18)	27 (22)	33 (20)	43 (18)
PHSD34S0818	#8-18 x 3/4"	0.164	ASD Load	181	235	305	220	345	390	67	125	133
			LRFD Load	290	375	490	350	550	620	107	200	213
			Nominal Strength	410	590	765	540	845	955	164	310	325

1. Screws and screw connections have been tested per AISI Standard Test Method S904-08 and S905-08. This screw is not recommended for 16 gauge and thicker steel. Provide a 1/8" diameter predrilled hole in 16 gauge and thicker steel, if this screw should be used.
2. The tabulated ASD and LRFD allowable loads for cold-formed steel (CFS) members are based on the lower of the screw strength or the strength of the screw in the connected members per AISI S100-2007 Section E4.
3. The safety factor is based on AISI S100-07 Chapter F for tested connections.
4. The average ultimate/nominal values listed should not be used for design loads.
5. Values are based on CFS members with a minimum yield strength of $F_y = 33$ ksi and tensile strength of $F_u = 45$ ksi for 43 mil (18 ga) to 27 mil (22 ga), minimum yield strength of $F_y = 50$ ksi and $F_u = 65$ ksi for 54 mil (16 ga) to 97 mil (12 ga).
6. For design purposes, steel sheet thicknesses are 0.0283" for 27 mil, 0.0346" for 33 mil, 0.0451" for 43 mil, 0.0566" for 54 mil, 0.0713" for 68 mil, and 0.1017" for 97 mil. The actual sheet thickness shall not be less than 95% of these design thickness as specified in AISI S100-07 Section A2.4.
7. Screw diameters per AISI S200-07 General Provision Commentary Table D1.1.
8. Minimum required screw length is the lesser of 3/4" or the minimum length required for the screw to extend through the steel connection a minimum of 3 exposed threads per AISI S200-07 General Provisions Standard Section D1.3.
9. Screw head or washer diameter, d_w is 0.307".
10. The allowable load (ASD) values shown are not permitted to be increased for short-duration loads such as wind or earthquake loads.
11. The lower of the pull-over and pull-out allowable load should be used for tension design.
12. The tabulated shear values are based on the thinner steel member in connection. Steel thickness for both member must be in the range of 12-22 gauge.
13. See general load tables on page 271 for screw strength.

PHSD (#8) Screw – (Sheet Steel Sheathing to CFS) Nominal Shear Strength (R_n) for Wind (W) and Seismic (S) for Shear Walls¹ (lbs./ft.)

Assembly Description	Max. Aspect Ratio (h/w)	Fastener Spacing at Panel Edges ² (in.)				Designation Thickness ⁵ of Stud, Track and Blocking ⁷ (mils)
		6	4	3	2	
0.018" sheet steel, one side	2:1	485 (W) 390 (S)	—	—	—	33 (min.)
0.027" sheet steel, one side	4:1	—	1000	1085	1170	43 (min.)
	2:1 ³	647	710	778	845	33 (min.)
0.018" sheet steel, both sides	2:1	970 (W) 780 (S)	—	—	—	33 (min.)
0.027" sheet steel, both sides	4:1	—	2000	2170	2340	43 (min.)
	2:1 ³	1294	1420	1556	1690	33 (min.)

1. Nominal strength shall be multiplied by the resistance factor ($\phi = 0.6$, LRFD Seismic, $\phi = 0.65$, LRFD Wind) to determine design strength or divided by the safety factor ($\Omega = 2.5$, ASD Seismic, $\Omega = 2.0$, ASD Wind) to determine allowable strength.
2. Screws in the field of the panel shall be installed 12" (305 mm) on center (o.c.).
3. Shear wall height to width aspect ratio (h/w) greater than 2:1, but not exceeding 4:1, shall be permitted provided the nominal strength values are multiplied by 2w/h.
4. Wall studs and track shall be of ASTM A1003 Structural Grade 33 (Grade 230) Type H steel for members with a designation thickness of 33 and 43 mils.
5. In lieu of blocking, panel edges shall be permitted to be overlapped and attached to each other with screw spacing as required for panel edges. Where such a connection is used, tabulated design values shall be reduced 30%.
6. Maximum stud spacing 24" o.c.
7. Blocking, if applicable, shall be a minimum 33 mil 1 1/2" width.
8. Table based on Table C2.1-1 AISI Standard "North American Standard for Cold-Form Steel Framing-Lateral Design 2007 Edition with Supplement No. 1 and Commentary".

Load Tables, Technical Data and Installation Instructions

Strong-Drive® FPHSD FRAMING-TO-CFS Screw

Common Application:

Cold-formed steel framing and sheet steel sheathing to cold-formed steel

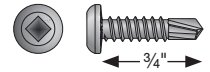
Codes/Standards: ASTM C1513 compliant**For More Product Information,** see pages 124, 195

FPHSD – Cold-Formed Steel Member Connection Loads, Steel to Steel

Model No.	Size	Nominal Dia. (in.)	Load Description	Shear (lbs.)						Pull-Over (lbs.)						Pull-Out (lbs.)					
				Steel Thickness: mil (ga)						Steel Thickness: mil (ga)						Steel Thickness: mil (ga)					
				27 (22)	33 (20)	43 (18)	54 (16)	68 (14)	97 (12)	27 (22)	33 (20)	43 (18)	54 (16)	68 (14)	97 (12)	27 (22)	33 (20)	43 (18)	54 (16)	68 (14)	97 (12)
FPHSD34S1016	#10-16 x 3/4"	0.190	ASD Load	175	235	380	570	570	280	365	485	695	740	740	78	105	156	240	340	505	
			LRFD Load	280	375	605	855	855	445	585	775	1110	1110	1110	126	168	250	380	545	805	
			Nominal Strength	395	535	860	1305	1305	685	895	1190	1705	2215	2215	205	260	385	585	840	1235	
FPHSD34S1214	#12-14 x 3/4"	0.216	ASD Load	205	260	410	610	610	240	330	430	630	840	1125	76	95	159	240	345	530	
			LRFD Load	330	420	650	975	975	390	530	685	1005	1340	1690	123	151	255	385	550	855	
			Nominal Strength	485	610	930	1385	1385	595	815	1050	1540	2060	2065	189	230	390	590	845	1295	

- Screws and connections have been tested per AISI Standard Method S904-08 and S905-08.
- The tabulated ASD and LRFD allowable loads for cold-formed steel (CFS) members are based on the lower of the screw strength or the strength of the screw in the connected members per AISI S100-07 Section E4.
- Values are based on CFS members with a minimum yield strength of $F_y = 33$ ksi and tensile strength of $F_u = 45$ ksi for 43 mil (18 ga) to 27 mil (22 ga), minimum yield strength of $F_y = 50$ ksi and $F_u = 65$ ksi for 54 mil (16 ga) to 97 mil (12 ga).
- For design purposes, steel sheet thicknesses are 0.0283" for 27 mil, 0.0346" for 33 mil, 0.0451" for 43 mil, 0.0566" for 54 mil, 0.0713" for 68 mil, and 0.1017" for 97 mil. The actual sheet thickness shall not be less than 95% of these design thickness as specified in AISI S100-07 Section A2.4.
- Screw diameters per AISI S200-07 General Provision Commentary Table D1.1.
- Minimum required screw length is the lesser of 3/4" or the minimum length required for the screw to extend through the steel connection a minimum of 3 exposed threads per AISI S200-07 General Provisions Standard Section D1.3.
- Screw head d_w for #10 and #12 screws is 0.357".
- The allowable load (ASD) values shown are not permitted to be increased for short-duration loads such as wind or earthquake loads.
- The lower of the pull-over and pull-out allowable load should be used for tension design.
- The tabulated shear values are based on the thinner steel member in connection. Steel thickness for both member must be in the range of 12-22 gauge.
- See the general load tables on page 271 for screw strength.

FPHSD (#10) Screw – (Sheet Steel Sheathing to CFS) Nominal Shear Strength (R_n) for Wind (W) and Seismic (S) for Shear Walls¹ (lbs./ft.)

Assembly Description	Max. Aspect Ratio (h/w)	Fastener Spacing at Panel Edges ² (in.)				Designation Thickness ⁵ of Stud, Track and Blocking ⁷ (mils)
		6	4	3	2	
0.018" sheet steel, one side	2:1	485 (W) 390 (S)	—	—	—	33 (min.)
0.027" sheet steel, one side	4:1	—	1000	1085	1170	43 (min.)
	2:1 ³	647	710	778	845	33 (min.)
0.018" sheet steel, both sides	2:1	970 (W) 780 (S)	—	—	—	33 (min.)
0.027" sheet steel, both sides	4:1	—	2000	2170	2340	43 (min.)
	2:1 ³	1294	1420	1556	1690	33 (min.)

- Nominal strength shall be multiplied by the resistance factor ($\phi = 0.6$, LRFD Seismic, $\phi = 0.65$, LRFD Wind) to determine design strength or divided by the safety factor ($\Omega = 2.5$, ASD Seismic, $\Omega = 2.0$, ASD Wind) to determine allowable strength.
- Screws in the field of the panel shall be installed 12" (305 mm) on center (o.c.).
- Shear wall height to width aspect ratio (h/w) greater than 2:1, but not exceeding 4:1, shall be permitted provided the nominal strength values are multiplied by 2w/h.
- Wall studs and track shall be of ASTM A1003 Structural Grade 33 (Grade 230) Type H steel for members with a designation thickness of 33 and 43 mils.
- In lieu of blocking, panel edges shall be permitted to be overlapped and attached to each other with screw spacing as required for panel edges. Where such a connection is used, tabulated design values shall be reduced 30%.
- Maximum stud spacing 24" o.c.
- Blocking, if applicable, shall be a minimum 33 mil 1 1/2" width.
- Table based on Table C2.1-1 AISI Standard "North American Standard for Cold-Form Steel Framing-Lateral Design 2007 Edition with Supplement No. 1 and Commentary".

Fastener Types

Fastener Types and Sizes Specified for Simpson Strong-Tie® Connectors

Many Simpson Strong-Tie connectors have been designed and tested for use with specific types and sizes of fasteners. The specified quantity, type and size of fastener must be installed in the correct holes on the connector to achieve published loads. Other factors such as fastener material and finish are also important. Incorrect fastener selection or installation can compromise connector performance and could lead to failure.

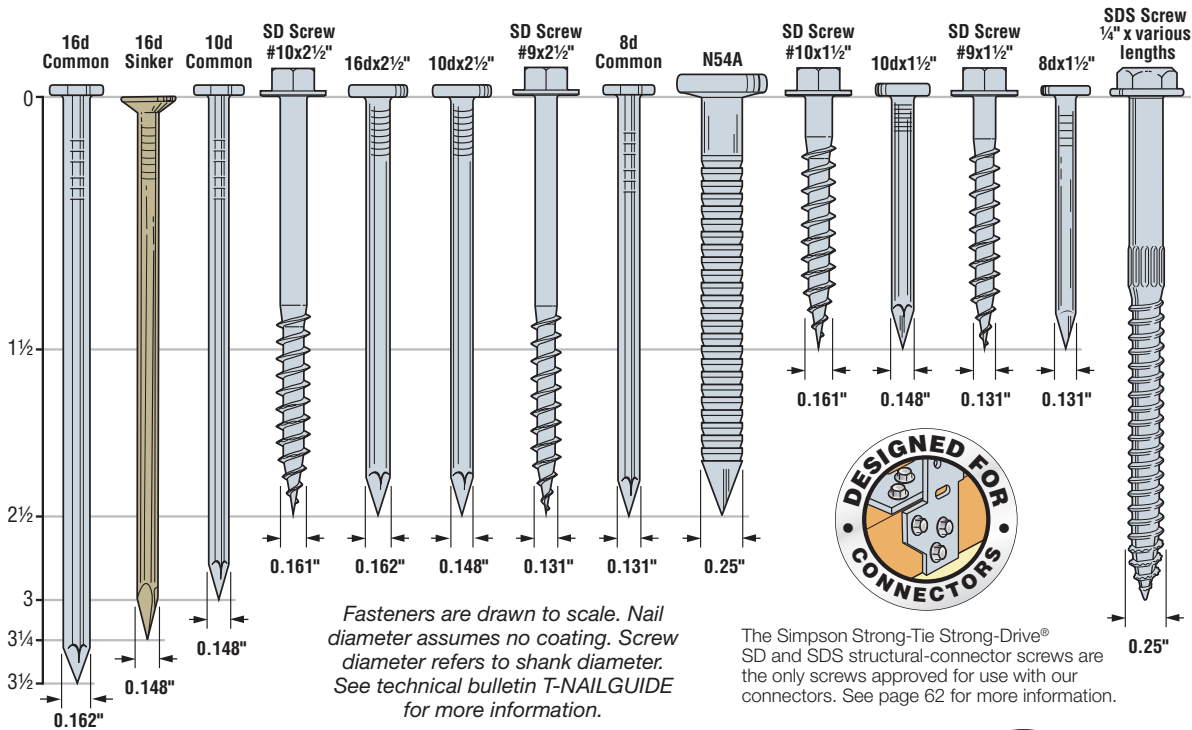

Fastener Design Information

In some cases it is desirable to install Simpson Strong-Tie face mount joist hangers and straight straps with nails that are a different type or size than what is called out in the load table. In these cases these reduction factors must be applied to the allowable loads listed for the connector.

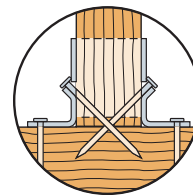

Double-shear nailing should use full length common nails

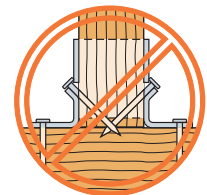

Shorter nails may not be used as double shear nails

Load Adjustment Factors for Optional Fasteners Used with Face Mount Hangers and Straight Straps¹⁻¹⁰

Catalog Nail	Replacement	Allowable Load Adjustment Factor	
		Face Mount Hangers	Straight Straps
16d common (0.162"x3 1/2")	10dx1 1/2 (0.148"x1 1/2")	0.64	0.84
16d common (0.162"x3 1/2")	10d common (0.148"x3") 12d common (0.148"x3 1/4") 16d sinker (0.148"x3 1/4")	0.84	0.84
16d common (0.162"x3 1/2")	16dx2 1/2 (N16) (0.162"x2 1/2")	1.00	1.00
10d common (0.148"x3")	10dx2 1/2 (0.148"x2 1/2")	0.85	1.00
10d common (0.148"x3")	10dx1 1/2 (0.148"x1 1/2")	0.77	1.00
16d sinker (0.148"x3 1/4")	10dx1 1/4 (0.148"x1 1/4")	0.64	1.00
10d common (0.148"x3")	16d sinker (0.148"x3 1/4")	1.00	1.00
8d common (0.131"x2 1/2")	8dx1 1/2 (0.131"x1 1/2")	0.85	1.00
10d common (0.148"x3")	8d common (0.131"x2 1/2")	0.83	0.83
16d common (0.162"x3 1/2")	SD#10x1 1/2 (0.161x1 1/2")	1.00	1.00
16dx2 1/2 (N16) (0.162x2 1/2")			
10d common (0.148"x3")			
16d sinker (0.148"x3 1/4")			
10d x1 1/2 (0.148"x1 1/2")	SD#9x1 1/2 (0.131x1 1/2")	1.00	1.00
8d common (0.131"x2 1/2")			
8dx1 1/2 (0.131"x1 1/2")			

1. Allowable load adjustment factors shown in the table are based on calculated reduction factors and are applicable for all face mount hangers and straight straps throughout this catalog, except as noted in the footnotes below.
2. Some products have been tested specifically with alternate fasteners and have allowable load adjustment factors or reduced capacities published on the specific product page which may differ from the values calculated using this table.
3. This table does not apply to hangers modified per the Hanger Options described on www.strongtie.com.
4. Unless noted otherwise, fasteners shorter than 3" in length may not be substituted for joist nails in double-shear hangers (i.e. LUS, MUS, HUS, HHUS, HGUS). For applications involving pneumatic nails, refer to technical bulletin T-PNEUMATIC.
5. Strong-Drive® SD screw substitutions in this table do not apply to sloped, skewed or double-shear hangers. For additional information and specific allowable loads, refer to www.strongtie.com/sd.
6. Nails and Strong-Drive SD screws may not be combined in a connection.
7. Do not substitute 10dx1 1/2" nails for face nails on slope and skew combinations or skewed only LSU and LSSU.
8. For straps installed over sheathing use a 2 1/2" long fastener minimum.
9. Where noted, use 0.80 for 10 ga, 11 ga, and 12 ga products when using SPF lumber.
10. Where noted, use 0.92 for 10 ga, 11 ga, and 12 ga products when using SPF lumber.

Load Tables, Technical Data and Installation Instructions

Strong-Drive® SDS HEAVY-DUTY CONNECTOR Screw

Heavy-Duty Simpson Strong-Tie® Connectors

The Simpson Strong-Tie® Strong-Drive® SDS screw is a ¼" diameter high-strength structural wood screw ideal for various connector installations as well as wood-to-wood applications.

Install Tips: A low-speed ½" drill with a ⅜" hex driver is the recommended tool for installation.

Codes/Standards: ICC-ES ESR-2236; City of L.A. RR25711
U.S. Patents 6,109,850; 5,897,280; 7,101,133

For More Product Information, see page 61

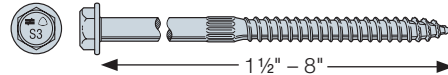

SDS – Allowable Shear Loads-Steel Side-Plate Applications¹⁻⁵

Size (in.)	Coating/Material	Model No.	DF/SP Allowable Shear Loads (lbs)			SPF/HF Allowable Loads (lbs)		
			Steel Side Plate Thickness, mil (ga)			Steel Side Plate Shear, mil (ga)		
			54 (16)	68 and 97 (14 and 12)	123 (10) or greater	54 (16)	68 and 97 (14 and 12)	123 (10) or greater
¼ x 1½	Double-Barrier Coating	SDS25112	250	250	250	180	180	180
¼ x 2		SDS25200	250	290	290	180	210	210
¼ x 2½		SDS25212	250	390	420	180	280	300
¼ x 3		SDS25300	250	420	420	180	300	300
¼ x 3½		SDS25312	250	420	420	180	300	300
¼ x 4½		SDS25412	250	420	420	180	300	300
¼ x 5		SDS25500	250	420	420	180	300	300
¼ x 6		SDS25600	250	420	420	180	300	300
¼ x 8		SDS25800	250	420	420	180	300	300
¼ x 1½	Type-316 Stainless Steel	SDS25112SS	250	250	250	180	180	180
¼ x 2		SDS25200SS	250	290	290	180	210	210
¼ x 2½		SDS25212SS	250	390	420	180	280	300
¼ x 3		SDS25300SS	250	420	420	180	300	300
¼ x 3½		SDS25312SS	250	420	420	180	300	300

1. Allowable loads for SDS screws are based on ICC-ES Code Report ESR-2236. Screws may be provided with the 4CUT™ or Type-17 point.
2. Allowable loads are shown at the wood load duration factor of $C_D = 1.00$. Loads may be increased for load duration up to a $C_D = 1.60$.

3. Allowable withdrawal load for DF/SP/SCL is 172 lbs./in. and for SPF/HF withdrawal is 121 lbs./in.. Total withdrawal load is based on actual thread penetration into the main member.
4. LSL wood-to-wood applications that require 4½", 5", 6" and 8" SDS screws are limited to interior-dry use only.
5. Minimum spacing requirements are listed in ICC-ES ESR-2236.

Load Tables, Technical Data and Installation Instructions

Strong-Drive® SDS HEAVY-DUTY CONNECTOR Screw (cont.)

SDS – Allowable Shear Loads – Douglas Fir-Larch and Southern Pine Lumber^{5,6,7}

Size (in.)	Model No.	DF/SP Allowable Shear Loads ²													
		Wood Side Plate Thickness (in.)													
		½	⅝	¾	1	1⅛	1¼	1½	1¾	2½	3	3½	4	4½	
¼ x 2	SDS25200	145	—	—	—	—	—	—	—	—	—	—	—	—	
¼ x 2½	SDS25212	165	165	170	165	—	—	190 ¹	—	—	—	—	—	—	
¼ x 3	SDS25300	165	165	170	185	195	205	280 ¹	—	—	—	—	—	—	
¼ x 3½	SDS25312	165	165	170	185	195	205	340 ¹	340 ¹	—	—	—	—	—	
¼ x 4½	SDS25412	165	165	170	185	195	205	350 ¹	340 ¹	230	200	—	—	—	
¼ x 5	SDS25500	165	165	170	185	195	205	350 ¹	340 ¹	230	230	200	—	—	
¼ x 6	SDS25600	165	165	170	185	195	205	350 ¹	340 ¹	340 ¹	340 ¹	340 ¹	230	200	
¼ x 8	SDS25800	165	165	170	185	195	205	350 ¹	340 ¹	340 ¹	340 ¹	340 ¹	230	230	

SDS – Allowable Shear Loads - Spruce-Pine-Fir and Hem-Fir^{5,6,7}

Size (in.)	Model No.	SPF/HF Allowable Shear Loads ²													
		Wood Side Plate Thickness (in.)													
		½	⅝	¾	1	1⅛	1¼	1½	1¾	2½	3	3½	4	4½	
¼ x 2	SDS25200	105	—	—	—	—	—	—	—	—	—	—	—	—	
¼ x 2½	SDS25212	130	135	130	120	—	—	135 ¹	—	—	—	—	—	—	
¼ x 3	SDS25300	130	140	140	150	150	145	200 ¹	—	—	—	—	—	—	
¼ x 3½	SDS25312	130	140	140	150	155	165	245 ¹	245 ¹	—	—	—	—	—	
¼ x 4½	SDS25412	130	140	140	150	155	165	250 ¹	245 ¹	190	160	—	—	—	
¼ x 5	SDS25500	130	140	140	150	155	165	250 ¹	245 ¹	190	190	160	—	—	
¼ x 6	SDS25600	130	140	140	150	155	165	250 ¹	245 ¹	245 ¹	245 ¹	245 ¹	190	160	
¼ x 8	SDS25800	130	140	140	150	155	165	250 ¹	245 ¹	245 ¹	245 ¹	245 ¹	195	195	

1. Noted loads are based on ICC-ES Code Report ESR-2236 and/or testing per ICC AC233 and assume a minimum main member thickness of the screw length minus the side member thickness. All other allowable loads are based on the 2005 and 2012 National Design Specification (NDS) and a minimum penetration of $6D = 1.45"$ into the main member.
2. Values are valid for a connection involving only two members. Where the side and main members have different specific gravities, the lower values shall be used.
3. Allowable loads are also applicable to structural composite lumber (e.g., LVL, PSL, and LSL) having an equivalent specific gravity of 0.50 or greater.

4. Allowable loads are shown at the wood load duration factor of $C_D = 1.00$. Loads may be increased for load duration by the building code up to a $C_D = 1.60$. The Designer shall apply all adjustment factors required per NDS.
5. Loads are based on installation into the side grain of the wood members with the screw axis perpendicular to the wood fibers.
6. Loads apply to corresponding stainless-steel models.
7. For in service moisture greater than 19% use $C_M = 0.7$.

Load Tables, Technical Data and Installation Instructions

Strong-Drive® SDS HEAVY-DUTY CONNECTOR Screw (cont.)

SDS – Allowable Double-Shear Loads – Douglas Fir-Larch, Southern Pine, Spruce-Pine-Fir¹⁻⁵

Size (in.)	Model No.	Side Members	Allowable Shear Loads (lbs.)		
			DF	SP	SPF
¼ x 3½	SDS25300	2 ³ / ₃₂ " Wood Structural Panel Rated Sheathing	355	325	305
¼ x 4½	SDS25412	2x Solid Sawn	395	475	335

1. Allowable loads are based on Simpson Strong-Tie® laboratory testing with a safety factor of 5 applied to the average ultimate test load.
2. Allowable loads are based on 1½" thick main members and assume no gap between side and main members.
3. Allowable loads are shown at the wood load duration factor of C_D = 1.00. Loads may be increased for load duration by the building code up to a C_D = 1.60. The designer shall apply all adjustment factors required per NDS.
4. For applications with 2x side members, use allowable loads based on the lower of side member or main member species.
5. The Designer is responsible for the design of wood members.

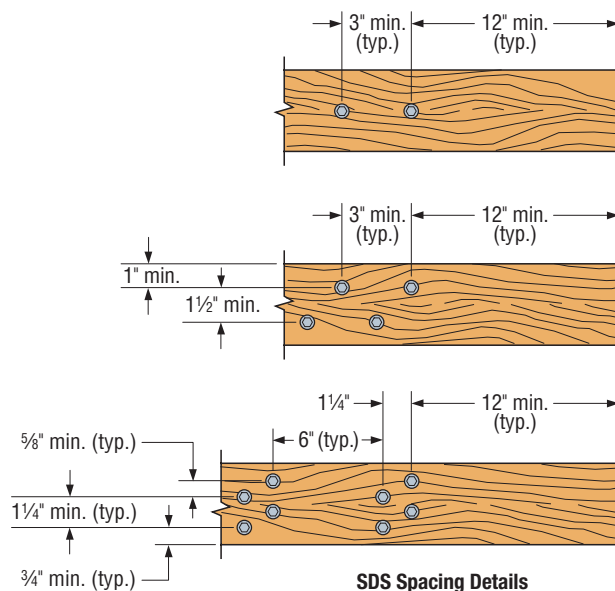

SDS Spacing Details

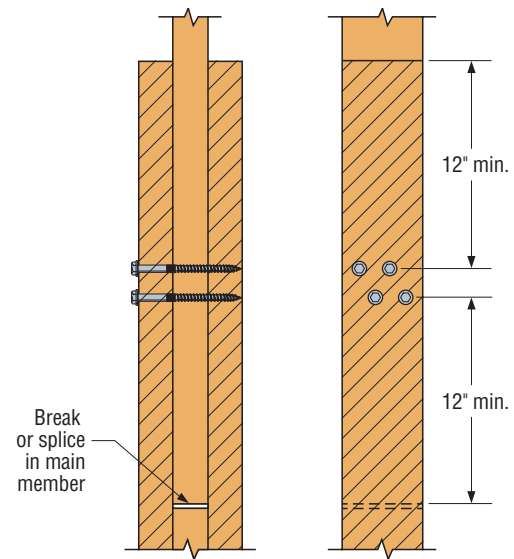

Typical SDS Double Shear Installation

SDS – Allowable Shear Loads – Installations into the Narrow Face of 2X SPF, HF, DFL, SP Lumber¹⁻⁶

Size (in.)	Model No.	Wood Side Member Actual Thickness (in.)	Minimum Main Member Penetration ⁵ (in.)	DF/SP Allowable Shear Loads (lbs.)	SPF/HF Allowable Shear Loads (lbs.)
¼ x 3½	SDS25312	1½	2	250	190
¼ x 4½	SDS25412			250	190

1. Allowable loads are based on testing per ICC AC233 and are limited to parallel-to-grain loaded solid sawn main members (2" nominal). Wood side members may be loaded parallel or perpendicular to grain (see footnote 4).
2. DF/SP allowable loads are based on wood members having a minimum specific gravity of 0.50, and SPF/HF allowable loads are based on wood members having a minimum specific gravity of 0.42. Where the side and main members have different specific gravities, the lower values shall be used.
3. Allowable loads are shown at the wood load duration factor of C_D = 1.00. Loads may be increased for load duration by the building code up to a C_D = 1.60.
4. Minimum spacing of fasteners is 3" o.c., minimum end distance is 3" for all parallel-to-grain loaded members, or 4" for all perpendicular-to-grain loaded members, and minimum edge distance is ¾" for all parallel-to-grain loaded members, or 1½" for perpendicular-to-grain loaded side members.
5. Screws may be installed with an intermediate layer of wood structural panel between the side and main member provided the wood structural panel is fastened to the main member per code and the minimum penetration of the screw into the main member (excluding the wood structural panel) is met.

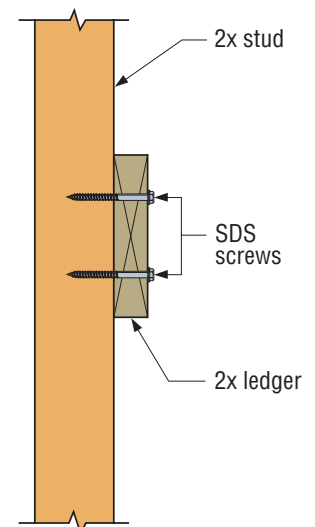

Ledger-to-Stud Assembly

Load Tables, Technical Data and Installation Instructions

Strong-Drive® SDS HEAVY-DUTY CONNECTOR Screw (cont.)

Code-Compliant Spacing for a Sawn Lumber Deck Ledger to Band Joist¹⁻⁵

Loading Condition	Ledger Nominal Size (in.)	SDS Screw Length (in.)	Band Joist Material and Size	Maximum Deck Joist Span						
				Up to 6 ft.	Up to 8 ft.	Up to 10 ft.	Up to 12 ft.	Up to 14 ft.	Up to 16 ft.	Up to 18 ft.
				Maximum On-Center Spacing of Fasteners (in.)						
40 psf Live 10 psf Dead	2x	3½	2" Nominal Sawn Lumber	13	10	8	6	5	5	4
	2-2x³	5								
	2x	3½	1" Min. Oriented Strand Board (OSB) Rim Board	12	9	7	6	5	4	4
	2x	3½	1½" Min. Oriented Strand Board (OSB) Rim Board or 1¼" Min. Structural Composite Lumber	15	11	9	7	6	5	5
60 psf Live 10 psf Dead	2x	3½	2" Nominal Sawn Lumber	9	7	5	4	4	3	3
	2-2x³	5								
	2x	3½	1" Min. Oriented Strand Board (OSB) Rim Board	8	6	5	4	3	3	2
	2x	3½	1½" Min. Oriented Strand Board (OSB) Rim Board or 1¼" Min. Structural Composite Lumber	10	8	6	5	4	4	3

1. Solid-sawn band joists shall be Spruce-Pine-Fir, Hem-Fir, Douglas Fir-Larch, or Southern Pine species. Ledger shall be Hem-Fir, Douglas Fir-Larch, or Southern Pine species.
2. Fastener spacings are based on single fastener testing of the Strong-Drive® SDS screw with a safety factor of 5.0 and include NDS wet service adjustment factor.
3. Multiple ledger plies shall be fastened together per code independent of the SDS screws.
4. SDS screw spacing values (above) are equivalent to 2009 IRC Table R502.2.2.1 and 2012 IRC Table R507.2, based on testing of the Strong-Drive® SDS screw with a factor of safety of 5.0. The table above also provides SDS screw spacing for a wider range of materials commonly used for band joists, and an alternate loading condition as required by some jurisdictions.
5. Screw models SDS25312, SDS25312SS and SDS25500.

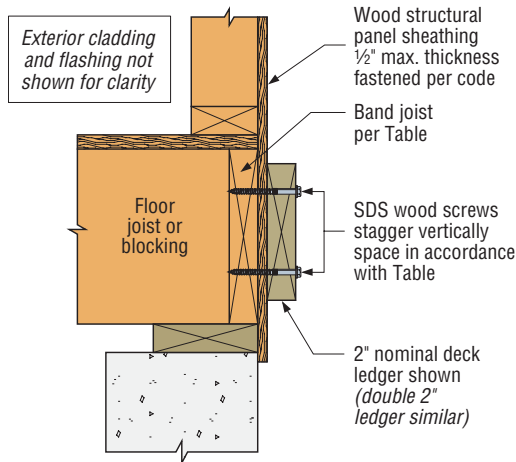

Ledger-to-Band Joist Assembly
(Wood-framed lower floor acceptable, concrete wall shown for illustration purposes)

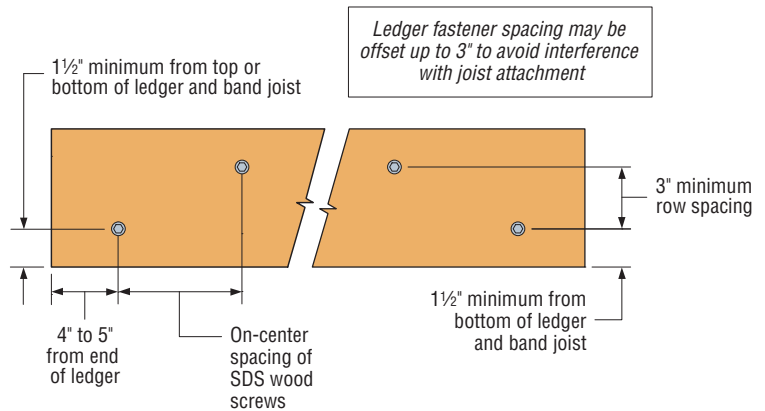

SDS Screw Spacing Detail

Load Tables, Technical Data and Installation Instructions

Strong-Drive® **SDS HEAVY-DUTY CONNECTOR Screw (cont.)**

SDS – Allowable Shear Values for Sole-to-Rim Connections¹⁻⁶

Size (in.)	Model No.	Sole Plate Nominal Size	Minimum Penetration into Rim Board (in.)	Allowable Loads (lbs)							
				2x DF/SP Rim Board		2x SPF/HF Rim Board		1 1/4" Min. LVL Rim Board		1 1/4" Min. LSL Rim Board	
				DF/SP Sole Plate	SPF/HF Sole Plate	DF/SP Sole Plate	SPF/HF Sole Plate	DF/SP Sole Plate	SPF/HF Sole Plate	DF/SP Sole Plate	SPF/HF Sole Plate
1/4 x 4.5	SDS25412	2x	2	250	190	190	190	190	190	220	190
1/4 x 5	SDS25500	2x	2	250	190	190	190	190	190	220	190
1/4 x 6	SDS25600	2x or 3x	2	250	190	190	190	190	190	220	190

1. Allowable loads are based on testing per ICC-ES AC233 and are limited to parallel-to-grain loading.
2. Allowable loads are shown at the wood load duration factor of $C_D = 1.00$. Loads may be increased for load duration by the building code up to a $C_D = 1.60$.
3. Minimum spacing of the SDS for solid sawn applications is 3" o.c., minimum end distance is 3", and minimum edge distance is 5/8".
4. Minimum spacing of the SDS for LVL and LSL applications is 6" o.c., minimum end distance is 6", and minimum edge distance is 5/8".
5. Wood structural panel up to 1 1/8" thick is permitted between the sole plate and rim board provided it is fastened to the rim board per code and the minimum penetration of the screw into the rim board is met.
6. A double 2x sole plate is permitted provided it is independently fastened per the code and the minimum screw penetration per the table is met.

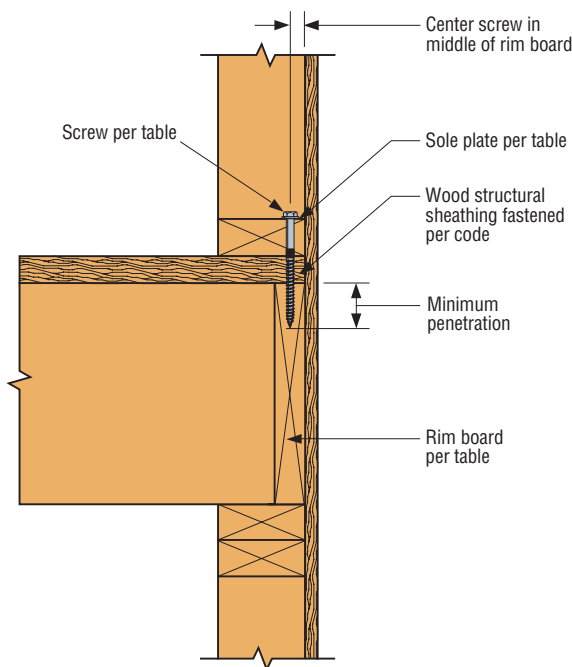

Load Tables, Technical Data and Installation Instructions

Strong-Drive® SD CONNECTOR Screw

Simpson Strong-Tie® Connectors

Mechanically-galvanized coating meets ASTM B695 Class 55 is recommended for use with certain preservative-treated woods and recognized as an alternate to hot-dip galvanized in ESR-3046; it is compliant with the 2006, 2009, and 2012 International Residential Code® (2006 Section R319.3, 2009 and 2012 Section R317.3.1).

Codes/Standards: ICC-ES ESR-3046;
U.S. Patent 7,101,133

For More Product Information, see page 62

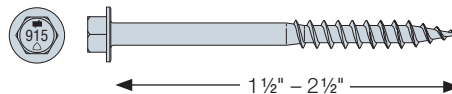

SD – Allowable Shear Loads – Steel Side Plate

Size (in.)	Model No.	Thread Length (in.)	Allowable Shear Loads with Steel Side Plates (lbs.)	
			DF/SP	SPF/HF
#9x1 1/2	SD9112	1	171	112
#9x2 1/2	SD91212	1	200	112
#10x1 1/2	SD10112	1	173	138
#10x2 1/2	SD10212	1	215	165

1. Loads are given for C_D=1.0 and may be increased for load duration per the building code to C_D=1.60
2. Steel side plate thickness is 33 to 100 mils (20 – 12 ga).

SD – Allowable Shear Loads – DFL, SP, SPF, HF Side Plate

Size (in.)	Model No.	Thread Length (in.)	DF/SP Allowable Shear Loads (lbs.)			SPF/HF Allowable Shear Loads (lbs.)		
			Wood Side Plate Thickness (in.)			Wood Side Plate Thickness (in.)		
			1 5/32 - 1/2	2 3/32 - 3/4	1 1/2	1 5/32 - 1/2	2 3/32 - 3/4	1 1/2
#9x1 1/2	SD9112	1	105	—	—	93	—	—
#9x2 1/2	SD9212	1	118	133	130	99	94	109
#10x1 1/2	SD10112	1	127	—	—	102	—	—
#10x2 1/2	SD10212	1	147	168	152	106	126	123

1. Allowable loads are shown at the wood load duration factor of C_D = 1.00. Loads may be increased for load duration per the building code up to a C_D = 1.60.
2. The 1 5/32" and 2 3/32" side members must be plywood or OSB with minimum equivalent specific gravities of 0.50 for DF and SP design values, and 0.42 for SPF and HF design values.
3. Loads are based on installation into the side grain of the wood members with the screw axis perpendicular to the wood fibers.

SD – Allowable Withdrawal Loads – DFL, SP, SPF, HF Lumber

Size	Model No.	Fastener Length (in.)	Thread Length (in.)	Reference Withdrawal Design Value, W (lbs./in.)	
				DFL and SP Main Member	SPF and HF Main Member
#9 x 1 1/2	SD9112	1.5	1.0	173	122
#9 x 2 1/2	SD9212	2.5			
#10 x 1 1/2	SD10112	1.5		173	122
#10 x 2 1/2	SD10212	2.5			

1. The tabulated reference withdrawal design value, W, is in pounds per inch of the thread penetration into the side grain of the main member.
2. Tabulated reference withdrawal design value, W, must be multiplied by all applicable adjustment factors from the NDS as referenced in the IBC or IRC.
3. Embedded thread length is that portion held in the main member including the screw tip.
4. For connections with 1 5/32 inch thick plywood or OSB side members, reference withdrawal design values, W, must be limited by the head pull-through design value of 130 lbs.

Load Tables, Technical Data and Installation Instructions

Strong-Drive®

SD CONNECTOR Screw (cont.)

Connectors approved for use with the Strong-Drive® SD structural-connector screw

Model No.	SD9		SD10		Model No.	SD9		SD10		Model No.	SD9		SD10	
	#9x1 1/2"	#9x2 1/2"	#10x1 1/2"	#10x2 1/2"		#9x1 1/2"	#9x2 1/2"	#10x1 1/2"	#10x2 1/2"		#9x1 1/2"	#9x2 1/2"	#10x1 1/2"	#10x2 1/2"
A21 ¹	•				L70 ¹	•				MSTI36 ¹	•			
A23 ¹	•				L90 ¹	•				MSTI48 ¹	•			
A33 ¹	•				LCE4 ¹			•		MSTI60 ¹	•			
A34 ¹	•				LPC4Z ¹	•				MSTI72 ¹	•			
A35 ¹	•				LSCZ	•				MTS12 ¹	•			
A44 ¹	•				LSTA9 ¹	•				MTS16 ¹	•			
ABA44 ¹	•				LSTA12 ¹	•				MTS20 ¹	•			
ABA44R ¹	•				LSTA15 ¹	•				NS1 ²	•			
ABA46 ¹			•		LSTA18 ¹	•				NS2 ²	•			
ABA46R ¹			•		LSTA21 ¹	•				PBS44A			•	
ABA66 ¹			•		LSTA24 ¹	•				PC44 ¹			•	
ABA66R ¹			•		LSTA30 ¹	•				PC44-16 ¹			•	
ABU44 ¹			•		LSTA36 ¹	•				PF24		•		
AC4 (Max) ¹			•		LSTI49 ¹	•				PF24A		•		
AC4R (Max) ¹			•		LSTI73 ¹	•				PF26		•		
AC6 (Max) ¹			•		LTP4 ¹	•				PF26A		•		
AC6R (Max) ¹			•		LU24 (10d) ¹	•				PF26A		•		
BC4 ¹			•		LU26 (10d) ¹	•				PFD24		•		
BC40 ¹			•		LU28 (10d) ¹	•				PFDS24		•		
BC60 ¹			•		LU210 (10d) ¹	•				PFD26		•		
BCS2-2/4 ¹		•			LUC26Z (10d) ¹	•				PFD26L		•		
CTS218	•				LUC26Z (16d) ¹			•		PFDS26		•		
DJT14Z ¹				•	LUC210Z (10d) ¹	•				PSPN58Z ²			•	
DPT5Z ²	•				LUC210Z (16d) ¹			•		RR ¹	•			
DPT7Z ²	•				LUS24 ¹		•			RSP4 ¹	•			
EPB44			•		LUS24-2 ¹				•	ST9 ¹			•	
EPB44PHDG			•		LUS26 ¹		•			ST12 ¹			•	
EPC44 ¹			•		LUS26-2 ¹				•	ST18 ¹			•	
EPC44-16 ¹			•		LUS28 ¹		•			ST215 ¹			•	
FB24 ²	•				LUS28-2 ¹				•	ST2122 ¹			•	
FB24R ²	•				LUS28-2 ¹				•	ST22 ¹			•	
FB26 ²	•				LUS210 ¹		•			ST292 ¹			•	
FBR24Z ²	•				LUS210-2 ¹				•	ST2215 ¹			•	
FPBM44 ²	•				MST27 ¹				•	ST6215 ¹			•	
FWH2 ²	•				MST37 ¹				•	ST6224 ¹			•	
GA1 ¹	•				MST48				•	ST6236 ¹			•	
GA2 ¹	•				MST60				•	THASR/L29	•	•		
H1 ¹	•				MST72				•	THASR/L29-2	•	•		
H2.5 ¹	•				MSTA9 ¹	•				THASR/L422		•		
H2.5A ¹	•				MSTA12 ¹	•				TP15 ²	•			
H4 ¹	•				MSTA15 ¹	•				TP311 ²	•			
H5 ¹	•				MSTA18 ¹	•				TP35 ²	•			
H8 ¹	•				MSTA21 ¹	•				TP37 ²	•			
H10 ¹	•				MSTA24 ¹	•				TP39 ²	•			
HPTZ			•		MSTA30 ¹	•				TP411 ²	•			
HRS12 ¹	•				MSTA36 ¹	•				TP45 ²	•			
HRS6 ¹	•				MSTA49 ¹	•				TP47 ²	•			
HRS8 ¹	•				MSTC28 ¹	•				TP49 ²	•			
HTP37Z ¹	•				MSTC40 ¹	•				TP57 ²	•			
HUS26 ¹				•	MSTC52 ¹	•				TPA37 ²	•			
HUS28 ¹				•	MSTC66 ¹	•				TPA39 ²	•			
L30 ¹	•				MSTC78 ¹	•				TPA57 ²	•			
L50 ¹	•				MSTI26 ¹	•				VTCR	•	•		

1. These connectors are code listed under ICC-ES ESR-3096 when installed with the SD screw. Check with your local building department to determine whether the correct size of SD structural-connector screw may be used as a suitable substitute for nails.
2. These connectors are not load rated.

Since testing of the SD structural-connector screw is ongoing, Simpson Strong-Tie will continue to add newly-approved connectors to this list. For the most current list of approved connectors, load values and applications visit www.strongtie.com/sd.

Load Tables, Technical Data and Installation Instructions

Strong-Drive® SCNR RING-SHANK CONNECTOR Nail

Simpson Strong-Tie® Connectors

SCNR Ring-Shank Connector nails are the best choice for achieving maximum load values in stainless-steel connectors.

For More Product Information, see pages 102, 152

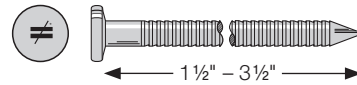

When installing galvanized connectors and straps, use an SCN that is zinc galvanized. If the connectors and straps are stainless steel, then stainless steel SCNs shall be used. Recent testing by the USDA Forest Service, Forest Products Laboratory and Simpson Strong-Tie has shown that stainless steel nails with smooth shanks do not have the same withdrawal resistance as smooth-shank carbon steel and smooth-shank galvanized nails. However, ring-shank stainless steel nails do not underperform the carbon steel nails. For further information see Forest Products Laboratory Techline article “Withdrawal Strength of Stainless Steel Nails (August 2012)” and the Simpson Strong-Tie Structural Engineering Blog, <http://seblog.strongtie.com/2013/10/why-your-nds-nail-calcs-could-be-wrong-and-what-you-can-do-about-it/>.

In addition, recent load testing at Simpson Strong-Tie indicates that allowable load values for some Simpson Strong-Tie stainless-steel connectors have changed. Refer to www.strongtie.com/products/categories/zmax.html for a list of connectors available in stainless steel that includes links to load tables for carbon steel and stainless steel smooth-shank nail installations. If a reduced value is shown for a stainless steel connector used with smooth-shank stainless steel nails, full allowable carbon steel connector loads may be achieved if the stainless steel connector is installed with Simpson Strong-Tie **SCNR ring-shank** stainless steel nails. See the *Stainless Steel Connector Nail Substitution Chart* for the required replacement stainless steel ring-shank nail.

Stainless-Steel Connector Nail Substitution Chart¹

Catalog Specified Smooth-Shank Carbon Steel Nail		Replacement Ring-Shank Stainless Steel Nail, Type 316 Steel	
Type	Size (inches)		Model
N8	0.131 x 1.5		SSNA8
8d Common	0.131 x 2.5		SSA8D
N10	0.148 x 1.5		SSNA10
10d Common	0.148 x 3.0		SSA10D
16d Common	0.162 x 3.5		SSA16D

1. Tabulated nails are hand-drive nails; collated nails are available for some sizes. Contact Simpson Strong-Tie for collated model numbers.

Over-driven Nails in Connectors and Straps

A nail that is installed such that the head deforms the steel of the connector or strap is considered over-driven. Extra care to prevent over-driven nails should be taken when installing power-driven nails. Simpson Strong-Tie has evaluated the effect of over-driven nails in connectors and straps. No load reductions for connectors or straps apply as a result of over-driven nails if all of the following conditions are met:

- Connectors and straps are 14-, 16-, or 18-gauge steel.
- The top of the nail head is not driven past flush with the face of the metal hardware.
- The nail goes through an existing fastener hole without enlarging it.
- The steel around the hole is not torn or damaged other than denting caused by the nail head.

Load Tables, Technical Data and Installation Instructions

Strong-Drive® SCN SMOOTH-SHANK CONNECTOR Nail

Simpson Strong-Tie® Connectors

For More Product Information, see pages 103, 152

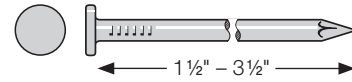

Simpson Strong-Tie connectors have been designed and tested with specific types of nails, which are generally referred to as Structural Connector Nails (SCN). The specified nail size, type and quantity must be installed in the correct holes of the connector or strap to achieve the published loads for the hardware. The dimensions and bending yield strength characteristics needed for nails used in Simpson Strong-Tie connectors and hardware are given in the table SCN smooth-shank connector nails and common nails approved for use with Simpson Strong-Tie connectors. The designer and installer must be sure that the correct Simpson Strong-Tie fastener is specified and installed. In cases where the installed nail matches the criteria of the nail specified for the hardware, full hardware design values result.

SCN Smooth-Shank Connector nails and common nails approved for use with Simpson Strong-Tie connectors^{1,2,3}

Fastener	Diameter (in.)	Length (in.)	Head Style	Head Diameter (in.)	Minimum Bending Yield Strength (psi) ⁴
N8	0.131	1.5	round	0.281	100,000
8d common	0.131	2.5	round	0.281	100,000
N10	0.148	1.5	round	0.281	90,000
N10D	0.148	2.5	round	0.281	90,000
10d common	0.148	3	round	0.281 ⁵	90,000
N16	0.162	2.5	round	0.281	90,000
16d common	0.162	3.5	round	0.281 ⁵	90,000

1. Tolerance on diameter and length per ASTM F1667.
2. Tolerance on head diameter (± 0.0015 in.)
3. All dimensions are prior to coating.
4. Tested in accordance with ASTM F1575.
5. Minimum head diameter shown; actual head diameters on 10d and 16d common nails are larger.

Power-driven SCNs are often used to install Simpson Strong-Tie connectors and straps. Power-driven nails must have the same dimensions and bending yield strength as hand-driven nails. Dedicated power nailers are designed to drive nails of specific lengths that may be less than the length required to achieve full design values for the connector or strap hardware. When connectors and straps are installed with power-driven nails or hand-driven nails that are a different type or size than those called out in the connector and strap specifications, adjustment factors as given on www.strongtie.com must be applied to the allowable loads for the connector or strap.

Over-driven Nails in Connectors and Straps

A nail that is installed such that the head deforms the steel of the connector or strap is considered over-driven. Extra care to prevent over-driven nails should be taken when installing power-driven nails. Simpson Strong-Tie has evaluated the effect of over-driven nails in connectors and straps. No load reductions for connectors or straps apply as a result of over-driven nails if all of the following conditions are met:

- Connectors and straps are 14-, 16-, or 18-gauge steel.
- The top of the nail head is not driven past flush with the face of the metal hardware.
- The nail goes through an existing fastener hole without enlarging it.
- The steel around the hole is not torn or damaged other than denting caused by the nail head.

Load Tables, Technical Data and Installation Instructions

Wafer-Head Screw

General Wood-to-Wood Fastening

For more information, see page 80

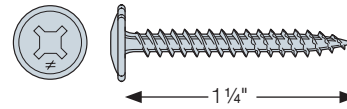

Allowable Loads

Model No.	Size (in.)	Allowable Shear Loads (lbs.)		Allowable Withdrawal Loads (lbs.)	
		Steel Side Plate Thickness, in. (ga)			
		0.054 – 0.25 (16-3)		DF/SP	SPF/HF
		DF/SP	SPF/HF		
SD8x1.25	5/32 x 1 1/4	50	45	82	58

1. Allowable loads are shown at the wood load duration factor of $C_D = 1.00$. Loads may be increased for load duration up to a $C_D = 1.60$.
2. SD8x1.25 requires 3/4" minimum penetration into the main member. DO NOT USE SD8x1.25 wood screws with structural connectors unless specified. WARNING: Industry studies show that hardened fasteners can experience performance problems in wet or corrosive environments. Accordingly, use this product in dry, interior, and noncorrosive environments only.

Load Tables, Technical Data and Installation Instructions

EB-TY® Hidden Deck Fasteners



Installation Information

- As with all decking materials, please consult manufacturer's installation instructions for deck height requirements and deck board spacing.
- All slots for the EB-TY's (*except for the 316TT*) can be cut using a #20 setting with a biscuit cutter/plate joiner or router with $\frac{5}{16}$ " slot cutter. Decking can be grooved the entire length of the board.
- Always butt boards over a joist. One method for installing butt ends is to cut the keel off the bottom of an EB-TY, slot the board ends, and insert the EB-TY. Another, more reliable method is to face-screw and plug.

If you have questions about which EB-TY to use, contact Simpson Strong-Tie.

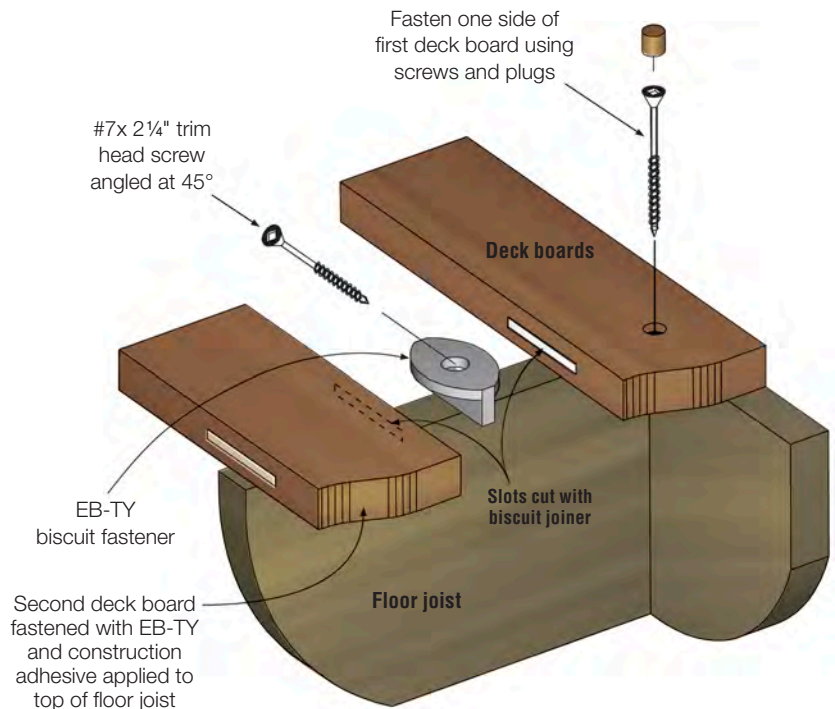

Installation Process For Wood

1. Fasten the first board using construction adhesive and screws, then cut slots where the board intersects joists using a $\frac{5}{16}$ " router bit or plate joiner (biscuit cutter #20) and install the first EB-TY fasteners. Cut slots in the next board where it intersects the joists.
2. Apply a bead of construction adhesive to the top of each joist and install the new board so that the slots fit over the EB-TY fasteners installed in the first board.



Construction adhesive is not recommended when installing composite deck boards as some adhesives will have an adverse reaction upon contact with certain plastics.

3. Insert EB-TY fasteners into each slot in the exposed edge of the board and fasten with screws.
4. Repeat the process until all boards are installed.

Refer to the installation instructions (*included*) for more information. Consult composite decking manufacturer's or wood supplier's installation instructions for deck height requirements and deck board spacing.

Pre-grooving the entire length of the deck board is a time-saving alternative to individual grooves made with a router or plate joiner. Some types of composite lumber are available with grooves as an added feature. Have your lumber yard use the schematic on the right to pregroove boards to accept EB-TY fasteners.

**For model numbers TP015 and 316TT screws are to be driven at a 90° angle to the board face.*

Bring the schematic below to your lumber yard. They will use it to pre-groove your decking material to accept EB-TY fasteners.

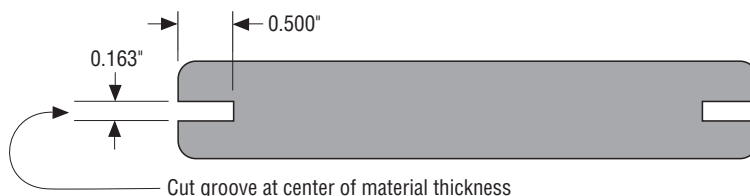

Load Tables, Technical Data and Installation Instructions

Self-Drilling E Metal Screw

Common Application:

Cold-formed steel framing

- Recommended for use with certain Simpson Strong-Tie® connectors
- #3 drill point (Max. total drilling thickness 0.35")

Codes/Standards: ASTM C1513 compliant

For More Product Information, see page 124

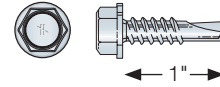

E – Screw Strength

Screw Size	Model No.	Nominal Strength (lbs.)		Design Strength (LRFD) (lbs.) $\phi = 0.5$		Allowable Strength (ASD) (lbs.) $\Omega = 3.0$	
		P_{ss}	P_{ts}	ϕP_{ss}	ϕP_{ts}	P_{ss}/Ω	P_{ts}/Ω
#14 x 1"	E1B1414	3130	5395	1565	2700	1045	1800

E – Cold-Formed Steel Member Connection Loads, Steel to Steel

Screw Size	Model No.	Nominal Dia. (in.)	Washer Dia. (in.)	Load Description	Shear (lbs.)					Pull-Over (lbs.)					Pull-Out (lbs.)				
					Steel Thickness: mil (ga.)					Steel Thickness: mil (ga.)					Steel Thickness: mil (ga.)				
					33 (20)	43 (18)	54 (16)	68 (14)	97 (12)	33 (20)	43 (18)	54 (16)	68 (14)	97 (12)	33 (20)	43 (18)	54 (16)	68 (14)	97 (12)
#14 x 1"	E1B1414	0.242	0.5	ASD	200	295	605	850	1045	390	505	920	1160	1655	105	140	250	320	455
				LRFD	300	445	905	1280	1565	585	760	1380	1740	2480	160	210	380	480	680
				Nominal Strength	600	890	1810	2555	3130	1170	1520	2760	3475	4960	320	415	755	955	1360

1. Screws shall extend through the connection with a minimum of 3 exposed threads per AISI General Provisions Standard Section D1.3.
2. Tabulated loads are based on calculations per AISI S100-07 using the thinner steel member in the connection. A safety factor of $\Omega = 3.0$ and resistance factor $\phi = 0.5$ were used to determine the ASD and LRFD strength values.

3. Loads are based on cold-formed steel members with a minimum yield strength, F_y , of 33 ksi and tensile strength, F_u , of 45 ksi for 43 mils (18 ga.) and thinner, and a minimum yield strength of 50 ksi and tensile strength of 65 ksi for 54 mils (16 ga.) and thicker.
4. For other pertinent information, please refer to the Important Information and General Notes pages in the current Simpson Strong-Tie® *Cold-Formed Steel Connectors for Residential and Mid-Rise Construction* catalog.

Load Tables, Technical Data and Installation Instructions

PC/PCSD/PCULP Screws

Cold-Formed Steel (CFS) Member Connection Loads

Model	Model No.	Size	Nominal Dia. ⁷ (in.)	Load Description	Shear (lbs.)						Pull-Over (lbs.)						Pull-Out (lbs.)						
					Steel Thickness: mil (ga) ⁶						Steel Thickness: mil (ga) ⁶						Steel Thickness: mil (ga) ⁶						
					27	33	43	54	68	97	27	33	43	54	68	97	22	27	33	43	54	68	97
(22)	(20)	(18)	(16)	(14)	(12)	(22)	(20)	(18)	(16)	(14)	(12)	(24)	(22)	(20)	(18)	(16)	(14)	(12)					
Pancake Head Screw – Metal Roofing-to-Steel																							
PCSD	PCSD1S1016	#10-16x1"	0.190	ASD ²	168	250	385	570	570	570	172	255	430	—	—	—	67	68	95	138	255	310	—
				Nominal Load ⁴	420	570	875	1475	1645	1690	420	735	1220	—	—	—	171	166	235	340	630	760	—
PCSD	PCSD1S1214	#12-14x1"	0.216	ASD ²	156	295	420	585	585	585	210	320	505	—	—	—	66	66	88	129	255	320	—
				Nominal Load ⁴	400	695	955	1640	1890	2290	520	780	1245	—	—	—	170	162	240	315	625	785	—
Pancake Head Screw – Metal Roofing-to-Wood (or light gauge CFS)																							
PC	PC1BS1012	#10-12x1"	0.190	ASD ²	290	345	—	—	—	—	170	255	475	—	—	—	106	136	—	—	—	—	—
				Nominal Load ⁴	660	785	—	—	—	—	475	765	1195	—	—	—	265	335	—	—	—	—	—
PC	PC1BS1211	#12-11x1"	0.216	ASD ²	320	390	—	—	—	—	200	300	450	—	—	—	113	151	—	—	—	—	—
				Nominal Load ⁴	725	880	—	—	—	—	505	735	1100	—	—	—	280	370	—	—	—	—	—
Ultra Low Profile Pancake Head Screw – Metal Roofing-to-Wood																							
PCULP	PCULP1BS1012	#10-12x1"	0.190	ASD ²	—	—	—	—	—	—	180	285	505	—	—	—	—	—	—	—	—	—	—
				Nominal Load ⁴	—	—	—	—	—	—	445	810	1240	—	—	—	—	—	—	—	—	—	—

- Screws and screw connections have been tested per AISI Standard Test Method S904-08 and S905-08.
- The tabulated ASD loads for cold-formed steel (CFS) members are based on the lower of the screw strength or the strength of the screw in the connected members per AISI S100-07 Section E4.
- The safety factor is based on AISI S100-07 Chapter F for tested connections.
- The nominal load values listed are achieved under laboratory conditions and should not be used for design loads.
- Values are based on CFS members with a minimum yield strength of $F_y = 33$ ksi and tensile strength of $F_u = 45$ ksi for 43 mil (18 ga) to 27 mil (22 ga), minimum yield strength of $F_y = 50$ ksi and tensile strength of $F_u = 65$ ksi for 22 mil (24 ga), and a minimum yield strength of $F_y = 50$ ksi and $F_u = 65$ ksi for 54 mil (16 ga) and thicker.
- For design purposes, steel sheet thicknesses are 0.0227" for 22 mil, 0.283" for 27 mil, 0.0346" for 33 mil, 0.0451" for 43 mil, 0.0566" for 54 mil, 0.0713" for 68 mil, and 0.1017" for 97 mil. The actual sheet thickness shall not be less than 95% of these design thickness as specified in AISI S100-07 Section A2.4.
- Screw diameters per AISI S200-07 General Provision Commentary Table D1.1.
- Minimum required screw length is the lesser of 3/4" or the minimum length required for the screw to extend through the steel connection a minimum of 3 exposed threads per AISI S200-07 General Provisions Standard Section D1.3.
- Larger of screw head or washer diameter, d_w , for #10 and #12 screws is 0.375".
- The allowable load (ASD) values shown are not permitted to be increased for short-duration loads such as wind or earthquake loads.
- The lower of the Pull-Over and Pull-Out allowable load should be used for tension design.
- The tabulated shear values are based on the thinner steel member in connection. Steel thickness for both members must be in the range of 12-22 gauge.

Wood Member Connection Withdrawal Loads

Model	Model No.	Size	Nominal Diameter ⁵ (in.)	Load Description	Withdrawal (lbs.)					
					Plywood			OSB		SYP
					1/2"	5/8"	3/4"	7/16"	3/4"	2x
Pancake Head Screw – Metal Roofing to Wood										
PC	PC1BS1012	#10-12x1"	0.190	Allowable Load ^{1,2}	55	55	60	33	51	117
				Average Ultimate Load ³	275	275	300	165	255	585
PC	PC1BS1211	#12-11x1"	0.216	Allowable Load ^{1,2}	55	62	62	39	51	117
				Average Ultimate Load ³	275	310	310	194	255	585
Ultra Low Profile Pancake Head Screw – Metal Roofing to Wood										
PCULP	PCULP1BS1012	#10-12x1"	0.190	Allowable Load ^{1,2}	55	55	55	39	39	105
				Average Ultimate Load ³	275	275	275	194	194	525

- Values based on the lower screw strength or strength of the screw in the connected members.
- The tabulated allowable loads for wood members are based on factor of safety of 5 as specified in AC233, and $C_D=1.0$. Values may be multiplied by $C_D=1.6$ for wind or earthquake.
- The average ultimate loads are achieved under laboratory conditions and should not be used for design purposes.
- Screw diameters per AISI S200-07 General Provisions Commentary Table D1-1.
- See page 271 for information on screw strength.

Load Tables, Technical Data and Installation Instructions

PCSD Standing-Seam Roofing Panel Clip Screw

PCSD (#10) Screw – (Sheet Steel Sheathing to CFS)

Nominal Shear Strength (R_n) for Wind (W) and Seismic (S) for Shear Walls¹ (lbs./ft.)^{1,4,6,8}

Assembly Description	Max. Aspect Ratio (h/w)	Fastener Spacing at Panel Edges ² (in.)				Designation Thickness ⁵ of Stud, Track and Blocking ⁷ (mils)
		6	4	3	2	
0.018" sheet steel, one side	2:1	485 (W) 390 (S)	—	—	—	33 (min.)
0.027" sheet steel, one side	4:1	—	1000	1085	1170	43 (min.)
	2:1 ³	647	710	778	845	33 (min.)
0.018" sheet steel, both sides	2:1	970 (W) 780 (S)	—	—	—	33 (min.)
0.027" sheet steel, both sides	4:1	—	2000	2170	2340	43 (min.)
	2:1 ³	1294	1420	1556	1690	33 (min.)

- Nominal strength shall be multiplied by the resistance factor ($\phi = 0.6$, LRFD Seismic, $\phi = 0.65$, LRFD Wind) to determine design strength or divided by the safety factor ($\Omega = 2.5$, ASD Seismic, $\Omega = 2.0$, ASD Wind) to determine allowable strength.
- Screws in the field of the panel shall be installed 12" (305 mm) on center (o.c.).
- Shear wall height to width aspect ratio (h/w) greater than 2:1, but not exceeding 4:1, shall be permitted provided the nominal strength values are multiplied by 2w/h.
- Wall studs and track shall be of ASTM A1003 Structural Grade 33 (Grade 230) Type H steel for members with a designation thickness of 33 and 43 mils.

- In lieu of blocking, panel edges shall be permitted to be overlapped and attached to each other with screw spacing as required for panel edges. Where such a connection is used, tabulated design values shall be reduced 30%.
- Maximum stud spacing 24" o.c.
- Blocking, if applicable, shall be a minimum 33 mil 1½" width.
- Table based on Table C2.1-1 AISI Standard "North American Standard for Cold-Form Steel Framing-Lateral Design 2007 Edition with Supplement No. 1 and Commentary".

DWF/DWFSD Screws

Nominal Shear Strength (R_n) for Wind and Seismic Loads Shear Walls (Wind and Seismic Loads) Faced with ½" Gypsum Board (lbs./ft.)¹⁻⁶

Assembly Description	Max. Aspect Ratio (h/w)	Fastener Spacing at Panel Edges/Field (in.)			
		7/7	4/4	4/12	8/12
½" gypsum board on one side of wall; steel studs max. 24" o.c.	2:1	290	425	295	230

- Nominal strength shall be multiplied by the resistance factor ($\phi = 0.6$ LRFD Seismic, $\phi = 0.65$ LRFD Wind) to determine design strength or divided by the safety factor ($\Omega = 2.5$ ASD Seismic, $\Omega = 2.0$ ASD Wind) to determine allowable strength.
- For gypsum sheathed shear walls, tabulated values shall be applicable for short-term load duration only (wind or seismic loads).
- Gypsum board shall comply with ASTM C1396.

- Gypsum Board shall be applied horizontal with 33 mil strap blocking of 1½" width. In addition, solid blocking is required between the first two end studs. Alternatively, sheets may be applied vertically or values can be multiplied by 0.35.
- Studs and track shall be a minimum thickness of 33 mils.
- Table based on Table C2.1-2 AISI Standard "North American Standard for Cold-Form Steel Framing-Lateral Design 2007 Edition with Supplement No. 1 and Commentary".

Load Tables, Technical Data and Installation Instructions

PPSD/CBSDQ/FHSD/WSFLRV Screws

For More Product Information,

- Strong-Drive® PPSD Sheathing-to-CFS screw: see pages 123, 196
- CBSAQ Sheathing Screw: see page 199
- FHSD Wood-to-CFS screw: see page 201
- WSFLRV Wood-to-CFS/Aluminum screw: see page 201

PPSD, CBSAQ, FHSD, WSFLRV Screw¹¹ – Nominal Shear Strength (R_n) for Wind and Other In-Plane Loads for Shear Wall^{1,4,6} (lbs./ft.)

Assemble Description	Maximum Aspect Ratio (h/w)	Fastener Spacing at Panel Edges (in.)			
		6	4	3	2
1½" structural 1 sheathing (4-ply), one side	2:1	1065 ³	—	—	—
7/16" rated sheathing (OSB), one side	2:1	910 ³	1410	1735	1910
7/16" rated sheathing (OSB), one side oriented perpendicular to framing	2:1	1020	—	—	—
7/16" rated sheathing (OSB), one side	2:1 ⁵	—	1025	1425	1825

- Nominal strength shall be multiplied by the resistance factor ($\phi = 0.65$) to determine the design strength or divided by the safety factor ($\Omega = 2.0$) to determine the allowable strength.
- Screws in the field of the panel shall be installed 12" (305 mm) on center (o.c.).
- Where fully blocked gypsum board is applied to the opposite side of this assembly, per Table C2.1-2 AISI Standard "North American Standard for Cold-Formed Steel Framing - Lateral Design 2007 Edition with Supplement No. 1 and Commentary" with screw spacing at 7" (178 mm) o.c. edge and 7" (178 mm) o.c. field, these nominal strengths are permitted to be increased by 30%.
- For walls with material of the same type and nominal strength applied to opposite faces of the same wall, the available strength of material of same capacity is cumulative. Where the material nominal strengths are not equal, the available strength shall be either two times the available strength of the material with the smaller value or shall be taken as the value of the stronger side, whichever is greater. Summing the available strengths of dissimilar material applied to opposite faces or to the same wall line is not allowed.
- Shear wall height to width aspect ratio (h/w) greater than 2:1, but not exceeding 4:1, shall be permitted provided the nominal shear strength is multiplied by 2w/h.
- For wood structural panel sheathed shear walls, tabulated R_n values shall be applicable for short-term load duration (wind loads). For other in-plane lateral loads of normal or permanent load duration as defined by the AWC NDS, the values in the table above for wood structural panel sheathed shear walls shall be multiplied by 0.63 (normal) or 0.56 (permanent).
- Maximum stud spacing 24" o.c.
- All sheathing edges shall be attached to framing or 1½" width 33 mil blocking.
- Table based on Table C2.1-1 AISI Standard "North American Standard for Cold-Form Steel Framing - Lateral Design 2007 Edition with Supplement No. 1 and Commentary".
- See General Load Table on page 271 for screw strength.
- #8 screws – PPSD, CBSAQ, FHSD, WSFLRV. #10 screws – FHSD.
- Stud, track and blocking (if applicable) shall be a minimum of 33 mils.

PPSD, CBSAQ, FHSD, WSFLRV Screw¹² – Nominal Shear Strength (R_n) for Seismic and Other In-Plane Loads for Shear Wall^{1,4,7} (lbs./ft.)

Assemble Description	Maximum Aspect Ratio (h/w)	Fastener Spacing at Panel Edges ² (in.)				Designation Thickness ^{5,6} of Stud, track and Blocking (mils)	Required Sheathing Screw Size
		6	4	3	2		
1½" structural 1 sheathing (4-ply), one side	2:1 ³	780	990	—	—	33 or 43	8
	2:1	890	1330	1775	2190	43 or 54 68	8 10
7/16" rated sheathing (OSB), one side	2:1 ³	700	915	—	—	33	8
	2:1 ³	825	1235	1545	2060	43 or 54	8
	2:1	940	1410	1760	2350	54	8
	2:1	1232	1848	2310	3080	68	10

- Nominal strength shall be multiplied by the resistance factor ($\phi = 0.60$) to determine the design strength or divided by the safety factor ($\Omega = 2.5$) to determine the allowable strength.
- Screws in the field of the panel shall be installed 12" (305 mm) on center (o.c.).
- Shear wall height to width aspect ratio (h/w) greater than 2:1, but not exceeding 4:1, shall be permitted provided the nominal shear strength is multiplied by 2w/h.
- For walls with material of the same type and nominal strength applied to opposite faces of the same wall, the available strength of material of same capacity is cumulative. Where the material nominal strengths are not equal, the available strength shall be either two times the available strength of the material with the smaller value or shall be taken as the value of the stronger side, whichever is greater. Summing the available strengths of dissimilar material applied to opposite faces or to the same wall line is not allowed.
- Substitution of a stud or track of a different designation thickness is not permitted.
- Wall studs and track shall be of ASTM A1003 Structural Grade 33 (Grade 230) Type H steel for members with a designation thickness of 33 and 43 mils, and A1003 Structural Grade 50 (Grade 340) Type H steel for members with a designation thickness equal to greater than 54 mils.
- For wood structural panel sheathed shear walls, tabulated R_n values shall be applicable for short-term load duration (seismic loads). For other in-plane lateral loads of normal or permanent load duration as defined by the AF&PA NDS, the values in the table above for wood structural panel sheathed shear walls shall be multiplied by 0.63 (normal) or 0.56 (permanent).
- Maximum stud spacing 24" o.c.
- All sheathing edges shall be attached to framing or 1½" width 33 mil blocking.
- Table based on Table C2.1-3 AISI Standard "North American Standard for Cold-Formed Steel Framing - Lateral Design 2007 Edition with Supplement No. 1 and Commentary".
- See General Load Table on page 271 for screw strength.
- #8 screws – PPSD, CBSAQ, FHSD, WSFLRV. #10 screws – FHSD.

Load Tables, Technical Data and Installation Instructions

Self-Drilling X Metal Screw

Common Application:

Steel decking-to-structural steel cold-formed steel framing and steel stitching

Codes/Standards: ICC-ES ESR-3006 (only those marked *), City of LA RR25670 and RR25917, ASTM C1513 compliant, FM Approval #3045651, SDI DDM03, Appendix VII, IAPMO-UES ER-326

For More Product Information, see pages 125, 197

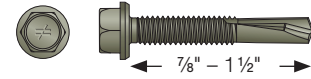

X – Cold-Formed Steel Connection Loads

Model No.	Size	Nominal Dia. (in.) ⁸	Load Description	Shear (lbs.)								Pull-Over (lbs.)						Pull-Out (lbs.)								
				Steel Thickness: mil (ga)								Steel Thickness: mil (ga)						Steel Thickness: mil (ga)								
				27	33	43	54	68	97	1/8" 12	1/4" 12	27	33	43	54	68	97	27	33	43	54	68	97	3/16"	1/4"	1/2" 12
(22)	(20)	(18)	(16)	(14)	(12)			(22)	(20)	(18)	(16)	(14)	(12)	(22)	(20)	(18)	(16)	(14)	(12)							
XQ1S1016 X1S1016	#10-16x1"	0.190	ASD	194	240	360	540	540	540	—	—	330	400	475	645	925	975	71	87	129	200	270	445	—	—	—
			LRFD	310	385	570	810	810	810	—	—	525	640	755	1035	1475	1465	114	139	205	320	430	715	—	—	—
			Nominal Strength	440	550	815	1290	1290	1290	—	—	805	990	1160	1585	2260	2695	174	215	315	490	660	1095	—	—	—
XQ1S1214 X1S1214	#12-14x1"	0.216	ASD	176	235	385	595	840	840	—	—	295	375	525	785	1045	1210	74	96	147	215	325	500	—	—	—
			LRFD	280	375	610	950	1265	1265	—	—	470	600	835	1255	1675	1930	117	154	235	340	520	795	—	—	—
			Nominal Strength	400	535	870	1350	2135	2135	—	—	720	920	1285	1925	2565	2965	180	235	360	520	800	1220	—	—	—
XQ78S1224*	#12-24x7/8"	0.216	ASD	140	230	350	640	740	935	935	935	265	290	400	720	790	1390	78	80	115	200	260	460	730	1375	1420
LRFD	210		365	560	1025	1175	1355	1355	1355	395	440	640	1155	1260	2160	117	125	185	320	415	735	1170	2135	2160		
Nominal Strength	420		550	920	1455	1675	2675	2675	2675	795	875	985	1770	1930	3400	235	205	280	505	640	1130	1990	3370	4260		
XQ114S1224*	#12-24x1 1/4"	0.216	Nominal Strength	420	550	920	1455	1675	2675	2675	795	875	985	1770	1930	3400	235	205	280	505	640	1130	1990	3370	4260	
XQ112S1224*	#12-24x1 1/2"			420	550	920	1455	1675	2675	2675	795	875	985	1770	1930	3400	235	205	280	505	640	1130	1990	3370	4260	

1. Screws and screw connections have been tested per AISI Standard Test Method S904-08 and S905-08 with the exception of 22 gauge values which are based on calculations of the AISI S100-07 Section E4.
2. The tabulated ASD and LRFD allowable loads for cold-formed steel (CFS) members are based on the lower of the screw strength or the strength of the screw in the connected members per AISI S100-07.
3. The safety factor Ω and resistance factor ϕ used to determine the ASD and LRFD strength are based on AISI S100-2007 Section F.
4. The nominal strength values listed are achieved under laboratory conditions and should not be used for design loads.
5. Values are based on CFS members with a minimum yield strength of $F_y = 33$ ksi and tensile strength of $F_u = 45$ ksi for 43 mil (18 ga) to 27 mil (22 ga), minimum yield strength of $F_y = 50$ ksi and $F_u = 65$ ksi for 54 mil (16 ga) to 97 mil (12 ga), and a minimum yield strength of $F_y = 36$ ksi and $F_u = 58$ ksi for 1/8" and thicker.
6. For design purposes, steel sheet thicknesses are 0.0283" for 27 mil, 0.0346" for 33 mil, 0.0451" for 43 mil, 0.0566" for 54 mil, 0.0713" for 68 mil, and 0.1017" for 97 mil. The actual sheet thickness shall not be less than 95% of these design thickness as specified in AISI S100-7 Section A2.4.

7. Screw diameters per AISI S207-07 General Provisions Commentary Table D1-1.
8. Minimum required screw length is the lesser of 3/4" or the minimum length required for the screw to extend through the steel connection a minimum of 3 exposed threads per 2004 AISI General Provisions Standard section D1.3.
9. Screw head or washer diameter, dw for #10 and #12 screws is 0.398".
10. The allowable load (ASD) values showing are not permitted to be increased for short duration loads such as wind or earthquake loads.
11. The lower of the pull-over and pull-out allowable load should be used for tension design.
12. Not applicable for XQ78S1224.
13. The tabulated shear values are based on the thinner steel member in connection. Steel thickness for both member must be in the range of 1/2" - 22 gauge.
14. The XQ-S1224 screws are recommended for 16 gauge and thicker steel
15. See page 271 for information on screw strength.

Load Tables, Technical Data and Installation Instructions

Steel-Deck Fastening

Steel decks may be classified into roof decks, form decks and composite decks. For the system to conform to the Steel Deck Institute (SDI) design practice, it is assumed that the steel deck is fastened to a steel supporting structure. The primary purpose of these decks is to support vertical loads, but they can also be used as a horizontal diaphragm to resist lateral loads from wind or earthquake forces. The strength of the diaphragm can be limited by fastener connection strength, local panel buckling, or even plate buckling of the entire diaphragm.

Steel-deck panels are available in different geometries and thicknesses and steel properties from different manufacturers. Common deck panel profiles are narrow rib (NR, commonly referred to as Type A deck), intermediate rib (IR, commonly referred to as Type F deck) and wide rib (WR, commonly referred to as Type B deck). Illustrations of these can be found in SDI publications. The SDI design recommendations are limited to deck panels that are in the thickness range of 0.014 in. to 0.064 in., and panel depths $\frac{5}{16}$ in. to 3 in.

Steel-deck fastening is categorized into two groups – structural fastening and side lap or stitch fastening. Structural fasteners connect the steel deck panels to the structural framing, while side lap fasteners connect the panels together along the free edges between the supports. The most important information for any steel deck fastener is the connection strength and connection flexibility that is developed using the fastener.

Steel-Deck Fastening

Based on the deck profile, width and the design load, a structural fastening pattern and the number of side-lap fasteners or side-lap spacing can be determined. The fastening pattern provides the number of structural fasteners needed to attach the decking panel to support steel. The structural fastening pattern is given by the deck width followed by the number of fasteners. e.g., 36/7 pattern means 36" wide panel attached with 7 fasteners. The most typical fastener patterns for steel deck profiles are shown here.

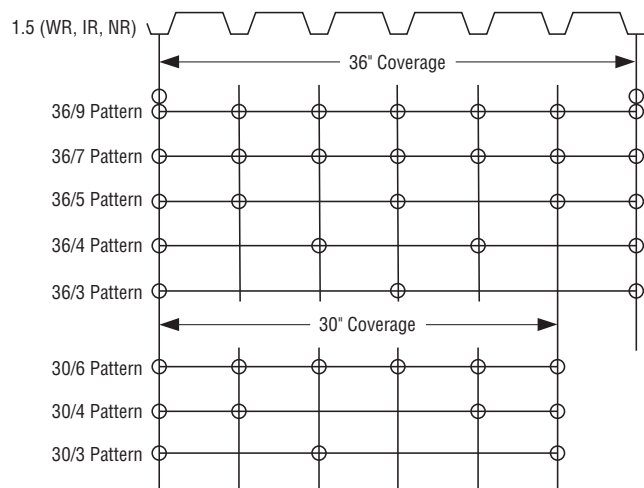

Typical Fastener Layout

(From SDI, DDM03, 2004, 3rd Edition, Appendix IV.)

The number of side-lap fasteners required at the over-lapping panel edges are per deck span between structural supports. For example, five side laps for a 6-ft deck span would represent six even spaces with side-lap fasteners at 12" on center. The side-lap fastener spacing can range between 3" and 36" o.c.

Structural fastening can be done with puddle welds, power-actuated pins, or screws. Each type of fastening has its advantages and disadvantages in terms of installation cost, installation effort, capacity, energy dissipation and behavior at ultimate load. All of the fasteners would be called out in a fastener pattern using the nomenclature shown in the figure.

Load Tables, Technical Data and Installation Instructions

Steel-Deck Fastening (cont.)

Evaluation Reports and Approvals

Steel-deck diaphragms can be designed and constructed following code recognized design procedures and provisions. At the same time, the codes provide for alternate design methods and materials to be recognized by the authority having jurisdiction. Some deck and fastener manufacturers have gone the alternate route and in that process have secured evaluation reports that can be used by the engineering design community for design of steel diaphragms and by the local building officials as the basis for approval. ICC-ES and IAPMO UES provide criteria that can be used to secure evaluation reports for steel diaphragm products.

The insurance industry also has a form of compliance that it uses as the basis for risk management. Factory Mutual (FM) provides an Approval for deck products and systems as well as fasteners used for fastening the deck panels.

Simpson Strong-Tie Steel-Deck Fasteners

Simpson Strong-Tie holds evaluation reports and FM Approvals for all of its steel deck diaphragm fasteners. These reports and approvals are available on line at no-cost from the issuing agency or at www.strongtie.com.

The Simpson Strong-Tie self-tapping X-series metal screws have been qualified for compliance with ASTM C1513 and some of these screws are included in the SDI, DDM03, Appendix VII. In that document, diaphragm design values are provided in tabular format for typical fastening patterns and for a range of common deck thicknesses. The SDI DDM03 Manual is a code referenced document.

In addition, the strength and flexibility of connections with Simpson Strong-Tie X-series screws used in steel decks were evaluated per IAPMO UES Evaluation Criteria EC007 (2013), which is based on AISI S310, North American Standard for the Design of Profiled Steel Panels. The connection strengths and flexibilities can be used to calculate the nominal diaphragm shear strength and diaphragm stiffness per Sections 2 and 3 of SDI DDM03.

The Simpson Strong-Tie steel deck diaphragm calculator, which is available as a web app, can be used to do the diaphragm strength and stiffness calculations, investigate alternative fastening strategies and ultimately produce the required submission documents.

The available Simpson Strong-Tie fasteners for steel-deck applications are listed on pages 125 and 197 of this catalog. They are available in bulk or collated forms. The collated forms are driven using Quik Drive® Systems. For more up-to-date information on steel diaphragm fasteners, evaluation reports, approvals and appropriate Quik Drive tools including some products not found in the print catalog, see www.strongtie.com.

Save Time with our Steel Deck Diaphragm Calculator

Generate diaphragm shear tables for various roof and floor decks attached using Simpson Strong-Tie® X-series screws. Create shear strength tables in Nominal, ASD or LRFD for various deck spans. The tables are calculated based on Steel Deck Institute (SDI) Diaphragm Design Manual, Third Edition (DDM03). The factors of safety are based on Table D5 of AISI S100, North American Specification for the Design of Cold-formed Steel Members.

- Requires minimal input to generate the tables
- Generate tables for any Simpson support or side lap fastener combination.
- Create custom table with any support fastener pattern chosen
- Accounts for wind uplift demand
- Choose the first deck span in the table; total of 10 deck spans are shown in increments of 6 in. from the minimum span chosen.
- Produce custom tables for floor decks with any typical fill type
- Generate tables in Nominal, ASD Wind, LRFD Wind, or LRFD EQ or ASD EQ.



strongtie.com/diaphragmcalc

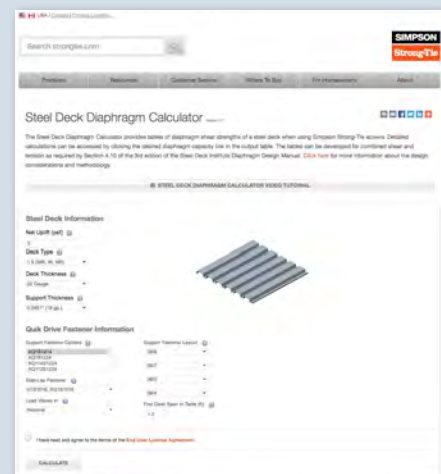

Stainless-Steel Fasteners



Stainless-Steel Fasteners

Screws

Strong-Drive®
SDWH **TIMBER HEX SS** Screw

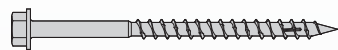

Page 60

Composi-Lok™
Composite-Decking Screw



Page 76

Dexxter™
Composite-Decking Screw



Pages 74-75

Deck-Drive™
DWP **WOOD SS** Screw



Pages 64-65

Bugle-Head Wood
Decking Screw:
6-Lobe Drive



Page 67

Bugle-Head Wood Decking
Screw: Square Drive

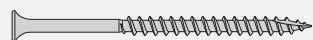

Pages 68-69

Trim-Head Decking Screw:
Square Drive



Pages 70-71

Trim-Head Decking Screw:
6-lobe Drive

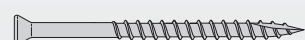

Pages 72-73

Nails

Strong-Drive®
SCNR **RING-SHANK CONNECTOR** Nail



Page 102

Premium Siding Nail



Page 81

Premium Common Nail



Page 81

Box Nail – Annular Ring Shank



Page 82

Cedar and Redwood
Decking Nail



Page 83

Wood Siding Nail



Page 84

Common Nail – Annular
Ring Shank

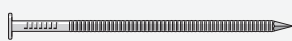

Page 85

Common Nail – Smooth Shank

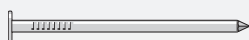

Page 86

Fencing Nail



Page 87

Fiber-Cement Siding Nail

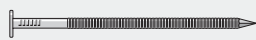

Page 87

Finishing Nail

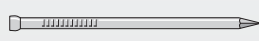

Page 88

Nail with EPDM Washer –
Annular Ring Shank



Page 89

Nail with EPDM Washer –
Spiral Shank



Page 89

Preservative-Treated
Wood Decking Nail



Page 91

Pyramid-Head Nail



Page 92

Roofing Nail – Annular Ring Shank



Pages 97-98

Painted Siding Nail



Pages 93-94

Post and Beam Nail –
Annular Ring Shank



Page 90

Roofing Nail – Smooth Shank

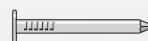

Page 99

Shake and Shingle
Siding/Roofing Nail



Page 95

Tile/Slating Nail –
Annular Ring Shank

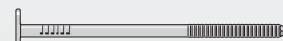

Page 100

Tile/Slating Nail – Smooth Shank

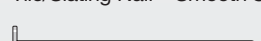

Page 101

Washed Roofing Nail

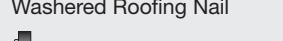

Page 96

Stainless-Steel Fasteners

Specialty

Escutcheon Pins



Page 104

Fencing Staples



Page 105

Fiber-Cement Screw



Page 109

Metal Panel Screw

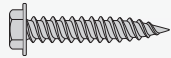

Page 110

Metal Panel Screw with EPDM Washer



Page 110

Hog Ring – #3 Pre-Bent, Hill Pattern



Page 105

Hog Ring – Blair Shaped



Page 105

Marine Screw – Pan Head



Page 106

Marine Screw – Flat Head

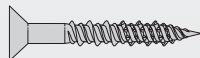

Page 107

Marine Screw – Oval Head

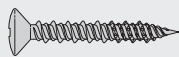

Page 108

Pocket-Hole Screw

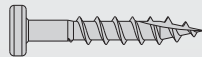

Page 117

Washers for Nail and Screw Assemblies

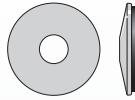

Page 119

Storm-Panel Screw

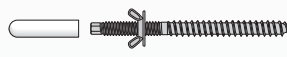

Page 118

Trim-Head Screw with Sealing Washer

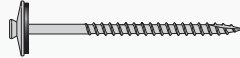

Page 115

Truss-Head Screw

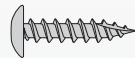

Page 116

Wire-Lath Modified Truss-Head Screw



Page 115

Inserted Plastic-Coil Nails

0° Inserted Plastic Coil, Full Round Head, Ring-Shank Nail



Page 136

15° Inserted Plastic Coil, Full Round Head, Ring-Shank Nail



Pages 137-138

Wire-Coil Nails

15° Wire Coil, Full Round Head Ring-Shank Siding Nail



Page 139

15° Wire Coil, Painted Full Round Head, Ring-Shank Nail



Page 140

15° Wire Coil, Full Round Head, Ring-Shank Roofing Nail



Page 141

15° Wire Coil, Full Round Head Smooth-Shank Roofing Nail

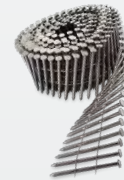

Page 142

Stainless-Steel Fasteners

15° Wire Coil, Full Round Head, Ring-Shank Decking/Framing Nail



Page 143

15° Wire Coil, Painted Full Round Head Ring-Shank Decking/Framing Nail



Page 144

20-22° Plastic Strip, Full Round Head, Smooth-Shank Nail

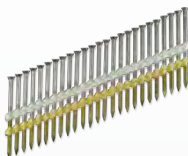

Page 148

31-34° Plastic Strip, Full Round Head, Ring-Shank Nail



Page 149

Plastic-Strip Nails

20-22° Plastic Strip, Casing Head, Ring-Shank Nail

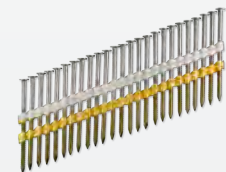

Page 145

20-22° Plastic Strip, Full Round Head, Ring-Shank Nail

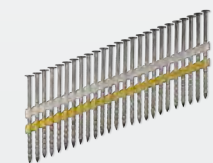

Page 146

20-22° Plastic Strip, Full Round Head, Screw-Shank Nail

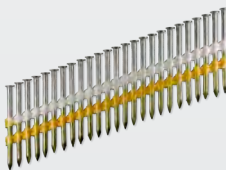

Page 147

Paper-Tape Nails

31-34° Paper Tape, Clipped Head, Ring-Shank Nail

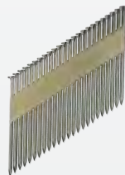

Page 151

Strong-Drive® 33° SCNR **RING-SHANK CONNECTOR** Nail

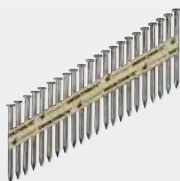

Page 152

33° Tape Collation, DA-Style Angle 15 Gauge Finishing Nail



Page 158

Adhesive Collation Nails

20° Angle Adhesive Collation, T-Style Head, 16 Gauge Finishing Nail



Page 153

25° Angle Adhesive Collation, FN-Style, 15 Gauge Finishing Nail

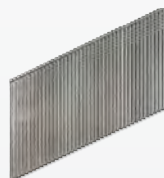

Page 154

Straight, Adhesive Collation, T-Style Head 16-Gauge Finishing Nail



Page 155

Straight, Adhesive Collation T-Style Head, 18-Gauge Brads



Page 156

Straight, Adhesive Collation 23-Gauge Micro Pins

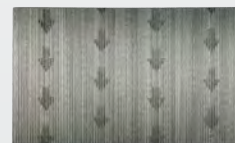

Page 157

Stainless-Steel Fasteners

Specialty

L Series Flooring Cleats



Page 159

T Series Flooring Cleats



Page 159

Collated Staples

1/2" Crown, 15 1/2 Gauge Staples
(Similar to Bostitch® "BCS" Series)

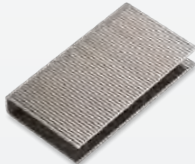

Page 160

1" Crown, 16 Gauge Staples
(Similar to Senco® "P" Series)

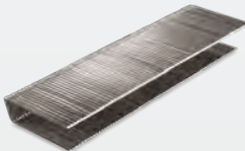

Page 160

1/2" Crown, 16 Gauge Staples
(Similar to Paslode® "GS" Series)

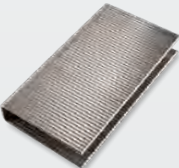

Page 161

1/4" Crown, 18 Gauge Staples
(Similar to Senco® "L" Series)



Page 162

7/16" Crown, 16 Gauge Staples
(Similar to Senco® "N" Series)

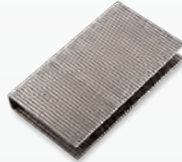

Page 163

3/8" Crown, 22 Gauge Staples
(Similar to Senco® "C" Series)



Page 164

Collated Screws for the Quik Drive® System

Deck-Drive™
DWP **WOOD SS** Screw



Page 174

Trim-Head Decking Screw:
Sharp Point



Page 176

SS3DSC Bugle-Head
Wood Decking Screw



Page 177

SSWSCB Roofing Tile Screw



Page 184

Alphabetical Index

0-9

8DHDGPT500.....	152
10D5HDG.....	103
10DHDG.....	103
16D5HDG.....	103
16DHDG.....	103
100-EBTYJR.....	120
100-EBTYLC.....	120
100-EBTYMI.....	120
100-EB TYS.....	120
175-EB162.....	120
175-EBAOSQ.....	120
175-EB TT.....	120
175-EBTYBG.....	120
175-EBTYJR.....	120
175-EBTYLC.....	120
175-EBTYMI.....	120
175-EBTYP.....	120
175-EB TYS.....	120
175-EB TYW.....	120
275-EBTYLC.....	120
275-EB TYS.....	120
316-TT.....	120
512050EP18.....	104
512075EP18.....	104
514075EP18.....	104
514100EP18.....	104
514125EP18.....	104
514150EP18.....	104
516037EP18.....	104
516050EP18.....	104
516062EP18.....	104
516075EP18.....	104
516100EP18.....	104
518037EP18.....	104
518050EP18.....	104
518075EP18.....	104
518100EP18.....	104

A

A12A187DNB.....	136
A12A225DNB.....	136
A21.....	323
A23.....	323
A33.....	323
A34.....	323
A35.....	323
A39ARN1.....	98
A39ARN5.....	98
A39ARNB.....	98
A39RN1.....	99
A39RN5.....	99
A39RNB.....	99
A44.....	323
A49ARN1.....	98
A49ARN5.....	98
A49ARNB.....	98
A49RN1.....	99
A49RN5.....	99
A49RNB.....	99
A69ARN1.....	98
A69ARN5.....	98
A69ARNB.....	98
A69RN1.....	99
A69RN5.....	99
A69RNB.....	99
A211ARN1.....	98
A211ARN5.....	98
A211ARNB.....	98
A211RN1.....	99
A211RN5.....	99
A211RNB.....	99
A311ARN1.....	98
A311ARN5.....	98

A311ARNB.....	98
A311RN1.....	99
A311RN5.....	99
A311RNB.....	99
A411ARN1.....	98
A411ARN5.....	98
A411ARNB.....	98
A411RN1.....	99
A411RN5.....	99
A411RNB.....	99
ABA44.....	323
ABA44R.....	323
ABA46.....	323
ABA46R.....	323
ABA66.....	323
ABA66R.....	323
ABU44.....	323
AC4.....	323
AC4R.....	323
AC6.....	323
AC6R.....	323

B

B12050EP18.....	104
B12075EP18.....	104
B14050EP1.....	104
B14050EP5.....	104
B14075EP1.....	104
B14100EP1.....	104
B14100EP5.....	104
B14125EP1.....	104
B14150EP1.....	104
B16050EP1.....	104
B16062EP1.....	104
B16075EP1.....	104
B16075EP5.....	104
B16100EP1.....	104
B16100EP5.....	104
B16125EP1.....	104
B16125EP5.....	104
B18050EP1.....	104
B18050EP18.....	104
B18075EP1.....	104
B18075EP18.....	104
B18100EP1.....	104
B18100EP18.....	104
BC4.....	323
BC40.....	323
BC60.....	323
BCS2-2/4.....	323
BIT1S-2-RC3.....	133
BIT2P.....	264
BIT2P-RC3.....	264
BIT2P-RC10.....	264
BIT2S.....	264
BIT2S-2-RC3.....	133
BIT2S-RC3.....	264
BIT2S-RC10.....	264
BIT2SU.....	264
BIT2SU-2-RC3.....	133
BIT2SU-RC3.....	264
BIT2SU-RC10.....	264
BIT3S.....	264
BIT3S-2-RC3.....	133
BIT3S-RC3.....	264
BIT3S-RC10.....	264
BIT3SU.....	264
BIT3SU-2-RC3.....	133
BIT3SU-RC3.....	264
BIT3SU-RC10.....	264
BIT15T-2-RC3.....	133
BIT20T-2-RC3.....	133
BIT25T-2-RC3.....	133
BIT27T-2-RC3.....	133
BIT30T-2-RC3.....	133

BIT40T-1-RC3.....	133
BIT40T-134-RC3.....	133
BITHEX516.....	264
BITHEXLB14.....	253, 264
BITHEXLB516.....	264
BITHEXLB516LG.....	247, 256, 264
BITKEY.....	264
BITTX25.....	264
BITTX25-RC3.....	264
BITTX25-RC10.....	264
BPHX516G2.....	253, 264, 266
BPHXLB14G2.....	253
BPHXLBGGP14G2.....	237, 264, 266
BPHXLBGGP516G2.....	237, 264, 266
BPHXLBPPG2.....	248, 256, 264, 266
BPHXLBSD2.....	264
BPHXLBSDG2.....	247, 256, 266
BPHXLBSDG2.....	264

C

C10ATN5.....	100
C10ATNB.....	100
C10TN5.....	101
C10TNB.....	101
C16ATN5.....	100
C16ATNB.....	100
C16HATN5.....	100
C16HATNB.....	100
C16HTN5.....	101
C16HTNB.....	101
C16TN5.....	101
C16TNB.....	101
C20ATN5.....	100
C20ATNB.....	100
C20TN5.....	101
C20TNB.....	101
C40ATN5.....	100
C40ATNB.....	100
C40TN5.....	101
C40TNB.....	101
C50ATN5.....	100
C50ATNB.....	100
C50TN5.....	101
C50TNB.....	101
C60ATN5.....	100
C60ATNB.....	100
C60TN5.....	101
C60TNB.....	101
C210ARN1.....	98
C210ARN5.....	98
C210ARNB.....	98
C210RN1.....	99
C210RN5.....	99
C210RNB.....	99
C211ARN1.....	98
C211ARN5.....	98
C211ARNB.....	98
C211RN1.....	99
C211RN5.....	99
C211RNB.....	99
C310ARN1.....	98
C310ARN5.....	98
C310ARNB.....	98
C310RN1.....	99
C310RN5.....	99
C310RNB.....	99
C311ARN1.....	98
C311ARN5.....	98
C311ARNB.....	98
C311RN1.....	99
C311RN5.....	99
C311RNB.....	99
C410ARN1.....	98
C410ARN5.....	98
C410ARNB.....	98

Alphabetical Index

C410RN1.....	99	DCLG212MB.....	76	DSVT158R1LB.....	63
C410RN5.....	99	DCLG212R350.....	76	DSVT158R5LB.....	63
C410RNB.....	99	DCLG212S.....	172, 186	DSVT158R350.....	63
C411ARN1.....	98	DCLR3MB.....	76	DSVT158S.....	172, 174
C411ARN5.....	98	DCLR3R350.....	76	DSVT212MB.....	63
C411ARNB.....	98	DCLR3S.....	172, 186	DSVT212R1LB.....	63
C411RN1.....	99	DCLR212MB.....	76	DSVT212R5LB.....	63
C411RN5.....	99	DCLR212R350.....	76	DSVT212R350.....	63
C411RNB.....	99	DCLR212S.....	172, 186	DSVT212S.....	172, 174
C510ARN1.....	98	DCLSS3MB.....	76	DSVT312MB.....	63
C510ARN5.....	98	DCLSS3R350.....	76	DSVT312R1LB.....	63
C510ARNB.....	98	DCLSS212MB.....	76	DSVT312R5LB.....	63
C510RN1.....	99	DCLSS212R350.....	76	DSVT312R350.....	63
C510RN5.....	99	DCLT3MB.....	76	DTHQ2S.....	172, 176
C510RNB.....	99	DCLT3R350.....	76	DTHQ3S.....	172, 176
C511ARN1.....	98	DCLT3S.....	172, 186	DTHQ212S.....	172, 176
C511ARN5.....	98	DCLT212MB.....	76	DW267QD.....	260
C511ARNB.....	98	DCLT212R350.....	76	DW276QD.....	260
C511RN1.....	99	DCLT212S.....	172, 186	DWC1PS.....	173, 190
C511RN5.....	99	DCSD238SBR01.....	173, 187	DWC2PS.....	173, 190
C511RNB.....	99	DCSD238SGR01.....	173, 187	DWC114PS.....	173, 190
C610ARN1.....	98	DCSD238SGR04.....	173, 187	DWC158PS.....	173, 190
C610ARN5.....	98	DCSD238SRD01.....	173, 187	DWC212PS.....	173, 190
C610ARNB.....	98	DCSD238STN01.....	173, 187	DWCG114PS.....	179
C610RN1.....	99	DCSD238STN02.....	173, 187	DWCG158PS.....	179
C610RN5.....	99	DDX3BR01MB.....	74	DWCZ2PS.....	173, 190
C610RNB.....	99	DDX3BR01R350.....	74	DWCZ114PS.....	173, 190
C611ARN1.....	98	DDX3GR01MB.....	74	DWCZ158PS.....	173, 190
C611ARN5.....	98	DDX3GR01R350.....	74	DWF1PS.....	173, 200
C611ARNB.....	98	DDX3GR04MB.....	74	DWF114PS.....	173, 200
C611RN1.....	99	DDX3GR04R350.....	74	DWF158PS.....	173, 200
C611RN5.....	99	DDX3RD01MB.....	74	DWFSD114PS.....	173, 200
C611RNB.....	99	DDX3RD01R350.....	74	DWFSD158PS.....	173, 200
C810ARN1.....	98	DDX3TN01MB.....	74	DWFSD178PS.....	173, 200
C810ARN5.....	98	DDX3TN01R350.....	74	DWFSD238PS.....	173, 200
C810ARNB.....	98	DDX3TN02MB.....	74	DWFSDG114PS.....	173, 200
C810RN1.....	99	DDX3TN02R350.....	74	DWHL178PS.....	173, 191
C810RN5.....	99	DDX212BR01MB.....	74		
C810RNB.....	99	DDX212BR01R350.....	74	E	
C811ARN1.....	98	DDX212GR01MB.....	74	E1B1414.....	271, 328
C811ARN5.....	98	DDX212GR01R350.....	74	E1B1414B.....	124
C811ARNB.....	98	DDX212GR04MB.....	74	E1B1414R100.....	124
C811RN1.....	99	DDX212GR04R350.....	74	EBE002.....	120
C811RN5.....	99	DDX212RD01MB.....	74	EBE004.....	120
C811RNB.....	99	DDX212RD01R350.....	74	EBE005LC.....	120
C1010ARN1.....	98	DDX212TN01MB.....	74	EBE006JR.....	120
C1010ARN5.....	98	DDX212TN01R350.....	74	EBE007MINI.....	120
C1010ARNB.....	98	DDX212TN02MB.....	74	EBEOA.....	120
C1010RN1.....	99	DDX212TN02R350.....	74	EPB44.....	323
C1010RN5.....	99	DHPDSS212MB.....	66	EPB44PHDG.....	323
C1010RNB.....	99	DHPDSS212R100.....	66	EPC44.....	323
C7511ARN1.....	98	DHPDSS212R350.....	66	EPC44-16.....	323
C7511ARN5.....	98	DHPDSS212R1000.....	66		
C7511ARNB.....	98	DJT14Z.....	323	F	
C7511RN1.....	99	DPT5Z.....	323	F06T125BDB.....	127
C7511RN5.....	99	DPT7Z.....	323	F06T125BDC.....	127
C7511RNB.....	99	DSVT2MB.....	63	F06T125BDM.....	127
CB3BLG114S.....	172, 177	DSVT2R1LB.....	63	F06T125TDB.....	130
CB3BLG158S.....	172, 177	DSVT2R5LB.....	63	F07T162TDB.....	130
CB3BLGH114S.....	172, 178	DSVT2R350.....	63	F07T162TDC.....	130
CB3BLGH158S.....	172, 178	DSVT2S.....	172, 174	F07T162TDM.....	130
CBSDQ158S.....	172, 199	DSVT3MB.....	63	F07T225TDB.....	130
CBSDQ214S.....	172, 199	DSVT3R1LB.....	63	F07T225TDC.....	130
CTS218.....	323	DSVT3R5LB.....	63	F07T225TDM.....	130
		DSVT3R350.....	63	F07T300TDB.....	130
D		DSVT3S.....	172, 174	F07T300TDC.....	130
DCLB3MB.....	76	DSVT4MB.....	63	F07T300TDM.....	130
DCLB3R350.....	76	DSVT4R1LB.....	63	F08T056KDB.....	132
DCLB3S.....	172, 186	DSVT4R5LB.....	63	F08T056KDC.....	132
DCLB212MB.....	76	DSVT4R350.....	63	F08T056KDM.....	132
DCLB212R350.....	76	DSVT114MB.....	63	F08T075KDB.....	132
DCLB212S.....	172, 186	DSVT114R1LB.....	63	F08T075KDC.....	132
DCLG3MB.....	76	DSVT114R5LB.....	63	F08T075KDM.....	132
DCLG3R350.....	76	DSVT114S.....	174	F08T125KDB.....	132
DCLG3S.....	172, 186	DSVT158MB.....	63	F08T125KDC.....	132

Alphabetical Index

F08T125KDM	132
F08T162BDB	127
F08T162BDC	127
F08T162BDM	127
F08T162KDB	132
F08T162KDC	132
F08T162KDM	132
F08T162WDB	128
F08T162WDC	128
F08T162WDM	128
F08T200BDB	127
F08T200BDC	127
F08T200BDM	127
F08T200KDB	132
F08T200KDC	132
F08T200KDM	132
F08T225WDB	128
F08T225WDC	128
F08T225WDM	128
F10C144WDB	131
F10C144WDC	131
F10C144WDM	131
F10T100PSB	126
F10T100PSC	126
F10T100PSM	126
F10T100PTB	113
F10T100PTC	113
F10T100PTM	113
F10T200PTC	113
F10T200PTM	113
F10T250BDB	127
F10T250BDC	127
F10T250BDM	127
F10T300BDB	127
F10T300BDC	127
F10T350BDB	127
F10T350BDC	127
F12C200FDB	129
F12C200FDC	129
F12C200FDM	129
F12C250FDB	129
F12C250FDC	129
F12C250FDM	129
F14C200T10	131
F14C300T10	131
F14C325FDB	129
F14C325FDC	129
F14C400T10	131
F14C500T10	131
F14C600T5	131
F14C700T5	131
F14C800T1	131
F14400TIPC	131
F14600TIPC	131
FB24	323
FB24R	323
FB26	323
FBR24Z	323
FHSD1S1018	173, 201
FHSD114S0818	173, 201
FHSD212S1214	173, 201
FPBM44	323
FPHSD34B1016	124
FPHSD34B1016-5K	124
FPHSD34B1214	124
FPHSD34B1214-5K	124
FPHSD34S1016	173, 195
FPHSD34S1214	173, 195
FWH2	323

G

G2HANDLE	265
GA1	323
GA2	323

H

H1	323
H2.5	323
H2.5A	294, 299, 323
H4	323
H5	323
H8	323
H10	323
HCKCB3BLG114S	177
HCKCB3BLG158S	177
HCKCB3BLGHL114S	178
HCKCB3BLGHL158S	178
HCKDCLB3S	186
HCKDCLB212S	186
HCKDCLG3S	186
HCKDCLG212S	186
HCKDCLR3S	186
HCKDCLR212S	186
HCKDCLT3S	186
HCKDCLT212S	186
HCKDSVT2S	174
HCKDSVT3S	174
HCKDSVT114S	174
HCKDSVT158S	174
HCKDSVT212S	174
HCKDTHQ2S	176
HCKDTHQ3S	176
HCKDTHQ212S	176
HCKDWC114PS	190
HCKDWC158PS	190
HCKMTH114S	191
HCKSSDCL3S	186
HCKSSDCL212S	186
HCKSSDHPD212S	175
HCKWSHL134S7	190
HCKWSNTG212S	175
HCKWSNTL2LS	188
HCKWSNTL3S	188
HCKWSNTL134S	188
HCKWSNTL212S	188
HCKWSNTLG2S	175
HCKWSNTLG3S	175
HG112WS	173, 180, 181
HG112WSBROWN	181
HG112WSBRRED	181
HG112WSBRWHITE	181
HG112WSDKGRAY	181
HG112WSDKGREEN	181
HG112WSGRAY	181
HG112WSMDGREEN	181
HG112WSRED	181
HG112WSSADDLE	181
HG112WSTAN	181
HG112WSX	181
HG112WT10	173, 180, 181
HIW8VB2	241, 253, 261
HJ112WT10	173, 180
HJ112WT10-0105	181
HJ112WT10-0402	181
HJ112WT10-0434	181
HJ112WT10-0701	181
HJ112WT10-0703	181
HJ112WT10-1005	181
HJ112WT10-1006	181
HJ112WT10-1103	181
HJ112WT10-1106	181
HJ112WT10-1107	181
HJ112WT10-X	181
HPTZ	323
HRS6	323
HRS8	323
HRS12	323
HTP37Z	323
HUS26	323
HUS28	323

I

I6PSN1	92
I6PSN5	92
I6PSNB	92
I8PSN1	92
I8PSN5	92
I8PSNB	92
I10PSN1	92
I10PSN5	92
I10PSNB	92
I16PSN1	92
I16PSN5	92
I16PSNB	92

L

L30	323
L50	323
L70	323
L70Z	312
L90	323
LCE4	323
LPC4Z	323
LS70Z	312
LSCZ	323
LSTA9	323
LSTA12	323
LSTA15	323
LSTA18	323
LSTA21	323
LSTA24	323
LSTA30	323
LSTA36	323
LSTI49	323
LSTI73	323
LTP4	323
LU24 (10d)	323
LU26 (10d)	323
LU28 (10d)	323
LU210 (10d)	323
LUC26Z (10d)	323
LUC26Z (16d)	323
LUC210Z (10d)	323
LUC210Z (16d)	323
LUS24	323
LUS24-2	323
LUS26	323
LUS26-2	323
LUS28	323
LUS28-2	323
LUS210	323
LUS210-2	323

M

MA6807Z	261
MAFS2500	260
MAFS2701	260
MAFS3500	260
MAFS6200	261
MST27	323
MST37	323
MST48	323
MST60	323
MST72	323
MSTA9	323
MSTA12	323
MSTA15	323
MSTA18	323
MSTA21	323
MSTA24	323
MSTA30	323
MSTA36	323
MSTA49	323
MSTC28	323
MSTC40	323

Alphabetical Index

MSTC52	323
MSTC66	323
MSTC78	323
MSTI26	323
MSTI36	323
MSTI48	323
MSTI60	323
MSTI72	323
MTH114S	172, 191
MTHZ1S	172, 191
MTS12	294, 299, 323
MTS16	323
MTS20	323
MW6742	261
MW6790	261

N

N8D5HDG	103
N8DHDG	103
N8HDGPT500	152
N10D5HDG	103
N10DHDG	103
N10DHDGPT500	152
N10HDGPT500	152
N16HDGPT500	152
N54A	102
N54AHDG	102
NS1	323
NS2	323

P

PADJARMBGP300G2	265
PBS44A	323
PC1B1012-5K	114
PC1B1211-4K	114
PC1BS1012	173, 271, 192
PC1BS1211	173, 271, 192
PC44	323
PC44-16	323
PCAPS100	118
PCQ1B1012-5K	114
PCQ1B1211-4K	114
PCQ1BS1012	173, 182
PCQ1BS1211	173, 182
PCQ112B1012-4K	114
PCQ112BS1012	173, 182
PCSD1B1016-5K	126
PCSD1B1214-4K	126
PCSD1S1016	173, 198
PCSD1S1214	173, 198
PCSDQ1B1016-5K	126
PCSDQ1B1214-4K	126
PCSDQ1S1016	173, 198
PCSDQ1S1214	173, 198
PCULP1B1012-5K	114
PCULP1BS1012	173, 271, 192
PCULP112B1012-4K	114
PCULP112BS1012	173, 192
PCULPQ1B1012-5K	114
PCULPQ1BS1012	173, 183
PCULPQ112BS1012	173, 183
PF24	323
PF24A	323
PF26	323
PF26A	323
PF26L	323
PF26L	323
PFDS24	323
PFDS26	323
PFEEDPAWL	265
PFEEDPAWL2	265
PFEEDPAWL3	265
PFEEDPAWL5	265

PFEEDPAWLTL	265
PHSD34S0818	173, 195
PHSS2S	172, 193
PHSS212S	172, 193
PMANDREL6	264
PMANDREL10	248, 256, 264, 266
PMANDREL55	264
PMANDREL65	238, 243, 244, 249, 254, 257, 259, 266
PMANDREL65-RC	264
PMANDREL75	239, 240, 241, 242, 245, 246, 249, 250, 251, 252, 255, 257, 258, 259, 266
PMANDREL75-RC	264
PMANDREL158	264
PMANDRELEXTG2-16	247, 264
PNOSECLIP	265
PNOSEGUARD-5	253, 254, 265
PPROFILEGUIDE5V	265
PPROFILEGUIDE11	265
PPROFILEGUIDE22	265
PPROFILEGUIDE23	265
PPROFILEGUIDE32	265
PPROFILEGUIDE33	265
PPROFILEGUIDE34	265
PPSD3B1016-2K	123
PPSD3B1214-2K	123
PPSD3S1016	173, 196
PPSD3S1214	173, 196
PPSD134B1016-4K	123
PPSD134B1214-4K	123
PPSD134S1016	173, 196
PPSD134S1214	173, 196
PPSD11516B-4K	123
PPSD11516S	271
PPSD11516S0818	173, 196
PPSDQ3B1016-2K	123
PPSDQ3B1214-2K	123
PPSDQ3S1016	196, 313
PPSDQ3S1214	196
PPSDQ134B1016-4K	123
PPSDQ134B1214-4K	123
PPSDQ134S1016	196, 313
PPSDQ134S1214	196
PPSDQ11516B-4K	123
PPSDQ11516S0818	196, 313
PRO200G2D25K	238, 260
PRO200G2M25K	238, 260
PRO250G2D25K	239, 260
PRO250G2M25K	239, 260
PRO250G2M35K	239, 260
PRO250G2MW40K	261
PRO250MW25K	239, 261
PRO250MMW40K	239
PRO300SD25K	240, 260
PRO300SM25K	240, 260
PRO300SM35K	240, 260
PRO300SMW25K	240, 261
PRO300SMW40K	240, 261
PRO300SRFG2M25K	246, 260
PRO300SRFG2M35K	246, 260
PROCCS+D25K	258, 260
PROCCS+M25K	258, 260
PROCGBM25K	259, 260
PROHSD60H17K	241, 261
PROHSD60M25K	241, 260
PROHSD60MVK	241, 261
PROHSD75H17K	242, 261
PROHSD75MVK	242, 261
PROLDHG2M25K	243, 244, 260
PROPP150G2DATK	247, 248
PROPP150G2M25K	248, 260
PROPP150G2MATK	248, 260
PRORFG2M25K	245, 260
PRORFG2M35K	245, 260
PROSD150G2DATK	260

PROSDDD25K	257, 260
PROSDDM25K	257, 260
PROSDDM35K	257, 260
PROSDDM45K	257
PROSDDMW25K	257, 261
PROSDDMW40K	257, 261
PSPFN58Z	323

Q

QDBGP300G2K	237, 266
QDDECKCLIP-RC	265
QDEXTG2	265
QDEXTG2-16	247, 265
QDEXTG2-22	265
QDEXTG2-T	265
QDHSD60	241, 252, 266
QDHSD75	242, 252, 266
QDLEAFSPRING	264
QDLEAFSPRING2	264
QDPRO200SG2	259
QDPRO200G2	238, 249, 257, 266
QDPRO200S	249
QDPRO200SG2	258, 259
QDPRO250DWG2	250
QDPRO250G2	239, 250, 266
QDPRO300SG2	240, 251, 257, 258, 266
QDPRO300SRFG2	246, 255, 266
QDPROHX14	253
QDPROHX516G2	253, 266
QDPROLDHG2	243, 244, 254, 259, 266
QDPROPHG2	254, 266
QDPROPP150G2	247, 248, 256, 266
QDPRORFG2	245, 255, 266
QDPROSD150G2	256, 266
QUIVER	265

R

RR	323
RSP4	323

S

S2ACN1	85
S2ACN5	85
S2ACNB	85
S2CN1	86
S2CN5	86
S2CNB	86
S2FN1	88
S2FN5	88
S2FNB	88
S2HACN1	85
S2HACN5	85
S2HACNB	85
S3ABN1	82
S3ABN5	82
S3ABNB	82
S3ACDRWVR1	84
S3ACDRWVR5	84
S3ACN1	85
S3ACN5	85
S3ACNB	85
S3CN1	86
S3CN5	86
S3CNB	86
S3FN1	88
S3FN5	88
S3FNB	88
S3SN7B	95
S3SN71	95
S3SN75	95
S3SND1	84
S3SND5	84
S3SND8	84
S4ABN1	82

Alphabetical Index

S4ABN5.....	82	S6SN75.....	95	S08C225PAK.....	69
S4ABNB.....	82	S6SND1.....	84	S08C250PAK.....	69
S4ACN1.....	85	S6SND5.....	84	S08C250TSC.....	116
S4ACN5.....	85	S6SNDB.....	84	S08C250TSM.....	116
S4ACNB.....	85	S6SNDB1.....	94	S08C300PAK.....	69
S4CN1.....	86	S6SNDB5.....	94	S8CN1.....	86
S4CN5.....	86	S6SNDBB.....	94	S8CN5.....	86
S4CNB.....	86	S6SNDG1.....	94	S8CNB.....	86
S4FN1.....	88	S6SNDG5.....	94	S8CRD1.....	83
S4FN5.....	88	S6SNDGB.....	94	S8CRD5.....	83
S4FNB.....	88	S6SNDR1.....	94	S8CRDB.....	83
S4HCN1.....	86	S6SNDR5.....	94	S8CRDG1.....	83
S4HCN5.....	86	S6SNDRB.....	94	S8CRDG5.....	83
S4HCNB.....	86	S6SNDS1.....	94	S8CRDGB.....	83
S4PTD1.....	91	S6SNDS5.....	94	S8CRDR1.....	83
S4PTD5.....	91	S6SNDSB.....	94	S8CRDR5.....	83
S4PTDB.....	91	S6SNDT1.....	94	S8CRDRB.....	83
S4SN7B.....	95	S6SNDT5.....	94	S8CRDT1.....	83
S4SN71.....	95	S6SNDTB.....	94	S8CRDT5.....	83
S4SN75.....	95	S6SNDW1.....	94	S8CRDTB.....	83
S4SND1.....	84	S6SNDW5.....	94	S8FN1.....	88
S4SND5.....	84	S6SNDWB.....	94	S8FN5.....	88
S4SNDB.....	84	S7ABN1.....	82	S8FNB.....	88
S4SNDR1.....	94	S7ABN5.....	82	S8HPTD1.....	91
S4SNDR5.....	94	S7ABNB.....	82	S8HPTD5.....	91
S4SNDRB.....	94	S7ACN1.....	85	S8HPTDB.....	91
S4SNDT1.....	94	S7ACN5.....	85	S8N350CNJ.....	148
S4SNDT5.....	94	S7ACNB.....	85	S8PTD1.....	91
S4SNDWB.....	94	S07C100PAK.....	71	S8PTD5.....	91
S5ABN1.....	82	S07C125PAK.....	71	S8PTDB.....	91
S5ABN5.....	82	S07C162FBP.....	71	S8SN7B.....	95
S5ABNB.....	82	S07C162PAK.....	71	S8SN71.....	95
S5ACN1.....	85	S07C162XOC.....	115	S8SN75.....	95
S5ACN5.....	85	S07C162XOM.....	115	S8SND1.....	84
S5ACNB.....	85	S07C200PAK.....	71	S8SND5.....	84
S5CN1.....	86	S07C225FBP.....	71	S8SNDB.....	84
S5CN5.....	86	S07C225PAK.....	71	S8SNDB1.....	94
S5CNB.....	86	S07C225XOC.....	115	S8SNDB5.....	94
S5FN1.....	88	S07C225XOM.....	115	S8SNDBB.....	94
S5FN5.....	88	S07C250PAK.....	71	S8SNDG1.....	94
S5FNB.....	88	S07C300FBP.....	71	S8SNDG5.....	94
S5FNX1.....	87	S07C300PAK.....	71	S8SNDGB.....	94
S5FNX5.....	87	S07C300XOC.....	115	S8SNDR1.....	94
S5FNXB.....	87	S7CN1.....	86	S8SNDR5.....	94
S5SN7B.....	95	S7CN5.....	86	S8SNDRB.....	94
S5SN71.....	95	S7CNB.....	86	S8SNDS1.....	94
S5SN75.....	95	S7SN7B.....	95	S8SNDS5.....	94
S5SND1.....	84	S7SN71.....	95	S8SNDSB.....	94
S5SND5.....	84	S7SN75.....	95	S8SNDT1.....	94
S5SNDB.....	84	S7SND1.....	84	S8SNDT5.....	94
S6ABN1.....	82	S7SND5.....	84	S8SNDTB.....	94
S6ABN5.....	82	S7SNDB.....	84	S8SNDW1.....	94
S6ABNB.....	82	S8ABN1.....	82	S8SNDW5.....	94
S6ACN1.....	85	S8ABN5.....	82	S8SNDWB.....	94
S6ACN5.....	85	S8ABNB.....	82	S9A225CNJ.....	146
S6ACNB.....	85	S8ACN1.....	85	S09C350FBP.....	71
S6APB1.....	90	S8ACN5.....	85	S09C350PAK.....	71
S6APB5.....	90	S8ACNB.....	85	S9N237CNJ.....	148
S6APBB.....	90	S8APB1.....	90	S9N300CNJ.....	148
S06C125DBP.....	69	S8APB5.....	90	S10A150XOC.....	89
S06C162DBP.....	69	S8APBB.....	90	S10A150XOM.....	89
S6CN1.....	86	S08C075KQC.....	115	S10A175XOC.....	89
S6CN5.....	86	S08C075KQM.....	115	S10A175XOM.....	89
S6CNB.....	86	S08C100TSC.....	116	S10A200XOC.....	89
S6FN1.....	88	S08C100TSM.....	116	S10A200XOM.....	89
S6FN5.....	88	S08C125KQC.....	115	S10A250CNB.....	146
S6FNB.....	88	S08C125KQM.....	115	S10A300CNB.....	146
S6FNX1.....	87	S08C125PAK.....	69	S10A300CNJ.....	146
S6FNX5.....	87	S08C125TSC.....	116	S10A300PNJ.....	143
S6FNXB.....	87	S08C125TSM.....	116	S10A325B31.....	149
S6PTD1.....	91	S08C150TSC.....	116	S10A325CNB.....	146
S6PTD5.....	91	S08C150TSM.....	116	S10A325CNJ.....	146
S6PTDB.....	91	S08C162PAK.....	69	S10A325KDJ.....	145
S6SN7B.....	95	S08C200DBP.....	69	S10A325KJB.....	145
S6SN71.....	95	S08C200PAK.....	69	S10A325KJG.....	145

Alphabetical Index

S10A325KJR.....	145	S10SNDT1.....	94	S12A175DNB.....	136
S10A325KJS.....	145	S10SNDT5.....	94	S12A175PNB.....	143
S10A325KJT.....	145	S10SNDTB.....	94	S12A200CNB.....	146
S10A325P31.....	149	S10SNDW1.....	94	S12A200CNJ.....	146
S10A325PNJ.....	143	S10SNDW5.....	94	S12A200PNB.....	143
S10A325T31.....	151	S10SNDWB.....	94	S12A200T31.....	151
S10A325W28.....	150	S10T100PDC.....	113	S12A225DNB.....	136
S10A350CNB.....	146	S10T100PDM.....	113	S12A225DNBP.....	136
S10A350CNJ.....	146	S10T100PDQ25.....	113	S12A237B31.....	149
S10A350T31.....	151	S10T125P25.....	113	S12A237CNB.....	146
S10ABN1.....	82	S10T125PDC.....	113	S12A237CNJ.....	146
S10ABN5.....	82	S10T125PDM.....	113	S12A237P31.....	149
S10ABNB.....	82	S10T150P25.....	113	S12A237PNB.....	143
S10ACN1.....	85	S10T150PDC.....	113	S12A237T31.....	151
S10ACN5.....	85	S10T150PDM.....	113	S12A237W28.....	150
S10ACNB.....	85	S10T200P25.....	113	S12A250PNB.....	143
S10APB1.....	90	S10T200PDC.....	113	S12A300PNJ.....	143
S10APB5.....	90	S10T200PDM.....	113	S12ABN1.....	82
S10APBB.....	90	S10TN5.....	101	S12ABN5.....	82
S10ATN5.....	100	S10TNB.....	101	S12ABNB.....	82
S10ATNB.....	100	S11A100RNB.....	141	S12ACN1.....	85
S10C250DBP.....	69	S11A125RNB.....	141	S12ACN5.....	85
S10C250DTP.....	67	S11A125RNBP.....	141, 143	S12ACNB.....	85
S10C250PAK.....	69	S11A125RNJ.....	141	S12APB1.....	90
S10C300DBP.....	69	S11A150RNB.....	141	S12APB5.....	90
S10C300DPI.....	68	S11A150RNBP.....	141, 143	S12APBB.....	90
S10C300DPT.....	68	S11A150RNJ.....	141	S12CN1.....	86
S10C300DTP.....	67	S11A175RNB.....	141	S12CN5.....	86
S10C300PAK.....	69	S11A175RNBP.....	141, 143	S12CNB.....	86
S10C350DBP.....	69	S11A175RNJ.....	141	S12CRD1.....	83
S10C350PAK.....	69	S11A175X0C.....	89	S12CRD5.....	83
S10CN1.....	86	S11A175X0M.....	89	S12CRDB.....	83
S10CN5.....	86	S11A200CNB.....	146	S12CRDG1.....	83
S10CNB.....	86	S11A200CNJ.....	146	S12CRDG5.....	83
S10CRD1.....	83	S11A237KDJ.....	145	S12CRDGB.....	83
S10CRD5.....	83	S11A237KJB.....	145	S12CRDR1.....	83
S10CRDB.....	83	S11A237KJG.....	145	S12CRDR5.....	83
S10CRDG1.....	83	S11A237KJR.....	145	S12CRDRB.....	83
S10CRDG5.....	83	S11A237KJS.....	145	S12CRDT1.....	83
S10CRDGB.....	83	S11A237KJT.....	145	S12CRDT5.....	83
S10CRDR1.....	83	S11A250CNB.....	146	S12CRDTB.....	83
S10CRDR5.....	83	S11A250CNJ.....	146	S12FN1.....	88
S10CRDRB.....	83	S11A300B31.....	149	S12FN5.....	88
S10CRDT1.....	83	S11A300CNB.....	146	S12FNB.....	88
S10CRDT5.....	83	S11A300CNJ.....	146	S12N062SWC.....	119
S10CRDTB.....	83	S11A300P31.....	149	S12N062SWM.....	119
S10FN1.....	88	S11A300PJB.....	144	S12N237CNB.....	148
S10FN5.....	88	S11A300PJG.....	144	S12N237CNJ.....	148
S10FNB.....	88	S11A300PJR.....	144	S12PTD1.....	91
S10HPTD1.....	91	S11A300PJT.....	144	S12PTD5.....	91
S10HPTD5.....	91	S11A300PNJ.....	143	S12PTDB.....	91
S10HPTDB.....	91	S11A300T31.....	151	S12S200CNB.....	147
S10N062SWC.....	119	S11A300W28.....	150	S12S200CNJ.....	147
S10N062SWM.....	119	S11A325CNB.....	146	S12S250CNB.....	147
S10N112SWC.....	119	S11A325CNJ.....	146	S12S250CNJ.....	147
S10N112SWM.....	119	S11A325PJB.....	144	S12SND1.....	84
S10PTD1.....	91	S11A325PJG.....	144	S12SND5.....	84
S10PTD5.....	91	S11A325PJR.....	144	S12SNDB.....	84
S10PTDB.....	91	S11A325PJT.....	144	S13A125SNBP.....	139
S10S150X0C.....	89	S11A325PNJ.....	143	S13A125SNC.....	139
S10S150X0M.....	89	S11N075RNB.....	142	S13A150IPC.....	137
S10S350CNB.....	147	S11N087RNB.....	142	S13A150SNBP.....	139
S10S350CNJ.....	147	S11N100RNB.....	142	S13A150SNC.....	139
S10SND1.....	84	S11N100RNJ.....	142	S13A175IPC.....	137
S10SND5.....	84	S11N125RNB.....	142	S13A175SNBP.....	139
S10SNDB.....	84	S11N125RNJ.....	142	S13A175SNC.....	139
S10SNDB1.....	94	S11N150RNB.....	142	S13A200CCB.....	140
S10SNDB5.....	94	S11N150RNJ.....	142	S13A200CCG.....	140
S10SNDBB.....	94	S11N175RNB.....	142	S13A200CCR.....	140
S10SNDG1.....	94	S11N175RNJ.....	142	S13A200CCT.....	140
S10SNDG5.....	94	S11S300CNB.....	147	S13A200CWH.....	140
S10SNDGB.....	94	S11S300CNJ.....	147	S13A200IPC.....	137
S10SNDR1.....	94	S11S325CNB.....	147	S13A200SNBP.....	139
S10SNDR5.....	94	S11S325CNJ.....	147	S13A200SNC.....	139
S10SNDRB.....	94	S12A150PNB.....	143	S13A200WCCBP.....	140

Alphabetical Index

S13A225CCB	140	S16N100N13	163	S20ACN5	85
S13A225CCG	140	S16N125GS	161	S20ACNB	85
S13A225CCFR	140	S16N125GS-R1000	161	S20APB1	90
S13A225CCS	140	S16N125N15	163	S20APB5	90
S13A225CCT	140	S16N125N15-R1000	163	S20APBB	90
S13A225CWH	140	S16N125P55	160	S20ATN5	100
S13A225IPBP	137	S16N125PFB	153	S20ATNB	100
S13A225IPC	137	S16N125PFN	153	S20CN1	86
S13A225SNBP	139	S16N150FNB	155	S20CN5	86
S13A225SNC	139	S16N150FNJ	155	S20CNB	86
S13A250CCB	140	S16N150GS	161	S20FN1	88
S13A250CCG	140	S16N150GS-R1000	161	S20FN5	88
S13A250CCFR	140	S16N150N17	163	S20FNB	88
S13A250CCS	140	S16N150N17-R1000	163	S20HPTD1	91
S13A250CCT	140	S16N150PFB	153	S20HPTD5	91
S13A250CWH	140	S16N150PFN	153	S20HPTDB	91
S13A250IPBP	137	S16N175GS	161	S20PTD1	91
S13A250IPC	137	S16N175GS-R1000	161	S20PTD5	91
S13A250IPWBP	138	S16N175N19	163	S20PTDB	91
S13A250SNBP	139	S16N200FNB	155	S20SND1	84
S13A250SNC	139	S16N200FNJ	155	S20SND5	84
S13A250VWCBP	140	S16N200GS	161	S20SND8	84
S15N150FNB	154	S16N200N21	163	S20TN5	101
S15N150FNJ	154	S16N200N21-R1000	163	S20TNB	101
S15N150SFB	158	S16N200PFB	153	S22N025C04	164
S15N150SFN	158	S16N200PFN	153	S22N037C06	164
S15N200BFS	160	S16N250FNB	155	S22N050C08	164
S15N200FNB	154	S16N250FNJ	155	S23N050MPB	157
S15N200FNJ	154	S16N250PFB	153	S23N050MPN	157
S15N200SFB	158	S16N250PFN	153	S23N075MPB	157
S15N200SFN	158	S16PTD1	91	S23N075MPN	157
S15N250FNB	154	S16PTD5	91	S23N100MPB	157
S15N250FNJ	154	S16PTDB	91	S23N100MPN	157
S15N250SFB	158	S16SND1	84	S23N119MPB	157
S15N250SFN	158	S16SND5	84	S23N119MPN	157
S16ABN1	82	S16SND8	84	S23N150MPB	157
S16ABN5	82	S16SND8B	94	S23N150MPN	157
S16ABNB	82	S16SND8B5	94	S23N175MPB	157
S16ACN1	85	S16SND8BB	94	S23N175MPN	157
S16ACN5	85	S16SNDG1	94	S30ACN1	85
S16ACNB	85	S16SNDG5	94	S30ACN5	85
S16APB1	90	S16SNDGB	94	S30ACNB	85
S16APB5	90	S16SNDR1	94	S30APB1	90
S16APBB	90	S16SNDR5	94	S30APB5	90
S16ATN5	100	S16SNDRB	94	S30APBB	90
S16ATNB	100	S16SND51	94	S30CN1	86
S16B150LCT	159	S16SND55	94	S30CN5	86
S16B200LCT	159	S16SND5B	94	S30CNB	86
S16B200TNL	159	S16SNDT1	94	S40ACN1	85
S16CN1	86	S16SNDT5	94	S40ACN5	85
S16CN5	86	S16SNDTB	94	S40ACNB	85
S16CNB	86	S16TN5	101	S40APB1	90
S16CRD1	83	S16TNB	101	S40APB5	90
S16CRD5	83	S18N062L10	162	S40APBB	90
S16CRDB	83	S18N075FNB	156	S40ATN5	100
S16CRDG1	83	S18N075FNJ	156	S40ATNB	100
S16CRDG5	83	S18N100FNB	156	S40CN1	86
S16CRDGB	83	S18N100L13	162	S40CN5	86
S16CRDR1	83	S18N100L13-R1000	162	S40CNB	86
S16CRDR5	83	S18N112L14	162	S40TN5	101
S16CRDRB	83	S18N125FNB	156	S40TNB	101
S16CRDT1	83	S18N125FNJ	156	S50ATN5	100
S16CRDT5	83	S18N125L15	162	S50ATNB	100
S16CRDTB	83	S18N125L15-R1000	162	S50TN5	101
S16FN1	88	S18N150FNB	156	S50TNB	101
S16FN5	88	S18N150FNJ	156	S60ACN1	85
S16FNB	88	S18N150L17	162	S60ACN5	85
S16HATN5	100	S18N150L17-R1000	162	S60ACNB	85
S16HATNB	100	S18N175FNJ	156	S60APB1	90
S16HPTD1	91	S18N200FNB	156	S60APB5	90
S16HPTD5	91	S18N200FNJ	156	S60APBB	90
S16HPTDB	91	S20ABN1	82	S60ATN5	100
S16HTN5	101	S20ABN5	82	S60ATNB	100
S16HTNB	101	S20ABNB	82	S60CN1	86
S16N075P51	160	S20ACN1	85	S60CN5	86

Alphabetical Index

S60CNB.....	86	S07162FT5.....	73	S07250FB1.....	71
S60TN5.....	101	S07162FTB.....	73	S07250FB5.....	71
S60TNB.....	101	S07162FTP.....	73	S07250FBB.....	71
S70ACN1.....	85	S07162FTW1.....	72	S07250FBH.....	71
S70ACN5.....	85	S07162FW1.....	70	S07300FB1.....	71
S70ACNB.....	85	S07162TCW.....	72	S07300FB5.....	71
S70APB1.....	90	S07162TJW.....	72	S07300FBB.....	71
S70APB5.....	90	S07162WP1.....	65	S07300FT1.....	73
S70APBB.....	90	S07162WP5.....	65	S07300FT5.....	73
S70CN1.....	86	S07162WPB.....	65	S07300FTB.....	73
S70CN5.....	86	S07162WPP.....	65	S07300FTP.....	73
S70CNB.....	86	S07200FB1.....	71	S07300WP1.....	65
S210ARN1.....	97	S07200FB5.....	71	S07300WP5.....	65
S210ARN5.....	97	S07200FBB.....	71	S07300WPB.....	65
S210ARNB.....	97	S07200FBH.....	71	S7510ARN1.....	97
S310ARN1.....	97	S07225BTW1.....	72	S7510ARN5.....	97
S310ARN5.....	97	S07225BTW5.....	72	S7510ARNB.....	97
S310ARNB.....	97	S07225FB1.....	71	S08075DB1.....	69
S311ARN1.....	97	S07225FB5.....	71	S08075DB5.....	69
S311ARN5.....	97	S07225FBB.....	71	S08075DBB.....	69
S311ARNB.....	97	S07225FBK.....	70	S08100TSBC.....	116
S410ARN1.....	97	S07225FCA.....	70	S08112DB1.....	69
S410ARN5.....	97	S07225FCBR03.....	70	S08112DB5.....	69
S410ARNB.....	97	S07225FCBR04.....	70	S08112DBB.....	69
S411ARN1.....	97	S07225FCG.....	70	S08125DB1.....	69
S411ARN5.....	97	S07225FCI.....	70	S08125DB5.....	69
S411ARNB.....	97	S07225FCM.....	70	S08125DBB.....	69
S510ARN1.....	97	S07225FCRD02.....	70	S08125TSBC.....	116
S510ARN5.....	97	S07225FCTN04.....	70	S08150TSBC.....	116
S510ARNB.....	97	S07225FCW.....	70	S08162DB1.....	69
S511ARN1.....	97	S07225FCZ.....	70	S08162DB5.....	69
S511ARN5.....	97	S07225FJA.....	70	S08162DBB.....	69
S511ARNB.....	97	S07225FJBR03.....	70	S08162DT1.....	67
S610ARN1.....	97	S07225FJBR04.....	70	S08162DT5.....	67
S610ARN5.....	97	S07225FJG.....	70	S08162DTB.....	67
S610ARNB.....	97	S07225FJI.....	70	S08162WP1.....	64
S611ARN1.....	97	S07225FJK.....	70	S08162WP5.....	64
S611ARN5.....	97	S07225FJM.....	70	S08162WPB.....	64
S611ARNB.....	97	S07225FJRD02.....	70	S08162WPP.....	64
S810ARN1.....	97	S07225FJTN04.....	70	S08200DB1.....	69
S810ARN5.....	97	S07225FJW.....	70	S08200DB5.....	69
S810ARNB.....	97	S07225FKB.....	70	S08200DBB.....	69
S1010ARN1.....	97	S07225FKJ.....	70	S08200DT1.....	67
S1010ARN5.....	97	S07225FT1.....	73	S08200DT5.....	67
S1010ARNB.....	97	S07225FT5.....	73	S08200DTB.....	67
S06062DB1.....	69	S07225FTB.....	73	S08200WP1.....	64
S06062DB5.....	69	S07225FTP.....	73	S08200WP5.....	64
S06062DBB.....	69	S07225FW1.....	70	S08200WPB.....	64
S06075DB1.....	69	S07225FW5.....	70	S08200WPP.....	64
S06075DB5.....	69	S07225FZJ.....	70	S08225DB1.....	69
S06075DBB.....	69	S07225TCA.....	72	S08225DB5.....	69
S06100DB1.....	69	S07225TCB.....	72	S08225DBB.....	69
S06100DB5.....	69	S07225TCE.....	72	S08250DB1.....	69
S06100DBB.....	69	S07225TCG.....	72	S08250DB5.....	69
S06125DB1.....	69	S07225TCM.....	72	S08250DBB.....	69
S06125DB5.....	69	S07225TCS.....	72	S08250FWP.....	65
S06125DBB.....	69	S07225TCZ.....	72	S08250TCG.....	72
S06125DT1.....	67	S07225TJA.....	72	S08250TCJ.....	72
S06125DT5.....	67	S07225TJB.....	72	S08250TCT.....	72
S06125DTB.....	67	S07225TJE.....	72	S08250TJG.....	72
S06162DB1.....	69	S07225TJG.....	72	S08250TJJ.....	72
S06162DB5.....	69	S07225TJM.....	72	S08250TJT.....	72
S06162DBB.....	69	S07225TJS.....	72	S08250TSBC.....	116
S07100FB1.....	71	S07225TJZ.....	72	S08250WCI.....	65
S07100FB5.....	71	S07225TKC.....	72	S08250WJI.....	65
S07100FBB.....	71	S07225TKJ.....	72	S08250WPB.....	65
S07100FBH.....	71	S07225TPA.....	72	S08250WPF1.....	64
S07125FB1.....	71	S07225TPE.....	72	S08250WPF5.....	64
S07125FB5.....	71	S07225TPM.....	72	S08250WPFB.....	64
S07125FBB.....	71	S07225TPS.....	72	S08250WPP.....	65
S07125FBH.....	71	S07225TPZ.....	72	S08300DB1.....	69
S07162FB1.....	71	S07225WP1.....	65	S08300DB5.....	69
S07162FB5.....	71	S07225WP5.....	65	S08300DBB.....	69
S07162FBB.....	71	S07225WPB.....	65	S08300FWP.....	65
S07162FT1.....	73	S07225WPP.....	65	S08300WPB.....	65

Alphabetical Index

S08300WPF1	64	S10250DT5	67	S10300XPGR04	75
S08300WPF5	64	S10250DTB	67	S10300XPI	75
S08300WPFB	64	S10250DXB	75	S10300XPR	75
S08300WPP	65	S10250DXC	75	S10300XPRD01	75
S09350FB1	71	S10250DXP	75	S10300XPT	75
S09350FB5	71	S10250RNW5	96	S10300XPTN01	75
S09350FBB	71	S10250RNWB	96	S10300XPTN02	75
S09400FB1	71	S10250WP1	64	S10350DB1	69
S09400FB5	71	S10250WP5	64	S10350DB5	69
S09400FBB	71	S10250WPB	64	S10350DBB	69
S10100DB1	69	S10250WPP	64	S10350DT1	67
S10100DB5	69	S10250XBBR01	75	S10350DT5	67
S10100DBB	69	S10250XBG	75	S10350DTB	67
S10100WP1	64	S10250XBGR01	75	S10350WP1	64
S10100WP5	64	S10250XBGR04	75	S10350WP5	64
S10100WPB	64	S10250XBI	75	S10350WPB	64
S10125DB1	69	S10250XBR	75	S10375DB1	69
S10125DB5	69	S10250XB RD01	75	S10375DB5	69
S10125DBB	69	S10250XBT	75	S10375DBB	69
S10125PHB	117	S10250XBTN01	75	S12125HDUC	111
S10150DB1	69	S10250XBTN02	75	S12125HDUM	111
S10150DB5	69	S10250XC BR01	75	S12125HOC	112
S10150DBB	69	S10250XCG	75	S12125HOM	112
S10150DXB	75	S10250XCI	75	S12125HR1	105
S10150DXC	75	S10250XCR	75	S12131HR5	105
S10150DXP	75	S10250XCT	75	S12131HRB	105
S10150RNW5	96	S10250XPBR01	75	S12150HDUC	111
S10150RNWB	96	S10250XPG	75	S12150HDUM	111
S10150WP1	64	S10250XPGR01	75	S12150HOC	112
S10150WP5	64	S10250XPGR04	75	S12150HOM	112
S10150WPB	64	S10250XPI	75	S12200HDUC	111
S10150XBB	75	S10250XPR	75	S12200HDUM	111
S10150XBG	75	S10250XPRD01	75	S12200HOC	112
S10150XBI	75	S10250XPT	75	S12200HOM	112
S10150XBR	75	S10250XPTN01	75	S12250DB1	69
S10150XBT	75	S10250XPTN02	75	S12250DB5	69
S10150XCB	75	S10262PHB	117	S12250DBB	69
S10150XCG	75	S10300DB1	69	S12250HDUC	111
S10150XCI	75	S10300DB5	69	S12250HDUM	111
S10150XCR	75	S10300DBB	69	S12250WP1	64
S10150XCT	75	S10300DCG	68	S12250WP5	64
S10150XPB	75	S10300DCI	68	S12250WPB	64
S10150XPG	75	S10300DCT	68	S12300DB1	69
S10150XPI	75	S10300DJG	68	S12300DB5	69
S10150XPR	75	S10300DJI	68	S12300DBB	69
S10150XPT	75	S10300DJT	68	S12300HDUC	111
S10175DB1	69	S10300DT1	67	S12300HDUM	111
S10175DB5	69	S10300DT5	67	S12350DB1	69
S10175DBB	69	S10300DTB	67	S12350DB5	69
S10175RNW5	96	S10300DXB	75	S12350DBB	69
S10175RNWB	96	S10300DXC	75	S12350WP1	64
S10200DB1	69	S10300DXP	75	S12350WP5	64
S10200DB5	69	S10300RNW5	96	S12350WPB	64
S10200DBB	69	S10300RNWB	96	S12400DB1	69
S10200DXB	75	S10300WP1	64	S12400DB5	69
S10200DXP	75	S10300WP5	64	S12400DBB	69
S10200FS1	105	S10300WPB	64	S12400WP1	64
S10200FS5	105	S10300WPP	64	S12400WP5	64
S10200FSB	105	S10300XBBR01	75	S12400WPB	64
S10200RNW5	96	S10300XBG	75	S12400WPP	64
S10200RNWB	96	S10300XBGR01	75	S12450DB1	69
S10200WP1	64	S10300XBGR04	75	S12450DB5	69
S10200WP5	64	S10300XBI	75	S12450DBB	69
S10200WPB	64	S10300XBR	75	S12450WP1	64
S10225DB1	69	S10300XB RD01	75	S12450WP5	64
S10225DB5	69	S10300XBT	75	S12450WPB	64
S10225DBB	69	S10300XBTN01	75	S12500DB1	69
S10250DB1	69	S10300XBTN02	75	S12500DB5	69
S10250DB5	69	S10300XCG	75	S12500DBB	69
S10250DBB	69	S10300XCI	75	S12500WP1	64
S10250DCI	68	S10300XCR	75	S12500WP5	64
S10250DCT	68	S10300XCT	75	S12500WPB	64
S10250DJI	68	S10300XPBR01	75	S12550DB1	69
S10250DJT	68	S10300XPG	75	S12550DB5	69
S10250DT1	67	S10300XPGR01	75	S12550DBB	69

Alphabetical Index

S12600DB1.....	69	SDS25212.....	61, 318	SDWH19400DB-R50.....	59
S12600DB5.....	69	SDS25212MB.....	61	SDWH19400DB-RC12.....	59
S12600DBB.....	69	SDS25212-R25.....	61	SDWH19400SS.....	292
S13075HR1.....	105	SDS25212SS.....	61	SDWH19400SS-R20.....	60
S13075HR5.....	105	SDS25212SS-R25.....	61	SDWH19400SS-R100.....	60
S13075HRB.....	105	SDS25300.....	61, 318, 319	SDWH19450SS-R10.....	60
S13100FS1.....	105	SDS25300MB.....	61	SDWH19450SS-R100.....	60
S13100FS5.....	105	SDS25300-R25.....	61	SDWH19500SS.....	292
S13100FSB.....	105	SDS25300SS.....	61	SDWH19500SS-R10.....	60
S13125FS1.....	105	SDS25300SS-R25.....	61	SDWH19500SS-R100.....	60
S13125FS5.....	105	SDS25312.....	61, 318, 319, 320	SDWH19600DB.....	59, 283, 287, 288, 289, 290
S13125FSB.....	105	SDS25312MB.....	61	SDWH19600DBMB.....	59
S14050EP1.....	104	SDS25312-R10.....	61	SDWH19600DB-R50.....	59
S14050EP5.....	104	SDS25312-R25L.....	61	SDWH19600DB-RC12.....	59
S14075EP1.....	104	SDS25312SS.....	61, 320	SDWH19600SS-R10.....	60
S14075EP5.....	104	SDS25312SS-R25.....	61	SDWH19600SS-R100.....	60
S14075HR1.....	105	SDS25312SS-R25L.....	61	SDWH19800DB.....	59, 283, 287, 288
S14075HR5.....	105	SDS25412.....	61, 318, 319, 321	SDWH19800DBMB.....	59
S14075HRB.....	105	SDS25412MB.....	61	SDWH19800DB-R50.....	59
S14100EP1.....	104	SDS25412-R10.....	61	SDWH19800DB-RC12.....	59
S14100EP5.....	104	SDS25500.....	61, 318, 320, 321	SDWH19800SS-R10.....	60
S14150EP5.....	104	SDS25500MB.....	61	SDWH19800SS-R50.....	60
S14300DB1.....	69	SDS25500-R10.....	61	SDWH27300SS-R10.....	60
S14300DB5.....	69	SDS25500-R25L.....	61	SDWH27300SS-R100.....	60
S14300DBB.....	69	SDS25600.....	61, 318, 321	SDWH27400SS.....	293
S14350DB1.....	69	SDS25600MB.....	61	SDWH27400SS-R10.....	60
S14350DB5.....	69	SDS25600-R10.....	61	SDWH27400SS-R100.....	60
S14350DBB.....	69	SDS25800.....	61, 318	SDWH27500SS.....	293
S14400DB1.....	69	SDS25800-R10.....	61	SDWH27500SS-R10.....	60
S14400DB5.....	69	SDS25800-R50.....	61	SDWH27500SS-R50.....	60
S14400DBB.....	69	SDW22300.....	79, 301	SDWH27600SS-R10.....	60
S14400WP5.....	64	SDW22300MB.....	79	SDWH27600SS-R50.....	60
S14400WPB.....	64	SDW22300-R50.....	79	SDWH27800SS-R10.....	60
S14400WPP.....	64	SDW22338.....	78, 302	SDWH27800SS-R25.....	60
S14500DB1.....	69	SDW22338MB.....	78	SDWH19100DB.....	59, 283, 287, 288
S14500DB5.....	69	SDW22338-R50.....	78	SDWH19100DB-R50.....	59
S14500DBB.....	69	SDW22438.....	79, 301	SDWH19100DBRC12.....	59
S16050EP1.....	104	SDW22438MB.....	79	SDWH271000SS-R5.....	60
S16050EP5.....	104	SDW22438-R50.....	79	SDWH271000SS-R25.....	60
S16062EP1.....	104	SDW22458.....	79, 301	SDWH271200SS-R5.....	60
S16062EP5.....	104	SDW22458MB.....	79	SDWH271200SS-R25.....	60
S16075EP1.....	104	SDW22458-R50.....	79	SDWS22.....	280, 281
S16075EP5.....	104	SDW22500.....	78, 302	SDWS22DB.....	280, 281
S16100EP5.....	104	SDW22500MB.....	78	SDWS19600.....	282, 79
S18037EP1.....	104	SDW22500-R50.....	78	SDWS19712.....	282, 79
S18050EP1.....	104	SDW22600.....	79, 301	SDWS22300DB.....	58, 272
S18075EP5.....	104	SDW22600MB.....	79	SDWS22300DBMB.....	58
SD8x1.25.....	80, 326	SDW22600-R50.....	79	SDWS22300DB-R50.....	58
SD9112.....	322	SDW22634.....	78, 302	SDWS22300DB-RC12.....	58
SD9112MB.....	62	SDW22634MB.....	78	SDWS22400DB.....	58, 272, 273, 274, 275, 276, 277, 278, 281
SD9112R100.....	62	SDW22634-R50.....	78	SDWS22400DBMB.....	58
SD9112R500.....	62	SDW22638.....	79, 301	SDWS22400DB-R50.....	58
SD9212.....	322	SDW22638MB.....	79	SDWS22400DB-RC12.....	58
SD9212MB.....	62	SDW22638-R50.....	79	SDWS22500DB.....	58, 272, 273, 274, 276, 277, 278, 281
SD9212R100.....	62	SDWC15450.....	77, 295, 296, 297, 300	SDWS22500DBMB.....	58
SD9212R500.....	62	SDWC15450B-KT.....	77	SDWS22500DB-R50.....	58
SD10112.....	322	SDWC15450-KT.....	77	SDWS22500DB-RC12.....	58
SD10112MB.....	62	SDWC15600.....	77, 295, 296, 297, 300	SDWS22600DB.....	58, 272, 274, 276, 277, 278, 279, 281
SD10112R100.....	62	SDWC15600B-KT.....	77	SDWS22600DBMB.....	58
SD10112R500.....	62	SDWC15600-KT.....	77	SDWS22600DB-R50.....	58
SD10212.....	322	SDWC154503.....	295	SDWS22600DB-RC12.....	58
SD10212MB.....	62	SDWC156004.....	295	SDWS22800DB.....	58, 272, 276, 277, 281
SD10212R100.....	62	SDWC156005.....	295	SDWS22800DBMB.....	58
SD10212R500.....	62	SDWF2716-TUW.....	80, 306	SDWS22800DB-R50.....	58
SD91212.....	322	SDWF2720-TUW.....	80, 306	SDWS22800DB-RC12.....	58
SDS25112.....	61	SDWF2724-TUW.....	80, 306	SDWS22800DB-R50.....	58
SDS25112MB.....	61	SDWF2726-TUW.....	80, 306	SDWS22800DB-RC12.....	58
SDS25112-R25.....	61	SDWH19212.....	103	SDWS22900.....	282, 79
SDS25112SS.....	61	SDWH19300DB.....	59, 283	SDWS221000.....	281, 282, 79
SDS25112SS-R25.....	61	SDWH19300DBMB.....	59	SDWS221000DB.....	58, 272, 276, 277, 281
SDS25200.....	61, 318	SDWH19300DB-R50.....	59	SDWS221000DB-R50.....	58
SDS25200MB.....	61	SDWH19300DB-RC12.....	59	SDWS221000DBRC12.....	58
SDS25200-R25.....	61	SDWH19400DB.....	59, 283, 284, 285, 286, 287, 288, 289	SDWS221100.....	282, 79
SDS25200SS.....	61, 317	SDWH19400DBMB.....	59		
SDS25200SS-R25.....	61				

Alphabetical Index

SDWS221200.....	282, 79
SDWS221500.....	282, 79
SP5SND1.....	84
SP5SND5.....	84
SP5SNDB.....	84
SPS25344-KT.....	118
SS3DSC3BS.....	172, 177
SS3DSC3BS316.....	172, 177
SS3DSC212BS.....	172, 177
SS3DSC212BS316.....	172, 177
SSA8D.....	324
SSA8D5.....	102
SSA8DB.....	102
SSA8DD.....	102
SSA10D.....	324
SSA10D5.....	102
SSA10DB.....	102
SSA10DD.....	102
SSA16D.....	324
SSA16D5.....	102
SSA16DB.....	102
SSA16DD.....	102
SSDCL3S.....	172, 186
SSDCL3S316.....	186
SSDCL212S.....	172, 186
SSDHPD212S.....	172, 175
SSDHPD212SB.....	175
SSDTH2S.....	172, 176
SSDTH3S.....	172, 176
SSDTH212S.....	172, 176
SSDTH212SBR02.....	176
SSDTH212SBR03.....	176
SSDTH212SBR04.....	176
SSDTH212SGR02.....	176
SSDTH212SGR03.....	176
SSDTH212SRD02.....	176
SSDTH212STN02.....	176
SSDTH212STN03.....	176
SSDTH212STN04.....	176
SSDTH212SWH01.....	176
SSDTH212SWH02.....	176
SSDWP3S305.....	172, 174
SSDWP3S316.....	172, 174
SSDWP212S305.....	172, 174
SSDWP212S316.....	172, 174
SSFHSD112S1016.....	201
SSNA8.....	324
SSNA8D.....	102
SSNA8D5.....	102
SSNA8DB.....	102
SSNA10.....	324
SSNA10D.....	102
SSNA10D5.....	102
SSNA10DB.....	102
SSPC1BS1012.....	173, 192
SSPCSD1S1016.....	173, 198
SSPCSD1B1016-5K	126
SSPCULP1BS1012.....	173, 192
SSPCULPIB1012-5K.....	114
SSWSC2BS.....	172, 184
SSWSC134BS.....	172, 184
SSWSC212BS.....	172, 184
ST9.....	323
ST12.....	323
ST18.....	323
ST22.....	323
ST292.....	323
ST2115.....	323
ST2122.....	323
ST2215.....	323
ST6215.....	323
ST6224.....	323
ST6236.....	323

T

T2ACN1.....	85
T2ACN5.....	85
T2ACNB.....	85
T2CN1.....	86
T2CN5.....	86
T2CNB.....	86
T2FN1.....	88
T2FN5.....	88
T2FNB.....	88
T2KR5B.....	81
T2KR7B.....	81
T2KR51.....	81
T2KR55.....	81
T2KR71.....	81
T2KR75.....	81
T3ABN1.....	82
T3ABN5.....	82
T3ABNB.....	82
T3ACDRWWR1.....	84
T3ACDRWWR5.....	84
T3ACN1.....	85
T3ACN5.....	85
T3ACNB.....	85
T3CN1.....	86
T3CN5.....	86
T3CNB.....	86
T3FN1.....	88
T3FN5.....	88
T3FNB.....	88
T3KR5B.....	81
T3KR7B.....	81
T3KR51.....	81
T3KR55.....	81
T3KR71.....	81
T3KR75.....	81
T3PCS1.....	87
T3PCS5.....	87
T3PCSB.....	87
T3SN7B.....	95
T3SN71.....	95
T3SN75.....	95
T3SND1.....	84
T3SND5.....	84
T3SNDB.....	84
T4ABN1.....	82
T4ABN5.....	82
T4ABNB.....	82
T4ACN1.....	85
T4ACN5.....	85
T4ACNB.....	85
T4CN1.....	86
T4CN5.....	86
T4CNB.....	86
T4FN1.....	88
T4FN5.....	88
T4FNB.....	88
T4HACN1.....	85
T4HACN5.....	85
T4HACNB.....	85
T4KR5B.....	81
T4KR7B.....	81
T4KR51.....	81
T4KR55.....	81
T4KR71.....	81
T4KR75.....	81
T4PCS1.....	87
T4PCS5.....	87
T4PCSB.....	87
T4PTD1.....	91
T4PTD5.....	91
T4PTDB.....	91
T4SN7B.....	95

T4SN71.....	95
T4SN75.....	95
T4SND1.....	84
T4SND5.....	84
T4SNDB.....	84
T5ABN1.....	82
T5ABN5.....	82
T5ABNB.....	82
T5ACN1.....	85
T5ACN5.....	85
T5ACNB.....	85
T5CN1.....	86
T5CN5.....	86
T5CNB.....	86
T5FN1.....	88
T5FN5.....	88
T5FNB.....	88
T5FNX1.....	87
T5FNX5.....	87
T5FNXB.....	87
T5KR5B.....	81
T5KR7B.....	81
T5KR51.....	81
T5KR55.....	81
T5KR71.....	81
T5KR75.....	81
T5SN7B.....	95
T5SN71.....	95
T5SN75.....	95
T5SND1.....	84
T5SND5.....	84
T5SNDB.....	84
T6ABN1.....	82
T6ABN5.....	82
T6ABNB.....	82
T6ACN1.....	85
T6ACN5.....	85
T6ACNB.....	85
T6AKR1.....	81
T6AKR5.....	81
T6AKRB.....	81
T6APB1.....	90
T6APB5.....	90
T6APBB.....	90
T6CN1.....	86
T6CN5.....	86
T6CNB.....	86
T6FN1.....	88
T6FN5.....	88
T6FNB.....	88
T6FNX1.....	87
T6FNX5.....	87
T6FNXB.....	87
T06J050FXC.....	107
T06J050FXM.....	107
T06J050PXC.....	106
T06J050PXM.....	106
T06J075FXC.....	107
T06J075FXM.....	107
T06J075OXC.....	108
T06J075OXM.....	108
T06J075PXC.....	106
T06J075PXM.....	106
T06J100FXC.....	107
T06J100FXM.....	107
T06J100OXC.....	108
T06J100OXM.....	108
T06J100PXC.....	106
T06J100PXM.....	106
T6KR5B.....	81
T6KR7B.....	81
T6KR51.....	81
T6KR55.....	81
T6KR71.....	81

Alphabetical Index

T6KR75.....	81	T08C162WQM.....	109	T8SNDG5.....	93
T6PCS1.....	87	T08C200PAK.....	68	T8SNDGB.....	93
T6PCS5.....	87	T08C225WQC.....	109	T8SNDR1.....	93
T6PCSB.....	87	T08C225WQM.....	109	T8SNDR5.....	93
T6PSN1.....	92	T08C250PAK.....	68	T8SNDRB.....	93
T6PSN5.....	92	T8CN1.....	86	T8SNDT1.....	93
T6PSNB.....	92	T8CN5.....	86	T8SNDT5.....	93
T6PTD1.....	91	T8CNB.....	86	T8SNDTB.....	93
T6PTD5.....	91	T8CRD1.....	83	T8SNDW1.....	93
T6PTDB.....	91	T8CRD5.....	83	T8SNDW5.....	93
T6SN7B.....	95	T8CRDB.....	83	T8SNDWB.....	93
T6SN71.....	95	T8CRDG1.....	83	T8VTN1000.....	103
T6SN75.....	95	T8CRDG5.....	83	T9A150MCN.....	152
T6SND1.....	84	T8CRDGB.....	83	T9A250MCN.....	152
T6SND5.....	84	T8CRDR1.....	83	T9N150JNJ.....	148
T6SNDDB.....	84	T8CRDR5.....	83	T10A175X0C.....	89
T6SNDDB1.....	93	T8CRDRB.....	83	T10A175X0M.....	89
T6SNDDB5.....	93	T8CRDT1.....	83	T10A200X0C.....	89
T6SNDDBB.....	93	T8CRDT5.....	83	T10A200X07.....	89
T6SNDG1.....	93	T8CRDTB.....	83	T10A300CNB.....	146
T6SNDG5.....	93	T8FN1.....	88	T10A300CNJ.....	146
T6SNDGB.....	93	T8FN5.....	88	T10A300PNJ.....	143
T6SNDR1.....	93	T8FNB.....	88	T10A325B31.....	149
T6SNDR5.....	93	T8HPTD1.....	91	T10A325CNB.....	146
T6SNDRB.....	93	T8HPTD5.....	91	T10A325CNJ.....	146
T6SND5.....	93	T8HPTDB.....	91	T10A325P31.....	149
T6SND5S.....	93	T08J050PXC.....	106	T10A325T31.....	151
T6SND5SB.....	93	T08J050PXM.....	106	T10A350CNB.....	146
T6SNDT1.....	93	T08J075FXC.....	107	T10A350CNJ.....	146
T6SNDT5.....	93	T08J075FXM.....	107	T10A350PNJ.....	143
T6SNDTB.....	93	T08J075OXC.....	108	T10ABN1.....	82
T6SNDW1.....	93	T08J075OXM.....	108	T10ABN5.....	82
T6SNDW5.....	93	T08J075PXC.....	106	T10ABNB.....	82
T6SNDWB.....	93	T08J075PXM.....	106	T10ACN1.....	85
T7ABN1.....	82	T08J100FXC.....	107	T10ACN5.....	85
T7ABN5.....	82	T08J100FXM.....	107	T10ACNB.....	85
T7ABNB.....	82	T08J100OXC.....	108	T10AKR1.....	81
T7ACN1.....	85	T08J100OXM.....	108	T10AKR5.....	81
T7ACN5.....	85	T08J100PXC.....	106	T10AKRB.....	81
T7ACNB.....	85	T08J100PXM.....	106	T10APB1.....	90
T07C162PAK.....	71	T08J125FXC.....	107	T10APB5.....	90
T07C225PAK.....	71	T08J125FXM.....	107	T10APBB.....	90
T07C300PAK.....	71	T08J125OXC.....	108	T10C250DTP.....	67
T7CN1.....	86	T08J125OXM.....	108	T10C250PAK.....	68
T7CN5.....	86	T08J125PXC.....	106	T10C300DTP.....	67
T7CNB.....	86	T08J125PXM.....	106	T10C300PAK.....	68
T7KR5B.....	81	T08J150FXC.....	107	T10C350PAK.....	68
T7KR7B.....	81	T08J150FXM.....	107	T10CN1.....	86
T7KR51.....	81	T08J150OXC.....	108	T10CN5.....	86
T7KR55.....	81	T08J150OXM.....	108	T10CNB.....	86
T7KR71.....	81	T8KR5B.....	81	T10CRD1.....	83
T7KR75.....	81	T8KR7B.....	81	T10CRD5.....	83
T7SN7B.....	95	T8KR51.....	81	T10CRDB.....	83
T7SN71.....	95	T8KR55.....	81	T10CRDG1.....	83
T7SN75.....	95	T8KR71.....	81	T10CRDG5.....	83
T7SND1.....	84	T8KR75.....	81	T10CRDGB.....	83
T7SND5.....	84	T8PCS1.....	87	T10CRDR1.....	83
T7SNDDB.....	84	T8PCS5.....	87	T10CRDR5.....	83
T8ABN1.....	82	T8PCSB.....	87	T10CRDRB.....	83
T8ABN5.....	82	T8PSN1.....	92	T10CRDT1.....	83
T8ABNB.....	82	T8PSN5.....	92	T10CRDT5.....	83
T8ACN1.....	85	T8PSNB.....	92	T10CRDTB.....	83
T8ACN5.....	85	T8PTD1.....	91	T10FNB.....	88
T8ACNB.....	85	T8PTD5.....	91	T10FN5.....	88
T8AKR1.....	81	T8PTDB.....	91	T10FNB.....	88
T8AKR5.....	81	T8SN7B.....	95	T10HPTD1.....	91
T8AKRB.....	81	T8SN71.....	95	T10HPTD5.....	91
T8APB1.....	90	T8SN75.....	95	T10HPTDB.....	91
T8APB5.....	90	T8SND1.....	84	T10J050PXC.....	106
T8APBB.....	90	T8SND5.....	84	T10J050PXM.....	106
T08C125PAK.....	68	T8SNDDB.....	84	T10J075OXC.....	108
T08C125WQC.....	109	T8SNDDB1.....	93	T10J075OXM.....	108
T08C125WQM.....	109	T8SNDDB5.....	93	T10J075PXC.....	106
T08C162PAK.....	68	T8SNDDBB.....	93	T10J075PXM.....	106
T08C162WQC.....	109	T8SNDG1.....	93	T10J100FXC.....	107

Alphabetical Index

T10J100FXM	107	T12A237B31	149	T13A225SNJ	139
T10J100OXC	108	T12A237CNB	146	T13A250IPBP	137
T10J100OXM	108	T12A237CNJ	146	T13A250IPC	137
T10J100PXC	106	T12A237P31	149	T13A250SNJ	139
T10J100PXM	106	T12A237T31	151	T14J100OXC	108
T10J125FXC	107	T12A250PNB	143	T14J100OXM	108
T10J125FXM	107	T12A250PNJ	143	T14J100PXC	106
T10J125OXC	108	T12ABN1	82	T14J100PXM	106
T10J125OXM	108	T12ABN5	82	T14J150OXC	108
T10J125PXC	106	T12ABNB	82	T14J150OXM	108
T10J125PXM	106	T12ACN1	85	T14J150PXC	106
T10J150FXC	107	T12ACN5	85	T14J150PXM	106
T10J150FXM	107	T12ACNB	85	T14J200OXC	108
T10J150OXC	108	T12AKR1	81	T14J200OXM	108
T10J150OXM	108	T12AKR5	81	T14J200PXC	106
T10J200FXC	107	T12AKRB	81	T14J200PXM	106
T10J200FXM	107	T12APB1	90	T15N125SFN	158
T10KR7B	81	T12APB5	90	T15N150FNB	154
T10KR71	81	T12APBB	90	T15N150FNJ	154
T10KR75	81	T12CN1	86	T15N150SFB	158
T10N062SWC	119	T12CN5	86	T15N150SFN	158
T10n062SWM	119	T12CNB	86	T15N200FNB	154
T10PSN1	92	T12CRD1	83	T15N200FNJ	154
T10PSN5	92	T12CRD5	83	T15N200SFB	158
T10PSNB	92	T12CRDB	83	T15N200SFN	158
T10PTD1	91	T12CRDG1	83	T15N250FNB	154
T10PTD5	91	T12CRDG5	83	T15N250FNJ	154
T10PTDB	91	T12CRDGB	83	T15N250SFB	158
T10S350CNB	147	T12CRDR1	83	T15N250SFN	158
T10S350CNJ	147	T12CRDR5	83	T16ABN1	82
T10SND1	84	T12CRDRB	83	T16ABN5	82
T10SND5	84	T12CRDT1	83	T16ABNB	82
T10SNDB	84	T12CRDT5	83	T16ACN1	85
T10SNDB1	93	T12CRDTB	83	T16ACN5	85
T10SNDB5	93	T12FN1	88	T16ACNB	85
T10SNDBB	93	T12FN5	88	T16AKR1	81
T10SNDG1	93	T12FNB	88	T16AKR5	81
T10SNDG5	93	T12J100OXC	108	T16AKRB	81
T10SNDGB	93	T12J100OXM	108	T16APB1	90
T10SNDR1	93	T12J100PXC	106	T16APB5	90
T10SNDR5	93	T12J100PXM	106	T16APBB	90
T10SNDRB	93	T12J150OXC	108	T16CN1	86
T10SNDT1	93	T12J150OXM	108	T16CN5	86
T10SNDT5	93	T12J150PXC	106	T16CNB	86
T10SNDTB	93	T12J150PXM	106	T16CRD1	83
T10SNDW1	93	T12J200OXC	108	T16CRD5	83
T10SNDW5	93	T12J200OXM	108	T16CRDB	83
T10SNDWB	93	T12J200PXC	106	T16CRDG1	83
T11A100RNJ	141	T12J200PXM	106	T16CRDG5	83
T11A125RNJ	141	T12KR7B	81	T16CRDGB	83
T11A150RNJ	141	T12KR71	81	T16CRDR1	83
T11A175RNJ	141	T12KR75	81	T16CRDR5	83
T11A250CNB	146	T12N062SWC	119	T16CRDRB	83
T11A250CNJ	146	T12N062SWM	119	T16CRDT1	83
T11A300B31	149	T12PTD1	91	T16CRDT5	83
T11A300CNB	146	T12PTD5	91	T16CRDTB	83
T11A300CNJ	146	T12PTDB	91	T16FN1	88
T11A300P31	149	T12S200CNB	147	T16FN5	88
T11A300PNJ	143	T12S200CNJ	147	T16FNB	88
T11A300T31	151	T12S250CNB	147	T16HPTD1	91
T11A325CNB	146	T12S250CNJ	147	T16HPTD5	91
T11A325CNJ	146	T12SND1	84	T16HPTDB	91
T11A325PNJ	143	T12SND5	84	T16KR7B	81
T11N125RNJ	142	T12SNDB	84	T16KR41	81
T11N150RNJ	142	T13A150IPBP	137	T16KR45	81
T11N175RNJ	142	T13A150IPC	137	T16N075N11	163
T11S300CNB	147	T13A150SNJ	139	T16N075P51	160
T11S300CNJ	147	T13A175IPBP	137	T16N100N13	163
T11S325CNB	147	T13A175IPC	137	T16N100P53	160
T11S325CNJ	147	T13A175SNJ	139	T16N125FNB	155
T12A200CNB	146	T13A200IPBP	137	T16N125FNJ	155
T12A200CNJ	146	T13A200IPC	137	T16N125N15	163
T12A200PNB	143	T13A200SNJ	139	T16N125PFB	153
T12A200T31	151	T13A225IPBP	137	T16N125PFN	153
T12A225PNJ	143	T13A225IPC	137	T16N150FNB	155

Alphabetical Index

T16N150FNJ	155	T40CN5	86	T07225FCG	70
T16N150N17	163	T40CNB	86	T07225FCI	70
T16N150PFB	153	T60ACN1	85	T07225FCT	70
T16N150PFN	153	T60ACN5	85	T07225FCW	70
T16N175N19	163	T60ACNB	85	T07225FJG	70
T16N200FNB	155	T60APB1	90	T07225FJI	70
T16N200FNJ	155	T60APB5	90	T07225FJT	70
T16N200N21	163	T60APBB	90	T07225FJW	70
T16N200PFB	153	T60CN1	86	T07225FTB	73
T16N200PFN	153	T60CN5	86	T07225FTP	73
T16N250FNB	155	T60CNB	86	T07225FVWP	65
T16N250FNJ	155	T70ACN1	85	T07225WCI	65
T16N250PFB	153	T70ACN5	85	T07225WJI	65
T16N250PFN	153	T70ACNB	85	T07225WP1	65
T16PTD1	91	T70APB1	90	T07225WP5	65
T16PTD5	91	T70APB5	90	T07225WPB	65
T16PTDB	91	T70APBB	90	T07225WPP	65
T16SND1	84	T70CN1	86	T07300FB1	71
T16SND5	84	T70CN5	86	T07300FB5	71
T16SNDB	84	T70CNB	86	T07300FBB	71
T18N037FNJ	156	T210ARN1	97	T07300FBH	71
T18N050FNJ	156	T210ARN5	97	T07300FVP	65
T18N062FNJ	156	T210ARNB	97	T07300WJI	65
T18N062L10	162	T310ARN1	97	T07300WP1	65
T18N075FNB	156	T310ARN5	97	T07300WPB	65
T18N075FNJ	156	T310ARNB	97	T07300WPP	65
T18N075L11	162	T311ARN1	97	T7510ARN1	97
T18N100FNB	156	T311ARN5	97	T7510ARN5	97
T18N100FNJ	156	T311ARNB	97	T7510ARNB	97
T18N100L13	162	T410ARN1	97	T08100HDUC	111
T18N112L14	162	T410ARN5	97	T08100HDUM	111
T18N125FNB	156	T410ARNB	97	T08125DB1	68
T18N125FNJ	156	T411ARN1	97	T08125DB5	68
T18N125L15	162	T411ARN5	97	T08125DBB	68
T18N150FNB	156	T411ARNB	97	T08162DB1	68
T18N150FNJ	156	T510ARN1	97	T08162DB5	68
T18N150L17	162	T510ARN5	97	T08162DBB	68
T18N175FNJ	156	T510ARNB	97	T08162WP1	64
T18N200FNB	156	T511ARN1	97	T08162WPB	64
T18N200FNJ	156	T511ARN5	97	T08162WPP	64
T20ABN1	82	T511ARNB	97	T08200DB1	68
T20ABN5	82	T610ARN1	97	T08200DB5	68
T20ABNB	82	T610ARN5	97	T08200DBB	68
T20ACN1	85	T610ARNB	97	T08200WP1	64
T20ACN5	85	T611ARN1	97	T08200WP5	64
T20ACNB	85	T611ARN5	97	T08200WPB	64
T20CN1	86	T611ARNB	97	T08200WPP	64
T20CN5	86	T810ARN1	97	T08250DB1	68
T20CNB	86	T810ARN5	97	T08250DB5	68
T20FN1	88	T810ARNB	97	T08250DBB	68
T20FN5	88	T1010ARN1	97	T08250FBK	72
T20FNB	88	T1010ARN5	97	T08250FCA	72
T20HPTD5	91	T1010ARNB	97	T08250FCM	72
T20HPTDB	91	T07162FB1	71	T08250FCW	72
T20PTD1	91	T07162FB5	71	T08250FJA	72
T20PTD5	91	T07162FBB	71	T08250FJK	72
T20PTDB	91	T07162FBH	71	T08250FJM	72
T20SND1	84	T07162FCG	70	T08250FJW	72
T20SND5	84	T07162FCI	70	T08250FT1	73
T20SNDB	84	T07162FCT	70	T08250FT5	73
T25N112SWC	119	T07162FCW	70	T08250FTB	73
T25N112SWM	119	T07162FJG	70	T08250FZC	72
T30ACN1	85	T07162FJI	70	T08250FZJ	72
T30ACN5	85	T07162FJT	70	T08250WPF1	64
T30ACNB	85	T07162FJW	70	T08250WPF5	64
T30CN1	86	T07162FWP	65	T08250WPFB	64
T30CN5	86	T07162WJI	65	T08300WPF1	64
T30CNB	86	T07162WP1	65	T08300WPF5	64
T40ACN1	85	T07162WPS	65	T08300WPFB	64
T40ACN5	85	T07162WPB	65	T09100HWAC	110
T40ACNB	85	T07162WPP	65	T09100HWAM	110
T40APB1	90	T07225FB1	71	T09100HWHC	110
T40APB5	90	T07225FB5	71	T09100HWHM	110
T40APBB	90	T07225FBB	71	T09150HWAC	110
T40CN1	86	T07225FBH	71	T09150HWAM	110

Alphabetical Index

T09150HWHC.....	110	T12400DB5.....	68	V	
T09150HWHM.....	110	T12400DBB.....	68	VTOR.....	323
T09200HWAC.....	110	T12400HDUC.....	111	W	
T09200HWAM.....	110	T12400HDUM.....	111	WDPLUG2M.....	121
T09200HWHC.....	110	T12400WP1.....	64	WDPLUG-100.....	121
T09200HWHM.....	110	T12400WP5.....	64	WSC112S.....	172, 193
T10200DB1.....	68	T12400WPB.....	64	WSC114S-17.....	172, 193
T10200DB5.....	68	T12400WPP.....	64	WSCD3S.....	172, 185
T10200DBB.....	68	T12450DB1.....	68	WSCD212S.....	172, 185
T10200WP1.....	64	T12450DB5.....	68	WSCG134S.....	172, 184
T10200WP5.....	64	T12450DBB.....	68	WSCLT134S.....	172, 193
T10200WPB.....	64	T12450WP1.....	64	WSC212S.....	172, 185
T10250DB1.....	68	T12450WP5.....	64	WSF1LRVS.....	173, 201
T10250DB5.....	68	T12450WPB.....	64	WSF134LRVS.....	173, 201
T10250DBB.....	68	T12500DB1.....	68	WSHL134S7.....	172, 190
T10250DBB.....	68	T12500DB5.....	68	WSNTL2LS.....	188, 172
T10250DT1.....	67	T12500DBB.....	68	WSNTL2LS-17.....	172, 188
T10250DT5.....	67	T12500WP1.....	64	WSNTL3S.....	172, 188, 310
T10250DTB.....	67	T12500WP5.....	64	WSNTL134S.....	172, 188
T10250DXB.....	75	T12500WPB.....	64	WSNTL212S.....	172, 188
T10250DXP.....	75	T12550DB1.....	68	WSNTLG2S.....	172, 175
T10250WP1.....	64	T12550DB5.....	68	WSNTLG3S.....	172, 175
T10250WP5.....	64	T12550DBB.....	68	WSNTLG212S.....	172, 175
T10250WPB.....	64	T12600DB1.....	68	WSNTLQ3S.....	172, 175
T10250WPP.....	64	T12600DB5.....	68	WSNTLQ212S.....	172, 175
T10300DB1.....	68	T12600DBB.....	68		
T10300DB5.....	68	T14300DB1.....	68	X	
T10300DBB.....	68	T14300DB5.....	68	X1B1016-4K.....	125
T10300DT1.....	67	T14300DBB.....	68	X1B1214-3.5K.....	125
T10300DT5.....	67	T14350DB1.....	68	X1S1016.....	173, 197
T10300DTB.....	67	T14350DB5.....	68	X1S1214.....	173, 197
T10300DXB.....	75	T14350DBB.....	68	X34B1016-5K.....	125
T10300DXP.....	75	T14400DB1.....	68	X114B1224-2.5K.....	125
T10300WP1.....	64	T14400DB5.....	68	X114S1224.....	197
T10300WP5.....	64	T14400DBB.....	68	XEQ34B1016.....	271, 312
T10300WPB.....	64	T14400WPP.....	64	XEQ34B1016C.....	122
T10300WPP.....	64	T14400WP5.....	64	XEQ34B1016M.....	122
T10350DB1.....	68	T14400WPB.....	64	XQ1B1016-4K.....	125
T10350DB5.....	68	T14400WPP.....	64	XQ1B1214-3.5K.....	125
T10350DBB.....	68	T14500DB1.....	68	XQ1S1016.....	173, 197
T10350DBB.....	68	T14500DB5.....	68	XQ1S1214.....	173, 197
T10350WP1.....	64	T14500DBB.....	68	XQ78B1224-3K.....	125
T10350WPB.....	64	T14600DB1.....	68	XQ78S1224.....	173, 271, 197
T10350WPP.....	64	T14600DB5.....	68	XQ112B1224-2K.....	125
T10450WPCM.....	64	T14600DBB.....	68	XQ112S1224.....	173, 197
T12100HDUC.....	111	TB1445S.....	173, 194	XQ114B1224-2.5K.....	125
T12100HDUM.....	111	TB1460S.....	173, 194	XQ114S1224.....	173, 197
T12100XOC.....	112	TB1475S.....	173, 194	XU34B1016-5K.....	125
T12100XOM.....	112	TBG1245S.....	194		
T12150HDUC.....	111	TBG1260S.....	194	Z	
T12150HDUM.....	111	TBG1445S.....	173, 194	Z25CWWNC.....	118
T12150XOC.....	112	TBG1460S.....	173, 194		
T12150XOM.....	112	TBG1475S.....	173, 194		
T12200HDUC.....	111	TBP1245S.....	194		
T12200HDUM.....	111	TBP1260S.....	194		
T12200XOC.....	112	TBP1460S.....	194		
T12200XOM.....	112	TBP1475S.....	194		
T12250DB1.....	68	THASR/L29.....	323		
T12250DB5.....	68	THASR/L29-2.....	323		
T12250DBB.....	68	THASR/L422.....	323		
T12250HDUC.....	111	TOOLCASE-LG.....	265		
T12250HDUM.....	111	TP15.....	323		
T12250WP1.....	64	TP35.....	323		
T12250WP5.....	64	TP37.....	323		
T12250WPB.....	64	TP39.....	323		
T12300DB1.....	68	TP45.....	323		
T12300DB5.....	68	TP47.....	323		
T12300DBB.....	68	TP49.....	323		
T12300HDUC.....	111	TP57.....	323		
T12300HDUM.....	111	TP311.....	323		
T12350DB1.....	68	TP411.....	323		
T12350DB5.....	68	TPA37.....	323		
T12350DBB.....	68	TPA39.....	323		
T12350WP1.....	64	TPA57.....	323		
T12350WP5.....	64	TPO15.....	120		
T12350WPB.....	64				
T12400DB1.....	68				

The Anatomy of Performance

Sinks in to any great project

Make way for a smooth finish

We recommend a test drive

Easy driving from here on

Start fast with no pre-drilling

The Strong-Drive® SDWS **TIMBER** screw is like no other. Its patented tip ensures fast starts, reduces torque and eliminates pre-drilling. The bold thread design provides superior holding power while the large, low-profile head eliminates washers. All of this and a double-barrier coating to resist corrosion – now that's a fastener engineered to perform.

One fastener for multiple wood projects with higher shear loads. Learn more by calling (800) 999-5099 or visiting www.strongtie.com/sdws.

Code Listed:
IAPMO UES ER-192

SIMPSON
Strong-Tie

®