



Operating Instructions and Parts Manual 20" Variable Speed Drill Press

Models: JDP-20VS-1, JDP-20VS-3, JDP-20VST



JDP-20VST

JDP-20VS

JET
427 New Sanford Road
LaVergne, Tennessee 37086
Ph.: 800-274-6848
www.jettools.com

Part No. M-354230
Edition 2 11/2016
Copyright © 2016 JET



1.0 IMPORTANT SAFETY INSTRUCTIONS

- Misuse of this machine can cause serious injury.
- For safety, machine must be set up, used and serviced properly.
- Read, understand and follow instructions in the Operating Instructions and Parts Manual which was shipped with your machine.

When setting up machine:

- Always avoid using machine in damp or poorly lighted work areas.
- Always be sure the machine support is securely anchored to the floor or the work bench.

When using machine:

- Always wear safety glasses with side shields (See ANSI Z87.1)
- Never wear loose clothing or jewelry.
- Never overreach—you may slip and fall.

When servicing machine:

- Always disconnect the machine from its electrical supply while servicing.
- Always follow instructions in Operating Instructions and Parts Manual when changing accessory tools or parts.
- Never modify the machine without consulting JET.

You—the stationary power tool user—hold the key to safety.

Read and follow these simple rules for best results and full benefits from your machine. Used properly, JET machinery is among the best in design and safety. However, any machine used improperly can be rendered inefficient and unsafe. It is absolutely mandatory that those who use our products be properly trained in how to use them correctly. They should read and understand the Operating Instructions and Parts Manual as well as all labels affixed to the machine. Failure to follow all of these warnings can cause serious injuries.

1.1 Machinery general safety warnings

1. Always wear protective eye wear when operating machinery. Eye wear shall be impact resistant, protective safety glasses with side shields which comply with ANSI Z87.1 specifications. Use of eye wear which does not comply with ANSI Z87.1 specifications could result in severe injury from breakage of eye protection.
2. Wear proper apparel. No loose clothing or jewelry which can get caught in moving parts. Rubber soled footwear is recommended for best footing.
3. Do not overreach. Failure to maintain proper working position can cause you to fall into the machine or cause your clothing to get caught, pulling you into the machine.
4. Keep guards in place and in proper working order. Do not operate the machine with guards removed.
5. Avoid dangerous working environments. Do not use stationary machine tools in wet or damp locations. Keep work areas clean and well lit.
6. Avoid accidental starts by being sure the start switch is "OFF" before plugging in the machine.
7. Never leave the machine running while unattended. Machine shall be shut off whenever it is not in operation.
8. Disconnect electrical power before servicing. Whenever changing accessories or general maintenance is done on the machine, electrical power to the machine must be disconnected before work is done.
9. Maintain all machine tools with care. Follow all maintenance instructions for lubricating and the changing of accessories. No attempt shall be made to modify or have makeshift repairs done to the machine. This not only voids the warranty but also renders the machine unsafe.
10. Machinery must be anchored to the floor.
11. Secure work. Use clamps or a vise to hold work, when practical. It is safer than using your hands and it frees both hands to operate the machine.
12. Never brush away chips while the machine is in operation.
13. Keep work area clean. Cluttered areas invite accidents.
14. Remove adjusting keys and wrenches before turning machine on.

15. Use the right tool. Don't force a tool or attachment to do a job for which it was not designed.
16. Use only recommended accessories and follow manufacturer's instructions pertaining to them.
17. Keep hands in sight and clear of all moving parts and cutting surfaces.
18. All visitors should be kept at a safe distance from the work area. Make workshop completely safe by using padlocks, master switches, or by removing starter keys.
19. Know the tool you are using — its application, limitations, and potential hazards.
20. **CALIFORNIA PROPOSITION 65 WARNING:** This product contains chemicals known to the State of California to cause cancer, or birth defects or other reproductive harm.
21. This product, when used for welding, cutting, or working with metal, produces fumes, gases, or dusts which contain chemicals known to the State of California to cause birth defects and, in some cases, cancer. (California Health and Safety Code Section 25249.5 et seq.)
22. The installer shall follow local regulations and National Electrical Code, ANSI/NFPA 70 installation requirements.
23. Clamp workpiece or brace against column to prevent rotation.
24. MAKE WORKSHOP KID PROOF with padlocks, master switches, or by removing starter keys.
25. NEVER STAND ON TOOL Serious injury could occur if the tool is tipped or if the cutting tool is unintentionally contacted.
26. CHECK DAMAGED PARTS. Before further use of the too., a guard or other part that is damaged should be carefully checked to determine that it will operate properly and perform its intended function – check for alignment of moving parts, binding of moving parts, breakage of parts, mounting, and any other conditions that may affect its operation. A guard or other part that is damaged should be properly repaired or replaced.
27. Grounding instruction: This tool should be connected to a grounded metal permanent wiring system; or to a system having an equipment-grounding conductor.

Familiarize yourself with the following safety notices used in this manual:

CAUTION This means that if precautions are not heeded, it may result in minor injury and/or possible machine damage.

WARNING This means that if precautions are not heeded, it may result in serious or even fatal injury.

1.2 General electrical cautions

This drill press should be grounded in accordance with the National Electrical Code and local codes and ordinances. This work should be done by a qualified electrician. The saw must be grounded to protect the user from electrical shock.

Wire sizes

Caution: For circuits which are far away from the electrical service box, the wire size must be increased in order to deliver ample voltage to the motor. To minimize power losses and to prevent motor overheating and burnout, the use of wire sizes for branch circuits or electrical extension cords according to Table 2 (sect. 6.4) is recommended.

1.3 Safety instructions for drill presses

1. All work shall be secured using either clamps or a vise to the drill press table. It is unsafe to use your hands to hold any workpiece being drilled.
2. Drill press head and table shall be securely locked to the column before operating the drill press. This must always be checked prior to starting the machine.
3. Always use the correct tooling. Tooling shall always be maintained and properly sharpened. All tooling must be run at the proper speeds and feeds as they apply to the job. Use only recommended accessories and follow those manufacturer's instructions pertaining to them. Tooling shall not be forced in to any work piece but fed according to the proper specifications. Failure to follow these instructions will not only ruin the tooling as well as the machine, but can cause serious injury.
4. Never brush away any chips while the machine is in operation. All clean up should be done when the machine is stopped.
5. Keep hands in sight. Do not put hands or fingers around, on, or below any rotating cutting tools.
6. Leather safety gloves should be used when handling any sharp objects or cutting tools. See A, Figure 1-1.
7. Always wear protective eye wear when operating, servicing or adjusting machinery. Eyewear shall be impact resistant, protective safety glasses with side shields complying with ANSI Z87.1 specifications. Use of eye wear which does not comply with ANSI Z87.1 specifications could result in severe injury from breakage of eye protection. B, Figure 1-1.
8. When drilling in material which causes dust, a dust mask shall be worn. See C, Figure 1-1.
9. Avoid contact with coolant, especially guarding the eyes.
10. Non-slip footwear and safety shoes are recommended. See D, Figure 1-1.
11. Wear ear protectors (plugs or muffs) during extended periods of operation. See E, Figure 1-1.

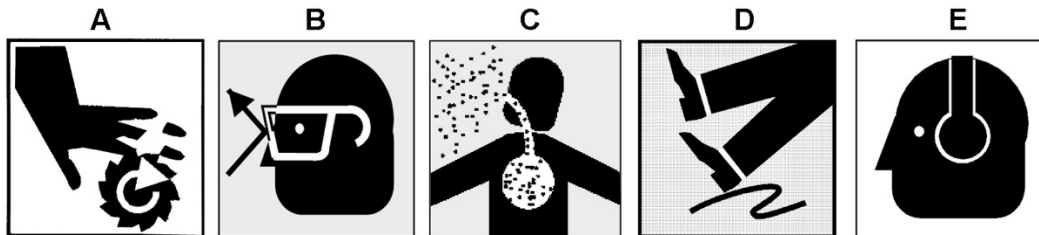

Figure 1-1

SAVE THESE INSTRUCTIONS

2.0 About this manual

This manual is provided by JET, covering the safe operation and maintenance procedures for a JET Model JDP-20VS series Drill Press. This manual contains instructions on installation, safety precautions, general operating procedures, maintenance instructions and parts breakdown. Your machine has been designed and constructed to provide consistent, long-term operation if used in accordance with the instructions as set forth in this document.

If there are questions or comments, please contact your local supplier or JET. JET can also be reached at our web site: www.jettools.com.

Retain this manual for future reference. If the machine transfers ownership, the manual should accompany it.

⚠ WARNING Read and understand the entire contents of this manual before attempting assembly or operation! Failure to comply may cause serious injury!

Register your product using the mail-in card provided, or register online: <http://www.jettools.com/us/en/service-and-support/warranty/registration/>

3.0 Table of Contents

Section	Page
1.0 IMPORTANT SAFETY INSTRUCTIONS	2
1.1 Machinery general safety warnings	2
1.2 General electrical cautions	3
1.3 Safety instructions for drill presses	4
2.0 About this manual	4
3.0 Table of Contents	5
4.0 Specifications for JDP-20VS series Drill Press	6
4.1 Mounting hole centers (all models)	7
5.0 Set-Up and Assembly	8
5.1 Shipping contents	8
5.2 Securing base	8
5.3 Raising head	8
6.0 Electrical Connections	9
6.1 GROUNDING INSTRUCTIONS	9
6.2 Electrical cabinet access (JDP-20VST only)	9
6.3 Voltage conversion (JDP-20VS-1/3 only)	9
6.4 Extension cords	9
7.0 Operating controls	10
7.1 JDP-20VS-1/3 controls	10
7.2 JDP-20VST controls	10
8.0 Adjustments	10
8.1 Depth stop	10
8.2 Table adjustment	11
8.3 Tool installation and removal	11
8.4 Speed pickup adjustment	11
8.5 Spindle return spring adjustment	11
8.6 Coolant pump (optional)	12
9.0 Operation	12
9.1 Operating precautions	12
9.2 Drilling recommendations	12
10.0 User-maintenance	13
10.1 Drive belt replacement	13
10.2 Motor replacement	13
10.3 Lubrication	13
10.4 Additional servicing	13
11.0 Coolant system (optional)	14
11.1 Coolant system installation	14
12.0 Troubleshooting JDP-20VS series Drill Press	15
13.0 Replacement Parts	15
13.1.1 Drill Head – Manual Speed Control (JDP-20VS-1/3) – Exploded View	16
13.1.2 Drill Head – Manual Speed Control (JDP-20VS-1/3) – Parts List	17
13.2.1 Drill Head – Two Speed Control (JDP20VST) – Exploded View	19
13.2.2 Drill Head – Two Speed Control (JDP20VST) – Parts List	20
13.3.1 Spindle Components (All Models) – Exploded View	22
13.3.2 Spindle Components (All Models) – Parts List	23
13.4.1 Safety Shield Assembly (All Models) – Exploded View	24
13.4.2 Safety Shield Assembly (All Models) – Parts List	24
13.5.1 Table and Base Assembly (All Models) – Exploded View	25
13.5.2 Table and Base Assembly (All Models) – Parts List	26
14.0 Electrical connections	28
14.1 JDP-20VS-1 and JDP-20VS-3 wiring diagram	28
14.2 JDP20VST wiring diagram	29
15.0 Warranty and Service	30

4.0 Specifications for JDP-20VS series Drill Press

Model number	JDP-20VS-1	JDP-20VS-3	JDP-20VST
Stock number	354230	354231	354240
Motor and Electricals			
Motor type	TEFC induction		
Horsepower	2 HP (1.5kW)		
Phase	1	3	3
Voltage	115/230 V (prewired 115V)	230/460 V (prewired 230V)	230 V only
Cycle	60 Hz		
Listed FLA (full load amps)	25/13	7/3.5	7/6.6
Motor speed	1720 RPM		1720/850 RPM
Power cable	SJT 12AWG, 6 ft.	AWM 14AWG, 4 ft.	SJT 14AWG, 6 ft.
Main Power plug	Not provided		
Work light	6W, 12V DC, input 110V AC		
Work light power cable	SVT 18AWG, 6 ft. with 110V plug		SVT 18AWG (to box)
Power transfer	Belts		
Gear ratio	(center pulley) 27T / 62T (spindle)		
Recommended overcurrent protection ¹	30A (115V) 15A (230V)	15A	15A
Capacities			
Drills to center of circle	20 in. (508 mm)		
Drilling capacity, cast iron	1-1/4 in. (31.8 mm)		
Drilling capacity, mild steel	1 in. (25.4 mm)	1-3/8 in. (35 mm)	
Tapping capacity, cast iron	n/a	3/4 in. (19 mm)	
Tapping capacity, mild steel	n/a	5/8 in. (15.9 mm)	
Spindle to table distance, maximum	30-1/4 in. (768.4 mm)		
Spindle to base distance	43-1/2 in. (1105 mm)		
Spindle to column distance	10-7/16 in. (265 mm)		
Coolant capacity (optional)	2 gal. (7.6 L)		
Spindle			
Spindle taper	MT-3		
Number of spindle speeds	Variable		
Spindle speed range	300 – 2,000 RPM		150 – 2,000 RPM
Spindle travel	6 in. (152.4 mm)		
Rotation	Fwd/rev		
Table and Column			
Table size LxW	22 x 18-3/4 in. (559 x 476.3 mm)		
Table working surface	18-1/8 x 14-3/4 in. (460.4 x 375 mm)		
Table effective travel (w/o rack adjustment)	15 in. (381 mm)		
Table max. travel (with rack adjustment)	20 in. (508 mm)		
Number of T-slots	3		
T-slot size	5/8 in. (16 mm)		
T-slot centers	3-3/4 in. (95 mm)		
Table weight capacity	154 lbs. (70 kg)		
Column diameter	4-1/2 in. (114.3 mm)		
Base			
Base size	27 x 19 in. (686 x 482.6 mm)		
Base working surface	15 x 12 in. (380 x 304mm)		
Number of T-slots	2		
T-slot size	5/8 in. (16 mm)		

	JDP-20VS-1	JDP-20VS-3	JDP-20VST
Main materials			
Head	cast iron		
Table and Base	cast iron		
Spindle and Quill	steel/cast iron		
Column	steel		
Dimensions			
Assembled machine dimensions LxWxH	38.18 x 27.16 x 79.52 in. (970 x 690 x 2020 mm)		
Shipping dimensions LxWxH	37 x 25.5 x 75 in. (940 x 648 x 1905 mm)		
Weights			
Net weight	685 lbs. (311 kg)		
Shipping weight	780 lbs. (354 kg)		

Table 1

¹ Subject to local and national electrical codes.

² The specified values are emission levels and are not necessarily to be seen as safe operating levels. As workplace conditions vary, this information is intended to allow the user to make a better estimation of the hazards and risks involved only.

L = length, W = width, H = height

n/a = not applicable

The above specifications were current at the time this manual was published, but because of our policy of continuous improvement, JET reserves the right to change specifications at any time and without prior notice, without incurring obligations.

4.1 Mounting hole centers (all models)

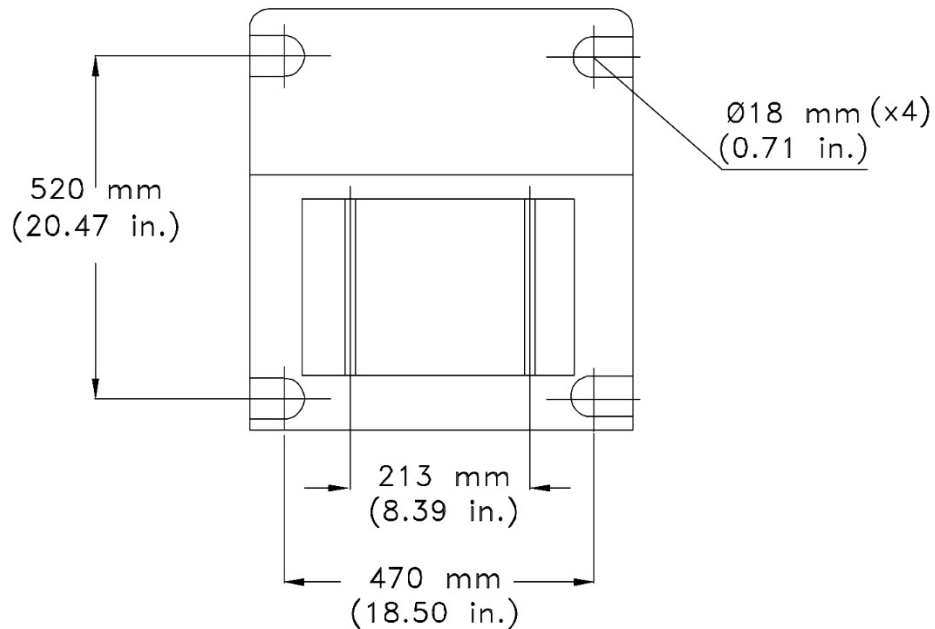

Figure 4-1: machine base mounting

⚠WARNING Read and understand the entire contents of this manual before attempting set-up or operation! Failure to comply may cause serious injury.

5.0 Set-Up and Assembly

Inspect contents of crate for shipping damage. Report any damage immediately to your distributor and shipping agent. Do not discard any shipping material until drill press is assembled and running properly.

Remove any fasteners holding drill press to pallet. Lift drill press with forklift or hoist with straps. (Note: Lifting point is beneath head and next to column.) Make sure coolant hose, handles, etc. are clear of forks or straps when lifting. **Lifting equipment must be properly rated for weight of drill press.**

Locate the machine on a solid, level floor, preferably concrete. Area should have good overhead lighting and ventilation. (Refer to OSHA regulations for specific information about using drill presses in industrial environments.) The drill press should be level and rest solidly on floor. Place shims below base as needed to achieve level.

Exposed metal surfaces have been given a protective coating. Remove this with a soft cloth and a cleaner-degreaser or kerosene. Do not use gasoline, paint thinner or acetone, as these may damage painted surfaces. Do not use an abrasive pad, as it may scratch polished surfaces.

Coat all machined surfaces with a light coat of oil to inhibit rust.

5.1 Shipping contents

- 1 Drill press
- 1 Crank handle
- 1 Socket wrench
- 1 Drift key
- 1 Operating and parts manual
- 1 Product registration card

5.2 Securing base

It is strongly recommended that drill press be secured to floor. The drill press base has four mounting slots; see Figure 4-1. When securing base to floor, apply even torque to the fasteners to prevent distortion of base.

5.3 Raising head

The drill press head is lowered on the column for crating and transportation. Before operating drill press, head must be raised to operational level, as follows.

1. Cut a 2x4 approximately 16-inches in length.

2. Loosen head locking nut (A, Figure 5-1) by turning counterclockwise with provided socket wrench.
3. Grasp head and turn it slightly from side to side to loosen the rust prevention solution on column.
4. Loosen table lock by placing handle on crankshaft (see A, Figure 8-1) and rotating handle counterclockwise.
5. Raise table by placing handle on crankshaft (B or C, Figure 8-1) and rotating clockwise. Place 2x4 vertically between table and head, as close to column as possible. CAUTION: Do not place 2x4 under lock collar (B, Figure 5-1).
6. Continue raising head and 2x4 until head bore and column are flush. Use a ladder to observe column through top of pulley cover.

⚠WARNING Do not raise head any farther or it may fall from column. Failure to comply may result in serious injury.

7. Securely tighten head locking nut (A, Figure 5-1). This will secure head until lock collar can be positioned. The 2x4 can now be safely removed.
8. Loosen two set screws on lock collar (B), and slide lock collar until it is flush with head. Securely tighten both set screws.

⚠WARNING Never loosen head locking nut (A) without supporting the head.

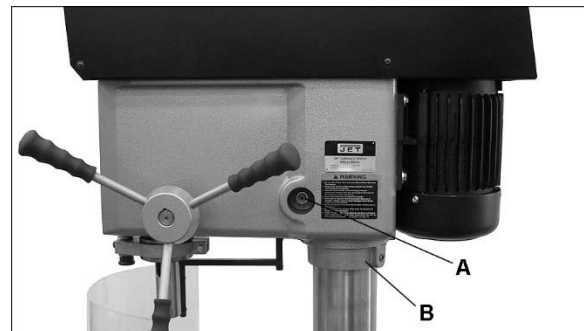

Figure 5-1

6.0 Electrical Connections

⚠WARNING Electrical connections must be made by a qualified electrician in compliance with all relevant codes. This machine must be properly grounded to help prevent electrical shock and possible fatal injury.

The **JDP-20VS-1** is pre-wired for single-phase, 115-volt. The machine can also be run on 230V power. See *sect. 6.3*.

The **JDP-20VS-3** is pre-wired for 3-phase, 230-volt. The machine can also be run on 460V power. See *sect. 6.3*.

The **JDP-20VST** is prewired for 3-phase, 230-volt only.

The drill press is not provided with an electrical plug; you may either attach a proper UL/CSA-listed plug, or “hardwire” the machine directly to a service panel.

6.1 GROUNDING INSTRUCTIONS

This tool must be grounded. In the event of a malfunction or breakdown, grounding provides a path of least resistance for electric current to reduce the risk of electric shock. This tool is equipped with an electric cord having an equipment-grounding conductor. If an electrical plug is to be used, the plug must be inserted into an appropriate outlet that is properly installed and grounded in accordance with all local codes and ordinances.

⚠WARNING Improper connection of the equipment-grounding conductor can result in a risk of electric shock. Check with a qualified electrician or service person if you are in doubt as to whether the outlet is properly grounded.

The conductor with insulation having an outer surface that is green with or without yellow stripes is the equipment-grounding conductor. If repair or replacement of the electric cord or plug is necessary, do not connect the equipment-grounding conductor to a live terminal.

Repair or replace damaged or worn cord immediately.

If hardwired:

Permanently connected tools: This tool should be connected to a grounded metal permanent wiring system; or to a system having an equipment-grounding conductor. Make sure a disconnect is available for the operator. During hard-wiring of the machine, make sure the fuses have been removed or the breakers have been tripped in the circuit to which the drill press will be connected. ALWAYS FOLLOW PROPER LOCK-OUT/TAG-OUT PROCEDURES.

6.2 Electrical cabinet access (JDP-20VST only)

To open electrical cabinet, press latch button and rotate latch to the left. A set of keys is provided for locking the cabinet door.

6.3 Voltage conversion (JDP-20VS-1/3 only)

1. Reconnect leads in motor junction box, according to diagram inside junction box cover. Diagrams are also found at back of this manual. (If discrepancies should occur, diagrams on machine take precedence.)
2. Remove pulley cover and reconnect wire on LED display accordingly (see Figure 6-3).
3. If using a plug, connect a proper UL-listed plug for the incoming voltage.

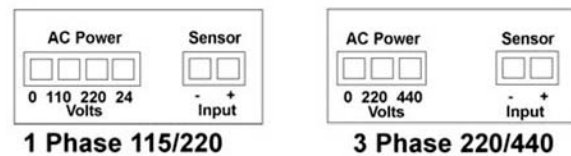

Figure 6-3: LED display connection

Make sure incoming current matches power requirements of the drill. When machine is connected properly, spindle turns clockwise in a conventional drilling rotation. If spindle does not turn clockwise on the 3-phase drill press when switch is set to forward rotation, disconnect machine from power supply and reverse any two of the three power leads (not the green ground wire).

Note: The work light has a dedicated power cable and continues to operate on 110V.

6.4 Extension cords

The use of extension cords is discouraged; try to position equipment within reach of the power source. If an extension cord becomes necessary, be sure it is heavy enough to carry the current your product will draw. An undersized cord will cause a drop in line voltage resulting in loss of power and overheating. Table 2 shows recommended size to use depending on cord length and nameplate ampere rating. If in doubt, use the next heavier gauge. The smaller the gauge number, the heavier the cord.

Ampere Rating		Volts	Total length of cord in feet			
More Than	Not More Than		25	50	100	150
		120	25	50	100	150
		240	50	100	200	300
AWG						
0	6		18	16	16	14
6	10		18	16	14	12
10	12		16	16	14	12
12	16		14	12	Not Recommended	

Table 2: extension cord recommendations

7.0 Operating controls

7.1 JDP-20VS-1/3 controls

Refer to Figure 7-1.

LED Display (A): Shows spindle RPM selected by speed control handwheel.

On/Fwd/Rev switch (B): Turns on spindle and selects rotation direction.

Speed control handwheel (C): Turn counter-clockwise to increase spindle speed.

CAUTION Move handwheel only while spindle is rotating. Failure to comply may cause damage to speed mechanism.

Downfeed handle (D): Raises and lowers quill.

Depth stop (E): Can be set for depths up to 6-inches.

Adjustment knob (E₁): Sets depth stop position.

Lock knob (E₂): Locks setting of depth stop.

Work light (F): Has separate on/off switch atop shade; flexible positioning.

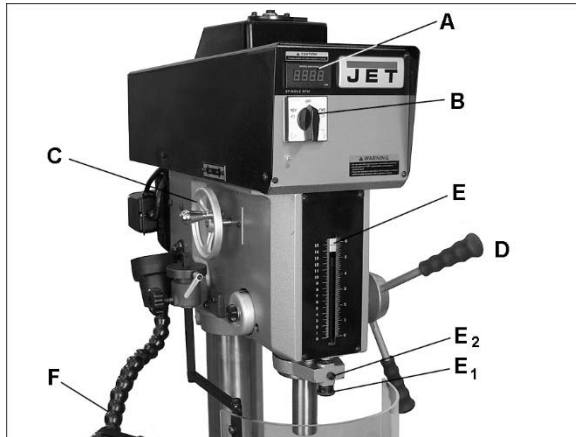

Figure 7-1: JDP-20VS-1/3 controls

7.2 JDP-20VST controls

Refer to Figure 7-2.

LED Display (A): Shows spindle RPM selected by speed control handwheel.

Speed control handwheel (C): Turn counter-clockwise to increase spindle speed.

CAUTION Move handwheel only while spindle is rotating. Failure to comply may cause damage to speed mechanism.

Downfeed handle (D): Raises and lowers quill.

Depth stop (E): Can be set for depths up to 6-inches. Activates limit switches in tapping mode.

Adjustment knob (E₁): Sets depth stop position.

Lock knob (E₂): Locks setting of depth stop.

Work light (F): Has separate on/off switch atop shade; flexible positioning.

Speed range switch (G): Two ranges. Middle position is neutral – spindle off. Must be set to high or low before front panel controls will function.

Drill mode switch (H): Selects drill or tap mode. Middle position is neutral – spindle will not move.

Spindle on button (I): Starts spindle rotation.

Spindle off button (J): Stops spindle rotation. (Other functions such as coolant pump will continue to operate.)

E-Stop (K): Emergency stop button shuts down all drill press functions. To restart drill press, turn E-stop button clockwise until it disengages.

Coolant pump switch (L): (Optional accessory); starts and stops coolant pump circulation.

Reverse spindle (M): If tapping is interrupted, press and hold this button to reverse tap from workpiece. When button is released, spindle will resume forward rotation.

Power on light (N): Indicates electrical current is flowing to machine.

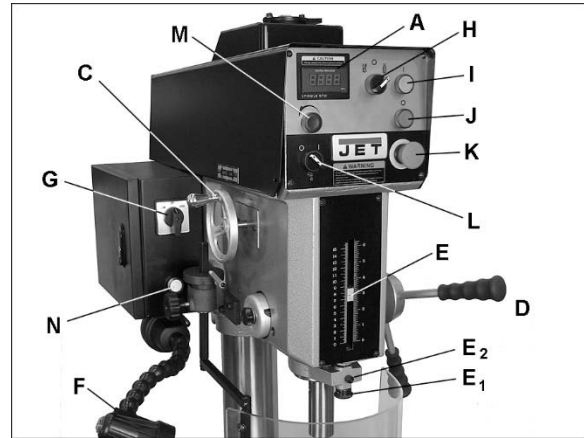

Figure 7-2: JDP-20VST controls

8.0 Adjustments

8.1 Depth stop

The drilling depth indicator (E, Figures 7-1 and 7-2) can be set for depths up to 6 inches (152.4 mm).

8.1.1 For drilling (all models)

1. (Set switch to drill mode (H) on JDP-20VST.)
2. Before starting motor, use downfeed handle to set end of drill against surface into which hole is to be drilled.

3. Set depth block to zero by turning knurled knob (E₁). Then adjust block to desired depth of hole, and secure setting with knob (E₂).
4. Start motor and drill hole until travel is restrained by indicator block.

8.1.2 For tapping (JDP-20VST only)

1. Set depth stop in same manner as above.
2. Set tapping mode (H).
3. When quill is advanced using downfeed handle (D), upper limit switch will be released for tapping. When lower limit switch is triggered, spindle will reverse rotation direction. When spindle is returned to highest position, it will resume forward rotation.

NOTE: When tapping mode is off, limit switches are deactivated and do not affect spindle rotation.

8.2 Table adjustment

The table can be raised or lowered to accommodate workpiece height. Place hand crank on shaft (A, Figure 8-1) and turn counterclockwise to loosen table lock. Then use hand crank on shaft B or C to raise or lower table. Lock table in position using shaft A.

If drill press base is to be used for securing workpiece, loosen table (A) and swing it around column and out of the way. Retighten table.

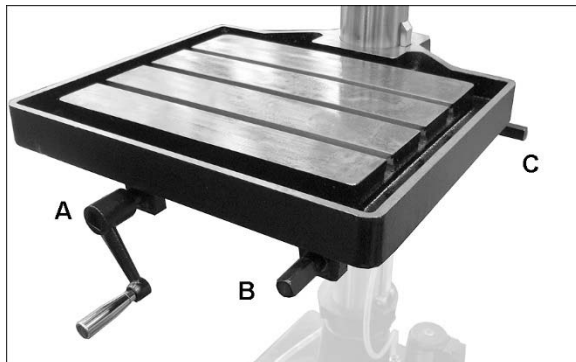

Figure 8-1: table adjustments

8.3 Tool installation and removal

1. Disconnect machine from power source.
2. Thoroughly clean inside of spindle with a soft dry cloth. Also clean any taper or arbor to be used in the spindle. If these are not kept clean, taper or arbor will not “seat” properly in spindle and may drop out unexpectedly.
3. Place protective piece of scrap wood on table.
4. Raise table to approximately 8-to-10 inches below spindle.
5. Insert MT-4 tool into spindle.
6. Lower spindle using downfeed handle, and seat tool against the wood.

7. If installing a drill chuck, retract the jaws then use rubber mallet (or steel face hammer against a block of wood) to sharply tap bottom of chuck two or three times to seat it. NOTE: Never use a steel face hammer directly against the chuck.

To remove a tool:

1. Disconnect machine from power source.
2. Lower spindle to expose slots in spindle wall.
3. Insert drift key into spindle slots and tap gently until drill bit or chuck arbor loosens. Hold tool with one hand (use glove or rag if needed) while tapping to prevent tool from falling and being damaged.

8.4 Speed pickup adjustment

Speed pickup has been set correctly by the manufacturer. If the speed readout display should lose accuracy, adjustment can be made as follows. Refer to index numbers on exploded view, sect. 13.3.1.

1. Loosen screws securing speed pickup (ref. #50) to plate (#51).
2. Adjust speed pickup gap to approximately 1/8-inch. Retighten screws.
3. Operate drill press to verify that speed readout is operating correctly.

8.5 Spindle return spring adjustment

The spindle return is preset by the manufacturer and should not need adjustment. If future attention is ever required, proceed as follows:

1. Do NOT remove spring cap (D, Figure 8-2).
2. Loosen knob (E) just enough to rotate spring cap past notch (F).
3. Rotate spring cap clockwise to decrease spring tension. Rotate spring cap counter-clockwise to increase spring tension.
4. Re-tighten knob (E).

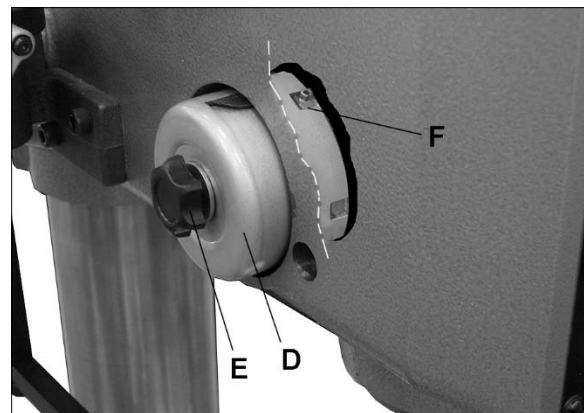

Figure 8-2: return spring adjustment

8.6 Coolant pump (optional)

The coolant system (not provided) should be filled with 2 gallons of a cutting coolant. Fill by pouring coolant into base of machine. Add coolant in the same manner when coolant is low. To drain coolant, remove hex cap screw located on lower backside of base. Follow all coolant manufacturer's instructions for safety, mixing and disposal.

Make sure drain hose has good, tight connection into table and that coolant flows into base.

Make sure hose leaving pump and entering ball valve has good, tight connections.

The flexible nozzle enables user to adjust coolant for each job. One ball valve controls coolant flow to nozzle.

9.0 Operation

9.1 Operating precautions

The following operating and safety precautions must be observed in order to avoid harm to operator or damage to drill press.

1. Head assembly must be locked to column so the thrust produced by drilling will not force the head assembly up the column.
2. Work table must be locked to column so it will not be forced down the column.
3. Belts should be properly tensioned.
4. Do NOT start to drill workpiece until making certain workpiece is held down securely.
5. **Make sure drive motor is running BEFORE** turning speed control handwheel in either direction.
6. Point of operation protection is required for maximum safety. This remains the responsibility of the user/purchaser since conditions differ between jobs.
7. Make sure tool is secured in the spindle or chuck before attempting to use the drill press.
8. Make sure spindle taper is clean and free of burrs, scoring, and galling to assure maximum gripping.
9. Lock quill in position when using any side-loaded tool.

9.2 Drilling recommendations

9.2.1 Drilling speeds

The speed of a drill is usually measured in terms of the rate at which the outer periphery of the tool moves in relation to the work being drilled. The common term for this is Surface Feet per Minute (SFM). The relationship of SFM is expressed in the following formulas:

$$\text{SFM} = 0.26 \times \text{RPM} \times \text{Drill Diameter (in inches)}$$

$$\text{RPM} = 3.8 \times \frac{\text{SFM}}{\text{Drill diameter (in inches)}}$$

In general, the higher the speed the shorter the drill life. Operating at the low end of the speed range for a particular material will result in longer life. The most efficient speed for drill operation depends upon many variables:

1. Composition and hardness of material.
2. Depth of hole.
3. Efficiency of cutting fluid.
4. Type and condition of drilling machine.
5. Desired quality of hole.
6. Difficulty of set-up.

9.2.2 Drilling feed

The feed of a drill is governed by size of tool and the material drilled. Because feed rate partially determines rate of production and also is a factor in tool life, it should be chosen carefully for each job. In general, the most effective feeds will be found in the following ranges:

Diameter of Drill (inches)	Feed per Revolution (inches)
Under 1/8	0.001 to 0.002
1/8 to 1/4	0.002 to 0.004
1/4 to 1/2	0.004 to 0.007
1/2 to 5/8	0.007 to 0.015

Table 3

9.2.3 Speeds for high speed steel drills

Material	Speed (SFPM)
Alloy Steel — 300 to 400 Brinell	20-30
Stainless Steel	30-40
Automotive Steel Forgings	40-50
Tool Steel, 1.2C	50-60
Steel, .4C to .5C	70-80
Mild Machinery Steel, .2C to .3C	80-110
Hard Chilled Cast Iron	30-40
Medium Hard Cast Iron	70-100
Soft Cast Iron	100-150
Malleable Iron	80-90
High Nickel Steel or Monel	40-50
High Tensile Bronze	70-150
Ordinary Brass and Bronze	200-300
Aluminum and its Alloys	200-300
Magnesium and its Alloys	250-400
Slate, Marble, and Stone	15-25
Plastics and similar materials (Bakelite)	100-150
Wood	300-400
Titanium Alloys	10-25
Titanium Alloy Sheet	50-60

Note: In cases where carbon steel drills are applicable, the drill should be run at speeds of 40 to 50 percent of those given above.

Table 4

9.2.4 Excessive speed/feed indicators

A drill that splits up the web is evidence of too much feed or insufficient tip clearance at the center as a result of improper grinding. The rapid wearing away of the extreme outer corners of cutting edges indicates that speed is too high. A drill chipping or breaking out at the cutting edges indicates that either feed is too heavy or drill has been ground with too much tip clearance.

10.0 User-maintenance

10.1 Drive belt replacement

⚠WARNING Disconnect electrical power to drill press to avoid possibility of inadvertent operation and exposure to potentially lethal voltage levels.

1. Start drill press. Set speed control to highest speed. Stop drill press.
2. Disconnect machine from power source.
3. Remove pulley cover.
4. Remove belt. (With speed control setting at highest speed, belt should be loose enough to remove.)
5. Install replacement belt. Install pulley cover.
6. Connect drill press to power and run machine to verify correct operation.

10.2 Motor replacement

⚠WARNING Disconnect electrical power to drill press to avoid possibility of inadvertent operation and exposure to potentially lethal voltage levels.

1. Remove drive belt (sect. 10.1).
2. Disconnect electrical wiring from motor junction box.
3. Remove nuts from mounting studs securing motor to drill head. Remove motor.
4. Remove upper and lower pulleys and related components from motor shaft.
5. Install upper and lower pulleys and related components on replacement motor shaft.
6. Install motor on mounting studs and secure with nuts.
7. Connect electrical wiring (refer to wiring diagram for details).
8. Install drive belt (sect. 10.1).
9. Connect drill press to power and run machine to verify correct operation.

10.3 Lubrication

See Table 4 for lubrication points and recommended frequency. Avoid getting oil or grease on belts.

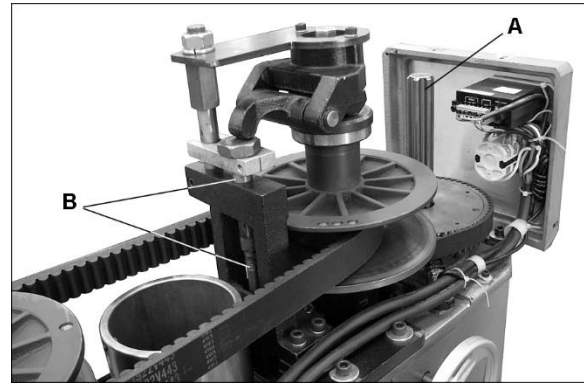

Figure 10-1

Lubrication points		
Location	Recommended lubricant	Frequency
Spindle splines (A, Figure 10-1)	#2 lithium based tube grease	Monthly
Quill and column	Machine tool oil	Daily
Table raising rack	SAE 20 oil (clean rack with kerosene before oiling)	Weekly
Push rods (B, Figure 10-1)	#2 lithium based tube grease	Periodically as needed

Table 4

10.4 Additional servicing

Any additional servicing should be performed by authorized service personnel.

11.0 Coolant system (optional)

Coolant pump system is optional. Contact your JET dealer for more information. See *sect. 13.5.2* for stock number to order, depending upon your model of drill press. (Note: The following illustrations may or may not show your particular drill press.)

11.1 Coolant system installation

1. Remove large reservoir cover from machine base. Tap 1/4-20 threads in the 4 pilot holes. (Holes may already be threaded in some models.)
2. Install large cover plate back onto machine base.
3. Insert pump into opening, utilize the screws from the small round cover plate to fasten pump to base.
4. Position power switch and valve bracket in convenient position on spindle casting. Mark mounting hole locations and drill holes. (Refer to Figure 11-1)

Note: Mount components near the lower edge of the spindle casting. DO NOT mount components above the line shown in Figure 11-1.

5. Install power switch and valve bracket with the provided fasteners.
- Note:** On the JDP-20VST, coolant operation can be wired to the switch on the front panel.
6. Install the 3/8-inch hose coupling to the coolant pump. If needed, apply light coat of pipe sealant or thread seal tape to threads to prevent leakage.
 7. Mount flow valve to bracket, connect supply hose to pump and valve, and use hose clamps at the ends.
 8. Install flexible nozzle to flow valve.
 9. Install 1/2-inch hose coupler to worktable, and seal threads if needed. Connect return hose.
 10. Connect power cord to a suitable source and ground (refer to *General electrical cautions*).
 11. Fill reservoir with appropriate machining coolant. Capacity = approximately 2 gal.

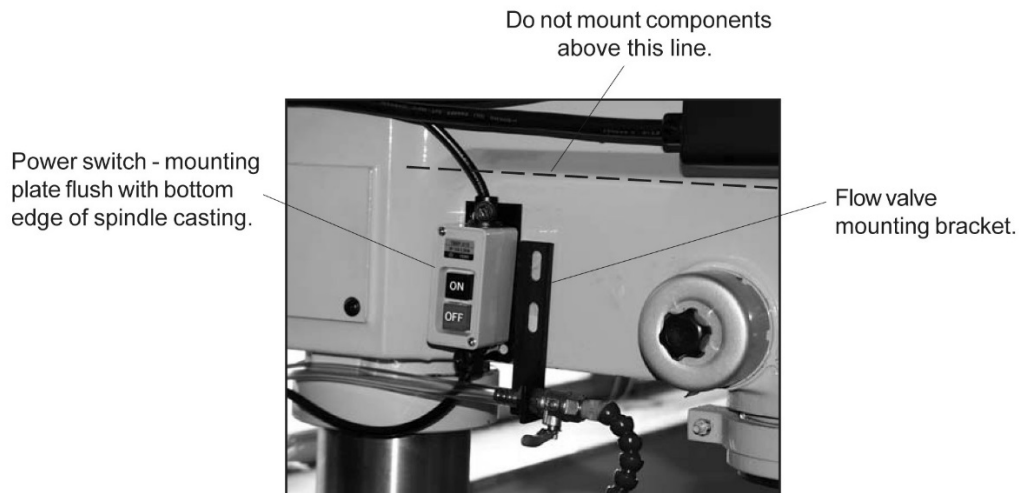

Figure 11-1

12.0 Troubleshooting JDP-20VS series Drill Press

Trouble	Probable Cause	Remedy *
Spindle does not turn.	Overload protector tripped.	Allow machine to cool, then press reset button on overload relay.
	Branch circuit breaker tripped or fuse blown.	Reset branch circuit breaker/replace fuse. Make sure incoming power matches machine specs.
	Open wire in switch circuit.	Repair open circuit.
	Defective switch.	Replace switch.
	Broken drive belt.	Replace drive belt.
Spindle noisy.	Damaged spindle bearings.	Replace bearings.
	Worn spline.	Replace spline.
	Insufficient lubrication.	Maintain proper lubrication.
Drill stalls.	Worn drive belt.	Check condition of belt. Replace if glazed or slipping on pulleys.
	Excessive feed rate for size of drill and material being drilled. No cutting fluid or improper cutting fluid.	Reduce feed pressure or use cutting fluid. Use correct cutting fluid.
Poorly drilled holes.	Dull drill.	Sharpen or replace drill.
	Lack of rigidity in hold-down method.	Check that all T-slot hold-downs are tight and that table-lock and drill head bolts are tight.
	Speed too fast for material and drill size.	Check spindle speed recommendations. Reduce speed if necessary.
	Feed too fast for material and drill size.	Reduce feed rate.
	No or improper cutting fluid or coolant being used.	Use cutting fluid, or change to proper fluid or coolant for material being drilled.
	Improperly ground drill bit.	Check for proper angles and reliefs. Regrind to proper geometry.
Motor overheating.	Electrical circuit fault.	Check current draw in circuit. Make sure current draw is the same as rating on motor plate.
	Oversize drill.	Reduce drill size.
	Excessive feed.	Reduce feed rate.
	No cutting fluid, or wrong fluid.	Use correct cutting fluid for the material and drill.
Table binding, or cannot be raised.	Lack of lubrication.	Clean and lubricate rack, column, shafts, or wherever needed.
No speed readout.	Speed pickup out of adjustment or failed.	Adjust gap between speed pickup and post spindle pulley. If there is no readout on the LED speed indicator after adjusting the gap, replace the speed pickup.

***WARNING:** Some corrections may require a qualified electrician.

Table 5

13.0 Replacement Parts

Replacement parts are listed on the following pages. To order parts or reach our service department, call 1-800-274-6848, Monday through Friday, 8:00 a.m. to 5:00 p.m. CST. Having the Model Number and Serial Number of your machine available when you call will allow us to serve you quickly and accurately.

Non-proprietary parts, such as fasteners, can be found at local hardware stores, or may be ordered from JET. Some parts are shown for reference only, and may not be available individually.

13.1.1 Drill Head – Manual Speed Control (JDP-20VS-1/3) – Exploded View

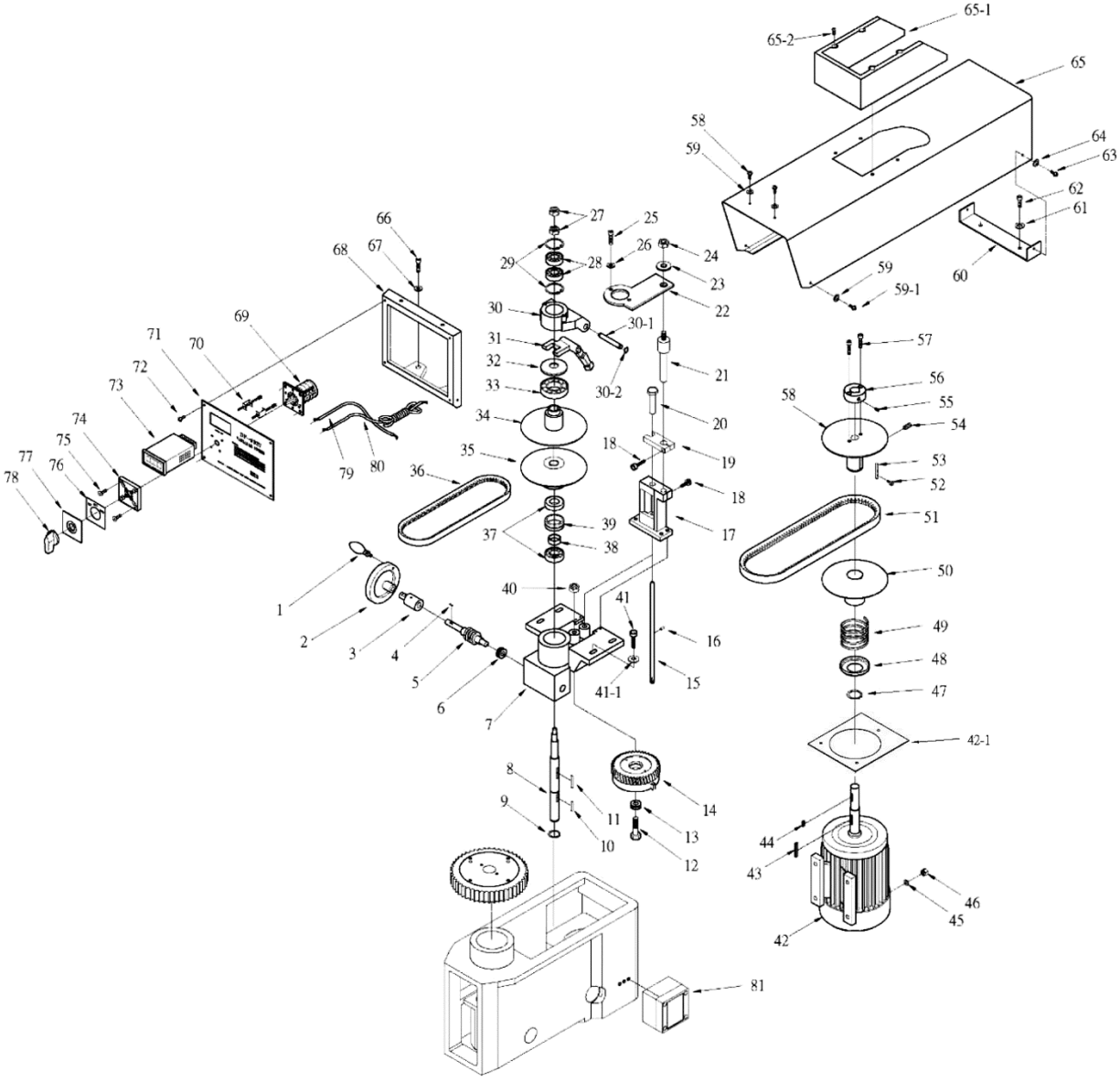

13.1.2 Drill Head – Manual Speed Control (JDP-20VS-1/3) – Parts List

Index No.	Part No.	Description	Size	Qty
1	5510126	Hand Grip		1
2	5510126	Handwheel (includes #1)		1
3	JDP20VS-TH03	Bushing		1
4	JDP20VS-TH04	Key	4x4x15 mm	1
5	JDP20VS-TH05	Worm Shaft		1
6	BB-51101ZZ	Thrust Bearing	51101zz	1
7	JDP20VS-TH07	Bearing Housing		1
8	JDP20VS-TH08	Spindle Mid Shaft		1
9	5519933	C-Ring, External (shaft)	S-25	1
10	6293358	Key, Double Rd Head	5x5x25 mm	1
11	5784011	Key, Double Rd Head	5x5x40 mm	1
12	JDP20VS-TH12	Shaft		1
13	BB-51101ZZ	Thrust Bearing	51101zz	1
14	JDP20VS-TH14	Worm Shaft		1
15	JDP20VS-TH15	Control Rod		1
16	6286786	Roll Pin	4x15 mm	1
17	JDP20VS-TH17	Housing		1
18	TS-1503051	Hex Socket Cap Screw	M6x20	1
19	JDP20VS-TH19	Bracket		1
20	JDP20VS-TH20	Control Rod Sleeve		1
21	JDP20VS-TH21	Shaft		1
22	JDP20VS-TH22	Plate		1
23	TS-0720131	Spring Washer	5/8"	1
24	TS-0640132	Hex Nut	5/8"-18UNF	1
25	TS-1504041	Hex Socket Cap Screw	M8x20	2
26	TS-0680031	Washer	5/16"	2
27	9056311	Hex Nut	7/16"-20UNF	2
28	BB-6302ZZ	Ball Bearing	6302zz	2
29	F006077	C-Ring, Internal (Hole)	R-42	1
30	JDP20VS-TH30	Speed Change Bracket		1
30-1	JDP20VS-TH30-1	Support Rod		1
30-2	6286478	C-Ring, External (Shaft)	S-12	2
31	JDP20VS-TH31	Speed Change Lever		1
32	JDP20VS-TH32	Bearing Cover		1
33	BB-6207ZZ	Ball Bearing	6207zz	1
34	JDP20VS-TH34	Upper Spindle Pulley		1
35	JDP20VS-TH35	Lower Spindle Pulley		1
36	8M640	Belt	8Mx640	1
37	BB-6205ZZ	Ball Bearing	6205zz	2
38	JDP20VS-TH38	Bushing		1
39	JDP20VS-TH39	Bushing		1
40	TS-0561052	Hex Nut	1/2"-20UNF	1
41	TS-1504071	Hex Socket Cap Screw	M8x35	4
41-1	TS-0680031	Washer	5/16"	4
42	JDP20VS-TH42/1	Motor	4P/1Ph	1
	JDP20VS-TH42/2	Motor	4P/3Ph	1
42-1	JDP20VS-TH42-1	Plate		1
43	S0400545	Key, Double Rd Head	5x5x45 mm	1
44	5510675	Key, Double Rd Head	5x5x20 mm	1
45	TS-0680031	Washer	5/16"	4
46	JDP20VS-TH46	Hex+C26. Screw	M8x25	4
47	JDP20VS-TH47	C-Ring (Shaft)	S-45	1
48	JDP20VS-TH48	Spring Cover		1
49	JDP20VS-TH49	Spring		1
50	JDP20VS-TH50	Lower Motor Pulley		1
51	JDP20VS-TH51	Belt	1922V443	1
52	TS-1532032	Pan Head Screw	M4x10	4
53	JDP20VS-TH53	Key		2
54	TS-1522021	Set Screw	M5x8	1
55	TS-1524011	Set Screw	M8x8	2
56	JDP20VS-TH56	Bushing		1
57	TS-1503051	Hex Socket Cap Screw	M6x20	2
58	JDP20VS-TH58	Upper Motor Pulley		1

Index No.	Part No.	Description	Size	Qty
59	TS-0680021	Washer	1/4"	4
59-1	F009885	Button Head Socket Screw	M5x10	4
60	JDP20VS-TH60	Plate Bracket		1
61	TS-0680031	Washer	5/16"	2
62	TS-1504041	Hex Socket Cap Screw	M8x20	2
63	F000299	Phillips Pan Hd Machine Screw	1/4"x1/2"	2
64	TS-0680021	Washer	1/4"	2
65	JDP20VS-TH65	Pulley Cover		1
65-1	JDP20VS-TH65-1	Top Cover		1
65-2	F009669	Hex Socket Button Screw	#10-24UNCx3/8"	4
66	TS-1504061	Hex Socket Cap Screw	M8x30	2
67	TS-0680031	Washer	5/16"	2
68	JDP20VS-TH68	Plate Bracket		1
69	5517323	Fwd/Rev Switch Assembly 1PH (includes # 74~78)		1
	5517331	Fwd/Rev Switch Assembly 3PH (includes # 74~78)		1
70	JDP20VS-TH70	Cap Screw		2
71	JDP20VS-TH71	Face Plate		1
72	TS-1533032	Phillips Pan Hd Machine Screw	M5x10	4
73	5513519	LED Display for 1ph	115/230/24V	1
	5513736	LED Display for 3ph	220/440	1
74	JDP20VS-TH74	Switch Plate		1
75	TS-1532052	Phillips Pan Hd Machine Screw	M4x16	2
76	JDP20VS-TH76	Label Fwd/Rev		1
77	JDP20VS-TH77	Label Cover		1
78	JDP20VS-TH78	Knob		1
79	JDP20VS-TH79	Connection Cord		1
80	JDP20VS-TH80	Power Cord	.12AWG x3C 600V 105°C	1
81	JDP20VS-TH81	Power Cable Terminal Box		1
	JDP20VS-WL	Work Light (not shown)	input 110V	1
	LM000265	ID/Warning Label, JDP-20VS-1 (not shown)		1
	LM000266	ID/Warning Label, JDP-20VS-3 (not shown)		1
	JET-113	JET Logo (not shown)	113x47mm	1

13.2.1 Drill Head – Two Speed Control (JDP20VST) – Exploded View

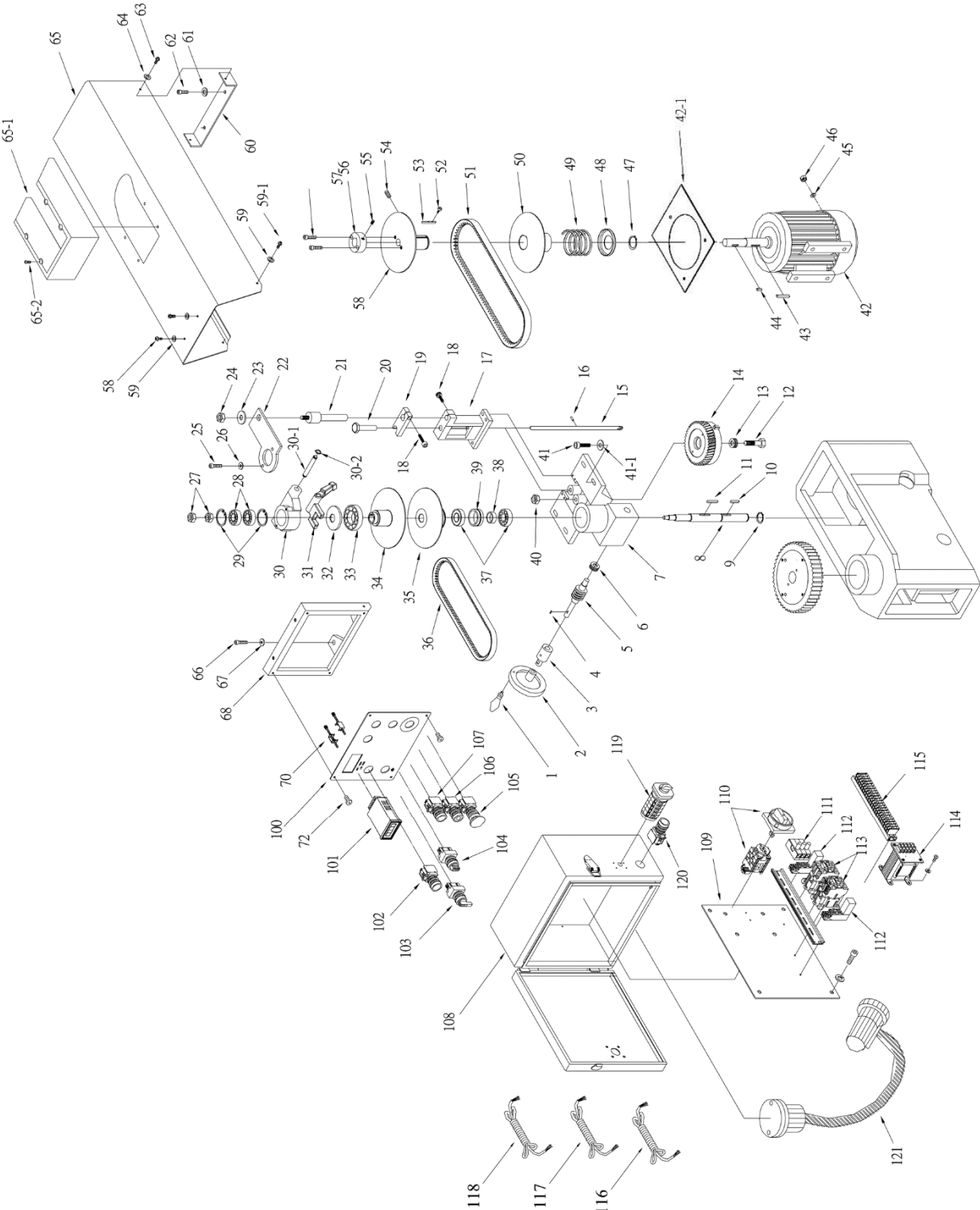

13.2.2 Drill Head – Two Speed Control (JDP20VST) – Parts List

Index No.	Part No.	Description	Size	Qty
1	5510126	Hand Grip		1
2	5510126	Handwheel (includes #1)		1
3	JDP20VS-TH03	Bushing		1
4	JDP20VS-TH04	Key	4x4x15	1
5	JDP20VS-TH05	Worm Shaft		1
6	BB-51101ZZ	Thrust Bearing	51101zz	1
7	JDP20VS-TH07	Bearing Housing		1
8	JDP20VS-TH08	Spindle Mid Shaft		1
9	5519933	C-Ring, External (shaft)	S-25	1
10	6293358	Key, Double Rd Head	5x5x25 mm	1
11	5784011	Key, Double Rd Head	5x5x40 mm	1
12	JDP20VS-TH12	Shaft		1
13	BB-51101ZZ	Thrust Bearing	51101ZZ	1
14	JDP20VS-TH14	Worm Shaft		1
15	JDP20VS-TH15	Push Rod		1
16	6286786	Roll Pin	4x15 mm	1
17	JDP20VS-TH17	Housing		1
18	TS-1503051	Hex Socket Cap Screw	M6x20	1
19	JDP20VS-TH19	Bracket		1
20	JDP20VS-TH20	Control Rod Sleeve		1
21	JDP20VS-TH21	Shaft		1
22	JDP20VS-TH22	Plate		1
23	TS-0720131	Spring Washer	5/8"	1
24	TS-0640132	Hex Nut	5/8"-18UNF	1
25	TS-1504041	Hex Socket Cap Screw	M8x20	2
26	TS-0680031	Washer	5/16"	2
27	9056311	Hex Nut	7/16"-20UNF	2
28	BB-6302ZZ	Ball Bearing	6302zz	2
29	F006077	C-Ring, Internal (Hole)	R-42	1
30	JDP20VS-TH30	Speed Change Bracket		1
30-1	JDP20VS-TH30-1	Support Rod		1
30-2	6286478	C-Ring, External (Shaft)	S-12	2
31	JDP20VS-TH31	Speed Change Lever		1
32	JDP20VS-TH32	Bearing Cover		1
33	BB-6207ZZ	Ball Bearing	6207ZZ	1
34	JDP20VS-TH34	Upper Spindle Pulley		1
35	JDP20VS-TH35	Lower Spindle Pulley		1
36	8M640	Belt	8Mx640	1
37	BB-6205ZZ	Ball Bearing	6205zz	2
38	JDP20VS-TH38	Bushing		1
39	JDP20VS-TH39	Bushing		1
40	TS-0561052	Hex Nut	1/2"-20UNF	1
41	TS-1504071	Hex Socket Cap Screw	M8x35	4
41-1	TS-0680031	Washer	5/16"	4
42	JDP20VST-TH42	Motor	4/8P /3Ph	1
42-1	JDP20VS-TH42-1	Plate		1
43	S0400545	Key, Double Rd Head	5x5x45 mm	1
44	5510675	Key, Double Rd Head	5x5x20 mm	1
45	TS-0680031	Washer	5/16"	4
46	JDP20VS-TH46	Hex+C26. Screw	M8x25	4
47	JDP20VS-TH47	C-Ring (Shaft)	S-45	1
48	JDP20VS-TH48	Spring Cover		1
49	JDP20VS-TH49	Spring		1
50	JDP20VS-TH50	Lower Motor Pulley		1
51	JDP20VS-TH51	Belt	1922V443	1
52	TS-1532032	Pan Head Screw	M4x10	4
53	JDP20VS-TH53	Key		2
54	TS-1522021	Set Screw	M5x8	1
55	TS-1524011	Set Screw	M8x8	2
56	JDP20VS-TH56	Bushing		1
57	TS-1503051	Hex Socket Cap Screw	M6x20	2
58	JDP20VS-TH58	Upper Motor Pulley		1
59	TS-0680021	Washer	1/4"	4

Index No.	Part No.	Description	Size	Qty
59-1	F009885	Button Head Socket Screw	M5x10	4
60	JDP20VS-TH60	Plate Bracket		1
61	TS-0680031	Washer	5/16"	2
62	TS-1504041	Hex Socket Cap Screw	M8x20	2
63	F000299	Phillips Pan Hd Machine Screw	1/4"x1/2"	2
64	TS-0680021	Washer	1/4"	2
65	JDP20VS-TH65	Pulley Cover		1
65-1	JDP20VS-TH65-1	Top Cover		1
65-2	F009669	Hex Socket Button Screw	#10-24UNCx3/8"	4
66	TS-1504061	Hex Socket Cap Screw	M8x30	2
67	TS-0680031	Washer	5/16"	2
68	JDP20VS-TH68	Plate Bracket		1
70	JDP20VS-TH70	Cap Screw		2
72	TS-1533032	Phillips Pan Hd Machine Screw	M5x10	4
100	JDP20VST-TH100	Control Panel		1
101	5513736	LED Display	220/440	1
102	JDP20VST-TH102	Reversal Switch		1
103	JDP20VST-TH103	Pump Switch		1
104	JDP20VST-TH104	Selection Switch D/T		1
105	JDP20VST-TH105	Emergency Stop Switch		1
106	JDP20VST-TH106	Stop Switch		1
107	JDP20VST-TH107	Start Switch		1
108	JDP20VST-TH108	Electric Box		1
109	JDP20VST-TH109	Switch		1
110	JDP20VST-TH110	Safety Switch Assembly		1
111	JDP20VST-TH111	Fuse Block		1
111-1	JDP20VST-TH111-1	Fuse (not shown)	0.5A	2
111-2	JDP20VST-TH111-2	Fuse (not shown)	1A	3
112	JDP20VST-TH112	Relay		2
113	JDP20VST-TH113	Contact		2
113-1	JDP20VST-TH113-1	Overload Switch	NTH-8 6-8A set 7A	1
114	JDP20VST-TH114	Transformer	60VA, 0/230V-24V	1
115	JDP20VST-TH115	Terminal Plate		1
116	JDP20VST-TH116	Power Cable	14AWG x3C 600V 105°C	1
117	JDP20VST-TH117	Motor Cable	1.25mm x7C	1
118	JDP20VST-TH118	Pump Cable	3x 0.824mm ² (18AWG)	1
119	JDP20VST-TH119	4P/8P Switch		1
120	JDP20VST-H120	Power Indicator Light		1
121	JDP20VS-WL	Work Light	input 110V	1
	LM000267	ID/Warning Label, JDP-20VST (not shown)		1
	JET-92	JET Logo (not shown)	92x38mm	1

13.3.1 Spindle Components (All Models) – Exploded View

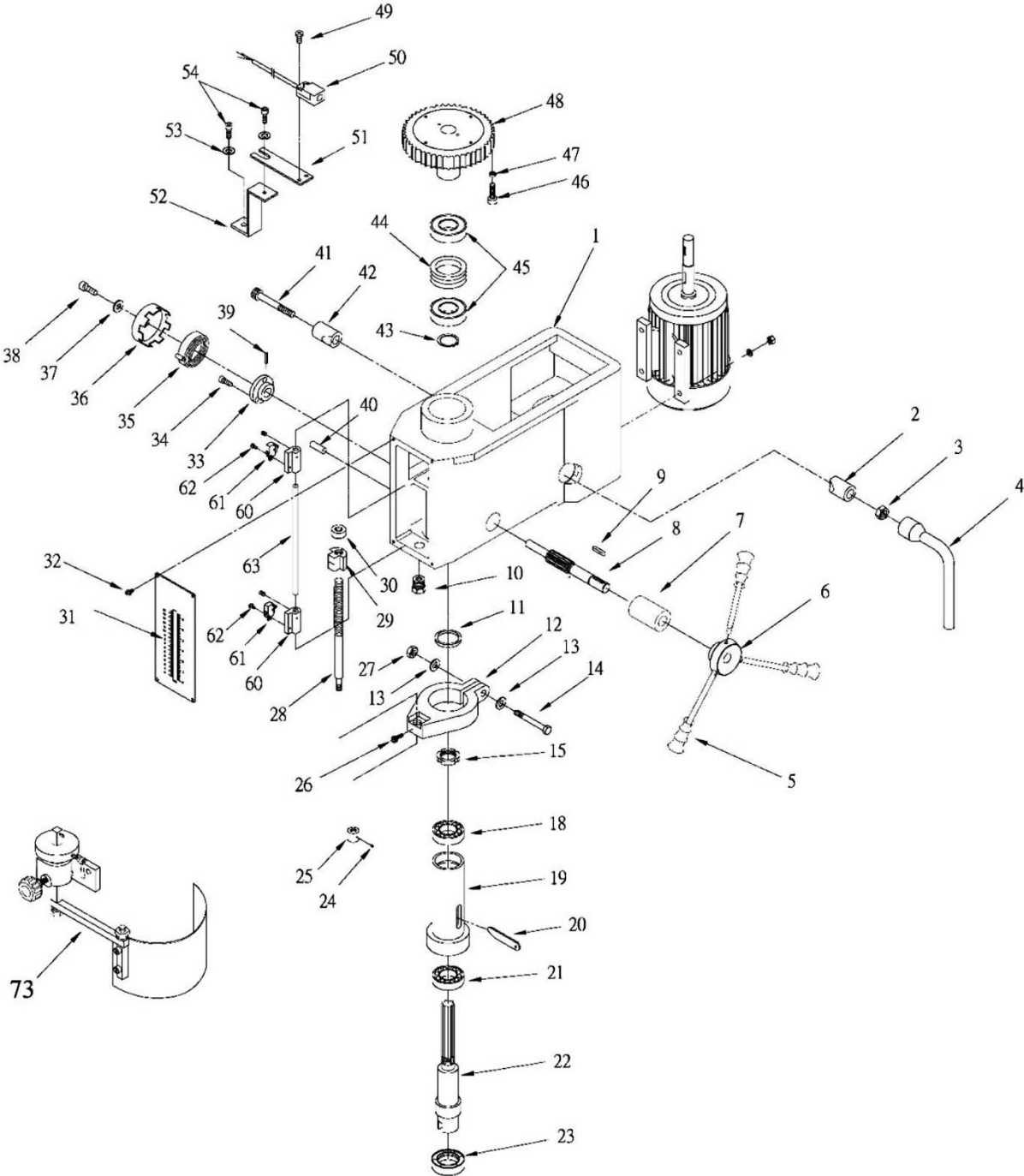

13.3.2 Spindle Components (All Models) – Parts List

Index No.	Part No.	Description	Size	Qty
1	J-5517332G	Head Casting		1
2	5510320	Rear Cam Lock		2
3	5510250	Hex Nut		1
4	5510251	Hex Head Wrench		1
5	5510286-RHA	Rubber Handle Assembly		3
6	J-5510285G	Hub		1
7	JDP20VS-LH07	Feed Shaft Seat		1
8	JDP20VS-LH08	Feed Shaft		1
9	5510282	Key	6x6x20	1
10	5510258	Set screw		1
11	5513770	Rubber Washer		1
12	J-5513771G	Quill Band		1
13	TS-0680021	Flat Washer	1/4"	2
14	5517380	Hex Screw	1/4"x2-1/2"	1
15	5510258	Lock Nut		1
18	BB-30206	Ball Bearing	30206	1
19	5510268	Quill		1
20	5513774	Drift Pin		1
21	BB-30207	Ball Bearing	30207	1
22	5510270	Spindle	MT3 / MT4	1
23	5510271	Oil Seal	45x72x8	1
24	TS-1523011	Set screw	M6	2
25	5510276	Retainer		1
26	JDP20VS-LH26	Set Screw	1/4"	1
27	TS-0561011	Hex Nut	1/4"	1
28	5510273	Depth Rod		1
29	JDP20VS-LH29	Depth Scale Bracket		1
30	5510272	Nut		1
31	5510278	Depth Scale		1
32	5510279	Screw	3/16"x5/16"	4
33	5510266	Spring Seat		1
34	5510265	Screw	3/16"x5/16"	3
35	5510263	Return Spring		1
36	5510263	Container (includes #35)		1
37	TS-0680021	Washer	1/4"	1
38	5510261	Set Knob	1/4"	1
39	5510267	Spring Pin		1
40	5510259	Roll Pin		1
41	JDP20VS-LH41	Hex. Shoulder Bolt		1
42	JDP20VS-LH42	Bushing		1
43	5510256	C-Ring	S45	1
44	5510255	Spacer		1
45	BB-6009ZZ	Ball Bearing	6009zz	2
46	F004766	Hex. Socket Cap Screw	#10-24x1"	1
47	TS-0560071	Hex Nut	#10-24	1
48	JDP20VS-LH48	Spindle Pulley	8Mx62T	1
49	TS-2244202	Screw	M4x20	1
50	5513515	Sensor		1
51	5517383	Sensor Support		1
52	JDP20VS-LH52	Sensor Bracket		1
53	TS-0680031	Washer	5/16"	2
54	TS-1504041	Hex. Socket Cap Screw	M8x20	2
60	JDP20VST-60	Micro switch bracket		2
61	JDP20VST-61	Micro Switch		2
62	JDP20VST-62	Screw	M3x16	4
63	JDP20VST-63	Micro Switch Support Rod		1
73	32106A	Safety Shield Assembly (for all models)		1

13.4.1 Safety Shield Assembly (All Models) – Exploded View

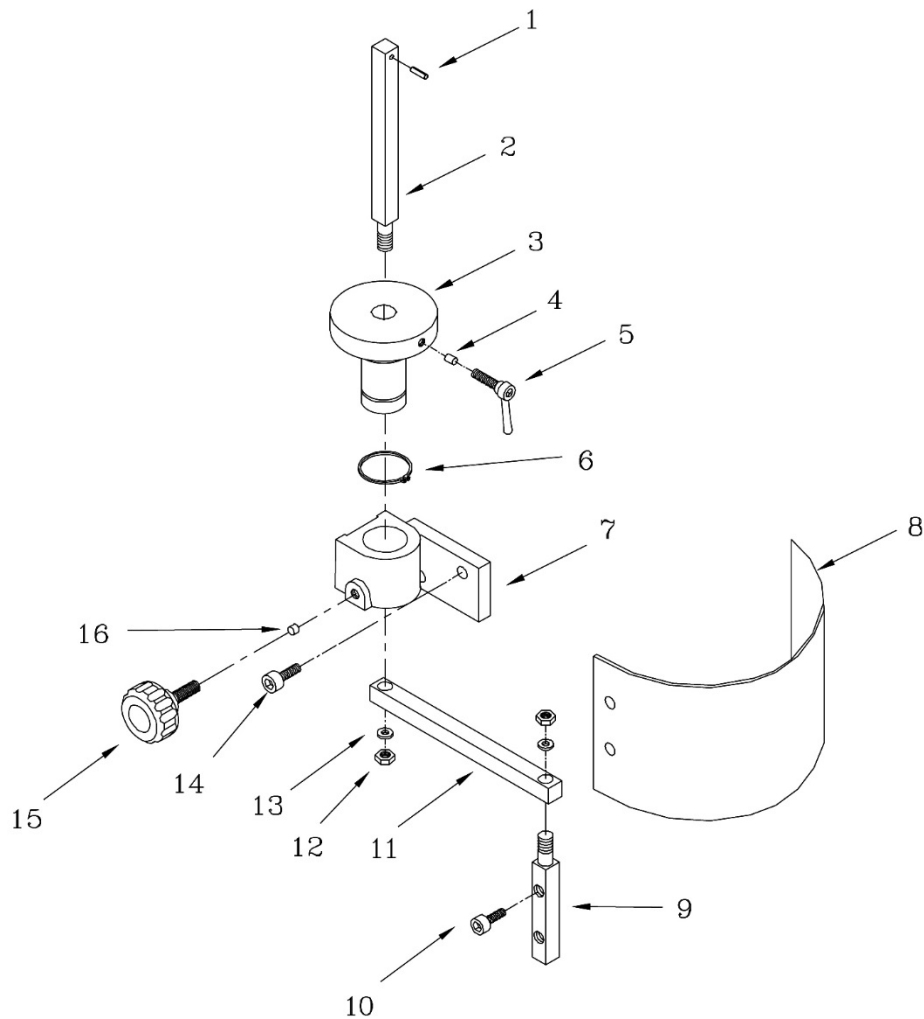

13.4.2 Safety Shield Assembly (All Models) – Parts List

Index No.	Part No.	Description	Size	Qty
.....	32106A.....	Safety Shield Assembly (#1 thru 16)	1
1	6293347	Spring Pin.....	3x16	1
2	32106A-2	Support Bracket Bar.....	1
3	32106A-3	Bushing	1
4	32106A-4	Spacer.....	1
5	32106A-5	Lock Handle	M6x20	1
6	32106A-6	C-Clip	S30.....	1
7	32106A-7	Bracket.....	1
8	32106A-8.....	Safety Shield	530x210mm	1
9	32106A-9	Lower Bracket Bar	1
10	TS-1504021	Hex Socket Head Cap Screw	M8x12	1
11	32106A-11	Support Arm.....	1
12	TS-0640091	Hex Nut	3/8"	1
13	TS-0720091	Spring Washer	3/8".....	1
14	TS-1504041	Hex Socket Head Cap Screw	M8x20	1
15	32106A-16	Lock Bolt with Knob	M8	1
16	32106A-17	Spacer.....	1

13.5.1 Table and Base Assembly (All Models) – Exploded View

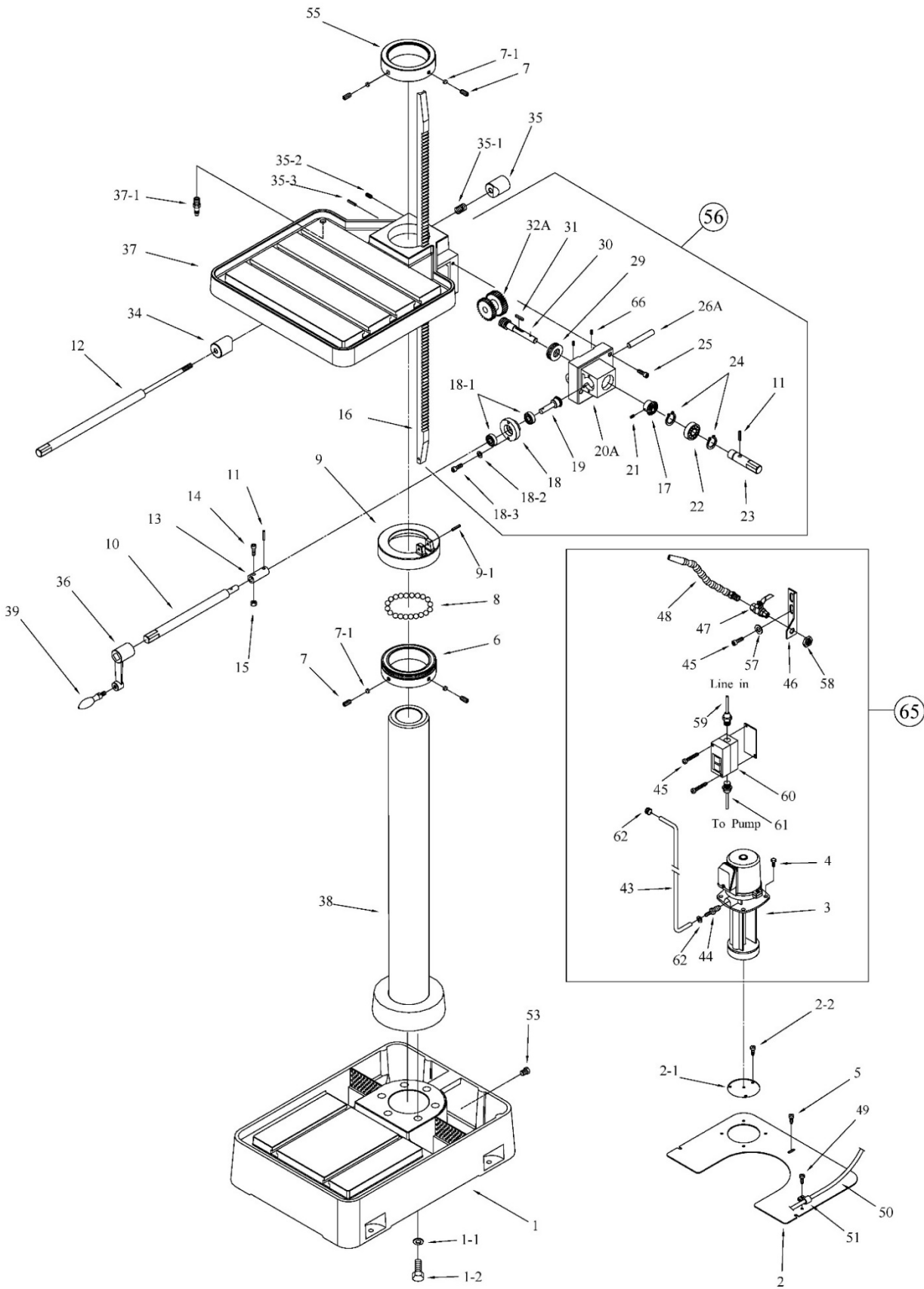

13.5.2 Table and Base Assembly (All Models) – Parts List

Index No.	Part No.	Description	Size	Qty
1	J-5510288A	Base		1
1-1	TS-0720111	Lock Washer	1/2"	6
1-2	TS-0070031	Hex Cap Screw	1/2" x 1-1/2"	6
2	J-5510289	Coolant Cover Plate		1
2-1	20EVS-C2-1	Small Cover		1
2-2	20EVS-C4	Screw w/Washer	1/4"	3
3	5510456	Coolant Pump	115V/230V, 1P	1
	5512103	Coolant Pump	220/440V, 3P	1
4	TS-1482011	Hex Bolt	M6x10	4
5	5517388	Pan Head Screw		3
6	5510293A	Ball Seat		1
7	5510294	Set Screw	3/8"	4
7-1	5517389	Brass Block		4
8	5510295	Ball Bearing	3/8"	38
9	J-5510296A	Lock Ring		1
9-1	5517390	Pin	M4	1
10	5516859	Table Raiser Shaft		1
11	5510298	Spring Pin	4x20mm	1
12	5516858	Table Clamp Shaft		1
13	5516860	Table Raiser Coupling		1
14	5510300	Socket Head Screw		1
15	TS-0561011	Nut	1/4"	1
16	5510302	Rack		1
17	5514663	Large Bevel Gear		1
18	5517391	Bearing Housing		1
18-1	BB-6202ZZ	Ball Bearing	6202ZZ	2
18-2	TS-0720071	Washer	1/4"	2
18-3	TS-1482041	Cap Screw	M6x20	2
19	5510304	Small Bevel Gear		2
20A	J-5510305A	Bracket Cover		1
21	TS-0267041	Set Screw	1/4"x3/8"	1
22	BB-6005ZZ	Ball Bearing	6005zz	1
23	5510308	Shaft		1
24	5510309	C-Ring	S25	2
25	TS-1504071	Hex Socket Cap Screw	M8x35	3
26A	5510311A	Shaft		1
29	BB-51102	Bearing	51102	1
30	5510315	Table Raise Worm		1
31	5510316	Key	4x4x20mm	1
32A	5510317A	Worm Gear Assembly		1
34	5510319	Front Cam Lock		1
35	5510320	Rear Cam Lock		1
35-1	5517396	Spring		1
35-2	TS-1523071	Set Screw	M6x25	1
35-3	5517398	Pin	5x25mm	2
36	J-5510321	Table Raise Crank		2
37	J-5510322	Table		1
37-1	5517399	Hose Coupler (Return)	1/2"	1
38	5510323A	Column		1
39	5510324	Table Raise Handle		1
43	5510328	Clear Vinyl Hose	3/8"	1
44	5510329	Hose Coupler (Supply)	3/8"	1
45	5512112	Socket Head Cap Screw	#10-32 x 1"	4
46	5510331	Mounting Bracket		1
47	5510332	Valve		1
48	5510333	Flexible Nozzle		1

Index No.	Part No.	Description	Size	Qty
49	5517400	Pan Head Screw		1
50	5517401	Clear Vinyl Hose	1/2"	1
51	5517402	Hose Clamp		1
53	5517404	Drain Plug	3/8 NPT	1
55	J-5517406	Rack Collar		1
56	5513932	Table Raiser Assembly		1
57	9057451	Flat Washer	#10	2
58	5517488	Hex Nut	1/2"	1
59	5517489	Power Cord		1
60	5517490	Switch Assembly		1
61	5517491	Pump Cord	1 Phase	1
	5517492	Pump Cord	3 Phase	1
62	5517493	Hose Clamp, Rad. Type		2
65	5512104	Coolant System Complete *	1/8 HP, 115/230V, 1 Phase	1
	5508071	Coolant System Complete *	1/8 HP, 230/460V, 3 Phase	1
66	TS-1522021	Socket Set Screw	M5x8	2
	J2221-SBCA	Support Bearing Collar Assembly (includes #6,7,7-1,8,9,9-1)		1

* optional accessory

14.0 Electrical connections

Similar diagrams are affixed inside electrical cabinet door. In case of discrepancy, diagrams on machine take precedence.

14.1 JDP-20VS-1 and JDP-20VS-3 wiring diagram

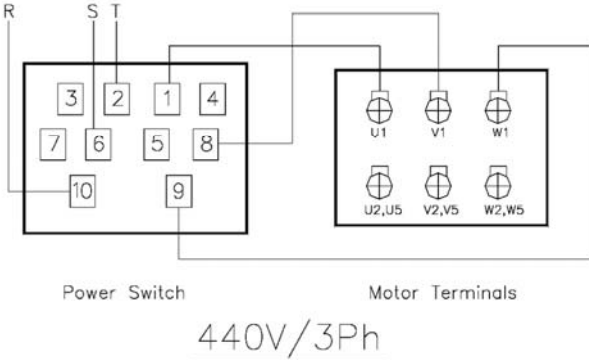
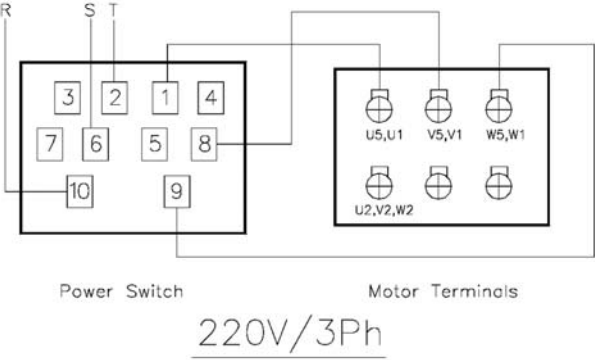
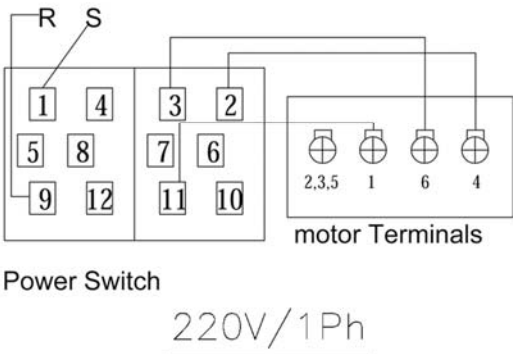
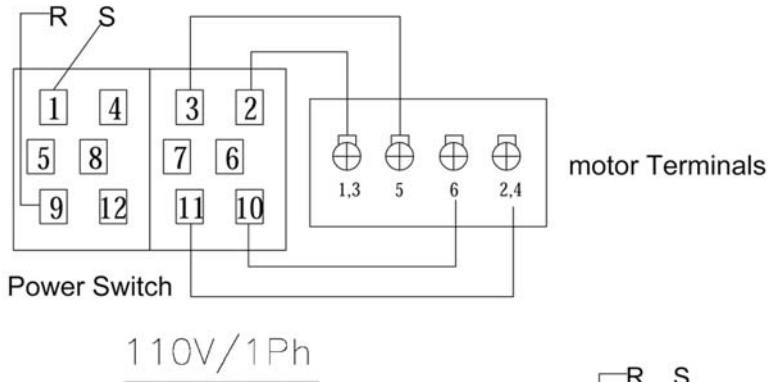

14.2 JDP20VST wiring diagram

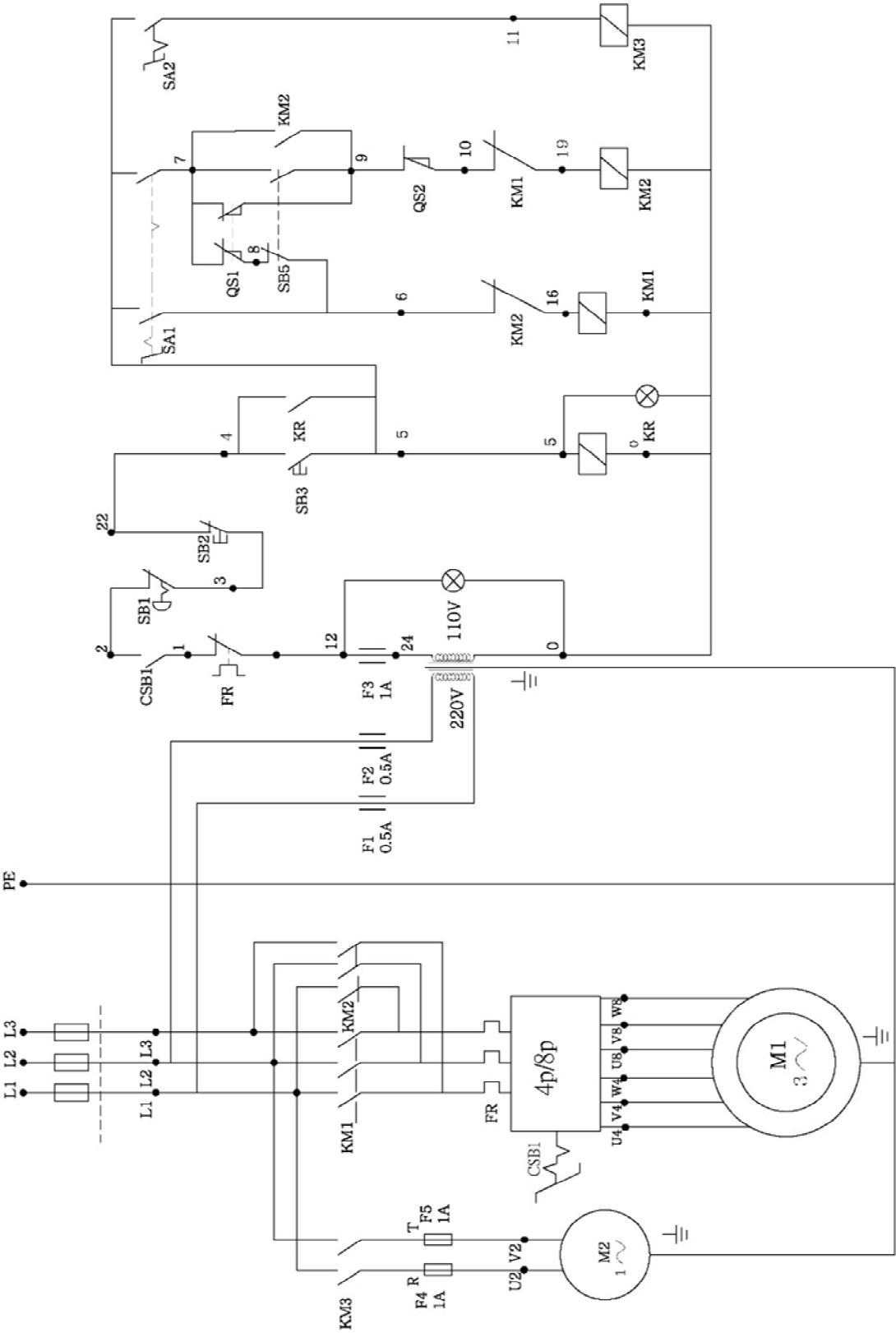

15.0 Warranty and Service

JET warrants every product it sells against manufacturers' defects. If one of our tools needs service or repair, please contact Technical Service by calling 1-800-274-6846, 8AM to 5PM CST, Monday through Friday.

Warranty Period

The general warranty lasts for the time period specified in the literature included with your product or on the official JET branded website.

- JET products carry a limited warranty which varies in duration based upon the product. (See chart below)
- Accessories carry a limited warranty of one year from the date of receipt.
- Consumable items are defined as expendable parts or accessories expected to become inoperable within a reasonable amount of use and are covered by a 90 day limited warranty against manufacturer's defects.

Who is Covered

This warranty covers only the initial purchaser of the product from the date of delivery.

What is Covered

This warranty covers any defects in workmanship or materials subject to the limitations stated below. This warranty does not cover failures due directly or indirectly to misuse, abuse, negligence or accidents, normal wear-and-tear, improper repair, alterations or lack of maintenance. JET woodworking machinery is designed to be used with Wood. Use of these machines in the processing of metal, plastics, or other materials outside recommended guidelines may void the warranty. The exceptions are acrylics and other natural items that are made specifically for wood turning.

Warranty Limitations

Woodworking products with a Five Year Warranty that are used for commercial or industrial purposes default to a Two Year Warranty. Please contact Technical Service at 1-800-274-6846 for further clarification.

How to Get Technical Support

Please contact Technical Service by calling 1-800-274-6846. **Please note that you will be asked to provide proof of initial purchase when calling.** If a product requires further inspection, the Technical Service representative will explain and assist with any additional action needed. JET has Authorized Service Centers located throughout the United States. For the name of an Authorized Service Center in your area call 1-800-274-6846 or use the Service Center Locator on the JET website.

More Information

JET is constantly adding new products. For complete, up-to-date product information, check with your local distributor or visit the JET website.

How State Law Applies

This warranty gives you specific legal rights, subject to applicable state law.

Limitations on This Warranty

JET LIMITS ALL IMPLIED WARRANTIES TO THE PERIOD OF THE LIMITED WARRANTY FOR EACH PRODUCT. EXCEPT AS STATED HEREIN, ANY IMPLIED WARRANTIES OF MERCHANTABILITY AND FITNESS FOR A PARTICULAR PURPOSE ARE EXCLUDED. SOME STATES DO NOT ALLOW LIMITATIONS ON HOW LONG AN IMPLIED WARRANTY LASTS, SO THE ABOVE LIMITATION MAY NOT APPLY TO YOU.

JET SHALL IN NO EVENT BE LIABLE FOR DEATH, INJURIES TO PERSONS OR PROPERTY, OR FOR INCIDENTAL, CONTINGENT, SPECIAL, OR CONSEQUENTIAL DAMAGES ARISING FROM THE USE OF OUR PRODUCTS. SOME STATES DO NOT ALLOW THE EXCLUSION OR LIMITATION OF INCIDENTAL OR CONSEQUENTIAL DAMAGES, SO THE ABOVE LIMITATION OR EXCLUSION MAY NOT APPLY TO YOU.

JET sells through distributors only. The specifications listed in JET printed materials and on official JET website are given as general information and are not binding. JET reserves the right to effect at any time, without prior notice, those alterations to parts, fittings, and accessory equipment which they may deem necessary for any reason whatsoever. JET® branded products are not sold in Canada by JPW Industries, Inc.

Product Listing with Warranty Period

90 Days – Parts; Consumable items
1 Year – Motors; Machine Accessories
2 Year – Metalworking Machinery; Electric Hoists, Electric Hoist Accessories; Woodworking Machinery used for industrial or commercial purposes
5 Year – Woodworking Machinery
Limited Lifetime – JET Parallel clamps; VOLT Series Electric Hoists; Manual Hoists; Manual Hoist Accessories; Shop Tools; Warehouse & Dock products; Hand Tools; Air Tools

NOTE: JET is a division of JPW Industries, Inc. References in this document to JET also apply to JPW Industries, Inc., or any of its successors in interest to the JET brand.

This page intentionally left blank.



427 New Sanford Road
LaVergne, Tennessee 37086
Phone: 800-274-6848
www.jettools.com