

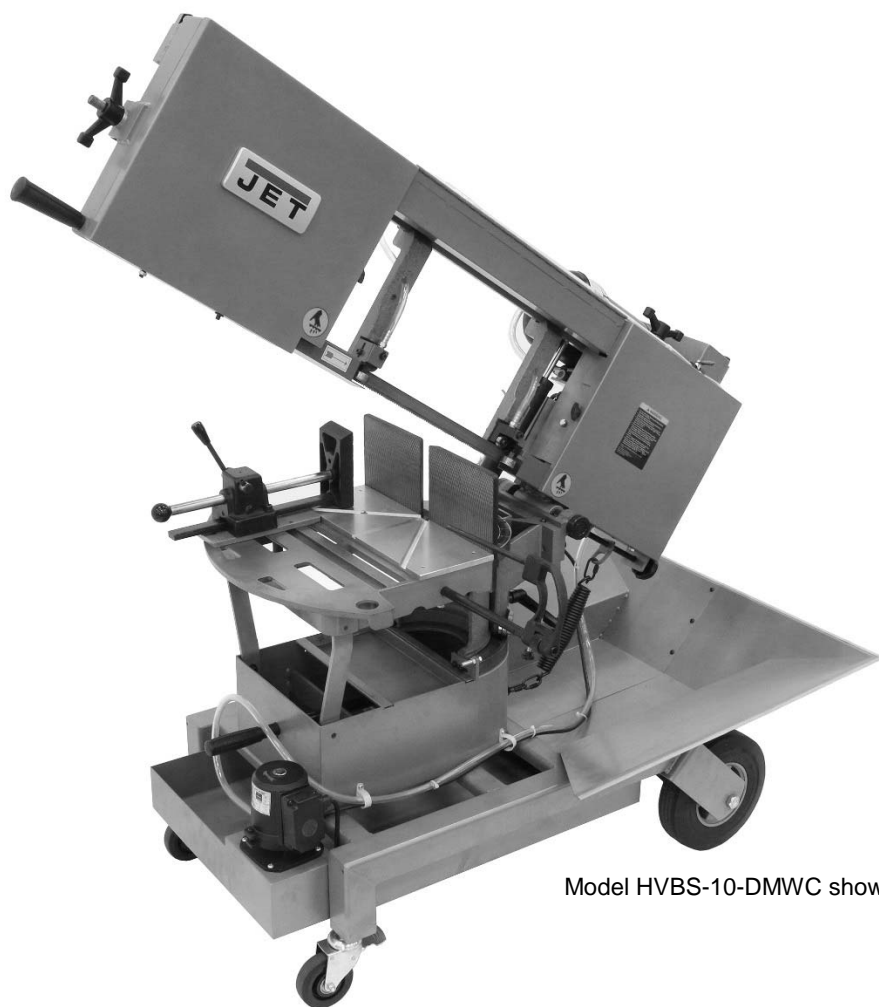

Operating Instructions and Parts Manual Portable Dual Mitering Band Saws

Models HVBS-8-DMW, HVBS-10-DMW, HVBS-10-DMWC



Model HVBS-10-DMWC shown

JET
427 New Sanford Road
LaVergne, Tennessee 37086
Ph.: 800-274-6848
www.jettools.com

Part No. M-424460
Edition 1 12/2016
Copyright © 2016 JET



1.0 IMPORTANT SAFETY INSTRUCTIONS

WARNING – To reduce risk of injury:

1. Read and understand the entire owner's manual before attempting assembly or operation.
2. Read and understand the warnings posted on the machine and in this manual. Failure to comply with all of these warnings may cause serious injury.
3. Replace the warning labels if they become obscured or removed.
4. This band saw is designed and intended for use by properly trained and experienced personnel only. If you are not familiar with the proper and safe operation of a band saw, do not use until proper training and knowledge have been obtained.
5. Do not use this machine for other than its intended use. If used for other purposes, JET disclaims any real or implied warranty and holds itself harmless from any injury that may result from that use.
6. Always wear ANSI Z87.1 approved safety glasses or face shield while using this band saw. (Everyday eyeglasses only have impact resistant lenses; they are not safety glasses.)
7. Before operating this machine, remove tie, rings, watches and other jewelry, and roll sleeves up past the elbows. Do not wear loose clothing. Confine long hair. Non-slip footwear or anti-skid floor strips are recommended. Do not wear gloves.
8. Wear ear protectors (plugs or muffs) if noise exceeds safe levels.
9. **CALIFORNIA PROPOSITION 65 WARNING:** This product contains chemicals known to the State of California to cause cancer, or birth defects or other reproductive harm.
10. This product, when used for welding, cutting, or working with metal, produces fumes, gases, or dusts which contain chemicals known to the State of California to cause birth defects and, in some cases, cancer. (California Health and Safety Code Section 25249.5 et seq.)
11. Make certain the switch is in the OFF position before connecting the machine to the power supply.
12. Make certain the machine is properly grounded.
13. Make all machine adjustments or maintenance with the machine unplugged from the power source.
14. Remove adjusting keys and wrenches. Form a habit of checking to see that keys and adjusting wrenches are removed from the machine before turning it on.
15. Keep safety guards in place at all times when the machine is in use. If removed for maintenance purposes, use extreme caution and replace the guards immediately after completion of maintenance.
16. Check damaged parts. Before further use of the machine, a guard or other part that is damaged should be carefully checked to determine that it will operate properly and perform its intended function. Check for alignment of moving parts, binding of moving parts, breakage of parts, mounting and any other conditions that may affect its operation. A guard or other part that is damaged should be properly repaired or replaced.
17. Provide for adequate space surrounding work area and non-glare, overhead lighting.
18. Keep the floor around the machine clean and free of scrap material, oil and grease.
19. Keep visitors a safe distance from the work area. Keep children away.
20. Make your workshop child proof with padlocks, master switches or by removing starter keys.
21. Give your work undivided attention. Looking around, carrying on a conversation and "horse-play" are careless acts that can result in serious injury.
22. Maintain a balanced stance at all times so that you do not fall into the blade or other moving parts. Do not overreach or use excessive force to perform any machine operation.
23. Use the right tool at the correct speed and feed rate. Do not force a tool or attachment to do a job for which it was not designed. The right tool will do the job better and more safely.
24. Use recommended accessories; improper accessories may be hazardous.
25. Maintain tools with care. Keep saw blades sharp and clean for the best and safest performance. Follow instructions for lubricating and changing accessories.
26. Maintain proper adjustment of blade tension, blade guides and thrust bearings.
27. Turn off the machine before cleaning. Use a brush to remove chips or debris — do not use your hands.

28. Do not stand on the machine. Serious injury could occur if the machine tips over.
29. Never leave the machine running unattended. Turn the power off and do not leave the machine until it comes to a complete stop.
30. Remove loose items and unnecessary work pieces from the area before starting the machine.
31. Never hand hold the material. Always use the vise and clamp it securely.
32. Be sure that blade is not in contact with workpiece when motor is started. Allow motor to come up to speed before bringing blade into contact with workpiece.
33. Avoid contact with coolant, especially guarding your eyes.
34. Never reach around or over saw blade during operation. Keep hands and fingers away from blade area.
35. Do not remove jammed pieces until blade has stopped.
36. Don't use in dangerous environment. Don't use power tools in damp or wet location, or expose them to rain. Keep work area well lighted.
37. Use proper extension cord. Make sure your extension cord is in good condition. When using an extension cord, be sure to use one heavy enough to carry the current your product will draw. An undersized cord will cause a drop in line voltage resulting in loss of power and overheating. Table 2 (sect. 6.3) shows correct size to use depending on cord length and nameplate ampere rating. If in doubt, use the next heavier gage. The smaller the gage number, the heavier the cord.

Familiarize yourself with the following safety notices used in this manual:

CAUTION This means that if precautions are not heeded, it may result in minor injury and/or possible machine damage.

WARNING This means that if precautions are not heeded, it may result in serious, or possibly even fatal, injury.

1.1 On-off switch padlock

To avoid accidental starting by young children or others not qualified to use the tool, the use of a padlock (not provided) is required.

To lock out the on-off switch (Figure 2-1):

1. Open padlock.
2. Insert through hole in switch guard.
3. Close padlock.
4. Store key in a safe place out of the reach of children.

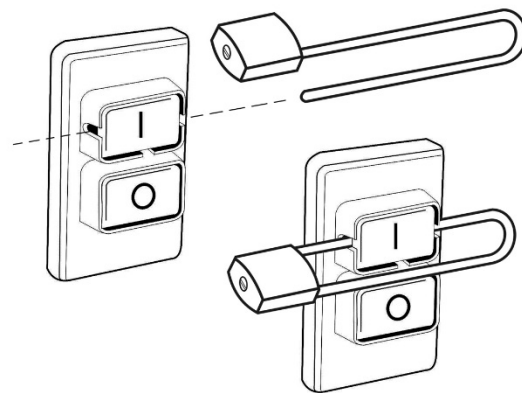

Figure 1-1

2.0 Table of contents

Section	Page
1.0 IMPORTANT SAFETY INSTRUCTIONS	2
1.1 On-off switch padlock	3
2.0 Table of contents	4
3.0 About this manual	5
4.0 Specifications for HVBS-DMW series Band Saws	6
5.0 Setup and assembly	8
5.1 Shipping contents	8
5.2 Unpacking and cleanup	8
5.3 Assembly (all models)	8
5.4 Additional assembly (10-inch models only)	8
6.0 Electrical connections	8
6.1 GROUNDING INSTRUCTIONS	9
6.2 Voltage conversion	9
6.3 Extension cords	10
7.0 Adjustments	10
7.1 Handle adjustment	10
7.2 Bow swivel	10
7.3 Blade speed adjustment	10
7.4 Blade guide arms	11
7.5 Blade replacement	11
7.6 Blade guide bearings	12
7.7 Blade tension and tracking	12
7.8 Blade-to-table squareness	13
7.9 Setting feed rate	13
7.10 Counterbalance spring	14
7.11 Vertical bow position	14
7.12 Auto shut-off adjustment	14
7.13 Vise positioning	15
7.14 Work stop	15
8.0 Operation	15
8.1 Blade selection	15
8.2 Blade break-in	15
8.3 General operating procedure	16
8.4 Evaluating cutting efficiency	16
9.0 User-maintenance	17
9.1 Lubrication	17
9.2 Coolant level (HVBS-10DMW-C)	17
9.3 Additional servicing	17
10.0 Troubleshooting HVBS-DM series Band Saws	18
11.0 Replacement Parts	19
11.1.1 HVBS-8-DMW Bow Assembly – Exploded View	20
11.1.2 HVBS-8-DMW Table Assembly – Exploded View	21
11.1.3 HVBS-8-DMW Motor and Support Arm Assembly – Exploded View	22
11.1.4 HVBS-8-DMW Vise and Table Assembly – Exploded View	23
11.1.5 HVBS-8-DMW Base Assembly – Exploded View	23
11.1.6 HVBS-8-DMW – Parts List	24
11.2.1 HVBS-10-DMW/DMWC Bow Assembly – Exploded View	28
11.2.2 HVBS-10-DMW/DMWC Table Assembly – Exploded View	29
11.2.3 HVBS-10-DMW/DMWC Motor and Support Arm Assembly – Exploded View	30
11.2.4 HVBS-10-DMW/DMWC Vise and Table Assembly – Exploded View	31
11.2.5 HVBS-10-DMW/DMWC Base Assembly – Exploded View	32
11.2.6 HVBS-10-DMW/DMWC – Parts List	33
12.0 Electrical Connections for HVBS-DMW Band Saws	37
13.0 Warranty and service	38

3.0 About this manual

This manual is provided by JET, covering the safe operation and maintenance procedures for a JET Model HVBS-DMW series Portable Band Saw. This manual contains instructions on installation, safety precautions, general operating procedures, maintenance instructions and parts breakdown. Your machine has been designed and constructed to provide consistent, long-term operation if used in accordance with the instructions as set forth in this document.

If there are questions or comments, please contact your local supplier or JET. JET can also be reached at our web site: www.jettools.com.

Retain this manual for future reference. If the machine transfers ownership, the manual should accompany it.

 **WARNING Read and understand the entire contents of this manual before attempting assembly or operation! Failure to comply may cause serious injury!**

Register your product using the mail-in card provided, or register online: <http://www.jettools.com/us/en/service-and-support/warranty/registration/>

4.0 Specifications for HVBS-DMW series Band Saws

Model number	HVBS-8-DMW		HVBS-10-DMW		HVBS-10-DMWC	
Stock number	424460		424463		424465	
Motor and Electricals						
Motor type	TEFC induction					
Horsepower	3/4 HP (0.56 kW)		1 HP (0.75 kW)		1 HP (0.75 kW)	
Phase	1					
Voltage	115 / 230V (prewired 115V)					
Cycle	60 Hz					
Listed FLA (full load amps)	9 / 4.5		14 / 7			
Motor speed	1720 RPM					
Start capacitor	300MFD 125VAC					
Power cord	SJT 14AWGx3C, 6ft.					
Power plug installed	115V					
Power transfer	Step pulleys with v-belt, to gear reducer box					
Gear ratio	1:40		1:50			
Recommended circuit size ¹	15A		20A (115V), 15A (230V)			
Sound emission without load ²	70 dB		75 dB			
Coolant pump	n/a		n/a		1/8HP 2P 1PH 0.78/0.4A 115/230V	
Capacities						
Tubing & Solids	Round	90 deg.	8 in. (200 mm)		10 in. (250 mm)	
		+/-45 deg.	6 in. (150 mm)		6-1/2 in. (165 mm)	
	Rectangle	90 deg.	6-1/2 x 8 in. (165 x 200 mm)		8 x 9 in. (200 x 228 mm)	
		+45 deg.	7 x 5-1/2 in. (175 x 137 mm)		8 x 5 in. (200 x 127 mm)	
		-45 deg.	6 x 5-1/2 in. (150 x 137 mm)		8 x 5-1/2 in. (200 x 140 mm)	
	Square	90 deg.	7 x 7 in. (175 x 175 mm)		8 x 8 in. (200 x 200 mm)	
		+45 deg.	5-1/2 x 5-1/2 in. (137 x 137 mm)		5-1/2 x 5-1/2 in. (137 x 137 mm)	
		-45 deg.	5-1/2 x 5-1/2 in. (137 x 137 mm)		5 x 5 in. (127 x 127 mm)	
	Vertical cutting capacity		12 x 8 in. (305 x 200 mm)		13 x 10 in. (330 x 254 mm)	
Bow swivel		+/- 45 deg.				
Gearbox oil capacity		330 cc (0.07 gal.)		430 cc (0.095 gal.)		
Coolant capacity		n/a		n/a		32 L (7 gal.)
Blade						
Blade type and size		6/10T, 3/4 x 0.035 x 102.9 in. (19 x 0.9 x 2616 mm)		5/8T, 1 x 0.035 x 120 in. (27 x 0.9 x 3048 mm)		
Blade speeds		64, 132, 247 SFPM (19.5, 40, 75 mpm)				
Main materials						
Bow and stand		steel				
Blade wheels		cast iron				
Tires		rubber				
Pulleys		cast iron				
Table		cast iron and aluminum				

	HVBS-8-DMW	HVBS-10-DMW	HVBS-10-DMWC
Dimensions			
Blade wheel diameter	37-1/8 in. (943 mm)	41.73 in. (1060 mm)	
Distance table from floor	27-1/2 in. (697 mm)	29 in. (728 mm)	
Overall assembled (LxWxH)	54 x 25 x 42 in. (1381 x 639 x 1060mm)	63 x 27 x 45 in. (1597.9x676x1144mm)	70 x 35 x 45 in. (1784 x 878 x 1144mm)
Shipping dimensions (LxWxH)	56.3 x 27.6 x 43.3 in. (1430 x700 x 1100 mm)	61 x 29.6 x 45.5 in. (1550 x 750 x 1155 mm)	
Weights			
Net weight	390 lb. (177 kg)	511 lb. (232 kg)	
Shipping weight	454 lb. (206 kg)	582 lb. (264 kg)	

Table 1

¹ subject to local and national electrical codes.

² The specified values are emission levels and are not necessarily to be seen as safe operating levels. As workplace conditions vary, this information is intended to allow the user to make a better estimation of the hazards and risks involved only.

L = length, W = width, H = height

n/a = not applicable

The specifications in this manual were current at time of publication, but because of our policy of continuous improvement, JET reserves the right to change specifications at any time and without prior notice, without incurring obligations.

5.0 Setup and assembly

⚠WARNING Read and understand all instructions before attempting assembly. Band Saw must be disconnected from power during all assembly procedures. Failure to comply may cause serious injury.

5.1 Shipping contents

- 1 Band saw
- 2 Wheels
- 1 Work stop assembly
- 1 Vertical cutting platform
- 1 Chip bin (10" models only)

5.2 Unpacking and cleanup

1. Inspect all contents for shipping damage. Compare contents of shipping carton with contents list in this manual. Report any damage or part shortages to your distributor.
2. Do not discard packing material until saw is assembled and running properly.
3. Remove rust protectant from exposed surfaces, such as table, vise assembly, etc., with a clean rag and a cleaner/degreaser. Apply a light coat of oil on these surfaces to inhibit rust.

5.3 Assembly (all models)

1. Remove any straps or braces holding saw to pallet, and carefully raise saw from pallet, using properly rated lifting equipment (hoist or forklift) with straps.
2. Remove fasteners from the wheel flanges of carriage. Position wheel between flanges, and insert hex bolt with spacer on each side, as shown in Figure 6-3. Secure with hex nut and washer.

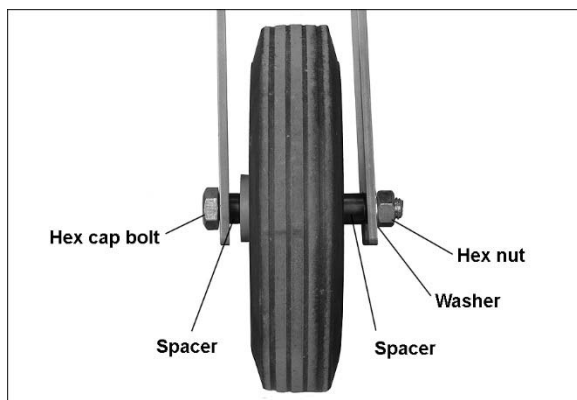

Figure 5-1: installing wheel

3. Install work stop rod (A₁, Figure 5-2) into hole beneath table and tighten set screw. Install work stop onto rod threads by rotating collar (A₂). Secure position of work stop by tightening set screw (A₃) onto rod flat.

4. If closer reach is needed toward blade, insert small rod (A₄) and tighten with wrench on rod flat.

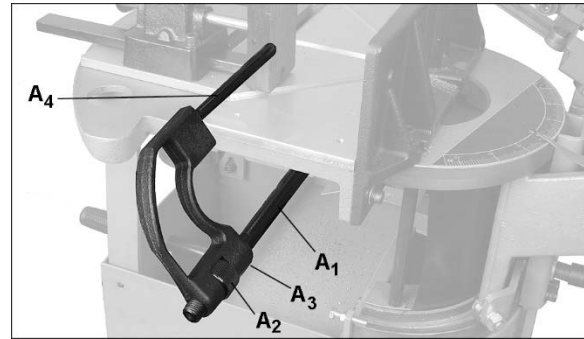

Figure 5-2: installing work stop

5.4 Additional assembly (10-inch models only)

Install chip bin at back of saw base. (See Figure 11-10 and manual cover photo for positioning.)

5.4.1 Coolant preparation (HVBS-10-DMWC only)

⚠CAUTION Coolant tray must be filled high enough to submerge pump impeller. Failure to do this may damage pump. Periodically check and maintain coolant level.

Use of a water-soluble coolant will increase cutting efficiency and prolong blade life. Do not use black cutting oil as a substitute. Change cutting oil often and follow manufacturer's instructions as to its uses and precautions.

1. Disconnect machine from power source.
2. Pour approximately 32 L (7 gal) of coolant into coolant tray.
3. Make sure coolant hoses are properly connected at each end.

⚠CAUTION When cutting magnesium, never use soluble oils or emulsions (oil-water mix) as water will greatly intensify any accidental magnesium chip fire. Consult your coolant supplier for coolant recommendations when cutting magnesium.

6.0 Electrical connections

⚠WARNING Electrical connections must be made by a qualified electrician in compliance with all relevant codes. This machine must be properly grounded to help prevent electrical shock and possible fatal injury.

The HVBS-DMW series Band Saws are rated at 115/230V power, and are pre-wired for 115 volt. The band saw comes with a plug designed for use on a

circuit with a *grounded outlet* that looks like the one pictured in **A**, Figure 6-1.

Before connecting to power source, be sure switch is in *off* position.

It is recommended that the **HVBS-8DMW** be connected to a dedicated 15 amp circuit with circuit breaker or fuse. If connected to a circuit protected by fuses, use time delay fuse marked "D".

It is recommended that the **HVBS-10DMW**, when operated on 115V, be connected to a dedicated 20 amp circuit with circuit breaker or fuse. When operated on 230V power, connect it to a dedicated 15 amp circuit with circuit breaker or fuse. If connected to a circuit protected by fuses, use time delay fuse marked "D".

NOTE: Local codes take precedence over recommendations.

6.1 GROUNDING INSTRUCTIONS

This machine must be grounded. In the event of a malfunction or breakdown, grounding provides a path of least resistance for electric current to reduce the risk of electric shock. This tool is equipped with an electric cord having an equipment-grounding conductor and a grounding plug. The plug must be plugged into a matching outlet that is properly installed and grounded in accordance with all local codes and ordinances.

Do not modify the plug provided - if it will not fit the outlet, have the proper outlet installed by a qualified electrician.

Improper connection of the equipment-grounding conductor can result in a risk of electric shock. The conductor with insulation having an outer surface that is green with or without yellow stripes is the equipment-grounding conductor. If repair or replacement of the electric cord or plug is necessary, do not connect the equipment-grounding conductor to a live terminal.

⚠WARNING Check with a qualified electrician or service personnel if the grounding instructions are not completely understood, or if in doubt as to whether the tool is properly grounded. Failure to comply may cause serious or fatal injury.

Use only 3-wire extension cords that have 3-prong grounding plugs and 3-pole receptacles that accept the tool's plug.

Repair or replace damaged or worn cord immediately.

When operated at **115-volt**, this tool is intended for use on a circuit that has an outlet that looks like the one illustrated in **A**, Figure 6-1. An adapter, shown in **B** and **C**, may be used to connect this plug to a 2-pole receptacle as shown in **B** if a properly grounded outlet is not available. The temporary adapter should be used only until a properly

grounded outlet can be installed by a qualified electrician. The green-colored rigid ear, lug, and the like, extending from the adapter must be connected to a permanent ground such as a properly grounded outlet box. **Note: In Canada, the use of a temporary adaptor is not permitted by the Canadian Electrical Code, C22.1.**

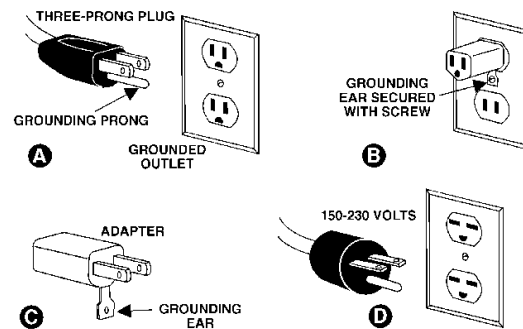

Figure 6-1: grounding

When operated at **230-volt**, this tool is intended for use on a circuit that has an outlet that looks like the one illustrated in **D**, Figure 6-1. The tool has a grounding plug that looks like the plug illustrated in **D**. Make sure the tool is connected to an outlet having the same configuration as the plug. No adapter is available or should be used with this tool. If the tool must be reconnected for use on a different type of electric circuit, the reconnection should be made by qualified service personnel; and after reconnection, the tool should comply with all local codes and ordinances.

6.2 Voltage conversion

The Band Saw is prewired for 115 volt. To change incoming leads for 230 volt operation:

1. Open main motor junction box cover, and change leads based on wiring diagram inside cover. This diagram is also shown in Figure 6-2. (NOTE: In case of discrepancy, diagram on machine takes precedence.) Reinstall cover.
2. (**Model HVBS-10DMWC only:** Remove coolant pump junction box cover, and change incoming leads for coolant pump, based on diagram shown in Figure 6-2. Reinstall cover.)
3. The plug on end of power cord must be replaced with a UL/CSA listed plug rated for 230 volt operation.

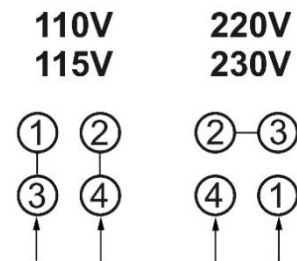

Figure 6-2: voltage conversion

6.3 Extension cords

The use of extension cords is discouraged; try to position machines near the power source. If an extension cord is necessary, make sure it is in good condition. When using an extension cord, be sure to use one heavy enough to carry the current your product will draw. An undersized cord will cause a drop in line voltage resulting in loss of power and overheating.

Table 2 shows correct size to use depending on cord length and nameplate ampere rating. If in doubt, use the next heavier gauge. The smaller the gauge number, the heavier the cord.

Ampere Rating		Volts	Total length of cord in feet			
More Than	Not More Than		25	50	100	150
		120	25	50	100	150
		240	50	100	200	300
			AWG			
0	6		18	16	16	14
6	10		18	16	14	12
10	12		16	16	14	12
12	16		14	12	Not Recommended	

Table 2: Extension cord recommendations

7.0 Adjustments

⚠WARNING Always disconnect band saw from power source before making adjustments, unless indicated otherwise.

7.1 Handle adjustment

The plastic handles for swivel (A, Figure 7-1) and blade guide arm positioning are adjustable to prevent obstruction of other parts. Pull out on handle and rotate it on pin, then release it, allowing it to resettle on pin.

7.2 Bow swivel

1. Disconnect band saw from power source.
2. Loosen handle (A, Figure 7-1) and rotate bow to desired angle on scale (B).
3. Confirm accuracy of angle by cutting a test piece or using an angle measuring device against blade and fixed vise jaw. If scale needs adjustment, adjust pointer.
4. Verify accuracy of 45-degree left and right stop screws (C). Adjust if needed.
5. Tighten handle (A) before operating saw.

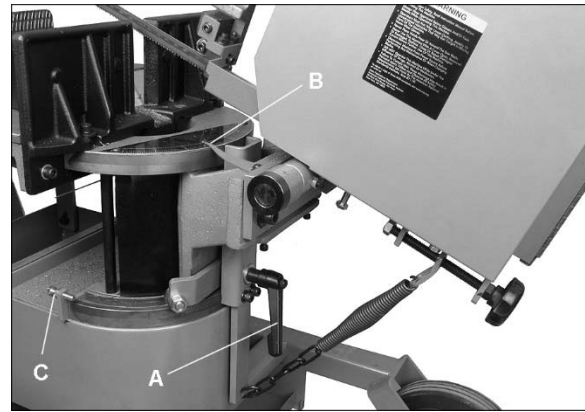

Figure 7-1

7.3 Blade speed adjustment

1. Disconnect band saw from power source.
2. Place bow in horizontal position.
3. Open pulley box and turn handle (D, Figure 7-2) counterclockwise to release tension on drive belt.
4. Move belt to desired pulley combination. Refer to chart inside pulley box (reproduced in Figure 7-3).
5. Turn handle (D) clockwise to tension belt. Finger pressure on belt midway between pulleys should cause approximately 1/2-inch deflection. Do not overtighten belt.
6. Close pulley box before operating.

General rule for band saw blade speed: The harder the material being cut, the slower the blade speed. Refer to a machinist's handbook for recommended speeds for specific materials.

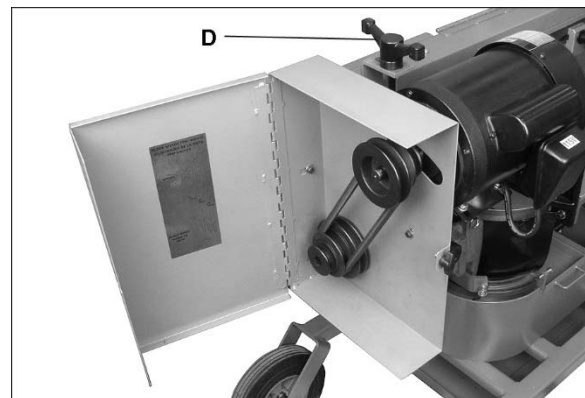

Figure 7-2: blade speed adjustment

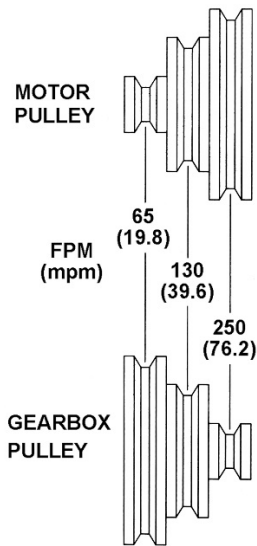

Figure 7-3: blade speeds (rounded off)

7.4 Blade guide arms

1. Disconnect band saw from power source.
2. The fixed blade guide arm (E, Figure 7-4) should be positioned as close to work area as possible, without interfering when bow is swiveled to an angle. Loosen screw (E₁) and slide arm as needed. Tighten screw before operating. (Once the fixed guide arm is properly positioned, it can generally remain in that position for all operations.)
3. The movable blade guide arm (F) should be as close as possible without interference to material being cut. Loosen handle (F₁) and slide arm as needed. Retighten handle before operating.

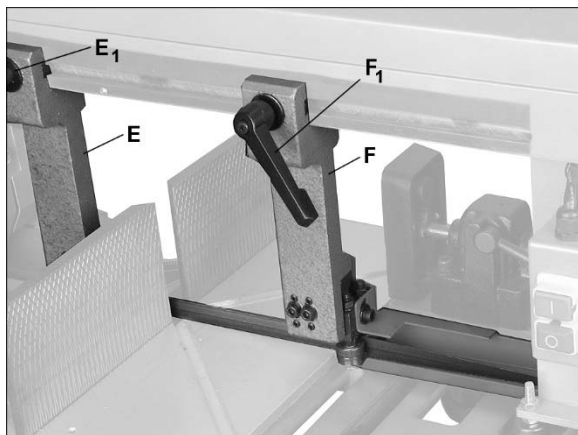

Figure 7-4: blade guide arm adjustment

7.5 Blade replacement

A general-use variable-tooth blade is provided with this band saw.

Choice of blade pitch is governed by thickness of workpiece: the thinner the workpiece, the more teeth advised. A minimum of 3 teeth should engage workpiece at all times. If blade teeth are so far apart

that they straddle the work, severe damage to workpiece and blade can result.

1. Disconnect band saw from power source.
2. Raise bow to convenient position.
3. Open wheel guards and prop them open with the attached rods (G, Figure 7-5). Remove red blade guards (H).

⚠ WARNING It is essential that red blade guards be re-installed after new blade has been fitted. Failure to comply may cause serious injury.

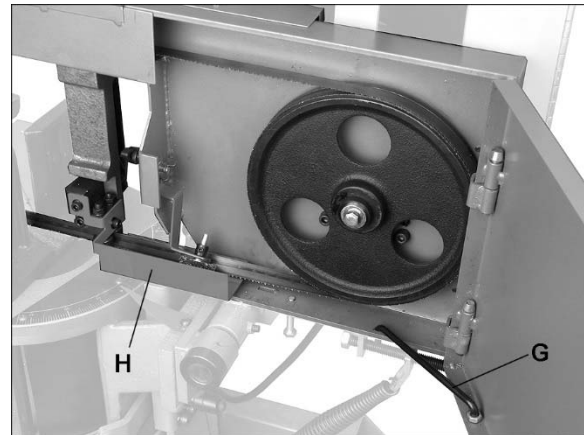

Figure 7-5

4. Back off the eccentric bearing guides (see sect. 7.6 for detailed instructions).
5. Release tension on blade by turning tension handle (P, Figure 7-8) counterclockwise. Remove blade. (Use leather gloves when handling sharp blades).
6. Install new blade between blade guide assemblies and around each wheel. Make sure blade teeth are pointing in proper direction. See Figure 7-6. If they are not, twist blade inside-out.
7. Increase blade tension just enough to hold blade on wheels. Make sure back of blade rests lightly against shoulder of both wheels. Twist blade slightly to allow it to slip into guides.

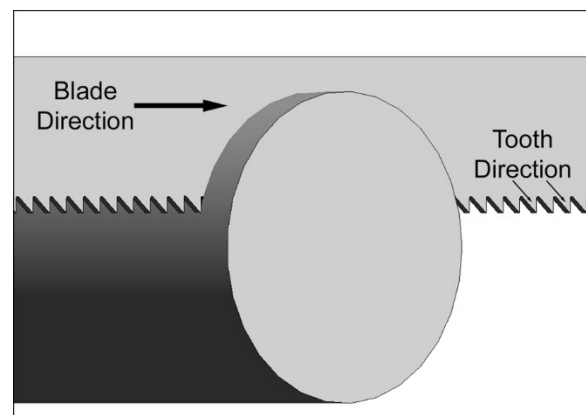

Figure 7-6

8. Install red blade guards.
9. Tension blade fully (see sect. 7.7)
10. Place two to three drops of lightweight oil on blade.
11. Adjust blade guide bearings (see sect. 7.6).
12. Connect machine to power source and operate it to make sure blade is tracking properly (sect 7.7.2).
13. Follow blade break-in procedures (sect. 8.2).

7.6 Blade guide bearings

1. Disconnect machine from power source.
2. Loosen screw (J₁, Figure 7-7) and adjust back bearing (J₂) to approximately 0.002 to 0.003 inches from back edge of blade. Tighten screw (J₁).
3. Inside bearing (K₁) is fixed. Outside bearing (K₂) rotates on an eccentric shaft. Loosen nut (K₃) and rotate lower nut (K₄) to adjust eccentric bearing to a clearance of 0.001 inches from blade. Retighten nut (K₃).
4. Repeat above steps for opposite blade guide assembly.

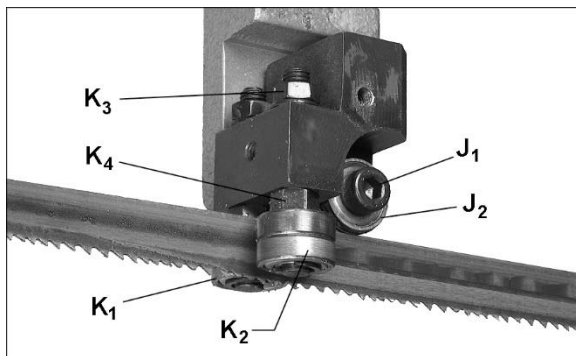

Figure 7-7: blade guide bearings

7.7 Blade tension and tracking

Refer to Figure 7-8.

7.7.1 Tension

1. Disconnect machine from power source.
2. Loosen movable blade guide arm and slide it away from the other arm as far as possible.
3. Turn blade tension handle (P, Figure 7-8) clockwise to tighten blade. Pluck the blade with your finger; a tensioned blade will emit a “twang” sound. As experience with the saw is gained, operator may develop a better feel for how tight to set a particular blade.

For precise measurement, use a blade tension gauge (not provided). Hard-back blades are generally tensioned at about 25,000 PSI (1757 kg/cm²); bi-metal blades at about 35,000 PSI (2460 kg/cm²).

4. Return blade guide arm to operating position.

Note: A new blade should be re-checked for proper tension after a few minutes' operation.

7.7.2 Tracking

⚠WARNING Blade tracking adjustment requires operating saw with wheel guards open. This adjustment must be completed by qualified persons only. Failure to comply may cause serious injury.

Blade tracking has been set by manufacturer. Adjustment is rarely required when blade is used properly and is correctly welded.

Tracking is set properly when blade runs without shifting on the wheels, and back of blade lightly touches shoulder of wheels.

If adjustment is required:

1. Confirm that blade tension is properly set.
2. Set belt position to slowest speed.
3. Raise bow to convenient position and open wheel guards.

⚠CAUTION While performing the following steps, keep blade from rubbing excessively on wheel shoulder. Excessive rubbing will damage wheel and/or blade.

4. Run saw and observe blade – it should run next to, but not tightly against, wheel shoulder.
5. If blade is not tracking properly, loosen either of two hex nuts (N₁, Figure 7-8).
6. Turn set screw (N₂) with hex wrench, while observing blade tracking on wheel. **NOTE:** This adjustment is sensitive; start with 1/4-turns on set screw and allow blade to respond to changes.

⚠WARNING Keep fingers clear of blade and wheel to avoid injury.

7. Test the setting by placing a six-inch length of paper between blade and wheel. The paper should not be cut as it passes between wheel shoulder and blade.
8. Turn set screw (N₂) a small amount. Repeat insertion of paper between the shoulder and the blade until paper is cut into two pieces.

NOTE: You may have to repeat the check with the paper several times before blade and shoulder cut the paper into two pieces. Do not hurry the adjustment. Patience and accuracy here will pay off with better, more accurate, quieter cutting and longer machine and blade life.

9. When paper is cut, back off set screw slightly. This assures that blade is not pushing excessively against wheel shoulder.
10. Once tracking is set, tighten hex nuts (N_1).

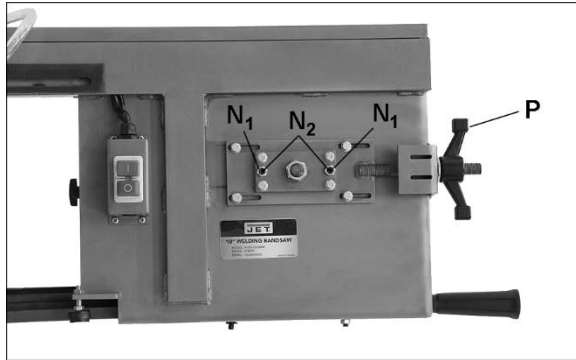

Figure 7-8: blade tension and tracking

7.8 Blade-to-table squareness

Refer to Figure 7-9.

The blade must be perpendicular to table when running between the bearing guides, to ensure a straight cut. This setting has been made by the manufacturer but should be confirmed by the operator.

1. Disconnect machine from power source.
2. Lower bow to horizontal position.
3. Place a machinist's square (not provided) on table and against blade surface. The square should lie flat against blade without a gap.
4. If a gap exists, slightly loosen socket head bolts (L, Figure 7-9) behind blade guide arms. Turn any of four set screws (M) as needed, until gap is eliminated between square and blade.
5. Retighten bolts (L) securely.
6. After making this adjustment, be sure to reinspect other blade adjustments as noted in this manual.

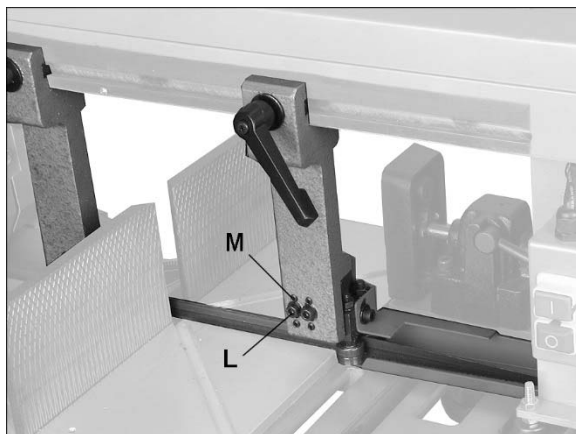

Figure 7-9: squareness adjustment

7.8.1 Test cut to verify adjustment

Test cuts can be used to determine whether or not the blade is accurately adjusted. Use 2-inch round bar stock to perform these test cuts, as follows:

1. With bar stock securely clamped in vise, make a cut through the bar stock. (See Figure 7-10.)
2. Mark the top of bar stock.
3. Move the bar stock about 1/4-inch past the blade so that you can begin a second cut.
4. Rotate the bar stock 180 degrees so the mark you made is now at bottom of cut.
5. Make a cut through the bar stock.
6. Use a micrometer to measure the thickness variation of the disk you have cut from the bar stock. Measure at top and bottom of disk.

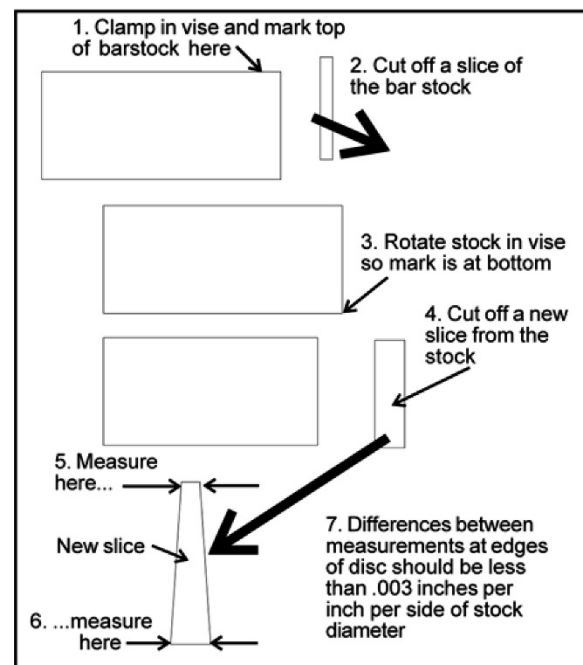

Figure 7-10

The saw blade can be considered correctly adjusted when the variation measure is no more than 0.012 inch across the face of the disk.

If you do not have a piece of 2-inch bar stock available for a test cut, use a larger diameter test piece rather than a smaller one. The maximum thickness variation on any test piece should be no more than 0.003 inch, per side, per inch of stock diameter.

7.9 Setting feed rate

Feed rate of blade into workpiece is important to band saw performance. Excessive pressure of blade against workpiece may cause stalling or blade breakage. In contrast, insufficient pressure rapidly dulls the blade.

The hydraulic cylinder resists bow movement in downward direction. It offers no resistance when bow is raised.

To increase feed rate, turn dial (R₁, Figure 7-11) counterclockwise. To decrease, turn clockwise.

To close hydraulic flow, turn lever (R₂) down, perpendicular to cylinder, as shown. To open hydraulic flow, turn lever (R₂) parallel to cylinder.

Feed rate is adjusted by operator until saw is operating efficiently, usually determined by observing chip formation. See *sect. 8.4, Evaluating cutting efficiency*.

CAUTION Do not push down on bow to increase feed pressure – allow cylinder to do the work.

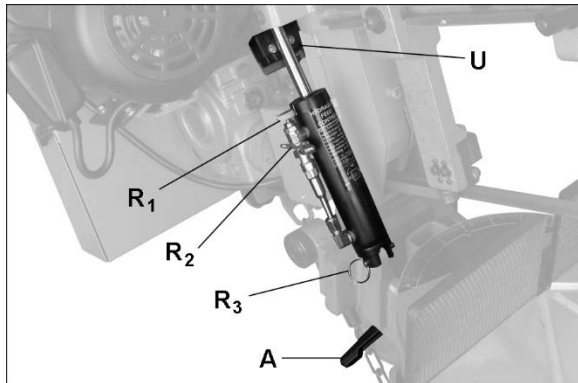

Figure 7-11: feed rate adjustment

7.10 Counterbalance spring

The counterbalance spring helps control amount of weight, or feed pressure, the bow puts on workpiece when hydraulic control valve is fully open. The hydraulic cylinder will not compensate for improper counterbalance. If spring is improperly set, one can expect poor performance, crooked cuts, tooth stripping, stalling, and/or blade running off wheels.

Spring tension has been set by the manufacturer, and should not require adjustment. If future problems arise, indicating improper counterbalance, adjust spring with knob (S, Figure 7-12).



Figure 7-12

A good indication of proper feed pressure is the color and shape of the cutting chips. If chips are thin or powdered, increase feed pressure. If chips are burned and heavy, decrease feed pressure. If they are still burned and heavy, reduce blade speed. Optimum feed pressure has been set when chips are curled, silvery, and warm.

7.11 Vertical bow position

1. Disconnect band saw from power source.
2. Position bow at 90-degrees (zero swivel).
3. Pull linch pin (R₃, Figure 7-11) out of cylinder, and raise bow to vertical position. Make sure swivel locking handle (A, Figure 7-11) does not obstruct bow positioning.
4. Install cutting platform (Figure 7-13). Push vise jaw against it, and clamp tightly.
5. Place a machinists' square on cutting platform and against *back edge* of blade to verify perpendicularity. If adjustment is needed, loosen nut and turn vertical stop screw (T, Figure 7-12). Tighten stop screw nut against bow to secure setting.

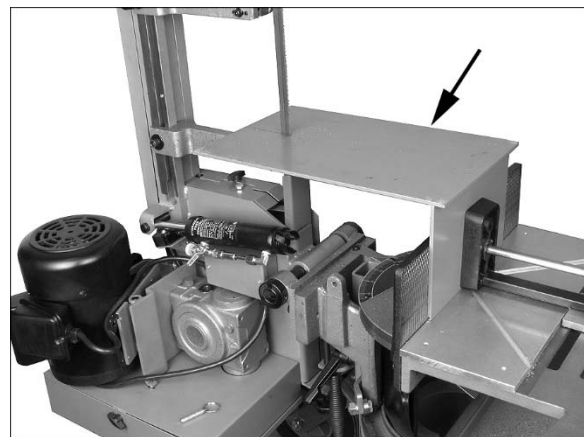

Figure 7-13: vertical cutting platform

7.12 Auto shut-off adjustment

The saw is properly adjusted when blade shuts off just after cut completion. This should occur when blade is about 1/8-inch below table surface. To adjust:

- If saw completes cut but blade continues moving, adjust limit switch bracket (U, Figure 7-11) downward.
- If blade stops before cut is complete, adjust limit switch bracket (U, Figure 7-11) upward.
- If blade stops descending and continues running without completing the cut, turn stop bolt down (Figure 7-14).

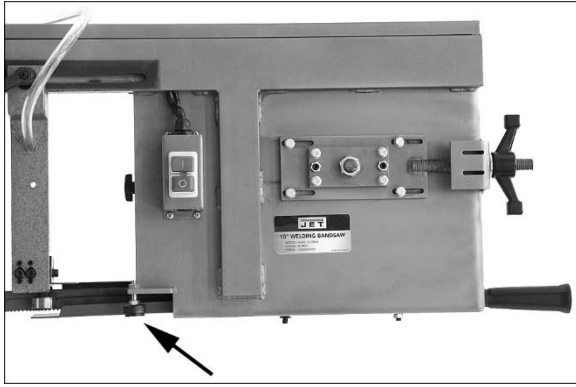

Figure 7-14: stop bolt adjustment

7.13 Vise positioning

The floating vise jaw can be moved before or behind blade. Loosen locking knob (V_1) and slide vise to position.

To clamp workpiece, push jaw close to workpiece using rod (V_2), then push top handle down to tighten.

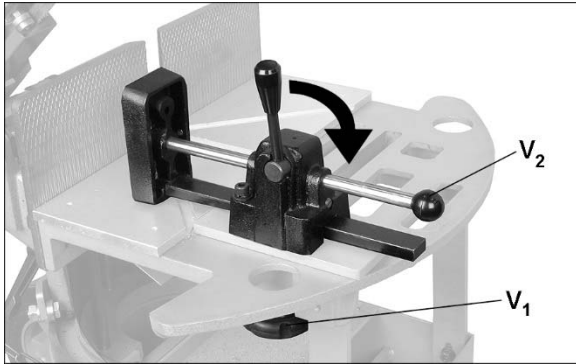

Figure 7-15: floating vise jaw

7.14 Work stop

The work stop is generally used when cutting multiple pieces to identical length. Position stop desired distance from blade and tighten set screw. Loosen collar (see A_2 , Figure 5-2) to slide work stop along lower rod. Retighten collar before operating.

8.0 Operation

8.1 Blade selection

The saw is provided with a blade that is adequate for a variety of cut-off jobs on a variety of common materials.

See Table 3 for recommended speeds for various materials. These selections, while appropriate for many shop cutting needs, do not encompass the wide variety of blades of special configuration (tooth pitch and set) and special alloys for cutting unusual or exotic materials.

Speed/FPM	Material
64	Tool Steel, Stainless Steel, Phosphor Bronze, Cast Iron, Malleable Iron
132	Mild Steel, Hard Brass, Bronze
247	Soft Brasses and Bronzes, Hard Aluminum, Plastics

Table 3

A coarse blade could be used for a solid steel bar but a finer tooth blade would be used on a thin-wall tube. In general, the blade choice is determined by the thickness of the material; the thinner the material, the finer the tooth pitch.

A minimum of three teeth should be on the work piece at all times for proper cutting. The blade and workpiece can be damaged if the teeth are so far apart that they straddle the workpiece.

For very high production on cutting of special materials, or to work hard-to-cut materials such as stainless steel, tool steel, or titanium, ask your industrial distributor for more specific blade recommendations. Also, the supplier who provides the workpiece material should be prepared to provide specific instructions regarding the best blade (and coolant or cutting fluid, if needed) for the material and shape supplied.

8.2 Blade break-in

New blades are very sharp and therefore have a tooth geometry which is easily damaged if a careful break-in procedure is not followed. Consult the blade manufacturer's literature for break-in of specific blades on specific materials. However, the following procedure will be adequate for break-in of JET-supplied blades on lower alloy ferrous materials.

1. Clamp a round section workpiece in the vise. The workpiece should be 2 inches or larger in diameter.
2. Set the saw on low speed. Start the cut with a very light feed rate (i.e. bow descent).
3. When the saw has completed 1/3 of the cut, increase feed rate slightly and allow saw to complete the cut.
4. Keep the same hydraulic cylinder setting and begin a second cut on the same or similar workpiece.
5. When blade has completed about 1/3 of cut, increase feed rate. Watch chip formation until cutting is at its most efficient rate and allow saw to complete the cut (see *sect. 8.4, Evaluating cutting efficiency*).
6. The blade is now ready for regular service.

8.3 General operating procedure

IMPORTANT: When cutting magnesium, never use soluble oils or emulsions (oil-water mix) as water will greatly intensify any accidental magnesium chip fire. See your industrial coolant supplier for specific coolant recommendations when cutting such material.

1. Give machine an overall inspection. Verify that all guards, covers, etc. are in place and in working order, the blade is tensioned properly and tooth direction matches arrow on bow. Check that blade guides are set correctly.
2. Position bow for desired angle of cut.
3. Adjust movable blade guide to minimize exposed blade area.
4. Raise bow until it will clear workpiece by a few inches, and secure in position by closing cylinder valve.

CAUTION Always secure bow in raised position before loading material. Never start a cut with blade contacting workpiece.

5. Position workpiece in vise and clamp it securely. Workpiece should be fitted directly between the jaws without adding other objects. When workpiece is profiled section, flat piece or special shape, refer to examples in Figure 8-1 for proper clamping positions.

If the thickness of profile section is very thin, a piece which duplicates the profile should be fitted inside the workpiece itself, to prevent workpiece being crushed between the jaws.

WARNING Do not load/unload material from vise while machine is running. Never hold workpiece by hand when cutting; workpiece must be firmly secured in vise. Do not reach into cutting area during cutting operations.

6. Set suitable feed rate on cylinder dial.
7. Turn on saw and allow to reach full speed. Start coolant flow (if applicable).
8. Open valve on hydraulic cylinder to allow bow to descend in gradual and controlled manner.
9. Stop screw must turn off saw at completion of cut.

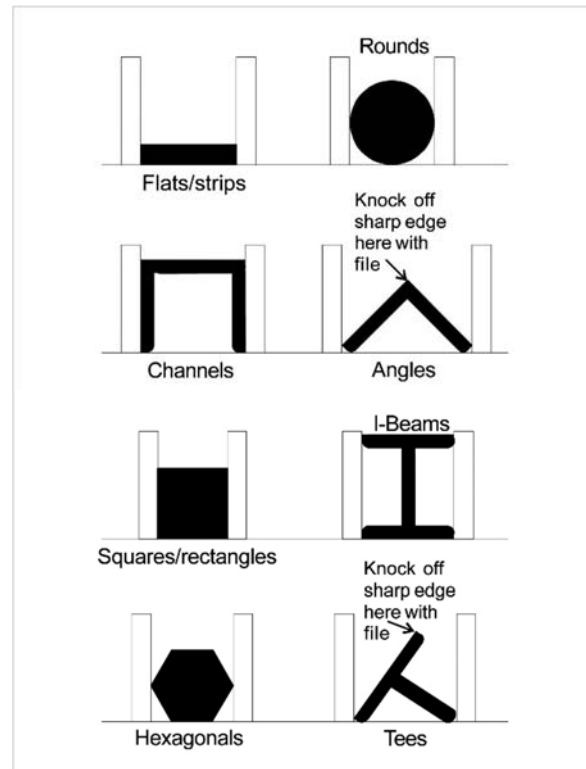

Figure 8-1: clamping positions

8.4 Evaluating cutting efficiency

Is the blade cutting efficiently? The best way to determine this is to observe the chips formed by the cutting blade.

If chip formation is powdery, then the feed rate is much too light, or the blade is dull.

If chips formed are curled, but colored — that is, either blue or straw-colored from heat generated during the cut — then the feed rate is too high.

If chips are slightly curled and are not colored by heat — the blade is sufficiently sharp and is cutting at its most efficient rate.

9.0 User-maintenance

⚠WARNING Always disconnect power to machine before performing maintenance. Failure to do this may result in serious personal injury.

Keep all surfaces clean and free of rust, slag, chips, and coolant build-up.

Clear away metal particles with small paint brush or parts cleaning brush. Do not use compressed air, as it may force chips into the guide bearings and other critical areas of saw.

Clean chip screen as needed.

Make frequent inspections of motor fan, and blow out (with low pressure air hose) or vacuum any accumulation of foreign material to maintain normal motor ventilation.

Wipe saw down with a clean, dry cloth, and oil all unpainted surfaces with light machine oil.

Check guide bearings frequently to make sure that they are properly adjusted and turning freely, and are free from metal particles.

Periodically inspect drive belt for wear or fraying. Replace if needed.

To prevent corrosion of machined surfaces when a soluble oil is used as coolant, pay particular attention to wiping dry the surfaces where fluid accumulates and does not evaporate quickly, such as between table and vise.

Place a thin coat of oil on table surface on which vise jaw slides.

If the power cord is worn, cut, or damaged in any way, have it replaced immediately.

9.1 Lubrication

All ball bearings are permanently lubricated and sealed. They require no further lubrication.

Drain and refill gear box oil after first 50 hours of operation. Thereafter, change every six months. Use an industrial gear oil.

To change gear box oil:

1. Disconnect machine from power source.
2. Place bow in horizontal position and allow a few moments for oil to settle.
3. Remove drain plug (A, Figure 9-1) and drain oil into suitable container. Reinstall drain plug.
4. Remove fill plug (B) and fill gear box until oil is level with mid-point of sight window (C). Do not overfill.
5. Install fill plug.

Periodically inspect sight window and maintain fluid level.

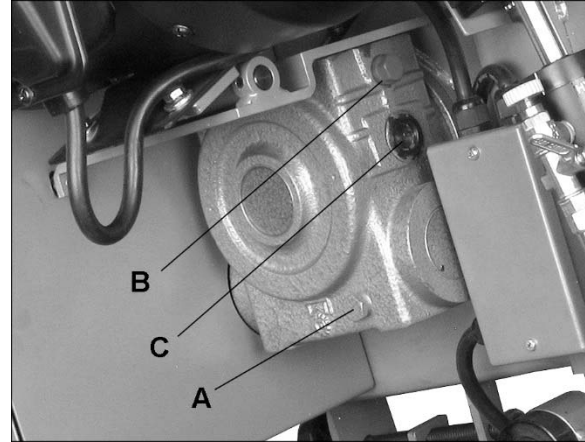

Figure 9-1: gearbox

9.2 Coolant level (HVBS-10DMW-C)

Maintain coolant level. Low coolant level can cause foaming and high blade temperatures. Replace dirty coolant; dirty or weak coolant can clog the pump, cause crooked cuts, a low cutting rate and/or permanent blade damage. Follow coolant manufacturer's instructions for proper use and disposal.

9.3 Additional servicing

Any additional servicing on the band saw should be performed by an authorized service representative.

10.0 Troubleshooting HVBS-DM series Band Saws

Symptom	Possible Cause	Correction*
Excessive blade breakage	Material loose in vise.	Clamp work securely.
	Incorrect speed or feed.	Check machinery handbook for speed/ feed appropriate for material being cut.
	Teeth too coarse for material.	Check machinery handbook for recommended blade type.
	Incorrect blade tension.	Adjust blade tension to the point where the blade just does not slip on the wheel.
	Saw blade in contact with workpiece before saw is started.	Start motor before placing blade on workpiece.
	Blade rubs on wheel shoulder.	Adjust blade tracking.
	Misaligned guides.	Adjust guides.
	Cracking at weld.	Longer annealing cycle.
Premature blade dulling	Blade teeth too coarse.	Use a finer tooth blade.
	Blade speed too high.	Try a lower blade speed.
	Inadequate feed pressure.	Decrease spring tension.
	Hard spots in workpiece or scale on/in workpiece.	Increase feed pressure (hard spots). Reduce speed, increase feed pressure (scale).
	Work hardening of material (especially stainless steel).	Increase feed pressure by reducing spring tension.
	Insufficient blade tension.	Increase tension to proper level.
	Operating saw without pressure on workpiece.	Do not run blade at idle in/on material.
Bad cuts (out-of-square)	Workpiece not square with blade.	Adjust vise so it is square with the blade. (Always clamp work tightly in vise.)
	Feed pressure too fast.	Decrease pressure.
	Guide bearings not adjusted properly.	Adjust guide bearing clearance to 0.001 inch (0.002 inch maximum).
	Inadequate blade tension.	Gradually increase blade tension.
	Span between the two blade guides too wide.	Move blade guide bar closer to work.
	Dull blade.	Replace blade.
	Incorrect blade speed.	Check blade speed/pulley position.
	Blade guide assembly is loose.	Tighten blade guide assembly.
	Blade guide bearing assembly loose.	Tighten blade guide bearing assembly.
	Blade track too far away from wheel shoulders.	Adjust blade tracking.
	Guide bearing worn.	Replace worn bearing.
Bad cuts (rough)	Blade speed too high for feed pressure.	Reduce blade speed and feed pressure.
	Blade too coarse.	Replace with finer blade.
Blade is twisting	Blade is binding in the cut.	Decrease feed pressure.
	Blade tension too high.	Decrease tension on blade.

Symptom	Possible Cause	Correction*
Unusual wear on side or back of blade	Blade guides worn	Replace blade guides.
	Blade guide bearings not adjusted.	Adjust blade guide bearings.
	Blade guide bearing bracket is loose.	Tighten blade guide bearing bracket.
Teeth missing/ripped from blade	Blade tooth pitch too coarse for workpiece.	Use blade with finer tooth pitch.
	Feed too slow; feed too fast.	Increase feed pressure and/or blade speed.
	Workpiece vibrating.	Clamp workpiece securely.
	Gullets loading up with chips.	Use blade with coarse tooth pitch; reduce feed pressure. Brush blade to remove chips.
Motor running too hot	Blade tension too high.	Reduce tension on blade.
	Drive belt tension too high.	Reduce tension on drive belt.
	Blade too coarse for workpiece (especially with tubular stock).	Use blade with fine tooth pitch.
	Blade too fine for workpiece (especially with heavier, soft material).	Use blade with coarse tooth pitch.
	Insufficient gearbox lubrication	Check gearbox oil.
No coolant flow	Pump motor is burned out.	Replace pump.
	Screen/filter on pump is clogged.	Clean screen/filter.
	Impeller is loose.	Tighten impeller.
	Coolant level too low.	Add coolant to reservoir.
Excessive noise or vibration	Belt is too tight.	Reset belt tension.

***Warning:** Some corrections may require a qualified electrician.

11.0 Replacement Parts

Replacement parts are listed on the following pages. To order parts or reach our service department, call 1-800-274-6848 Monday through Friday, 8:00 a.m. to 5:00 p.m. CST. Having the Model Number and Serial Number of your machine available when you call will allow us to serve you quickly and accurately.

Non-proprietary parts, such as fasteners, can be found at local hardware stores, or may be ordered from JET. Some parts are shown for reference only, and may not be available individually.

11.1.1 HVBS-8-DMW Bow Assembly – Exploded View

Figure 11-1

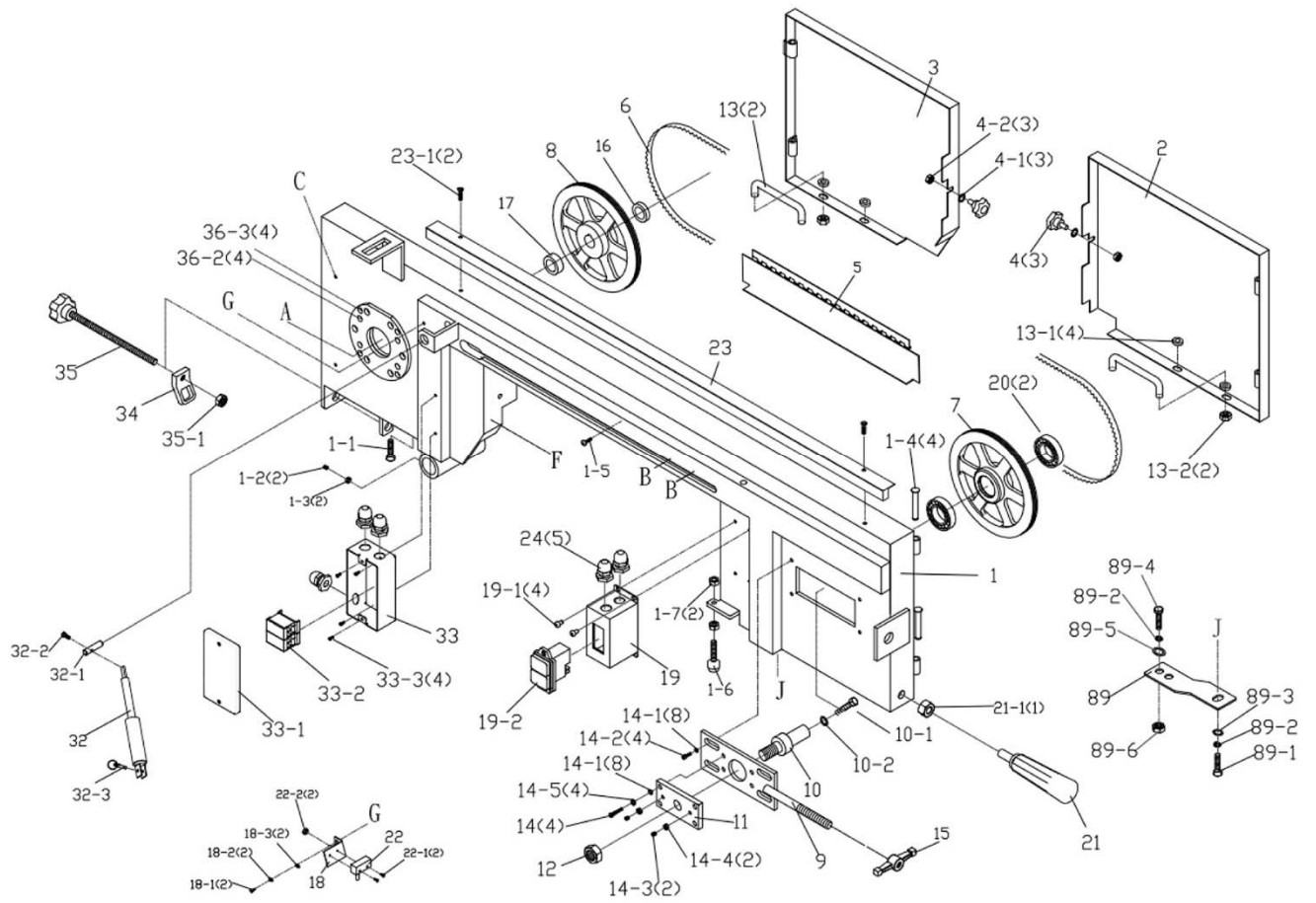

11.1.2 HVBS-8-DMW Table Assembly – Exploded View

Figure 11-2

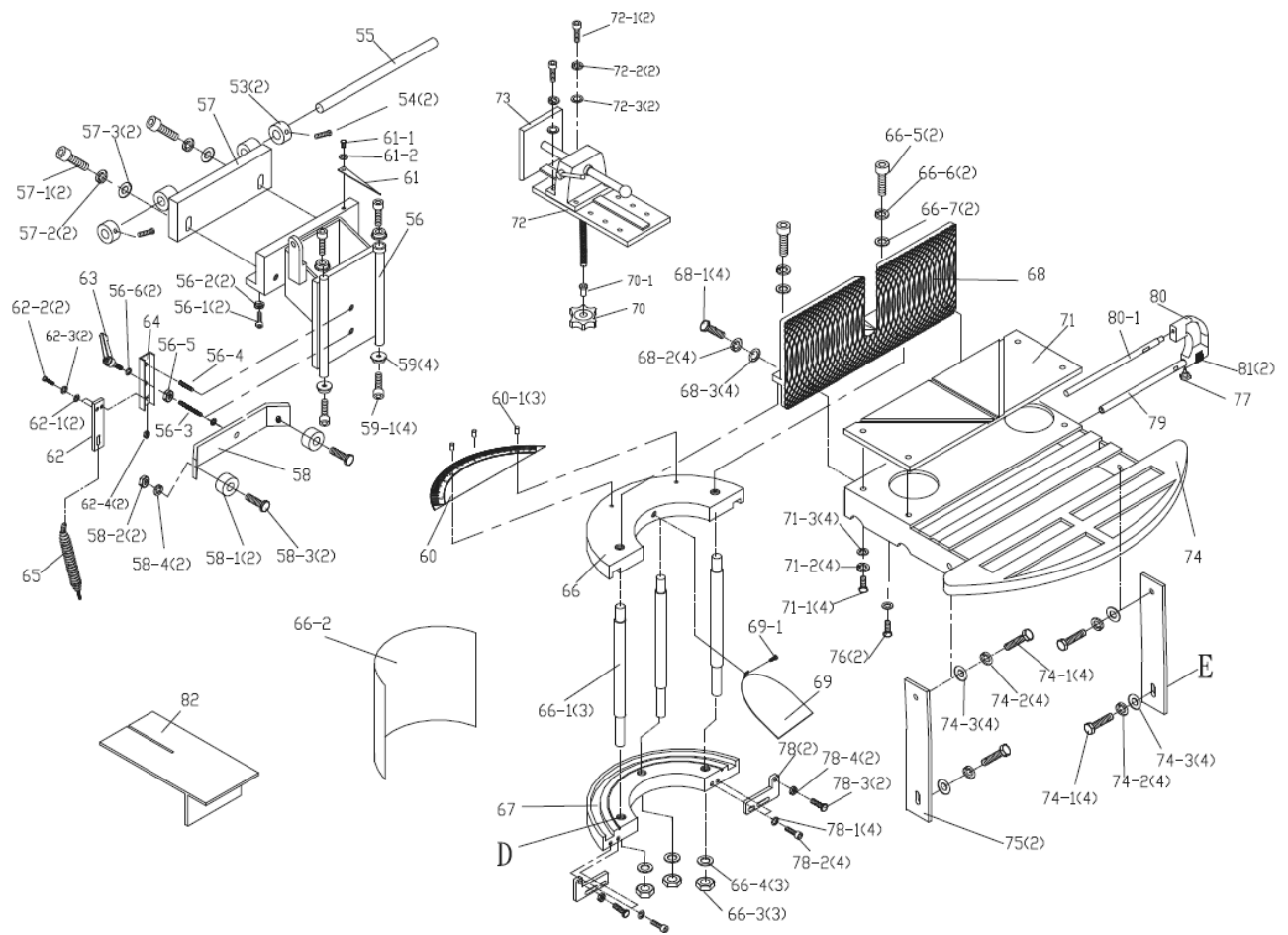

11.1.3 HVBS-8-DMW Motor and Support Arm Assembly – Exploded View

Figure 11-3

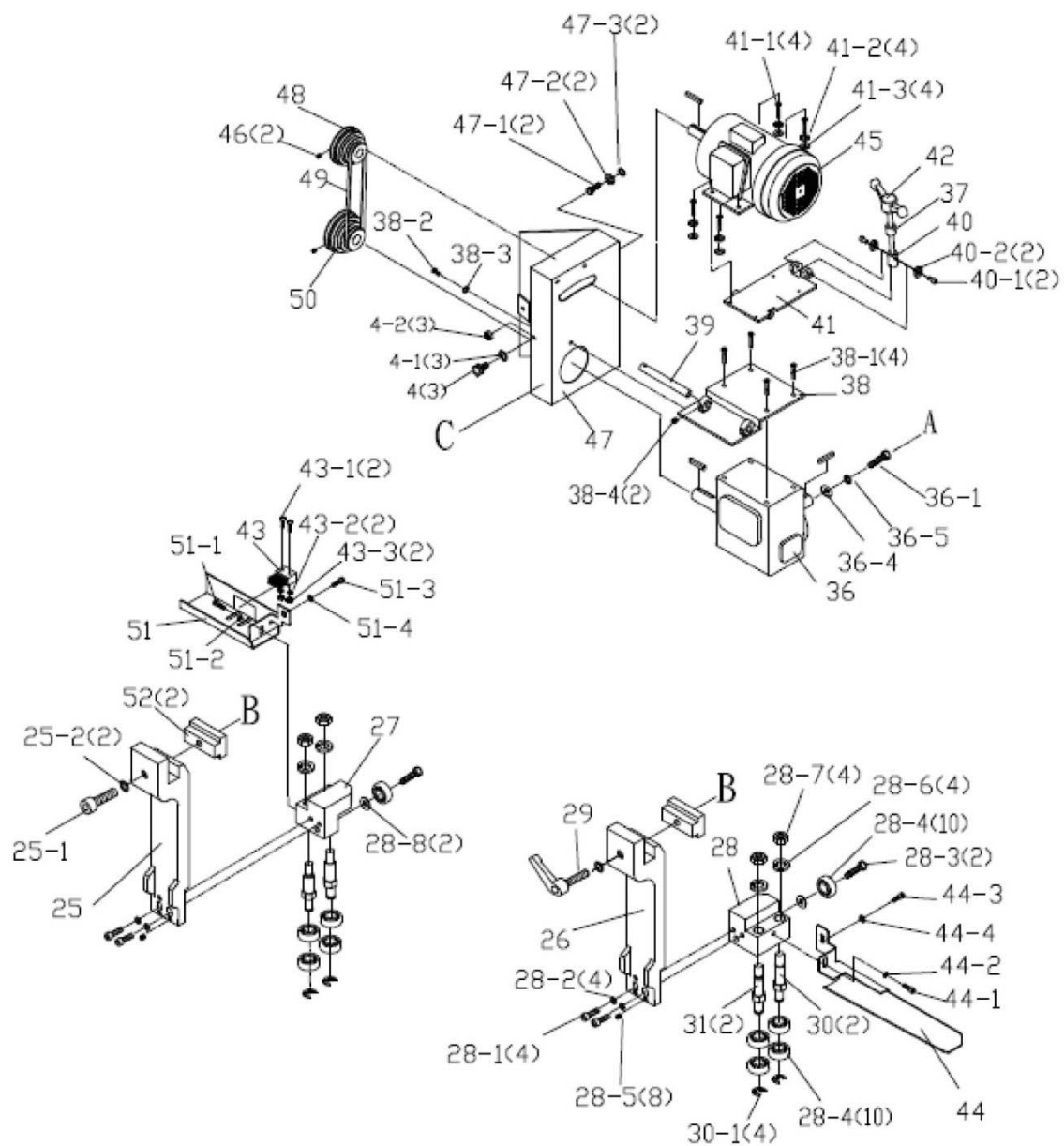

11.1.4 HVBS-8-DMW Vise and Table Assembly – Exploded View

Figure 11-4

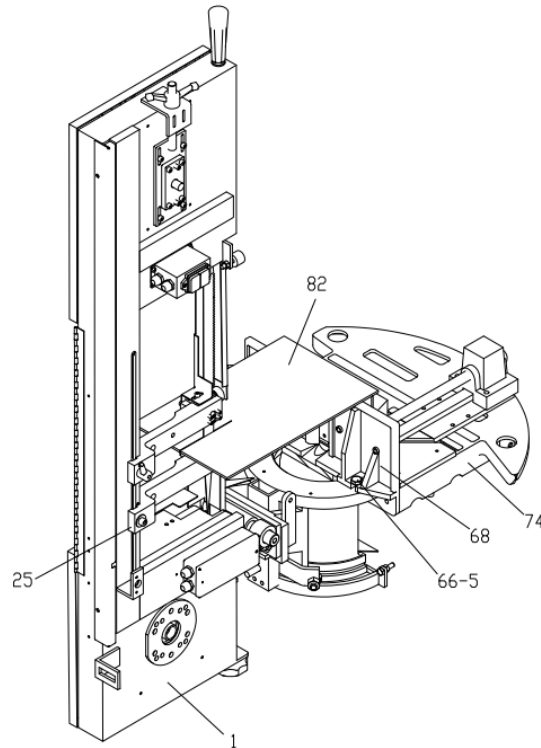

11.1.5 HVBS-8-DMW Base Assembly – Exploded View

Figure 11-5

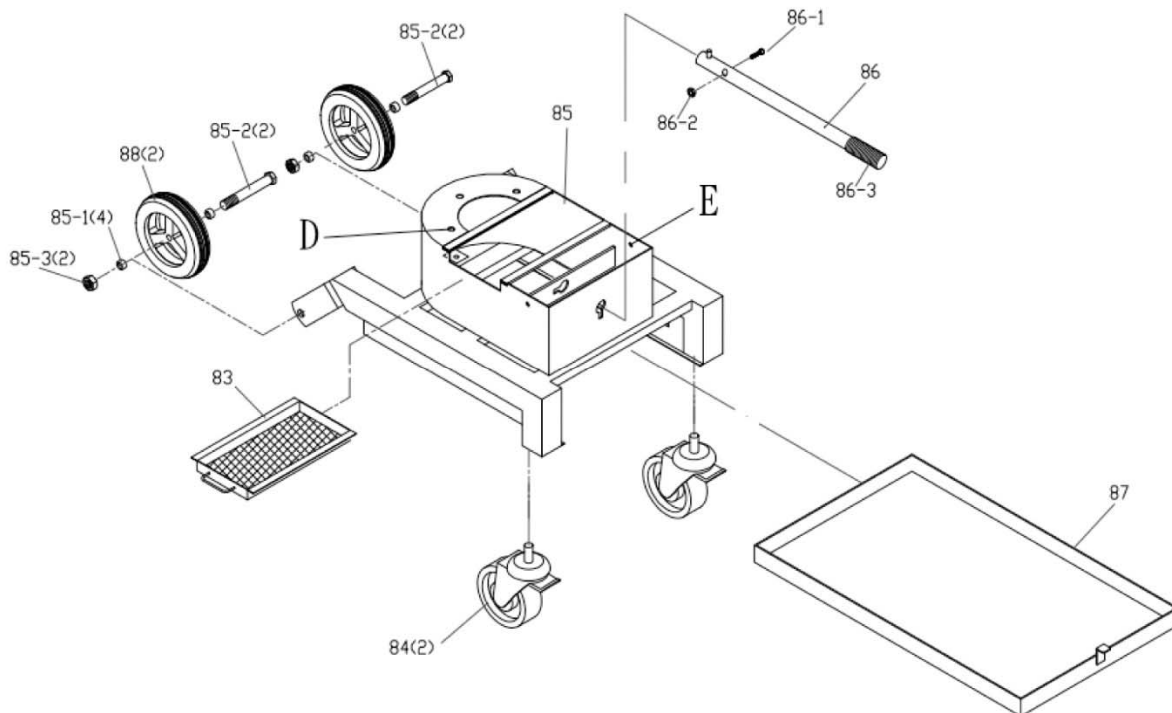

11.1.6 HVBS-8-DMW – Parts List

Index No	Part No	Description	Size	Qty
1	HVBS-8-DMW-1	Saw Bow		1
1-1	TS-1490091	Hex Cap Bolt	M8-1.25x45L	1
1-2	TS-1524051	Set Screw	M8-1.25x20L	2
1-3	TS-2331081	Hex Nut	M8-1.25	2
1-4	HVBS-8-DMW-1-4	Hinge Pin		4
1-5	F001214	Phillips Pan Hd Machine Screw	M6-1.0x8L	1
1-6	HVBS-8-DMW-1-6	Screw		1
1-7	TS-0640081	Hex Nut	5/16"-18NC	2
2	HVBS-8-DMW-2	Idler Wheel Guard		1
3	HVBS-8-DMW-3	Drive Wheel Guard		1
4	HVBS-8-DMW-4	Handle		3
4-1	TS-1550041	Flat Washer	6mm	3
4-2	TS-0640071	Hex Nut	1/4"-20NC	3
5	HVBS-8-DMW-5	Upper Blade Guard		1
6	HVBS-8-DMW-6	Saw Blade	6/10T, 3/4 x 0.035 x 103"L, (19x0.9x2616 mm)	1
7	HVBS-8-DMW-7	Idler Wheel		1
8	HVBS-8-DMW-8	Drive Wheel		1
9	HVBS-8-DMW-9	Tension Slider		1
10	HVBS-8-DMW-10	Idle Wheel Shaft		1
10-1	TS-1490021	Hex Cap Bolt	M8-1.25x15L	1
10-2	TS-1550061	Flat Washer	8mm	1
11	HVBS-8-DMW-11	Slider Cover		1
12	TS-2311161	Hex Nut	M16-2.0	1
13	HVBS-8-DMW-13	Guard Prop		2
13-1	HVBS-8-DMW-13-1	Grommet		4
13-2	TS-1540061	Hex Nut	M8-1.25	2
14	TS-1482061	Hex Cap Bolt	M6-1.0x30L	4
14-1	TS-1550041	Flat Washer	6mm	8
14-2	TS-1482041	Hex Cap Bolt	M6-1.0x20L	4
14-3	TS-1524051	Set Screw	M8-1.25x20L	2
14-4	TS-1540061	Hex Nut	M8-1.25	2
14-5	TS-2361061	Lock Washer	M6	4
15	HVBS-8-DMW-15	Handle		1
16	HVBS-8-DMW-16	Reducer Adapter		1
17	HVBS-8-DMW-17	Spacer Ring		1
18	HVBS-8-DMW-18	Bracket		1
18-1	F001208	Philips Pan Hd Machine Screw	M5-0.8x8L	2
18-2	TS-2361051	Lock Washer	M5	2
18-3	TS-1550031	Flat Washer	5mm	2
19	HVBS-8-DMW-19	Switch Box		1
19-1	HVBS-8-DMW-19-1	Philips Pan Hd Machine Screw	M5-0.8x8L	4
19-2	HVBS-8-DMW-19-2	Pushbutton Assembly		1
20	BB-R10ZZ	Bearing	R10ZZ	2
21	HVBS-8-DMW-21	Handle		1
21-1	TS-2311121	Hex Nut	M12-1.75	1
22	HVBS-8-DMW-22	Limit Switch		1
22-1	HVBS-8-DMW-22-1	Philips Pan Hd Machine Screw	M4-0.7x25L	2
22-2	TS-1540021	Hex Nut	M4-0.7	2
23	HVBS-8-DMW-23	Cable Cover		1
23-1	HVBS-8-DMW-23-1	Philips Pan Hd Machine Screw	M6-1.0x10L	2
24	HVBS-8-DMW-24	Strain Relief	PG-9	5
25	HVBS-8-DMW-25	Fixed Guide Arm		1
25-1	TS-0209061	Hex Socket Cap Screw	3/8"-16NCx1-1/4"L	1
25-2	TS-0680041	Flat Washer	3/8"	2
26	HVBS-8-DMW-26	Movable Guide Arm		1
27	HVBS-8-DMW-27	Fixed Guide Block		1
28	HVBS-8-DMW-28	Movable Guide Block		1
28-1	TS-1503061	Hex Socket Cap Screw	M6-1.0x25L	4
28-2	TS-1550041	Flat Washer	6mm	4
28-3	TS-1504041	Hex Socket Cap Screw	M8-1.25x20L	2

Index No	Part No	Description	Size	Qty
28-4	BB-608ZZ	Bearing	608ZZ	10
28-5	TS-1523051	Set Screw	M6-1.0x16L	8
28-6	TS-2361081	Lock Washer	M8	4
28-7	TS-1540061	Hex Nut	M8	4
28-8	TS-1550061	Flat Washer	8mm	2
29	HVBS-8-DMW-29	Handle	TRT80 3/8x30L	1
30	HVBS-8-DMW-30	Bearing Shaft		2
30-1	PB85-115	E-clip	E7	4
31	HVBS-8-DMW-31	Eccentric Shaft		2
32	HVBS-8-DMW-32	Cylinder		1
32-1	HVBS-8-DMW-32-1	Cylinder Pin		1
32-2	HVBS-8-DMW-32-2	Screw	M8-1.25x25L	1
32-3	HVBS-8-DMW-32-3	Linch Pin		1
33	HVBS-8-DMW-33	Junction Box		1
33-1	HVBS-8-DMW-33-1	Box Cover		1
33-2	HVBS-8-DMW-33-2	Terminal Block		2
33-3	HVBS-8-DMW-33-3	Philips Pan Hd Machine Screw	M4-0.7x8L	4
34	HVBS-8-DMW-34	Spring Holder		1
35	HVBS-8-DMW-35	Bolt		1
35-1	TS-0561051	Hex Nut	1/2"-13	1
36	HVBS-8-DMW-36	Gearbox		1
36-1	TS-0081031	Hex Cap Bolt	5/16"-18NCx3/4L	1
36-2	TS-1524051	Set Screw	M8-1.25x20L	4
36-3	TS-0208041	Hex Socket Cap Screw	5/16"-18NCx3/4"L	4
36-4	TS-0680031	Flat Washer	5/16"	1
37	LF20-304	Key, Double Rd Hd	5x5x25mmL	1
37-1	S0400545	Key, Double Rd Hd	5x5x45mmL	1
38	HVBS-8-DMW-38-1	Motor Tilt Plate		1
38-1	TS-1335052	Philips Pan Hd Machine Screw	5/16"-18NCx3/4L	4
38-2	F009919	Button Head Socket Screw	M5-0.8x6L	1
38-3	TS-1540031	Hex Nut	M5	1
38-4	HVBS-8-DMW-38-4	Set Screw	M6-1.0x8L	2
39	HVBS-8-DMW-39	Shaft		1
40	HVBS-8-DMW-40	Screw		1
40-1	TS-1503031	Hex Socket Cap Screw	M6-1.0x12L	2
41	HVBS-8-DMW-41	Motor Mount		1
41-1	TS-1482021	Hex Cap Bolt	M6-1.0x12L	4
41-2	TS-2361061	Lock Washer	M6	4
41-3	TS-1550041	Flat Washer	6mm	4
42	HVBS-8-DMW-42	Handle		1
42-1	HVBS-8-DMW-42-1	Belt Tension Unit		1
43	HVBS-8-DMW-43	Brush		1
43-1	F001187	Philips Pan Hd Machine Screw	M4x25	2
43-2	TS-1550021	Flat Washer	M4	2
43-3	TS-1540021	Hex Nut	M4	2
44	HVBS-8-DMW-44	Blade guard		1
44-1	TS-1503021	Hex Socket Cap Screw	M6-1.0x10L	1
44-2	HVBS-8-DMW-44-2	Flat Washer	6mm	1
44-3	TS-1503021	Hex Socket Cap Screw	M6-1.0x10L	1
44-4	TS-1550041	Flat Washer	6mm	1
45	HVBS-8-DMW-45	Motor	3/4HP 1PH	1
	HVBS-8-DMW-45SC	Start Capacitor	300MFD 125VAC	1
	HVBS-8-DMW-45JB	Junction Box		1
	HVBS-8-DMW-45JBC	Junction Box Cover		1
	HVBS-8-DMW-45MF	Motor Fan		1
	HVBS-8-DMW-45MFC	Motor Fan Cover		1
46	992068	Key, Double Rd Hd	5x5x40 mm	1
47	HVBS-8-DMW-47	Pulley Box		1
47-1	HVBS-8-DMW-47-1	Pulley Box Cover		1
47-2	TS-1482021	Hex Cap Bolt	M6-1.0x12L	2
47-3	TS-2361061	Lock Washer	M6	2
47-4	TS-1550041	Flat Washer	6mm	2

Index No	Part No	Description	Size	Qty
48	HVBS-8-DMW-48	Motor Pulley		1
49	VB-A27	V-Belt	A27	1
50	HVBS-8-DMW-50	Gearbox Pulley		1
51	HVBS-8-DMW-51	Blade Guard		1
51-1	TS-1503021	Hex Socket Cap Screw	M6-1.0x10L	1
51-2	TS-1550041	Flat Washer	6x13x1.5 mm	1
51-3	TS-1503021	Hex Socket Cap Screw	M6-1.0x10	1
51-4	HVBS-8-DMW-51-4	Flat Washer	6x16x1.5 mm	1
52	HVBS-8-DMW-52	T-Block		2
53	HVBS-8-DMW-53	Collar		2
54	TS-1524011	Set Screw	M8-1.25x8L	2
55	HVBS-8-DMW-55	Bow Bearing Shaft		1
56	HVBS-8-DMW-56	Bracket		1
56-1	TS-1503061	Hex Socket Cap Screw	M6-1.0x25L	2
56-2	TS-2311061	Hex Nut	M6	2
56-3	HVBS-8-DMW-56-3	Threaded rod	M12x17.5x70L	1
56-4	HVBS-8-DMW-56-4	Threaded rod	M12X17.5x62L	1
56-5	TS-1540081	Hex Nut	M12-1.75	1
56-6	TS-2360121	Flat Washer	12mm	2
57	HVBS-8-DMW-57	Shaft Seat		1
57-1	F005452	Hex Socket Cap Screw	M12-1.75x30L	2
57-2	TS-2361121	Lock Washer	M12	2
57-3	TS-2360121	Flat Washer	12mm	2
58	HVBS-8-DMW-58	Plate		1
58-1	BB-6001ZZ	Bearing	6001ZZ	2
58-2	TS-1540081	Hex Nut	M12	2
58-3	TS-1492021	Hex Cap Bolt	M12-1.75x30L	2
58-4	TS-2361121	Lock Washer	M12	2
59	HVBS-8-DMW-59	Special Washer		4
59-1	TS-1504041	Hex Socket Cap Screw	M8-1.25x20L	4
60	HVBS-8-DMW-60	Angle Scale		1
60-1	F009919	Button Head Socket Screw	M5-1.0x6L	3
61	HVBS-8-DMW-61	Indicator		1
61-1	F009920	Button Head Socket Screw	M6-1.0x6L	1
61-2	TS-1550041	Flat Washer	6mm	1
62	HVBS-8-DMW-62	Support		1
62-1	TS-1550061	Flat Washer	8mm	2
62-2	TS-1504051	Hex Socket Cap Screw	M8-1.25x25L	2
62-3	TS-2361081	Lock Washer	M8	2
62-4	TS-1540061	Hex Nut	M8-1.25	2
63	HVBS-8-DMW-63	Handle	TRT100 M12	1
64	HVBS-8-DMW-64	Support Plate		1
65	HVBS-8-DMW-65	Tension Spring		1
66	HVBS-8-DMW-66	Upper Swivel Guide		1
66-1	HVBS-8-DMW-66-1	Support Rod		3
66-2	HVBS-8-DMW-66-2	Guide Cover		1
66-3	TS-1540081	Hex Nut	M12-1.75	3
66-4	TS-2360121	Flat Washer	12mm	3
66-5	TS-1504091	Hex Socket Cap Screw	M8-1.25x45L	2
66-6	TS-2361081	Lock Washer	M8	2
66-7	TS-1550061	Flat Washer	8mm	2
67	HVBS-8-DMW-67	Lower Swivel Guide		1
68	HVBS-8-DMW-68	Fixed Vise Jaw		1
68-1	TS-1504051	Hex Socket Cap Screw	M8-1.25x25L	4
68-2	TS-2361081	Lock Washer	M8	4
68-3	TS-1550061	Flat Washer	8mm	4
69	HVBS-8-DMW-69	Chip Deflector		1
69-1	TS-2246102	Button Head Socket Screw	M6-1.0x10L	1
70	HVBS-8-DMW-70	Vise Lock Knob		1
70-1	HVBS-8-DMW-70-1	Spacer		1
71	HVBS-8-DMW-71	Aluminum Miter Plate		1
71-1	TS-1503051	Hex Socket Cap Screw	M6-1.0x20L	4

Index No	Part No	Description	Size	Qty
71-2	TS-2361061	Lock Washer	M6	4
71-3	HVBS-8-DMW-71-3	Flat Washer	6x16x2 mm	4
72	HVBS-8-DMW-72	Movable Jaw Mount		1
72-1	TS-1504091	Hex Socket Cap Screw	M8-1.25x45L	2
72-2	TS-2361081	Lock Washer	M8	2
72-3	TS-1550061	Flat Washer	8mm	2
73	HVBS-8-DMW-73	Movable Jaw Assembly		1
74	HVBS-8-DMW-74	Bed		1
74-1	TS-1504041	Hex Socket Cap Screw	M8-1.25x20L	4
74-2	TS-2361081	Lock Washer	M8	4
74-3	TS-1550061	Flat Washer	8mm	4
75	HVBS-8-DMW-75	Bed Support		2
76	TS-1490041	Hex Cap Bolt	M8-1.25x25L	2
77	HVBS712-14	Plastic Knob		1
78	HVBS-8-DMW-78	45-Degree Plate		2
78-1	TS-1550041	Flat Washer	6mm	4
78-2	TS-1503051	Hex Socket Cap Screw	M6-1.0x20L	4
78-3	TS-1490061	Hex Cap Bolt	M8-1.25x35L	2
78-4	TS-1540061	Hex Nut	M8	2
79	HVBS712-17	Lower Work Stop Rod		1
80	HVBS712-15	Work Stop		1
80-1	HVBS-8-DMW-80-1	Upper Work Stop Rod		1
81	HVBS712-13	Threaded Collar		1
82	HVBS-8-DMW-82	Vertical Cutting Platform		1
83	HVBS-8-DMW-83	Chip Screen		1
84	HVBS-8-DMW-84	Swivel Caster	411 PU	2
85	HVBS-8-DMW-85	Carriage		1
85-1	HVBS-8-DMW-85-1	Spacer		4
85-2	HVBS-8-DMW-85-2	Axle Bolt	5/8x5"	2
85-3	TS-0561071	Hex Nut	5/8"-11	2
86	HVBS-8-DMW-86	Handle		1
86-1	TS-1481081	Hex Cap Bolt	M5-0.8x35L	1
86-2	TS-1540031	Hex Nut	M5-0.8	1
86-3	HVBS-8-DMW-86-3	Grip		1
87	HVBS-8-DMW-87	Chip Drawer		1
88	HVBS-8-DMW-88	Wheel		2
89	HVBS-8-DMW-89	Holder		1
89-1	F012620	Hex Cap Bolt	M8-1.25x8L	2
89-2	TS-2361081	Lock Washer	M8	2
89-3	TS-1550061	Flat Washer	8mm	1
89-4	TS-1490051	Hex Cap Bolt	M8-1.25x30L	1
89-5	TS-0680041	Flat Washer	3/8"	1
89-6	TS-1540061	Hex Nut	M8-1.25	1
	JET-138	JET Logo (not shown)	138x57mm	1
	LM000268	ID Label, HVBS-8DMW (not shown)		1
	LM000269	Label, Blade Speeds (not shown)		1
	LM000271	Warning Label (not shown)		1

11.2.1 HVBS-10-DMW/DMWC Bow Assembly – Exploded View

Figure 11-6

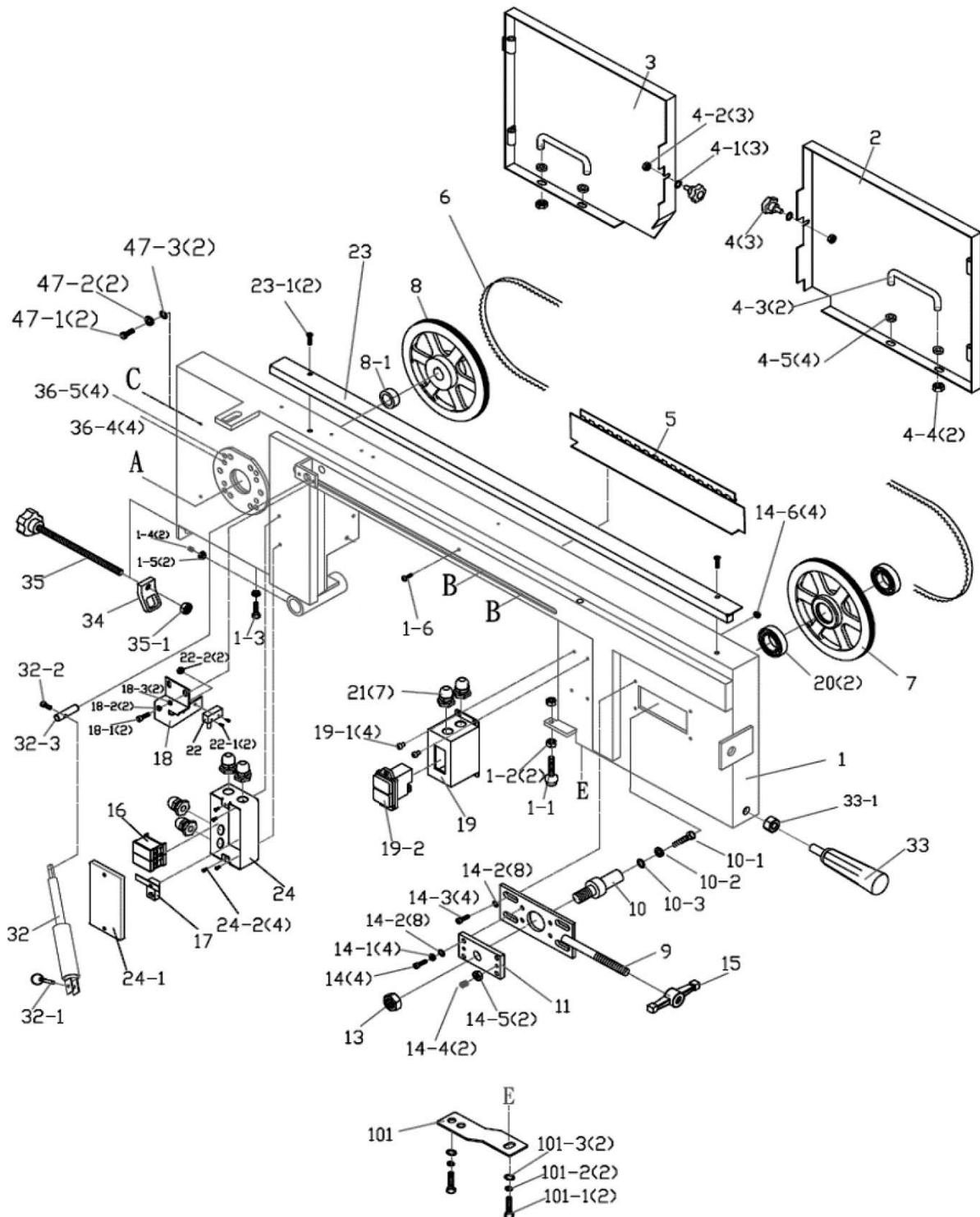

11.2.2 HVBS-10-DMW/DMWC Table Assembly – Exploded View

Figure 11-7

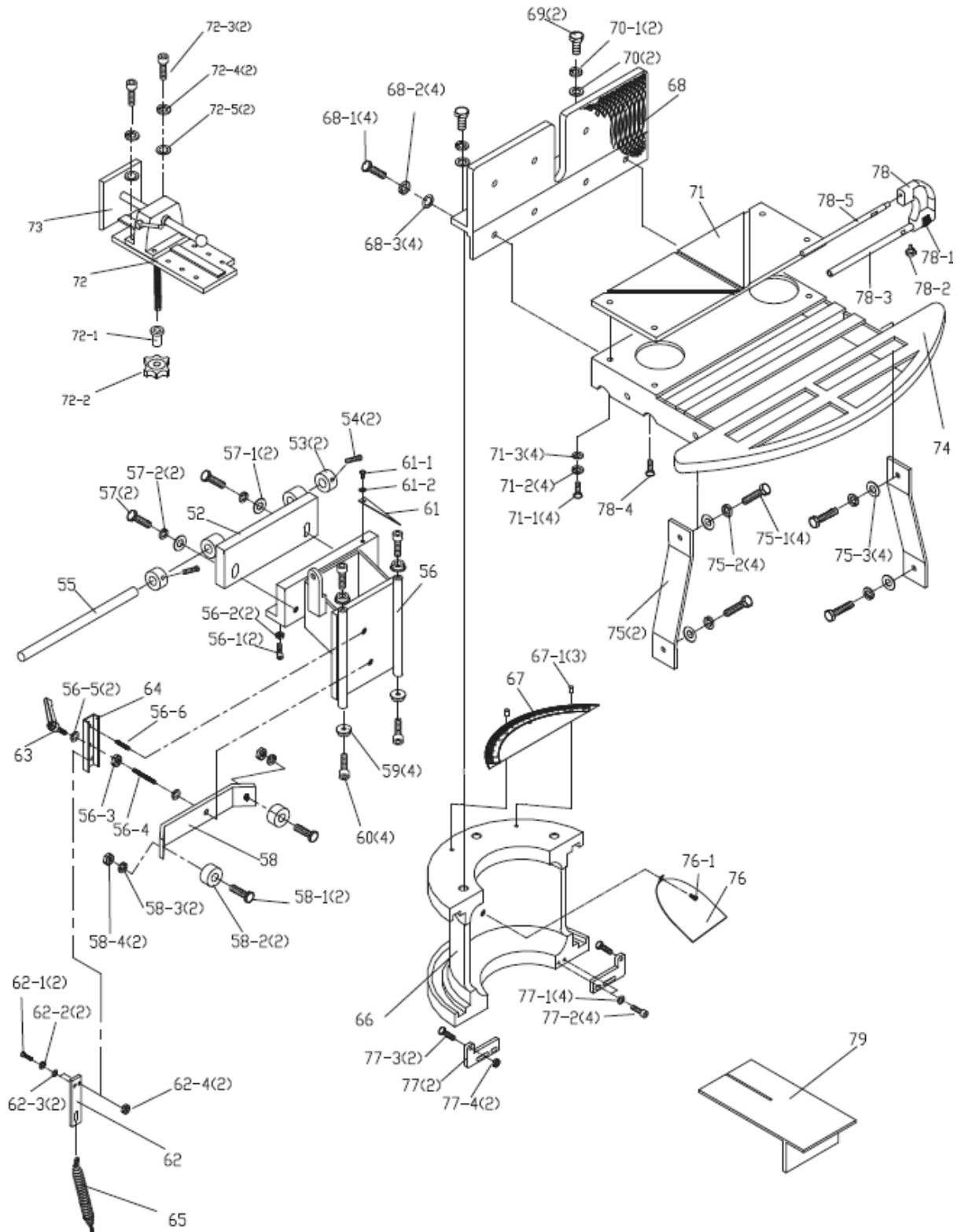

11.2.3 HVBS-10-DMW/DMWC Motor and Support Arm Assembly – Exploded View

Figure 11-8

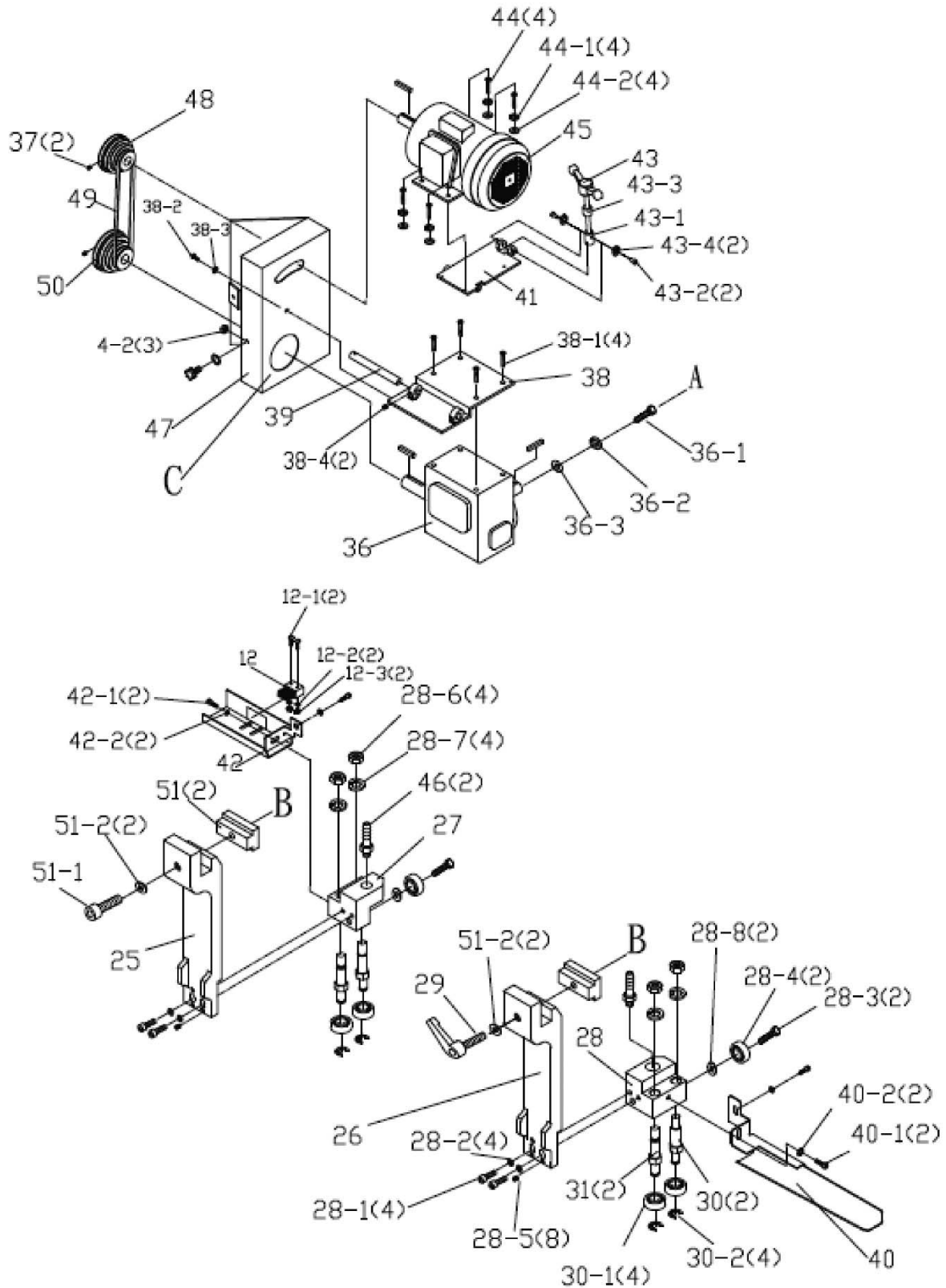

11.2.4 HVBS-10-DMW/DMWC Vise and Table Assembly – Exploded View

Figure 11-9

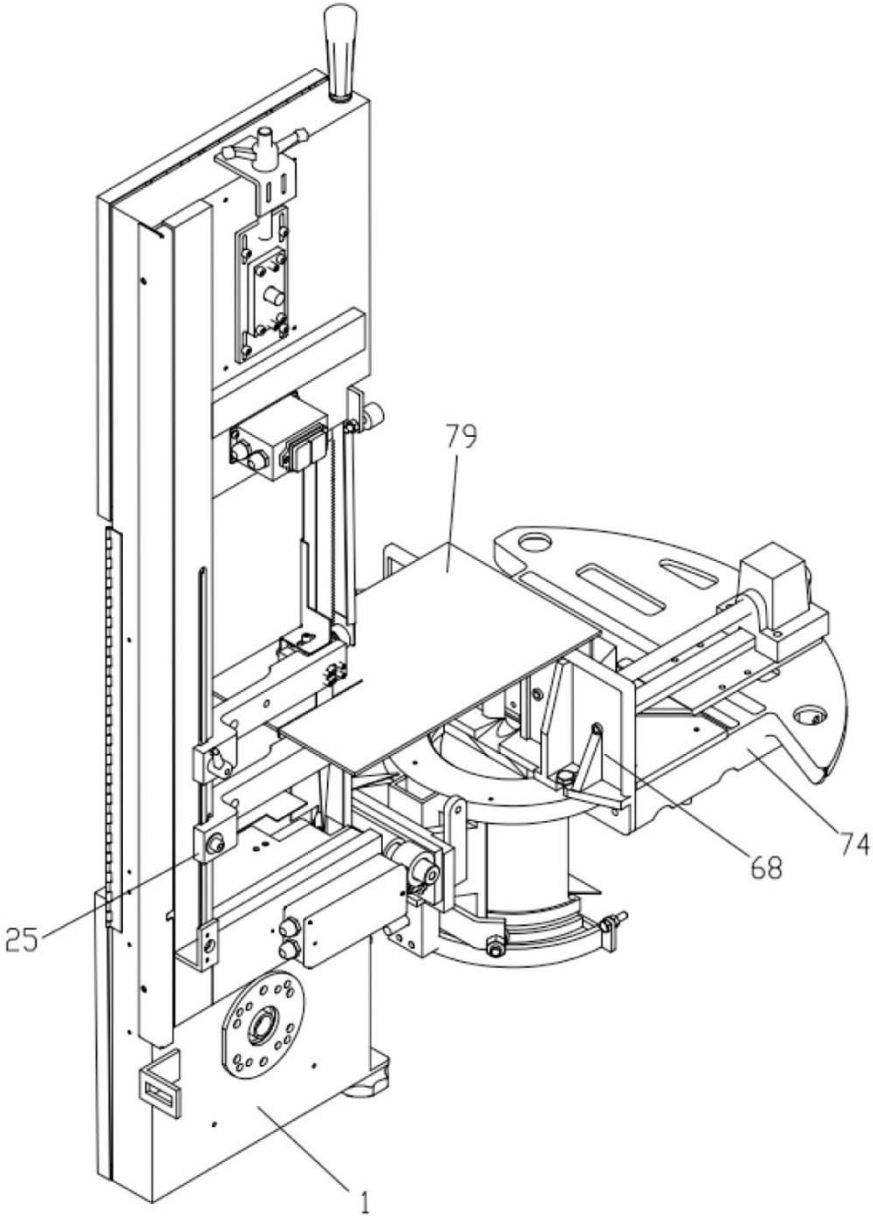

11.2.5 HVBS-10-DMW/DMWC Base Assembly – Exploded View

Figure 11-10

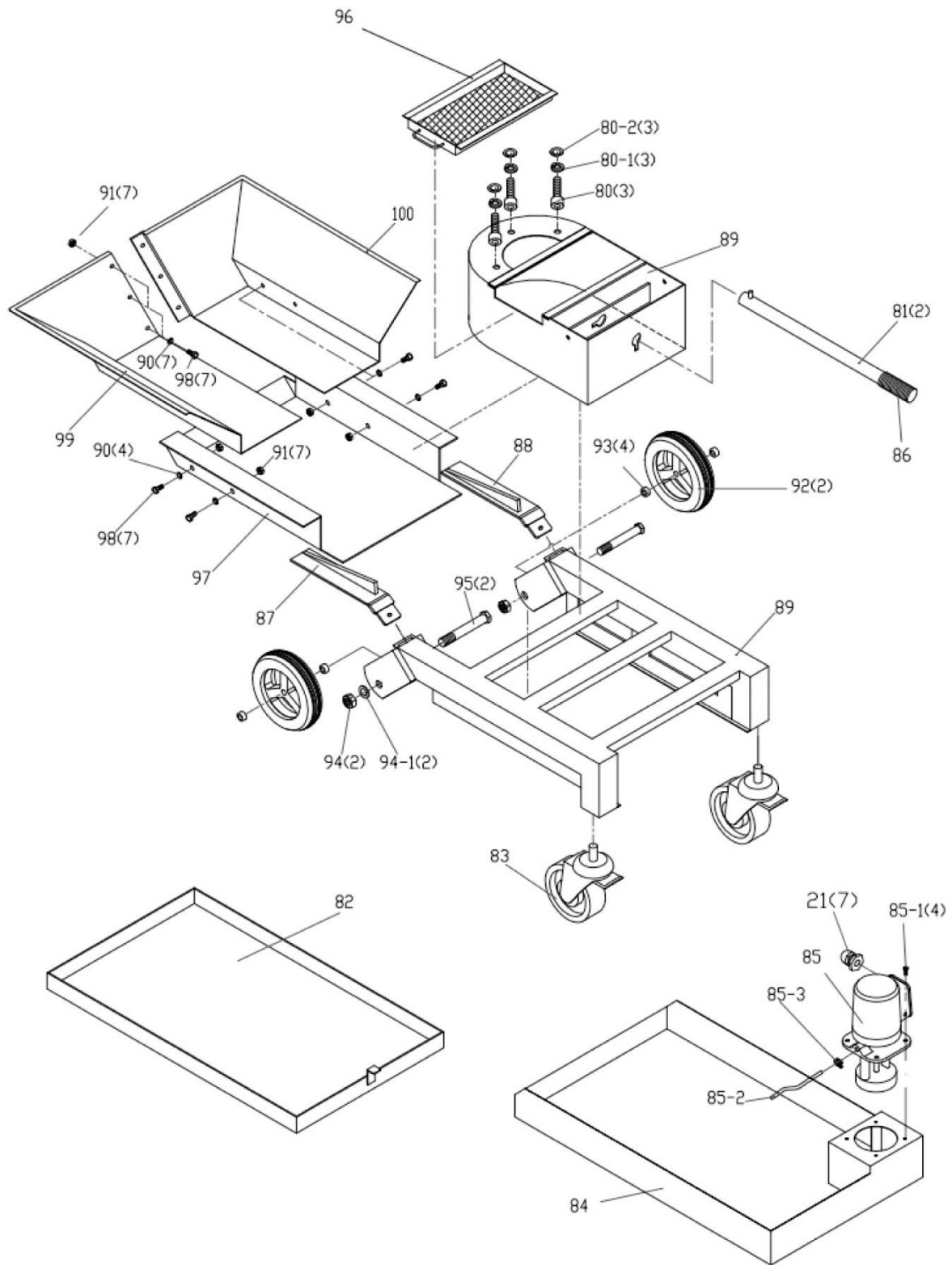

11.2.6 HVBS-10-DMW/DMWC – Parts List

Index No	Part No	Description	Size	Qty
1	HVBS-10-DMW-1	Saw Bow		1
1-1	HVBS-10-DMW-1-1	Screw		1
1-2	TS-0570021	Hex Nut	5/16"-18NC	2
1-3	TS-1490081	Hex Cap Bolt	M8-1.25x45L	1
1-4	TS-1524051	Set Screw	M8-1.25x20L	2
1-5	TS-1540061	Hex Nut	M8-1.25	2
1-6	TS-2171012	Phillips Pan Hd Machine Screw	M4-0.7x6L	1
2	HVBS-10-DMW-2	Idler Wheel Guard		1
3	HVBS-10-DMW-3	Drive Wheel Guard		1
4	HVBS-10-DMW-4	Handle		3
4-1	TS-1550041	Flat Washer	6x16x2 mm	3
4-2	TS-2311061	Hex Nut	M6-1.0	3
4-3	HVBS-10-DMW-4-3	Guard Prop		2
4-4	TS-1540061	Hex Nut	M8-1.25	4
4-5	HVBS-10-DMW-4-5	Grommet		4
5	HVBS-10-DMW-5	Upper Blade Guard		1
6	HVBS-10-DMW-6	Saw Blade	5/8T, 1 x 0.035 x 120"L (27x0.9x3048mm)	1
7	HVBS-10-DMW-7	Idler Wheel		1
8	HVBS-10-DMW-8	Drive Wheel		1
8-1	HVBS-10-DMW-8-1	Spacer		1
9	HVBS-10-DMW-9	Tension Slider		1
10	HVBS-10-DMW-10	Idler Wheel Bearing		1
10-1	TS-1490031	Hex Cap Bolt	M8-1.25x20L	1
10-2	TS-2361081	Lock Washer	M8	1
10-3	TS-1550061	Flat Washer	8x25x2 mm	2
11	HVBS-10-DMW-11	Slider Cover		1
12	HVBS-8-DMW-43	Brush		1
12-1	F001187	Philips Pan Hd Machine Screw	M4x25	2
12-2	TS-1550021	Flat Washer	M4	2
12-3	TS-1540021	Hex Nut	M4	2
13	TS-2311161	Hex Nut	M16-2.0	1
14	TS-1482041	Hex Cap Bolt	M6-1.0x20L	4
14-1	TS-2361061	Lock Washer	M6	4
14-2	TS-1550041	Flat Washer	6x13x1 mm	8
14-3	TS-1482061	Hex Cap Bolt	M6-1.0x30L	4
14-4	TS-1524051	Set Screw	M8-1.25x20L	2
14-5	TS-2311081	Hex Nut	M8-1.25	2
14-6	TS-1540041	Hex Nut	M6-1.0	4
15	HVBS-10-DMW-15	Handle		1
16	HVBS-10-DMW-16	Terminal Block		2
17	HVBS-10-DMW-17	Pump Cable Holder		1
18	HVBS-10-DMW-18	Limit Switch Bracket		1
18-1	TS-1533032	Phillips Pan Hd Machine Screw	M5-0.8x10L	2
18-2	TS-2361051	Lock Washer	M5	2
18-3	TS-1550021	Flat Washer	4x10x1 mm	2
19	HVBS-10-DMW-19	Switch Box		1
19-1	TS-2284082	Phillips Pan Hd Machine Screw	M4-0.7x8L	4
19-2	HVBS-10-DMW-19-2	Pushbutton Assembly		1
20	BB-6205ZZ	Bearing	6205ZZ	2
21	HVBS-10-DMW-21	Strain Relief	PG-9	7
22	HVBS-10-DMW-22	Limit Switch		1
22-1	F001187	Phillips Pan Hd Machine Screw	M4-0.7x25L	2
22-2	TS-1540021	Hex Nut	M4-0.7	2
23	HVBS-10-DMW-23	Upper Cable Cover		1
23-1	TS-1534032	Phillips Pan Hd Machine Screw	M6-1.0x10L	2
24	HVBS-10-DMW-24	Junction Box		1
24-1	HVBS-10-DMW-24-1	Cover		1
24-2	TS-2284082	Phillips Pan Hd Machine Screw	M4-0.7x8L	4
25	HVBS-10-DMW-25	Fixed Guide Arm		1
26	HVBS-10-DMW-26	Movable Guide Arm		1

Index No	Part No	Description	Size	Qty
27	HVBS-10-DMW-27	Fixed Guide Carbide		1
28	HVBS-10-DMW-28	Movable Guide Carbide		1
28-1	TS-1503061	Hex Socket Cap Screw	M6-1.0x25L	4
28-2	TS-1550041	Flat Washer	6x13x1 mm	4
28-3	TS-1504041	Hex Socket Cap Screw	M8-1.25x20L	2
28-4	BB-608ZZ	Bearing	608ZZ	2
28-5	TS-1523051	Set Screw	M6-1.0x16L	8
28-6	TS-1540061	Hex Nut	M8	4
28-7	TS-2361081	Lock Washer	M8	4
28-8	HVBS-10-DMW-28-8	Flat Washer	8x25x2 mm	2
29	HVBS-10-DMW-29	Handle	TR80 3/8x30L	1
30	HVBS-10-DMW-30	Shaft		2
30-1	BB-5200ZZ	Bearing	5200ZZ	4
30-2	PB85-115	E-clip	E7	4
31	HVBS-10-DMW-31	Eccentric Shaft		2
32	HVBS-10-DMW-32	Hydraulic Cylinder		1
32-1	HVBS-10-DMW-32-1	Linch Pin		1
32-2	TS-1504051	Hex Socket Cap Screw	M8-1.25x25L	1
32-3	HVBS-10-DMW-32-3	Shaft		1
33	HVBS-10-DMW-33	Handle		1
33-1	TS-1540081	Hex Nut	M12-1.75	1
34	HVBS-10-DMW-34	Spring Holder		1
35	HVBS-10-DMW-35	Bolt	1/2"	1
35-1	TS-0561051	Hex Nut	1/2"	1
36	HVBS-10-DMW-36	Gearbox		1
36-1	TS-0081031	Hex Cap Bolt	5/16"-18NCx3/4"L	1
36-2	TS-0720081	Lock Washer	5/16"	1
36-3	TS-0680031	Washer	5/16"x30x3	1
36-4	TS-1524051	Set Screw	M8-1.25x20L	4
36-5	TS-0208041	Hex Socket Cap Screw	5/16-18NCx3/4"L	4
37	6294761	Key, Double Rd Hd	6x45L mm	1
37-1	BDB1340-H63	Key, Double Rd Hd	5x35L mm	1
38	HVBS-10-DMW-38	Motor Tilt Plate		1
38-1	F000794	Phillips Pan Hd Machine Screw	5/16"-18NCx3/4L	4
38-2	F009919	Button Head Socket Screw	M5-0.8x6L	1
38-3	TS-1550031	Flat Washer	5x10x1 mm	1
38-4	TS-1523031	Set Screw	M6-1.0x10L	2
39	HVBS-10-DMW-39	Shaft		1
40	HVBS-10-DMW-40	Blade Guard		1
40-1	TS-1503021	Hex Socket Cap Screw	M6-1.0x10L	2
40-2	TS-1550041	Flat Washer	6x13x1 mm	2
41	HVBS-8-DMW-41	Motor Mount		1
42	HVBS-10-DMW-42	Blade Guard		1
42-1	TS-1503021	Hex Socket Cap Screw	M6-1.0x10L	1
42-2	TS-1550041	Flat Washer	6x13x1.5 mm	2
43	HVBS-8-DMW-42	Handle		1
43-1	HVBS-8-DMW-40	Screw		1
43-2	TS-1503031	Hex Socket Cap Screw	M6-1.0x12L	2
43-3	HVBS-8-DMW-42-1	Belt Tension Unit		1
44	TS-1482021	Hex Cap Bolt	M6-1.0x12L	4
44-1	TS-2361061	Lock Washer	M6	4
44-2	TS-1550041	Flat Washer	6x13x1 mm	4
45	HVBS-10-DMW-45	Motor	1HP 115/230V 1PH	1
	HVBS-10-DMW-45SC	Start Capacitor	300MFD 125VAC	1
	HVBS-10-DMW-45JB	Junction Box		1
	HVBS-10-DMW-45JBC	Junction Box Cover		1
	HVBS-10-DMW-45MF	Motor Fan		1
	HVBS-10-DMW-45MFC	Motor Fan Cover		1
45-1	HVBS-10-DMW-45-1	Key, Double Rd Hd	5x41 mm	1
46	HVBS-10-DMW-46	Hose Fitting	1/4" PT	1
47	HVBS-10-DMW-47	Pulley Box		1
47-1	TS-1482021	Hex Cap Bolt	M6-1.0x12L	2

Index No	Part No	Description	Size	Qty
47-2	TS-2361061	Lock Washer	M6	2
47-3	TS-1550041	Flat Washer	6x6x1.5 mm	2
48	HVBS-8-DMW-48	Motor Pulley		1
49	VB-A27	V-Belt	A27	1
50	HVBS-8-DMW-50	Gearbox Pulley		1
51	HVBS-8-DMW-52	T-Block		2
51-1	TS-0209061	Hex Socket Cap Screw	3/8"-16NCx1-1/4"L	1
51-2	TS-0680041	Flat Washer	3/8"x29x3	2
52	HVBS-8-DMW-57	Shaft Seat		1
53	HVBS-8-DMW-53	Collar		2
54	TS-1524011	Set Screw	M8-1.25x8L	2
55	HVBS-8-DMW-55	Bow Bearing Shaft		1
56	HVBS-8-DMW-56	Bracket		1
56-1	TS-1503061	Hex Socket Cap Screw	M6-1.0x25L	2
56-2	TS-2311061	Hex Nut	M6-1.0	2
56-3	TS-1540081	Hex Nut	M12-1.75	1
56-4	HVBS-10-DMW-56-4	Threaded Rod	M12-17.5x70L	1
56-5	TS-2360121	Flat Washer	12x24x3 mm	2
56-6	HVBS-10-DMW-56-6	Threaded Rod	M12-17.5x62L	1
57	F009536	Hex Socket Cap Screw	M12-1.75x30L	2
57-1	TS-2360121	Flat Washer	12x24x3 mm	2
57-2	TS-2361121	Lock Washer	M12	2
58	HVBS-8-DMW-58	Plate		1
58-1	TS-1492021	Hex Cap Bolt	M12-1.75x30L	2
58-2	BB-6001ZZ	Bearing	6001ZZ	2
58-3	TS-2361121	Lock Washer	M12	2
58-4	TS-1540081	Hex Nut	M12-1.75	2
59	HVBS-10-DMW-59	Special Washer		4
60	TS-1504041	Hex Socket Cap Screw	M8-1.25x20L	4
61	HVBS-8-DMW-61	Indicator		1
61-1	F009920	Button Head Socket Screw	M6-1.0x6L	1
61-2	HVBS-10-DMW-61-2	Flat Washer	6x6x1.5 mm	1
62	HVBS-8-DMW-62	Support		1
62-1	TS-1504051	Hex Socket Cap Screw	M8-1.25x25L	2
62-2	TS-2361081	Lock Washer	M8	1
62-3	TS-1550061	Flat Washer	8x16x1.0 mm	2
62-4	TS-1540061	Hex Nut	M8-1.25	2
63	HVBS-10-DMW-63	Handle	TRT100 M12	1
64	HVBS-8-DMW-64	Support Plate		1
65	HVBS-10-DMW-65	Tension Spring		1
66	HVBS-10-DMW-66	Lower Swivel Guide		1
67	HVBS-8-DMW-60	Angle Scale		1
67-1	F009919	Button Head Socket Screw	M5-1.0x6L	3
68	HVBS-10-DMW-68	Fixed Vise Jaw		1
68-1	TS-1504051	Hex Socket Cap Screw	M8-1.25x25L	4
68-2	TS-2361081	Lock Washer	M8	4
68-3	TS-1550061	Flat Washer	8x18x2 mm	4
69	TS-1504071	Hex Socket Cap Screw	M8-1.25x35L	2
70	TS-1550061	Flat Washer	8x25x3 mm	2
70-1	TS-2361081	Lock Washer	M8	2
71	HVBS-10-DMW-71	Aluminum Miter Plate		1
71-1	TS-1503051	Hex Socket Cap Screw	M6-1.0x20L	4
71-2	TS-2361061	Lock Washer	M6	4
71-3	TS-1550041	Flat Washer	6x16x2 mm	4
72	HVBS-10-DMW-72	Movable Jaw Mount		1
72-1	HVBS-10-DMW-72-2	Spacer		1
72-2	HVBS-10-DMW-72-2	Vise Lock Knob		1
72-3	TS-1504091	Hex Socket Cap Screw	M8-1.25x45L	2
72-4	TS-2361081	Lock Washer	M8	2
72-5	TS-1550061	Flat Washer	8x16x1.0 mm	2
73	HVBS-10-DMW-73	Movable Jaw Assembly		1
74	HVBS-10-DMW-74	Bed		1

Index No	Part No	Description	Size	Qty
75	HVBS-10-DMW-75	Bed Support		2
75-1	F005670	Hex Socket Cap Screw	M12-1.75x15L	4
75-2	TS-2361121	Lock Washer	M12	4
75-3	TS-2360121	Flat Washer	12x24x3 mm	4
76	HVBS-8-DMW-69	Chip Deflector		1
76-1	TS-2246102	Button Head Socket Screw	M6-1.0x10L	1
77	HVBS-8-DMW-78	45-Degree Plate		2
77-1	TS-1550041	Flat Washer	6x13x1 mm	4
77-2	TS-1503051	Hex Socket Cap Screw	M6-1.0x20L	4
77-3	TS-1490041	Hex Cap Bolt	M8-1.25x25L	2
77-4	TS-1540061	Hex Nut	M8	2
78	HVBS712-15	Work Stop		1
78-1	HVBS712-13	Threaded Collar		1
78-2	HVBS712-14	Plastic Knob		1
78-3	HVBS712-17	Lower Work Stop Rod		1
78-4	TS-1490031	Hex Cap Bolt	M8-1.25x20L	1
78-5	HVBS-8-DMW-80-1	Upper Work Stop Rod		1
79	HVBS-8-DMW-82	Vertical Cutting Platform		1
80	F009536	Hex Socket Cap Screw	M12-1.75x30L	3
80-1	TS-2361121	Lock Washer	M12	3
80-2	TS-2360121	Flat Washer	12x28x3 mm	3
81	HVBS-8-DMW-86	Handle		1
82	HVBS-10-DMW-82	Chip Drawer		1
83	HVBS-8-DMW-84	Swivel Caster	411 PU	2
84	HVBS-10-DMW-84	Coolant Tray		1
85	HVBS-10-DMW-85	Coolant Pump *	1/8HP 2P 1PH	1
85-1	TS-2286252	Phillips Pan Hd Machine Screw *	M6-1.0x25L	4
85-2	HVBS-10-DMW-85-2	Pipe *		1
85-3	HVBS-10-DMW-85-3	Metal Cable Tie *		1
86	HVBS-8-DMW-86-3	Grip		1
87	HVBS-10-DMW-87	Bracket (LH)		1
88	HVBS-10-DMW-88	Bracket (RH)		1
89	HVBS-8-DMW-85	Carriage		1
90	TS-1550041	Flat Washer	6x13x1 mm	4
91	TS-2311061	Hex Nut	M6	7
92	HVBS-8-DMW-88	Wheel		2
93	HVBS-10-DMW-93	Spacer		4
94	TS-0561071	Hex Nut	5/8"-11	2
94-1	TS-0680081	Flat Washer	5/8"	2
95	HVBS-10-DMW-95	Axle Bolt	5/8x5"	2
96	HVBS-10-DMW-96	Chip Screen		1
97	HVBS-10-DMW-97	Chip Bin Bottom Panel		1
98	HVBS-10-DMW-98	Button Head Socket Screw	M6-1.0x10L	7
99	HVBS-10-DMW-99	Chip Bin Left Panel		1
100	HVBS-10-DMW-100	Chip Bin Right Panel		1
101	HVBS-10-DMW-101	Holder		1
101-1	F012620	Hex Cap Bolt	M8-1.25x8L	2
101-2	TS-2361081	Lock Washer	M8	2
101-3	TS-1550061	Flat Washer	8x16x1.0 mm	2
102	HVBS-10-DMW-102	PU Hose (not shown)	5/16" x 5ft	1
	JET-138	JET Logo (not shown)	138x57mm	1
	LM000270	ID Label, HVBS-10DMW (not shown)		1
	LM000269	Label, Blade Speeds (not shown)		1
	LM000271	Warning Label (not shown)		1

* coolant pump provided only with model #424465 (optional accessory for #424463 model)

12.0 Electrical Connections for HVBS-DMW Band Saws

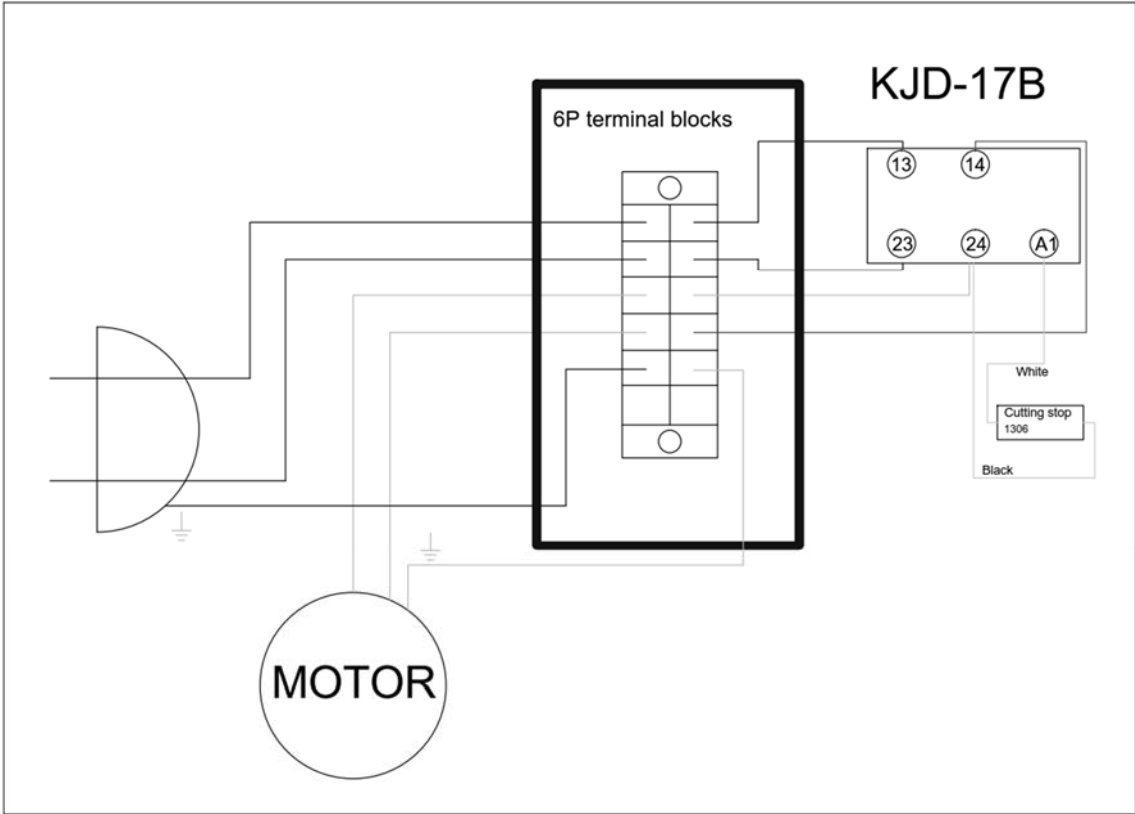

Figure 12-1

13.0 Warranty and service

JET warrants every product it sells against manufacturers' defects. If one of our tools needs service or repair, please contact Technical Service by calling 1-800-274-6846, 8AM to 5PM CST, Monday through Friday.

Warranty Period

The general warranty lasts for the time period specified in the literature included with your product or on the official JET branded website.

- JET products carry a limited warranty which varies in duration based upon the product. (See chart below)
- Accessories carry a limited warranty of one year from the date of receipt.
- Consumable items are defined as expendable parts or accessories expected to become inoperable within a reasonable amount of use and are covered by a 90 day limited warranty against manufacturer's defects.

Who is Covered

This warranty covers only the initial purchaser of the product from the date of delivery.

What is Covered

This warranty covers any defects in workmanship or materials subject to the limitations stated below. This warranty does not cover failures due directly or indirectly to misuse, abuse, negligence or accidents, normal wear-and-tear, improper repair, alterations or lack of maintenance. JET woodworking machinery is designed to be used with Wood. Use of these machines in the processing of metal, plastics, or other materials outside recommended guidelines may void the warranty. The exceptions are acrylics and other natural items that are made specifically for wood turning.

Warranty Limitations

Woodworking products with a Five Year Warranty that are used for commercial or industrial purposes default to a Two Year Warranty. Please contact Technical Service at 1-800-274-6846 for further clarification.

How to Get Technical Support

Please contact Technical Service by calling 1-800-274-6846. **Please note that you will be asked to provide proof of initial purchase when calling.** If a product requires further inspection, the Technical Service representative will explain and assist with any additional action needed. JET has Authorized Service Centers located throughout the United States. For the name of an Authorized Service Center in your area call 1-800-274-6846 or use the Service Center Locator on the JET website.

More Information

JET is constantly adding new products. For complete, up-to-date product information, check with your local distributor or visit the JET website.

How State Law Applies

This warranty gives you specific legal rights, subject to applicable state law.

Limitations on This Warranty

JET LIMITS ALL IMPLIED WARRANTIES TO THE PERIOD OF THE LIMITED WARRANTY FOR EACH PRODUCT. EXCEPT AS STATED HEREIN, ANY IMPLIED WARRANTIES OF MERCHANTABILITY AND FITNESS FOR A PARTICULAR PURPOSE ARE EXCLUDED. SOME STATES DO NOT ALLOW LIMITATIONS ON HOW LONG AN IMPLIED WARRANTY LASTS, SO THE ABOVE LIMITATION MAY NOT APPLY TO YOU.

JET SHALL IN NO EVENT BE LIABLE FOR DEATH, INJURIES TO PERSONS OR PROPERTY, OR FOR INCIDENTAL, CONTINGENT, SPECIAL, OR CONSEQUENTIAL DAMAGES ARISING FROM THE USE OF OUR PRODUCTS. SOME STATES DO NOT ALLOW THE EXCLUSION OR LIMITATION OF INCIDENTAL OR CONSEQUENTIAL DAMAGES, SO THE ABOVE LIMITATION OR EXCLUSION MAY NOT APPLY TO YOU.

JET sells through distributors only. The specifications listed in JET printed materials and on official JET website are given as general information and are not binding. JET reserves the right to effect at any time, without prior notice, those alterations to parts, fittings, and accessory equipment which they may deem necessary for any reason whatsoever. JET® branded products are not sold in Canada by JPW Industries, Inc.

Product Listing with Warranty Period

90 Days – Parts; Consumable items
1 Year – Motors; Machine Accessories
2 Year – Metalworking Machinery; Electric Hoists, Electric Hoist Accessories; Woodworking Machinery used for industrial or commercial purposes
5 Year – Woodworking Machinery
Limited Lifetime – JET Parallel clamps; VOLT Series Electric Hoists; Manual Hoists; Manual Hoist Accessories; Shop Tools; Warehouse & Dock products; Hand Tools; Air Tools

NOTE: JET is a division of JPW Industries, Inc. References in this document to JET also apply to JPW Industries, Inc., or any of its successors in interest to the JET brand.

This page intentionally left blank.



427 New Sanford Road
LaVergne, Tennessee 37086
Phone: 800-274-6848
www.jettools.com