

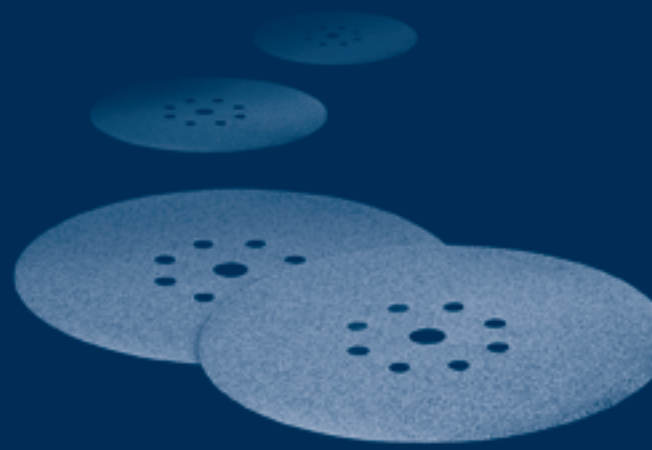

SERVICE  
all-inclusive



Catalogue

2015

**FESTOOL**

Tools for the toughest demands

# The Festool 18 Volt system.

Designed for greater independence  
and excellent working results.



## More information



### **Sawing and oscillating** 6

Pendulum jigsaws, plunge-cut saws, semi-stationary sawing, oscillator

### **Surface treatment** 48

Sanding, sanding with compressed air, polishing and oiling, brushing and texturing

### **Routing** 134

### **Planing** 188

### **Drilling and screwdriving** 198

### **The Festool 18 Volt system** 226

### **DOMINO joining system** 238

### **Edging** 250

### **Dust extraction** 262

### **Stirring** 298

### **Renovation, refurbishment and drywalling** 312

Routing, sanding, carpet and wallpaper removal

### **Timber construction** 332

### **Workplace organisation** 346

Guiding, holding, organising, workplace arrangement

### **Index** 384

01

02

03

04

05

06

07

08

09

10

11

12

13

90  
years



FESTOOL



Dear Festool customers,

Right from the start it was our aim to help you achieve the perfect result even quicker for your jobs, for every project. With solutions which help further optimise the work processes, increase the flexibility in daily work and, of course, open up completely new application possibilities with electric power tools.

Therefore, it is with great pleasure I present to you once again a complete range of new and further developed products in the current Festool main catalogue for 2015. Practical electric power tools customised to your applications, which are developed again and again from the findings in our most important think-tank: Your workshop.

Above all, our system for your perfect edge with the CONTURO KA 65 edge bander. Or the newly developed, extremely compact eccentric sander ETS EC 150 which sits directly in the hand. Or the cordless Festool 18 V system for powerful and precise sawing, screwdriving and drilling. A diverse, energy-efficient cordless range, which also represents ergonomic and persistent work thanks to the compact and lightweight design. Through to products, which open up new prospects in refurbishment and renovation, as well as in wooden structures.

And the following applies for each and every one of our tools: For 90 years now we have not left robustness and durability to chance – but to our German engineering skill and production experience.

When looking for your tool you will notice that we have once again done our utmost, because we are aware of your expectations and want to satisfy these now and also in the future.

We wish you lots of success in your projects.

Barbara Austel  
Partner

# SAFE INVESTMENT. GUARANTEED BENEFITS.

**New and available with every Festool machine.**

Simply register your machine online at [www.festool.co.uk/service](http://www.festool.co.uk/service) within 30 days of purchase to take advantage of the free SERVICE all-inclusive. Your local dealer will be happy to provide you with further assistance.\*



\* Valid for all Festool machines purchased after 2.4.2013 and registered for SERVICE all-inclusive within 30 days of purchase. Visit [www.festool.co.uk/service](http://www.festool.co.uk/service) for the applicable Festool Service Terms and Conditions.

**SERVICE**  
all-inclusive



### Cover for repair costs – Wear parts included

The 36-month cost protection guarantee now covers all wear parts so you won't receive any unwanted invoices for repairs. Plus our transport service will collect the machine from you at your request and return it again completely free of charge. \* \*\*

### Theft protection – even on the building site

Less complicated than insurance cover: In the event of a theft within 36 months of purchase, pay an excess fee of £100 inc VAT and receive a brand new machine. Cover includes theft from your car or the building site.\*

### No risk purchase

Money-back guarantee: Test our machines for 15 days after purchase. If you are not satisfied with the machine, simply return it to the dealer to receive a refund of the purchase amount.\*

### New spare part or replacement machine free of charge

We promise to stock spare parts for your machine for a minimum of 10 years. If not, we will send you a new replacement machine completely free of charge.\*



Visit [www.festool.co.uk/service](http://www.festool.co.uk/service) for information on the complete range of Festool services

\*\* The cost protection guarantee specified in our service conditions cannot be warranted in the following cases: damage to consumable materials and accessories, improper use, damage caused by use of non-original accessories or spare parts, machines dismantled independently and severe wear resulting from continuous use.





Overview of products and applications	8, 26
---------------------------------------	-------

#### Pendulum jigsaws

Pendulum jigsaws <b>TRION</b> PS 300, PSB 300	12
<b>CARVEX</b> pendulum jigsaws PS 420, PSB 420	13
<b>CARVEX</b> cordless pendulum jigsaws PSC 420, PSBC 420	14
Compact Module System <b>CMS</b> CMS PS 300	15

#### Circular saws

Circular saw TS 55 R	16
Cordless plunge-cut saw TSC 55	17
Plunge-cut saw TS 75	18

#### Semi-stationary sawing

Bench saw CMS-TS	19
<b>KAPEX</b> sliding compound mitre saws KS 88, KS 120	20
Compound mitre saw <b>SYMMETRIC</b> SYM 70	22
Bench-mounted trimming saws <b>PRECISIO</b> CS 50, CS 70	24

#### Oscillators

<b>VECTURO</b> oscillator OS 400	27
----------------------------------	----

Accessories and consumable materials	28
--------------------------------------	----

The Festool system

# Sawing and oscillating

## Overview of products and applications

Powerful. Precise. Robust. The impressive Festool pendulum jigsaws guarantee easy handling and rapid cutting progress. Available in body grip or D handle – optimised in every respect to achieve excellent results

Page 12 ————— 12 ————— 13 ————— 13

PS 300

PSB 300

PS 420

PSB 420



### Applications

#### Pendulum jigsaws TRION

#### CARVEX pendulum jigsaws, cable version

### Sawing with Jigsaws

Work independent of the mains power supply

Cut-outs for sinks and kitchen hobs

Trimming work on furniture, kitchens, for interior fitting

Cutting circles and curves

Coping end strips

Cutting workpieces to length

Edge notching on beams

Cutting from below

PS 300	PSB 300	PS 420	PSB 420
●	●	●	●
●	●	●	●
○	○	●	●
●	●	●	●
●	●	●	●
●	●	●	●
●	○	●	●

### Semi-stationary sawing

Cutting accurately along the scribe line

Precise coping during trimming work

Preliminary cutting work prior to routing shapes

### Technical data

	PS 300	PSB 300	PS 420	PSB 420
Power consumption (W)	720	720	550	550
Battery voltage (V)				
Li-ion battery capacity (Ah)				
Stroke rate (rpm)	1000-2900	1000-2900	1500-3800	1500-3800
Pendulum cover adjustment in stages	4	4	4	4
Inclination (°)	0-45	0-45		
Cutting depth in wood (mm)	120	120	120	120
Cutting depth in NF metals (mm)	20	20	20	20
Cutting depth in steel (soft) (mm)	10	10	10	10
Weight (kg)	2,4	2,4	1,9	1,9

# Sawing and oscillating

## Overview of products and applications

14 ——— 14 ——— 15

PSC 420 Li 18

PSBC 420 Li 18

CMS PS 300



CARVEX pendulum jigsaws, 18 V cordless version

Compact Module System CMS



Extremely appropriate  Appropriate

			720
	18	18	
	5,2	5,2	
	1500-3800	1000-3800	1000-2900
	4	4	4
			0-45
	120	120	120
	20	20	20
	10	10	10
	2,4	2,4	2,4/5,7

# Sawing and oscillating

## Overview of products and applications

Introducing the saws from Festool.  
Accurate to the millimetre and splinter-free. Cut with the necessary force for each material yet are lightweight and easy to handle.

Page 16 — 17 — 18 — 19 — 19

TS 55 R

TSC 55

TS 75

CMS TS 55 R

CMS TS 75



### Applications

Circular saws

Cordless  
plunge-cut saws

Circular saws

Compact Module System  
CMS TS

#### Sawing with portable circular saws

- Cutting recesses in kitchen worktops
- Cutting doors to length
- Cutting chipboard to size
- Cutting house doors to size, up to 75 mm thick



#### Semi-stationary sawing

- Sawing panels and laminate
- Rip cuts in boards and panels
- Cutting plastic and steel cable ducts to size
- Cutting grooves to a defined depth
- Trimming aluminium and other non-ferrous metal profiles
- Trimming skirting boards and cornices up to 120 mm in height
- Trimming skirting board along the bisector
- Cutting strip material to fit

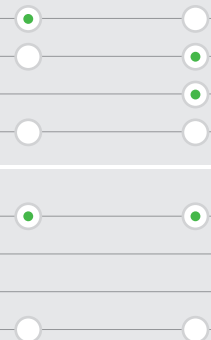

- Rip cuts with a maximum cutting depth of 51 mm
- Angled cuts 0-180°
- Rip cuts with a maximum cutting depth of 70 mm
- Sawing obscured cuts, grooves and rebates



#### Technical data

	1200	1600	1200	1600
Power consumption (W)	1200	1600	1200	1600
Idle engine speed (rpm)	2000-5200	1350-3550	2000-5200	1350-3550
Battery voltage (V)		1 x 18/2 x 18 (36)		
Li-ion battery capacity (Ah)		5,2		
Saw blade Ø (mm)	160	210	160	210
Cutting depth 90°/90° (mm)				
Cutting depth 45°/90° (mm)				
Cutting depth (mm)	0-55	0-75		
Cutting depth 45° (mm)	0-43	0-55		
Cutting height 90°/45° (mm)			0-51/0-38	0-70/0-48
Weight (kg)	4,5	6,2	4,5/7,8	6,2/9,5

20 ——— 21 ——— 22 ——— 24 ——— 25

**KS 88**                      **KS 120**                      **SYM 70**                      **CS 50**  
**CS 50 Set**                      **CS 70**  
**CS 70 Set**

**Sawing**  
for wooden structures  
Page 337



**KAPEX sliding compound mitre saws**



**Compound mitre saw SYMMETRIC**



**Bench-mounted trimming saws PRECISIO**

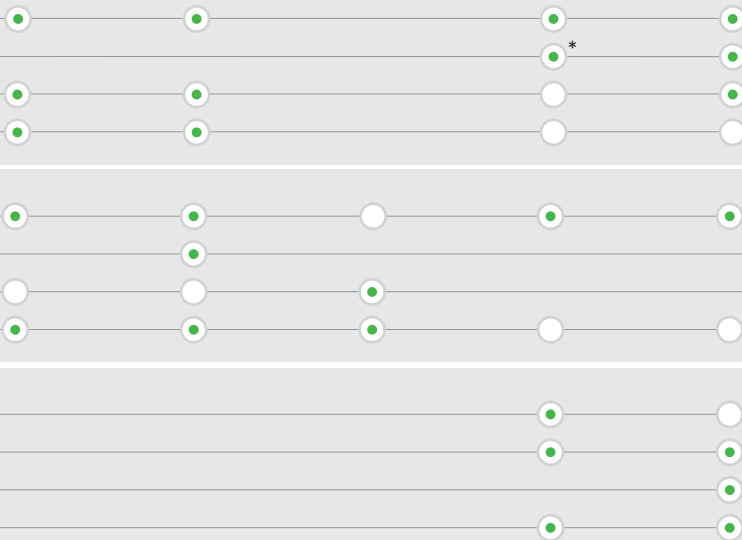

\* Set variants

● **Extremely appropriate** ○ **Appropriate**

	1600	1600	1150	1200	2200
	1400-3400	1400-3400	2700-5200	1600-4200	2000-4200
	260	260	216	190	225
	305 x 88	305 x 88			
	215 x 88	215 x 88			
					48
				0-52/0-37	0-70/0-48
	20,7	21,5	9,5	17,4/41,3	34,5/66

## Sawing and oscillating

Pendulum jigsaws TRION PS 300 and PSB 300



# TRION PS / PSB 300



### Ideal for flexible use.

- ▶ Patented three-way saw blade guide for cutting precise angles
- ▶ FastFix rapid-change system for easy saw blade changes
- ▶ Compatible in the system – integrated in the CMS system as a semi-stationary saw

#### Technical data

Power consumption (W)	720
Stroke rate (min <sup>-1</sup> )	1000-2900
Pendulum cover adjustment in stages	4
Inclination (°)	0-45
Cutting depth in wood (mm)	120
Cutting depth in NF metals (mm)	20
Cutting depth in steel (soft) (mm)	10
weight (kg)	2,4



= with MMC electronics

### Powerful and consistently accurate.

Rapid cutting progress and superior precision are just two of the impressive characteristics of the TRION PS 300. The patented three-way saw blade guide with parallel adjustable carbide jaws guarantees straight precision cuts.

Items Included	RRP in £*	Order no.
2 saw blades, splinterguard, in a SYSTAINER SYS 1 T-LOC		
<b>PS 300 EQ-Plus GB 240V</b>	229,00 274,80	<b>561450</b>
<b>PS 300 EQ-Plus GB 110V</b>	229,00 274,80	<b>561449</b>
<b>PSB 300 EQ-Plus GB 240V</b>	229,00 274,80	<b>561459</b>
<b>PSB 300 EQ-Plus GB 110V</b>	229,00 274,80	<b>561457</b>

\* Recommended retail price of manufacturer. Dealer prices may vary.  
Excl. VAT.  
Incl. VAT.

System accessories  
from page 30



Jigsaw blades  
from page 38



## Sawing and oscillating CARVEX PS 420 and PSB 420 pendulum jigsaws

01



Brushless EC-TEC motor for a long service life and a high level of efficiency



product design award

2010

# CARVEX PS / PSB 420

### Lightweight. Handy. Unbeatable profile-cutting capacity.

- ▶ Excellent behaviour in curves thanks to threefold saw blade guide and rigid lifter rod
- ▶ Simple handling thanks to the softgrip and ergonomic design
- ▶ Electronic switch-on/off on both sides, reachable in every grip position
- ▶ Fast, tool-free changing of tables, baseplates and saw blades

Technical data	PS 420	PSB 420
Power consumption [W]	550	550
Stroke rate [min <sup>-1</sup> ]	1500-3800	1000-3800
Pendulum cover adjustment in stages	4	4
Cutting depth in wood [mm]	120	120
Cutting depth in NF metals [mm]	20	20
Cutting depth in steel (soft) [mm]	10	10
weight [kg]	1,9	1,9



■ = with MMC electronics

Items Included	RRP in £*	Order no.
2 saw blades, splinterguard, in a SYSTAINER SYS 1 T-LOC		
<b>PS 420 EBQ-Plus GB 240V</b>	286,00 343,20	<b>561590</b>
<b>PS 420 EBQ-Plus GB 110V</b>	286,00 343,20	<b>561589</b>
<b>PS 420 EBQ-Set GB 240V</b>	438,00	<b>561591</b>
accessories SYSTAINER	525,60	
<b>PS 420 EBQ-Set GB 110V</b>	438,00	<b>561592</b>
accessories SYSTAINER	525,60	
<b>PSB 420 EBQ-Plus GB 240V</b>	286,00 343,20	<b>561605</b>
<b>PSB 420 EBQ-Plus GB 110V</b>	286,00 343,20	<b>561604</b>
<b>PSB 420 EBQ-Set GB 240V</b>	438,00	<b>561606</b>
accessories SYSTAINER	525,60	
<b>PSB 420 EBQ-Set GB 110V</b>	438,00	<b>561607</b>
accessories SYSTAINER	525,60	

\* Recommended retail price of manufacturer. Dealer prices may vary.  
Excl. VAT.  
Incl. VAT.

System accessories  
from page 30



Jigsaw blades  
from page 38



Watch the product video



### Follows only one line. Yours.

Power that you can feel. Revolutionary technology that makes the tightest curve feel like you are cutting in a straight line. It is the combination of outstanding features that makes the CARVEX PS 420 such an exceptional pendulum jigsaw.

## Sawing and oscillating

CARVEX PSC 420 and PSBC 420 cordless pendulum jigsaws



Brushless EC-TEC motor for a long service life and a high level of efficiency



# CARVEX PSC / PSBC 420



### The cordless version of CARVEX – hard working and powerful.

- ▶ Particularly efficient with lithium-ion batteries
- ▶ Battery packs for drills from C and T series can be used
- ▶ Excellent behaviour in curves thanks to threefold saw blade guide and rigid lifter rod
- ▶ Simple handling thanks to the softgrip and ergonomic design

Technical data	PSC 420 Li 18	PSBC 420 Li 18
Battery voltage (V)	18	18
Stroke rate (min <sup>-1</sup> )	1500-3800	1000-3800
Pendulum cover adjustment in stages	4	4
Cutting depth in wood (mm)	120	120
Cutting depth in NF metals (mm)	20	20
Cutting depth in steel (soft) (mm)	10	10
Li-Ion battery capacity (Ah)	5,2	5,2
weight (kg)	2,4	2,4



■ = with MMC electronics

### Perfect combination of power and flexibility.

What do you get when you cross a powerful cutting stroke with effortless handling around bends and corners? Pure enthusiasm for the CARVEX. Also innovative battery technology that provides greater flexibility. It matches the high cutting performance achieved with cabled versions, is long-lasting and superior to other cordless saws.

Items Included	RRP in £*	Order no.
2 saw blades, splinterguard, in a SYSTAINER SYS 2 T-LOC		
<b>PSC 420 EB Li-Basic</b> without battery pack, without charger, rubberised frame for battery packs	263,00 315,60	<b>561738</b>
<b>PSBC 420 EB Li-Basic</b> without battery pack, without charger, rubberised frame for battery packs	263,00 315,60	<b>561739</b>
<b>PSC 420 EB Li 18-Plus GB 240V</b> TCL 3 charger, battery pack BPC 18 Li 5.2 Ah	382,00 458,40	<b>561747</b>
<b>PSBC 420 EB Li 18-Plus GB 240V</b> TCL 3 charger, battery pack BPC 18 Li 5.2 Ah	382,00 458,40	<b>561751</b>
<b>PSC 420 EB Li 18-Set GB 240V</b> accessories SYSTAINER, TCL 3 charger, battery pack BPC 18 Li 5.2 Ah	536,00 643,20	<b>561741</b>
<b>PSBC 420 EB Li 18-Set GB</b> accessories SYSTAINER, TCL 3 charger, battery pack BPC 18 Li 5.2 Ah	536,00 643,20	<b>561744</b>

\* Recommended retail price of manufacturer. Dealer prices may vary.  
Excl. VAT.  
Incl. VAT.

System accessories  
from page 30

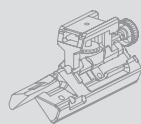

Jigsaw blades  
from page 38



Watch the product video







# CMS-PS



### Jigsaw for the CMS system.

- ▶ Module carrier for installing jigsaws to form a jigsaw module
- ▶ Also available with jigsaw PS 300
- ▶ The jigsaw can be used not only as a bench-mounted tool, but also as a handheld tool
- ▶ Flexible extension options – for an even wider range of applications

#### Technical data

Power consumption (W)	720
Stroke rate (min <sup>-1</sup> )	1000-2900
Pendulum cover adjustment in stages	4
Cutting depth in wood (mm)	120
Cutting depth in NF metals (mm)	20
Inclination (°)	0-45
Cutting depth in steel (soft) (mm)	10
Connection Ø d/e (mm)	27
Dimensions module support (mm)	578 x 320
Weight module support (kg)	3,3
weight (kg)	2,4



■ = with MMC electronics

Items Included	RRP in £*	Order no.
module support, assembly lugs, operation tool, in a carton		
<b>CMS-PS</b>	144,00 172,80	<b>561262</b>

### From mobile to stationary in a matter of seconds.

This module mounting is used to equip jigsaws for stationary work. For cutting shapes and curves accurately as well as minor notching during trimming work.

\* Recommended retail price of manufacturer. Dealer prices may vary.  
Excl. VAT.  
Incl. VAT.

CMS system overview  
from page 348



Jigsaw blades  
from page 38



## Sawing and oscillating

### Circular saw TS 55 R

# TS 55 R



### Even more precise. Flat body.

Many of the standard features of today's portable circular saws originated from the TS 55. The TS 55 is now starting the next chapter in its success story with a wide range of innovations such as an ultra slimline housing for even greater flexibility, a recently developed guide wedge for even greater safety and precision and many other ideas that make the TS 55 R the best plunge-cut saw we have ever built.

### The best plunge-cut saw we have ever built.

- ▶ Slimline housing for maximum flexibility and close proximity to the wall (12 mm)
- ▶ Angle adjustment with undercut function from -1 to 47°
- ▶ Guide wedge for safer work and simple positioning in existing joint
- ▶ Transparent sliding viewing window provides a good view of the scribe mark and saw blade

#### Technical data

Power consumption (W)	1200
Idle engine speed (min <sup>-1</sup> )	2000-5200
Idle engine speed (min <sup>-1</sup> )	
Saw blade diameter (mm)	160
Angular range (°)	-1-47
Cutting depth (mm)	0-55
Cutting depth at 45 degrees (mm)	0-43
Connection Ø d/e (mm)	27/36
weight (kg)	4,5



= with MMC electronics

Items Included	RRP in £*	Order no.
splinterguard, Flag window; vision panel, operation tool, in a SYSTAINER SYS 4 T-LOC		
<b>TS 55 REQ-Plus GB 110V</b> fine tooth saw blade HW W48	394,00 472,80	<b>561554</b>
<b>TS 55 REQ-Plus-FS GB 110V</b> fine tooth saw blade HW W48 491952, guide rail FS 1400/2 491498	438,00 525,60	<b>561584</b>
<b>TS 55 REBQ-Plus GB 240V</b> fine tooth saw blade HW W48	394,00 472,80	<b>561553</b>
<b>TS 55 REBQ-Plus-FS GB 240V</b> fine tooth saw blade HW W48, guide rail FS 1400/2	438,00 525,60	<b>561583</b>

\* Recommended retail price of manufacturer. Dealer prices may vary.  
Excl. VAT.  
Incl. VAT.

#### System accessories from page 31

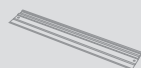

#### Circular saw blades from page 42



#### Watch the product video



## Sawing and oscillating

### Cordless plunge-cut saw TSC 55

01



Brushless EC-TEC motor for a long service life and a high level of efficiency

# TSC 55



### Sawing perfection with no compromises – except the socket!

The new cordless plunge-cut saw TSC 55 – developed with a clear image in view when you are working: The TS 55 R. And a result which moves to this high level in terms of performance, power and precision. The dual battery concept can be freely combined with 18 V/18 V, 18 V/15 V or 15 V/15 V, or you can saw using only one battery. As required: full power or minimal weight.

### Our best plunge-cut saw is now independent.

- ▶ Brushless EC-TEC motor combined with lithium-ion batteries for maximum cutting power
- ▶ Flexible dual battery concept: can be operated with two 18-volt battery packs (36V) for maximum power or one 18-volt battery pack for low weight
- ▶ High-speed EC-TEC motor for perfect cutting quality and rapid working progress
- ▶ Chip collection bag for clean, healthy working

#### Technical data

Battery voltage (V)	18/36
Idle engine speed (min <sup>-1</sup> )	2650-3800/5200
Saw blade diameter (mm)	160
Angular range (°)	-1-47
Cutting depth (mm)	0-55
Cutting depth at 45 degrees (mm)	0-43
Connection Ø d/e (mm)	27/36
Li-Ion battery capacity (Ah)	5,2
Weight 1x18V/2x18V (kg)	4,6/5,3



■ = with MMC electronics

Items Included	RRP in £*	Order no.
fine tooth saw blade HW W48, chip collection bag, splinterguard, Flag window; vision panel, operation tool, in a SYSTAINER SYS 5 T-LOC		
<b>TSC 55 REB Li-Basic</b> without battery pack, without charger	384,00 460,80	<b>561737</b>
<b>TSC 55 REB-Plus Li GB 240V</b> spare battery pack lithium-ion 5.2 Ah, TCL 3 charger	580,00 696,00	<b>561713</b>
<b>TSC 55 REB-Plus/XL Li GB 240V</b> spare battery pack lithium-ion 5.2 Ah, spare charger TCL 3	622,00 746,40	<b>561717</b>
<b>TSC 55 REB-Plus-FS Li GB 240V</b> spare battery pack lithium-ion 5.2 Ah, TCL 3 charger, guide rail FS 1400/2	622,00 746,40	<b>561721</b>
<b>TSC 55 REB-Plus/XL-FS Li GB 240V</b> spare battery pack lithium-ion 5.2 Ah, spare charger TCL 3, guide rail FS 1400/2	666,00 799,20	<b>561725</b>

\* Recommended retail price of manufacturer. Dealer prices may vary.  
Excl. VAT.  
Incl. VAT.

System accessories  
from page 31



Circular saw blades  
from page 42



Watch the product video



## Sawing and oscillating

### Circular saw TS 75



# TS 75



### 75 mm cuts and no competition.

The cutting depth of 75 mm and the famous circular principle are ideal for jobs involving larger workpieces and enable you to saw thick workpieces with one cut. This saves you having to turn the workpiece and minimises reworking.

### Large saw with depth.

- ▶ 75 mm cutting depth for even more application possibilities
- ▶ FastFix: quick and easy saw blade changing and adapting to the working material
- ▶ Safe and convenient – with sliding clutch and kickback stop
- ▶ Spring-loaded spacer wedge for unhindered plunge cuts and safe working progress

#### Technical data

Power consumption (W)	1600
Idle engine speed (min <sup>-1</sup> )	1350-3550
Saw blade diameter (mm)	210
Angular range (°)	0-47
Cutting depth (mm)	0-75
Cutting depth at 45 degrees (mm)	0-55
Connection Ø d/e (mm)	27/36
weight (kg)	6,2



= with MMC electronics

Items Included	RRP in £*	Order no.
HW universal saw blade W 36, splinterguard, operation tool, in a SYSTAINER SYS 5 T-LOC		
<b>TS 75 EQ-Plus-FS GB 110V</b>	585,00	<b>561259</b>
guide rail FS 1400/2	702,00	
<b>TS 75 EQ-Plus GB 110V</b>	537,00	<b>561439</b>
	644,40	
<b>TS 75 EBQ-Plus GB 240V</b>	537,00	<b>561441</b>
kickback stop	644,40	
<b>TS 75 EBQ-Plus-FS GB 240V</b>	585,00	<b>561514</b>
kickback stop, guide rail FS 1400/2	702,00	

\* Recommended retail price of manufacturer. Dealer prices may vary.  
Excl. VAT.  
Incl. VAT.

#### System accessories from page 31

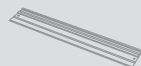

#### Circular saw blades from page 42





CMS-TS



**A workshop does not have to be big.**

With the CMS modules, plunge-cut saws can be transformed into bench saws for a wide range of applications. Rip, cross and angled cuts as well as changing quickly from rip to cross cuts is so quick and easy. The transparent protective hood provides a good view of the workpiece and cut.

**Circular saw for the CMS system.**

- ▶ Module carrier for installing plunge-cut saws to form a bench saw module
- ▶ Also available with plunge-cut saw
- ▶ The plunge-cut saw can be used not only as a bench-mounted tool, but also as a handheld tool
- ▶ Flexible extension options – for an even wider range of applications

Technical data	CMS TS 55	CMS TS 75
Power consumption (W)	1200	1600
Idle engine speed (min <sup>-1</sup> )	2000-5200	1350-3550
Saw blade diameter (mm)	160	210
Cutting height 90°/45° (mm)	0-51/0-38	0-70/0-48
Connection Ø d/e (mm)	27/36	27/36
Dimensions module support (mm)	578 x 320	578 x 320
Weight module support (kg)	3,3	3,3
weight (kg)	7,8	9,5



☐ = with MMC electronics

Items Included	RRP in £*	Order no.
module support, protective cover with supporter, fixing clamps, angle stop, scales, workpiece holder, cutting depth adjustment		
<b>CMS-TS 55 R</b>	262,00	<b>570281</b>
switching terminal, in a carton	314,40	
<b>CMS-TS 75</b>	277,00	<b>493360</b>
clamp for switch and splitting wedge, in a carton	332,40	
<b>CMS-MOD-TS 55 R</b>	629,00	<b>570282</b>
circular saw TS 55 REBQ-Plus, switching terminal, fine tooth saw blade HW W48, operation tool	754,80	

\* Recommended retail price of manufacturer. Dealer prices may vary.  
Excl. VAT.  
Incl. VAT.

CMS system overview  
from page 348



Circular saw blades  
from page 42



## Sawing and oscillating

Sliding compound mitre saw KAPEX KS 88



# KAPEX KS 88



### Compact, lightweight, unbeatably versatile.

The KS 88 has an impressive cutting capacity of 88 mm and a particularly compact, lightweight design. For precision results in workshop or assembly applications.

### Less weight, but better performance.

- ▶ Twin-column guide with two bearings for unique precision
- ▶ Compact, lightweight design for convenient transportation
- ▶ Intelligent details such as an angle preselection and quick-release clamp for rapid adjustment of the inclination angle
- ▶ FastFix: quick and easy saw blade changing and adapting to the working material

#### Technical data

Power consumption [W]	1600
Idle engine speed (min <sup>-1</sup> )	1400-3400
Saw blade diameter (mm)	260
Cutting depth 90°/90° (mm)	305 x 88
Cutting depth at 45°/90° (mm)	215 x 88
Cutting depth 45°/45° (right) (mm)	215 x 35
Crown moulding dia. cut 45°/90° (mm)	168
Cutting depth 60°/90° (right) (mm)	152 x 88
Cutting depth 45°/45° (left) (mm)	215 x 55
Mitre angle [°]	50/60
Bench height (on MFT) (mm)	790



= with MMC electronics

Items Included	RRP in £*	Order no.
HW universal saw blade W60, workpiece clamp, operation tool, in a carton		
<b>KS 88 E GB 240V</b>	754,00 904,80	<b>561400</b>
<b>KS 88 E GB 110V</b>	754,00 904,80	<b>561399</b>
<b>KS 88 UG-Set GB 240V</b>	1.259,00 1.510,80	<b>561413</b>
KS 88 E, underframe, adjustable stop, telescopic slide-out scale, fold-out pedestal and carry case		
<b>KS 88 UG-Set GB 110V</b>	1.259,00 1.510,80	<b>561414</b>
KS 88 E, underframe, adjustable stop, telescopic slide-out scale, fold-out pedestal and carry case		

\* Recommended retail price of manufacturer. Dealer prices may vary.  
Excl. VAT.  
Incl. VAT.

#### System accessories from page 32



#### Circular saw blades from page 42





## KAPEX KS 120

**Quality down to the finest detail.**

- ▶ Twin-column guide with two bearings for unique precision
- ▶ Dual-line laser for an accurate indication of the cutting line
- ▶ Fine adjustment for setting the saw blade angle accurate to the millimetre
- ▶ Special cutting position for cutting depths up to 120 mm

**Technical data**

Power consumption (W)	1600
Idle engine speed (min <sup>-1</sup> )	1400-3400
Saw blade diameter (mm)	260
Cutting depth 90°/90° (mm)	305 x 88
Cutting depth at 45°/90° (mm)	215 x 88
Special cutting depth 90°/90° (mm)	60 x 120
Cutting depth 60°/90° (right) (mm)	152 x 88
Cutting depth 45°/45° (right) (mm)	215 x 35
Crown moulding diagonal cut at 90°/90° (mm)	168
Mitre angle [°]	50/60
Bench height (on MFT) (mm)	790



■ = with MMC electronics

Items Included	RRP in £*	Order no.
HW universal saw blade W60, bevel, workpiece clamp, operation tool, in a carton		
<b>KS 120 EB GB 240V</b>	999,00 1.198,80	<b>561285</b>
<b>KS 120 EB GB 110V</b>	999,00 1.198,80	<b>561286</b>
<b>KS 120 UG-Set GB 240V</b>	1.485,00	<b>561417</b>
KS 120 EB, underframe, adjustable stop, telescopic slide-out scale, fold-out pedestal and carry case	1.782,00	
<b>KS 120 UG-Set GB 110V</b>	1.485,00	<b>561418</b>
KS 120 EB, underframe, adjustable stop, telescopic slide-out scale, fold-out pedestal and carry case	1.782,00	
<b>KS 120 EB Set GB 240V</b>	1.636,00	<b>561291</b>
multifunction table MFT KAPEX, clamping set, 2 table extensions, 2 crown moulding stop	1.963,20	
<b>KS 120 EB Set GB 110V</b>	1.636,00	<b>561292</b>
multifunction table MFT KAPEX, clamping set, 2 table extensions, 2 crown moulding stop	1.963,20	

\* Recommended retail price of manufacturer. Dealer prices may vary.  
Excl. VAT.  
Incl. VAT.

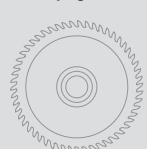
**System accessories  
from page 32****Circular saw blades  
from page 42****Maximum precision for the  
perfect cut.**

The impressive features of the KS 120 include an outstanding cutting capacity and low weight. The special cutting position allows you to cut coving and cornices in their original wall position. Intelligent details such as the dual-line laser and bevel ensure accurate results.

## Sawing and oscillating

Compound mitre saw SYMMETRIC SYM 70



# SYMMETRIC SYM 70



### Trimming strips could not be easier.

Precision has never been easier: measure and transfer the angle, make the cut and you're done. The patented symmetrical stop system on the SYMMETRIC SYM 70 simplifies your work considerably.

### Compound mitre saw.

- ▶ Patented symmetrical stop system
- ▶ Easy angle transfer using a bevel, cutting along the bisector without making calculations
- ▶ Stops easy to clamp, no tools required
- ▶ MMC electronics adapt to the working material

#### Technical data

Power consumption (W)	1150
Idle engine speed (min <sup>-1</sup> )	2700-5200
Saw blade diameter (mm)	216
Interior angle (°)	0-68
Exterior angle (°)	0-60
Max. strip height (mm)	70
Max. strip width (mm)	80
Connection Ø d/e (mm)	27/36
weight (kg)	9,5



= with MMC electronics

Items Included	RRP in £*	Order no.
fine tooth saw blade HW W48, precision adjustable square, operation tool, in a carton		
<b>SYM 70 E GB 240V</b>	621,00 745,20	<b>561256</b>

\* Recommended retail price of manufacturer. Dealer prices may vary.  
Excl. VAT.  
Incl. VAT.

System accessories  
from page 33



Circular saw blades  
from page 42







### The guide rail – reinvented.

#### A legend among professionals.

Guide rail, guide wedge, plunge-cut saw, three-way saw blade guide for pendulum jigsaws, twin-column guide with two bearings for the KAPEX sliding compound mitre saw ... You need look no further than Festool for all your sawing requirements. Our engineers and customers are the driving force behind innovations resulting in the development of electric saws that are ergonomic, lightweight, powerful and intuitive to operate.

### Increase precision. Reduce costs.

Adapting to the working material is worth it because the results are more accurate and the saw blades last much longer. Festool system features such as single-handed saw blade changing on the CARVEX and FastFix on the KAPEX and plunge-cut saws are designed to reduce set-up times.



### Reduce rework.

Immaculate and splinter-free cuts reduce painstaking rework. That's why Festool fitted two bearings to the KAPEX twin column guide, equipped the jigsaws with a third saw blade guide and invented the guide rail with a splinterguard.



### Power applied exactly where is needed.

The EC-TEC drive concept from Festool represents exceptional power utilisation using the least amount of energy across the entire speed range – 80% of the power generated is transferred to the saw blade. The EC-TEC motor runs without carbon brushes, and is therefore wear and maintenance free, and extremely sturdy.



## Sawing and oscillating

### Trimming saw PRECISIO CS 50



design award  
winner  
2003

# PRECISIO CS 50



### Full power perfectly under control.

- ▶ Tool-less FastFix saw blade changes
- ▶ Multifunction handle: one handle with all functions integrated
- ▶ Change quickly from rip to cross cuts with the angle stop
- ▶ Moving splinterguard for splinter-free cuts on both sides

Technical data	CS 50 EB	CS 50 EB-Set
Power consumption [W]	1200	1200
Idle engine speed [min <sup>-1</sup> ]	1600-4200	1600-4200
Saw blade diameter [mm]	190	190
Cutting height 90°/45° [mm]	0-52/0-37	0-52/0-37
Inclination [°]	0 [-2]° - 45 [+47]	0 [-2]° - 45 [+47]
Cutting path [mm]	304	304
Table dimensions [mm]	585 x 400	1010 x 810
Table height, legs folded away [mm]	316	316
Table height, legs unfolded [mm]	900	900
Connection Ø d/e [mm]	27/36	27/36
weight [kg]	17,4	41,3



☐ = with MMC electronics

### Diversity made easy.

The PRECISIO CS 50 is the perfect solution for cross and rip cuts in applications involving interior fitting, furniture assembly and exhibition stand construction. Thanks to its low weight and a host of ingenious functions, the CS 50 is ideal for applications where the nature of the work constantly changes, eg assembly tasks.

Items Included	RRP in €*	Order no.
HW universal saw blade W32, angle stop, foldaway legs, 3 splinterguards, dust extraction set, workpiece holder, operation tool, in a carton		
<b>CS 50 E GB 110V</b>	1.057,00 1.268,40	<b>561196</b>
<b>CS 50 E-Set GB 110V</b> ripping-cut fence, sliding table, extension table, extension table	1.586,00 1.903,20	<b>561204</b>
<b>CS 50 EB GB 240V</b>	979,00 1.174,80	<b>561194</b>
<b>CS 50 EB-Set GB 240V</b> ripping-cut fence, sliding table, extension table, extension table	1.586,00 1.903,20	<b>561202</b>

\* Recommended retail price of manufacturer. Dealer prices may vary.  
Excl. VAT.  
Incl. VAT.

#### System accessories from page 34

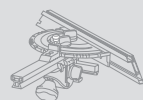

#### Circular saw blades from page 42



## Sawing and oscillating

### Trimming saw PRECISIO CS 70

01



# PRECISIO CS 70



### Solid, strong and uncompromising.

- ▶ Powerful motor for maximum cutting power, even through harder materials
- ▶ 70 mm cutting depth for an even wider range of applications
- ▶ Change quickly from rip to cross cuts with the angle stop
- ▶ Moving splinterguard for splinter-free cuts on both sides

Technical data	CS 70 EB	CS 70 EB-Set
Power consumption [W]	2200	2200
Idle engine speed [min <sup>-1</sup> ]	2000-4200	2000-4200
Saw blade diameter (mm)	225	225
Cutting height 90°/45° (mm)	0-70/0-48	0-70/0-48
Inclination (°)	0 [-2]° - 45 [+47]	0 [-2]° - 45 [+47]
Cutting path (mm)	320	320
Table dimensions (mm)	690 x 500	1260 x 910
Table height, legs folded away (mm)	375	375
Table height, legs unfolded (mm)	900	900
Connection Ø d/e (mm)	27/36	27/36
weight (kg)	34,5	66



■ = with MMC electronics

Items Included	RRP in £*	Order no.
angle stop, workpiece holder, operation tool, in a carton		
<b>CS 70 E GB 110V</b>	1.138,00	<b>561257</b>
HW universal saw blade W32, 3 splinterguards, dust extraction set	1.365,60	
<b>CS 70 E-Set GB 110V</b>	2.075,00	<b>561310</b>
fine tooth saw blade HW W48, sliding table, extension table CS 70 VB, extension table CS 70 VL, ripping-cut fence, 3 splinterguards, dust extraction set	2.490,00	
<b>CS 70 EB GB 240V</b>	1.348,00	<b>561254</b>
HW universal saw blade W32, 3 splinterguards, dust extraction set	1.617,60	
<b>CS 70 EB-Set GB 240V</b>	2.075,00	<b>561253</b>
HW universal saw blade W32, sliding table, ripping-cut fence, extension table CS 70 VB, extension table CS 70 VL, 3 splinterguards, dust extraction set	2.490,00	

\* Recommended retail price of manufacturer. Dealer prices may vary.  
Excl. VAT.  
Incl. VAT.

#### System accessories from page 35

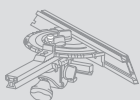

#### Circular saw blades from page 42



### Like a knife through butter.

The size and power of the CS 70 really begins to show when cutting workpieces up to 70 mm thick, both in the workshop and on assembly sites. Comprehensive system accessories allow you to upgrade the CS 70 to a complete sawing station.

# Sawing and oscillating

## Overview of products and applications

Page 27 ————— 27

Powerful, ergonomic, diverse and perfect in the system. With the VECTURO OS 400, you make better cuts everywhere. It offers precise cuts along the scribe mark, perfect cuts for previously defined cutting depths or flush cuts to the wall. But it also offers the decisive precision.

VECTURO OS 400

VECTURO OS 400 Set



### Applications

### Oscillator

#### Sawing

Notches and recesses from sheet material



Cutting sheet material to length



Cutting strip material and slats to length



Flush cutting non-ferrous iron or plastic pipes



Trimming and adapting laminate/parquet flooring



Notching or cutting skirting boards or joining strips to length



Cutting door frame to length



Reworking expansion joints



Cutting out insulating washers in the putty bed



Notching on beams, strip material or boards



Sawing along scribe mark



Sawing to a defined depth



#### Scraping

Removal of old layers and coatings e.g. protective underlay, adhesive residues



Extremely appropriate  Appropriate

#### Technical data

Power (W)	400
Power output (W)	220
Vibration (rpm)	11.000 – 18.500
Amplitude (°)	2
Cable length (m)	4
Weight (kg)	1,55



## VECTURO OS 400

### Equipped with a decisive additional feature: accuracy.

- ▶ Powerful 400-watt motor with electronic speed adjustment switch for consistently fast working progress
- ▶ Ergonomic: slimline housing with rubber-coated handle rests perfectly in the hand, the switches are located in the best position
- ▶ Greater accuracy with the depth stop: simple adjustment without using tools. Accurate sawing along the scribe mark with the positioning aid. Ideal for cut-outs in delicate materials
- ▶ Flexible operation, short set-up times: the VECTURO with plug-it cable is ready to use straightaway. Blades and accessories are replaced without using tools



#### Technical data

Power consumption (W)	400
Power output (W)	220
Vibrations (min <sup>-1</sup> )	11.000-18.500
Amplitude [°]	2
Cable length (m)	4
weight (kg)	1,55



☐ = with electronics

Items Included	RRP in £*	Order no.
universal saw blade USB 78/32/Bi		
<b>OS 400 EQ-Plus GB 240V</b> in a SYSTAINER SYS 2 T-LOC	323,00 387,60	<b>563002</b>
<b>OS 400 EQ-Plus GB 110V</b> in a SYSTAINER SYS 2 T-LOC	323,00 387,60	<b>563004</b>
<b>OS 400 EQ-Set GB 240V</b> wood saw blade HSB 50/35/J, wood saw blade HSB 100/HSC, positioning aid/depth stop set OS-AH/TA Set, in a SYSTAINER SYS 2 T-LOC DF	450,00 540,00	<b>563003</b>
<b>OS 400 EQ-Set GB 110V</b> wood saw blade HSB 50/35/J, wood saw blade HSB 100/HSC, positioning aid/depth stop set OS-AH/TA Set, in a SYSTAINER SYS 2 T-LOC DF	450,00 540,00	<b>563005</b>

\* Recommended retail price of manufacturer. Dealer prices may vary.  
Excl. VAT.  
Incl. VAT.

#### System accessories from page 46

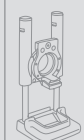

#### Saw blades from page from page 47



### Greater accuracy in every position.

Precise cuts along the scribe mark with the positioning aid, defined cuts with depth stop that can be adjusted without the need for a tool or flush cuts to the wall with a sliding shoe that can also be mounted without a tool. Whether it is wood, non-ferrous metals, composite materials or silicone: Innovative accessories complement the VECTURO to achieve the ultimate precision.

### **The Festool system.**

Because things work better when everything fits together: Festool saws fit perfectly into the system. For example, the guide rails are compatible both with pendulum jigsaws and plunge-cut saws. Bevels can be used for multiple functions and a hand-guided saw can also be used in a semi-stationary configuration with the CMS Compact Module System.



## Sawing and oscillating

Accessories and consumable materials

### Pendulum jigsaws

System accessories	30
Jigsaw blades	38

### Circular saws

System accessories	31
Circular saw blades	42

### Semi-stationary sawing

System accessories	32
Circular saw blades	42

### Oscillators

System accessories	46
Saw blades	47



## Sawing and oscillating

### System accessories

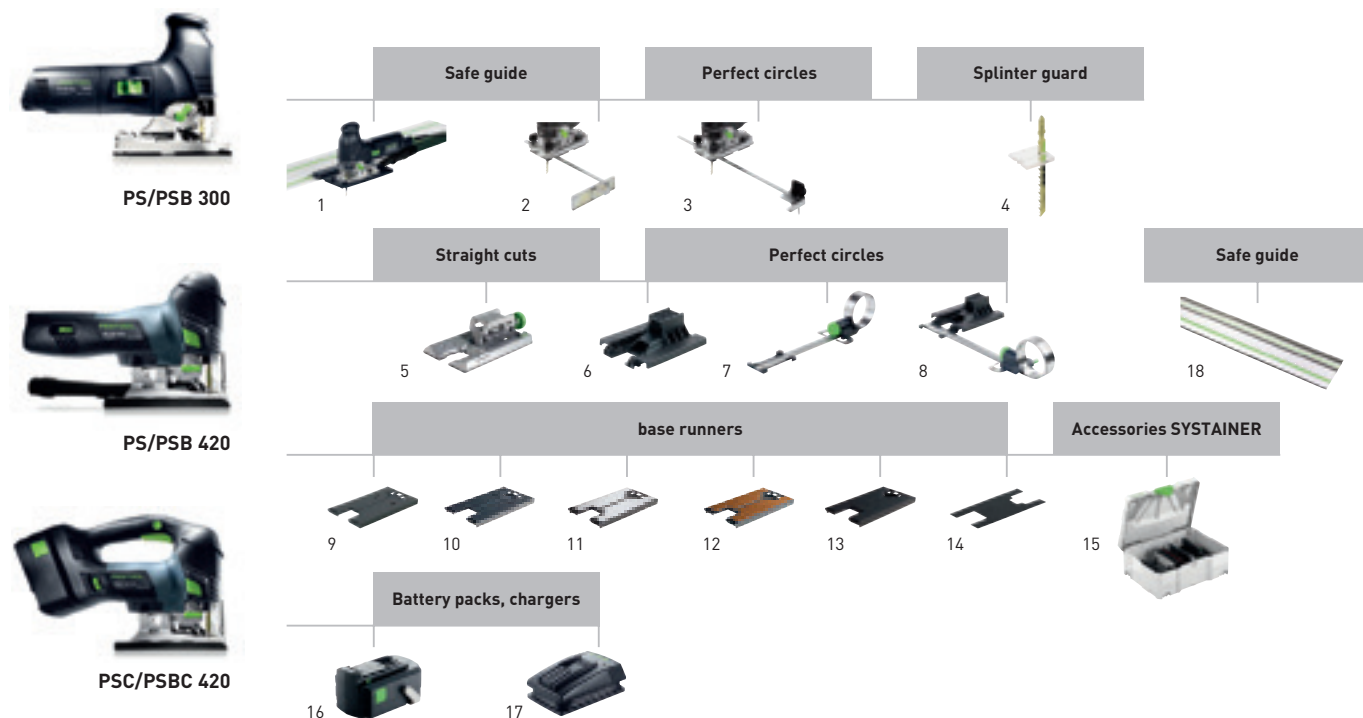

#### Accessories for pendulum jigsaws PS/PSB 300, PS/PSB 420, PSC/PSBC 420

Denomination	Explanation	RRP in £*	Order no.
1 Guide rail adapter FS-PS/PSB 300	for PS 200, PS 300, PSB 300, PS 2, allows use of jigsaws with FS and FS/2 guide systems in self-service display pack	11,30 13,56	490031
2 Parallel side fence PA-PS/PSB 300	for PS 300, PSB 300, PS200, PS2, max. workpiece width 200 mm, in self-service display pack	20,50 24,60	490119
3 Core maker KS-PS/PSB 300	for PS 300, PSB 300, PS200, PS2, circle Ø 130 – 720 mm, in self-service display pack	20,50 24,60	490118
4 Splinter guard SP-PS/PSB 300/5	for PS 300, PSB 300, PS(C) 400/420, PSB(C) 400/420, prevents splintering, qty. in pack 5 piece(s), in self-service display pack	4,90 5,88	490120
Splinter guard SP-PS/PSB 300/20	for PS 300, PSB 300, PS(C) 400/420, PSB(C) 400/420, prevents splintering, qty. in pack 20 piece(s), in self-service display pack	9,35 11,22	490121
5 Angle table WT-PS 420	for PS 400/420, for angled cuts from +45° to -45°, stepless angle adjustment, in self-service display pack	91,20 109,44	496134
6 Adapter table ADT-PS 420	for PS 400/420, for using the PS on the guide rail, for installation in the Compact Module System CMS, in conjunction with circle cutting attachment KS-PS 400, in self-service display pack	11,40 13,68	497303
7 Core maker KS-PS 420	for PS 400/420, circle dia. from 120 mm – 3 m, in conjunction with adapter table ADT-PS 400, in self-service display pack	38,00 45,60	497304
8 Core maker KS-PS 420 Set	for PS 400/420, circle dia. from 120 mm – 3 m, incl. adapter table ADT-PS 420, in self-service display pack	47,70 57,24	497443
9 Base runner LAS-PS 420	for PS(C) 400/420, PSB(C) 400/420, plastic all-round base for wood or similar materials, in self-service display pack	8,00 9,60	497297
10 Base runner LAS-Soft-PS 420	for PS(C) 400/420, PSB(C) 400/420, studded base with optimum sliding properties for wood or similar materials, in self-service display pack	8,00 9,60	497298
11 Base runner LAS-HGW-PS 420	for PS(C) 400/420, PSB(C) 400/420, durable laminated fabric base for wood or similar materials, in self-service display pack	11,90 14,28	497299
12 Base runner LAS-St-PS 420	for PS(C) 400/420, PSB(C) 400/420, for all metallic materials, in self-service display pack	11,90 14,28	497300
13 Base runner LAS-STF-PS 420	for PS(C) 400/420, PSB(C) 400/420, for sensitive surfaces, in self-service display pack	11,90 14,28	497301
14 Spare felt EF-LAS-STF-PS 420	for PS(C) 400/420, PSB(C) 400/420, spare felt for StickFix baseplate LAS-STF-PS 420, in self-service display pack, qty. in pack of 5	6,95 8,34	497444
15 Accessories SYS ZH-SYS-PS 420	for PS 400/420, 5 splinterguards, 3 baseplates, angle table, base maker, StickFix felt, in a SYSTAINER SYS 2 T-LOC	183,30 219,96	497709
16 Battery pack BPC 15 5.2 Ah-Li Ion	lithium-ion spare battery for cordless drills T 15+3, C 15 Li, TI 15 IMPACT and PSC/PSBC 420, Capacity 5,2 Ah, weight 0,580 kg, Voltage 14,4 V, in self-service display pack	67,95 81,54	500434
Battery pack BPC 18 5.2 Ah-Li Ion	lithium-ion spare battery for cordless drills T 18+3, DRC 18/4, PDC 18/4, BHC 18, DWC 18 and PSC/PSBC 420, TSC 55, Capacity 5,2 Ah, weight 0,680 kg, Voltage 18 V, in self-service display pack	76,45 91,74	500435
17 Charger TCL 3 GB 240 V	replacement charger for cordless drills C 12, TDK 12, T 12+3, C 15, TDK 15.6, T 15+3, TI 15, T 18+3, BHC 18, PS(B)C 400/420, TSC 55, DRC 18/4, PDC 18/4, DWC 18-2500 and DWC 18-4500, charger for NiCd, NiMH and li-ion battery packs, charging current 3.0 A, input voltage 220-240 V, in a carton	42,50 51,00	499413
18 Guide rail	see chapter Workplace organisation on page 352		



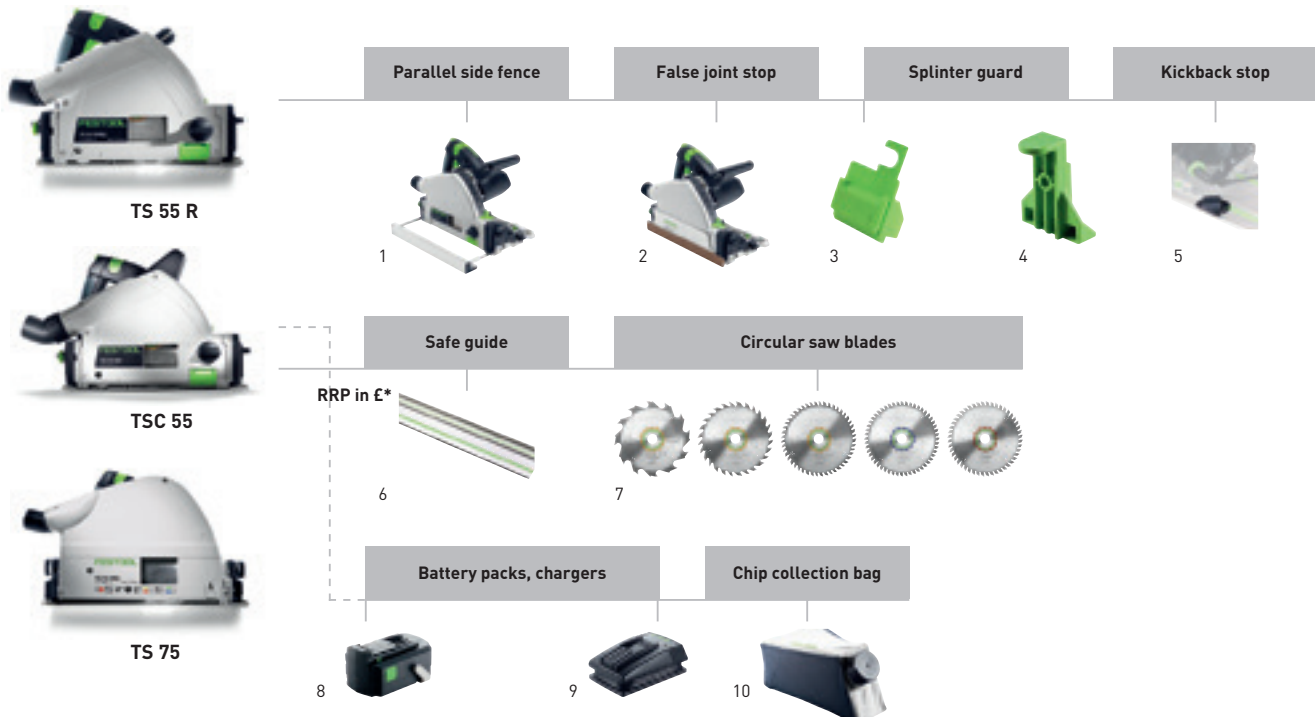

### Accessories for circular saws TS 55, TS 75

Denomination	Explanation	RRP in £*	Order no.
<b>1 Parallel side fence PA-TS 55</b>	for TS 55, TS 55 R, TSC 55, parallel guide, guided on both sides, can also be used as table extension, max. workpiece width 100 mm, in a carton	35,50 42,60	<b>491469</b>
<b>Parallel side fence PA-TS 75</b>	for TS 75, parallel guide, guided on both sides, can also be used as table extension, max. workpiece width 100 mm, in a carton	40,65 48,78	<b>492243</b>
<b>2 Cover ABSA-TS 55</b>	for TS 55, TS 55 R, TSC 55, cover for improved dust extraction, can also be used as false joint set, width of the shadow gap TS 55 15-46 mm, in a carton	35,30 42,36	<b>491750</b>
<b>3 Splinter guard SP-TS 55 R/5</b>	for TS 55 R, TSC 55, for low-splinter cuts to the right of the saw blade, can be used with or without guide rail, qty. in pack 5 piece(s), in self-service display pack	10,20 12,24	<b>499011</b>
<b>4 Splinter guard SP-TS 55/5</b>	for TS 55, TS 75, for low-splinter cuts to the right of the saw blade, can be used with or without guide rail, qty. in pack 5 piece(s), in self-service display pack	10,45 12,54	<b>491473</b>
<b>5 Kickback stop FS-RSP</b>	for TS 55, TS 55 R, TSC 55, TS 75, ATF 55, AP 55, AT 65, AP 65, AP 85, used as a rear and front stop position on guide rail FS/2, can also be used as guide stop, in self-service display pack	12,25 14,70	<b>491582</b>
<b>6 Guide-rails</b>	see chapter Workplace organisation on page 352		
<b>7 Circular saw blades</b>	from page 42		
<b>8 Battery pack BPC 15 5.2 Ah-Li Ion</b>	lithium-ion spare battery for cordless drills T 15+3, C 15 Li, TI 15 IMPACT and PSC/PSBC 420, Capacity 5,2 Ah, weight 0,580 kg, Voltage 14,4 V, in self-service display pack	67,95 81,54	<b>500434</b>
<b>Battery pack BPC 18 5.2 Ah-Li Ion</b>	lithium-ion spare battery for cordless drills T 18+3, DRC 18/4, PDC 18/4, BHC 18, DWC 18 and PSC/PSBC 420, TSC 55, Capacity 5,2 Ah, weight 0,680 kg, Voltage 18 V, in self-service display pack	76,45 91,74	<b>500435</b>
<b>9 Charger TCL 3 GB 240V</b>	replacement charger for cordless drills C 12, TDK 12, T 12+3, C 15, TDK 15.6, T 15+3, TI 15, T 18+3, BHC 18, PS(B)C 400/420, TSC 55, DRC 18/4, PDC 18/4, DWC 18-2500 and DWC 18-4500, charger for NiCd, NiMH and li-ion battery packs, charging current 3.0 A, input voltage 220-240 V, in a carton	42,50 51,00	<b>499413</b>
<b>10 Chip collection bag SB-TSC</b>	for TSC 55, folds down for space-saving transportation, with dust cap, for all woods, in self-service display pack	25,45 30,54	<b>500393</b>

## Sawing and oscillating

### System accessories

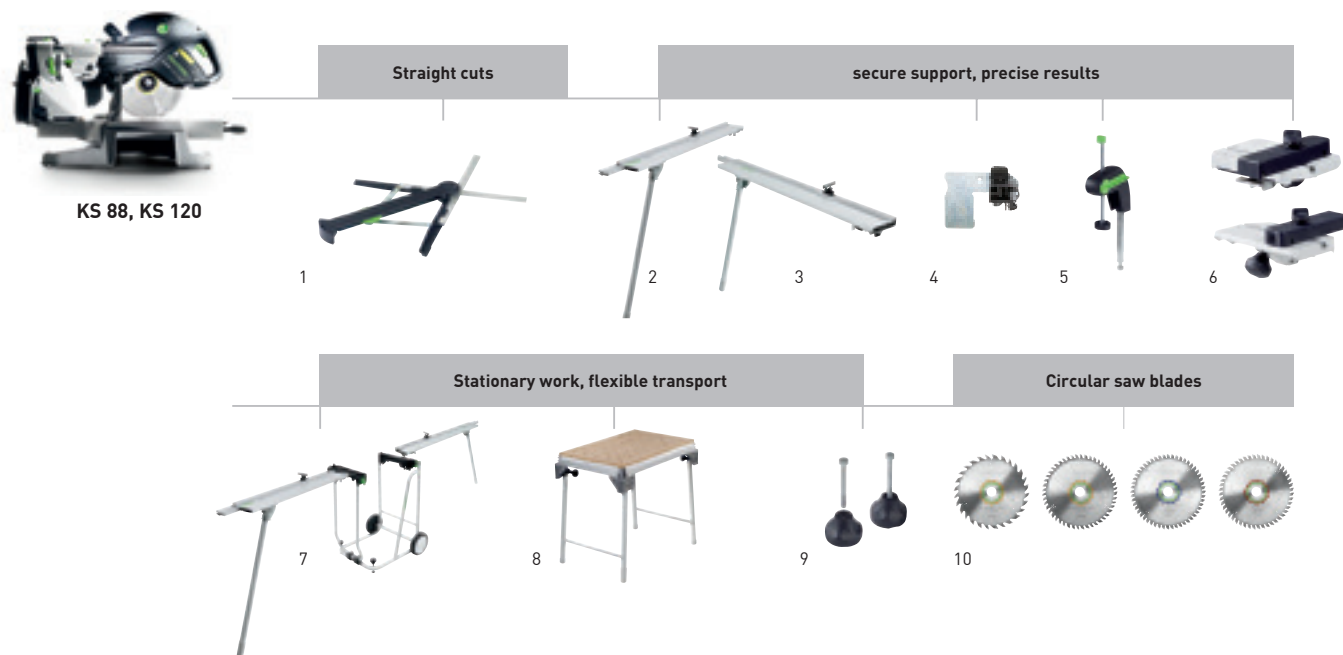

#### Accessories for sliding compound mitre saws KAPEX KS 88, KS 120

Denomination	Explanation	RRP in £*	Order no.
1 Bevel SM-KS 120	for KS 120, bevel for transferring angles to the circular cross-cut saw, for interior and exterior angles, dissecting angle is generated automatically, no calculations, in self-service display pack	84,45 101,34	494370
2 Trimming attachment KA-UG-L	for KS 120, KS 88, measurement scale, adjustable stop, telescopic slide-out scale, fold-out pedestal and carry case, length, ext.arm (w/out teles.) 1480 mm, max. meas. length 2400 mm, weight 4,6 kg, in a carton	174,50 209,40	497353
Trimming attachment KA-KS-L	for KS 120, KS 88, simple extraction and rolling out of measuring tape thanks to telescopic mechanism, only compatible with crown stop AB-KS, adjustable stop, stop, measurement scale, adjustable legs, trimming stop, Total length 1280 – 2070 mm, cutting length 380 – 2300 mm, in a carton	248,30 297,96	495969
3 Trimming attachment KA-UG-R	for KS 120, KS 88, measurement scale, adjustable stop, telescopic slide-out scale, fold-out pedestal and carry case, length, ext.arm (w/out teles.) 1480 mm, max. meas. length 2400 mm, weight 4,6 kg, in a carton	174,50 209,40	497352
Trimming attachment KA-KS-R	for KS 120, KS 88, simple extraction and rolling out of measuring tape thanks to telescopic mechanism, only compatible with crown stop AB-KS, adjustable stop, stop, measurement scale, adjustable legs, trimming stop, Total length 1280 – 2070 mm, cutting length 380 – 2300 mm, in a carton	248,30 297,96	495968
4 Adjustable stop KA-AR	for CS 50, CS 70, for positioning workpieces on trimming attachment CS 70 KA, Basis KA 100/200 and KA-KS L/R, in self-service display pack	25,40 30,48	488560
5 Terminal KL-KS	for KS 120, KS 88, workpiece clamp for securing workpieces, can be used on the left or right, included in the contents of the KS 120, maximum height of workpiece 120 mm, in self-service display pack	38,00 45,60	494391
6 Crown stop AB-KS	for KS 120, KS 88, stop for positioning crown mouldings at an angle, only compatible with KA-KS, also used for securing the table extension KA-KS, crown moulding stop with table widener, in self-service display pack	52,10 62,52	494369
7 Underframe UG-KA-Set	for KS 120, KS 88, simple folding in for transport, (KA-UG-R and KA-UG-L trimming attachments incl. in the contents), transport rollers, measurement scale, adjustable stop, telescopic slide-out scale, fold-out pedestal and carry case, work height 900 mm, weight 21 kg, in a carton	546,30 655,56	497354
Underframe UG-KAPEX	for KS 120, KS 88, simple folding in for transport, transport rollers, work height 900 mm, weight 10,1 kg, in a carton	286,00 343,20	497351
Trimming attachment KA-UG-L	for KS 120, KS 88, measurement scale, adjustable stop, telescopic slide-out scale, fold-out pedestal and carry case, length, ext.arm (w/out teles.) 1480 mm, max. meas. length 2400 mm, weight 4,6 kg, in a carton	174,50 209,40	497353
Trimming attachment KA-UG-R	for KS 120, KS 88, measurement scale, adjustable stop, telescopic slide-out scale, fold-out pedestal and carry case, length, ext.arm (w/out teles.) 1480 mm, max. meas. length 2400 mm, weight 4,6 kg, in a carton	174,50 209,40	497352
8 Multifunction table MFT KAPEX	used as a base frame for the KAPEX, clamping kit SZ-KS required for fixing, table with perforated top and foldaway legs, table dimensions 869 x 581 mm, work height/with foldaway legs 180 mm, working height with legs 790 mm, load capacity 120 kg, weight 19 kg, in a carton	292,00 350,40	495465
9 Clamping kit SZ-KS	for KS 120, KS 88, for tightening the KS 88/120 on the multifunction table, 2 pieces, in self-service display pack	10,85 13,02	494693
10 Circular saw blades	from page 42		

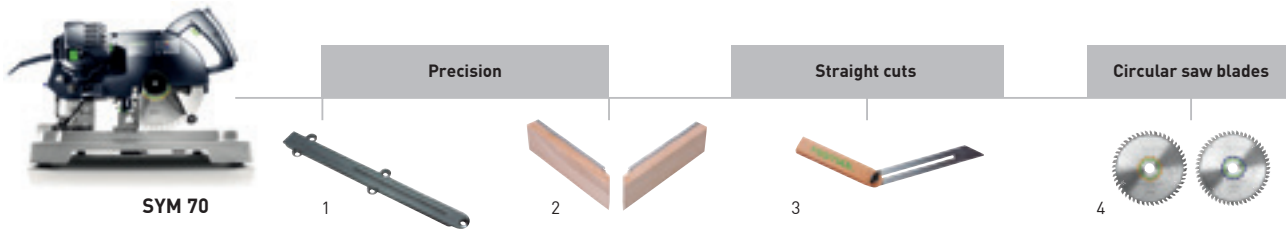

#### Accessories for SYMMETRIC compound mitre saw SYM 70

Denomination	Explanation	RRP in £*	Order no.
1 <b>Table top insert TE-SYM 70</b>	Table top insert can be replaced when worn, for SYMMETRIC 70 E, qty. in pack 3 piece(s), in self-service display pack	10,85 13,02	<b>491054</b>
2 <b>Additional stop ZA-SYM 70 E</b>	for SYMMETRIC 70 E, for cutting undercut strips, qty. in pack 2 piece(s), in a carton	30,90 37,08	<b>491886</b>
3 <b>Precision adjustable square SM-SYM 70</b>	for SYMMETRIC 70 E, angles can be transferred directly from the wall/workpiece to the guide rail, no need to measure with additional protractor, in self-service display pack	22,65 27,18	<b>491053</b>
4 <b>Circular saw blades</b>	from page 42		

# Sawing and oscillating

## System accessories

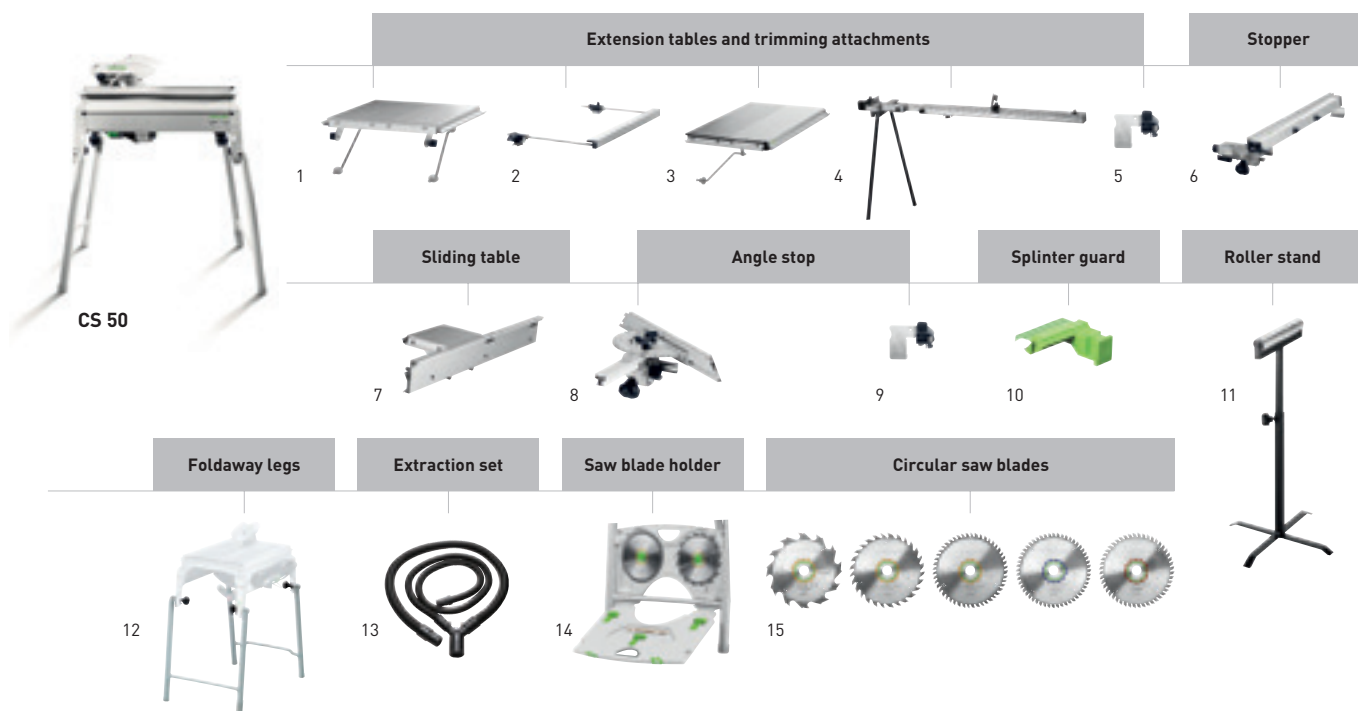

### Accessories for trimming saw CS 50

Denomination	Explanation	RRP in £*	Order no.
1 Extension table VL	for CS 50, CMS-GE, simple fitting, folds away, enlarges the support surface by 405 mm, for safe support of long workpieces when sawing to width, dimensions length x width 375 x 454 mm, in a carton	165,05 198,06	492092
2 Support AF	for CS 50, CMS-GE, support for both side use, supports workpieces while cutting, enlarges the support surface by 300 mm, dimensions length x width 662 x 390 mm, in a carton	70,90 85,08	492242
3 Extension table VB	for CS 50, with adjustable dimension scale, extends the support area by 410 mm, max. working width longitudinal 610 mm, dimensions length x width 664 x 438 mm, in a carton	212,25 254,70	492090
4 Trimming attachment CS 70 KA	for CS 70 and CS 50, removable, with support, bearing surface, tape measure and adjustable stop, simple extraction and rolling out of measuring tape thanks to telescopic mechanism, Length 1200 – 2050 mm, in a carton	245,50 294,60	488063
5 Adjustable stop KA-AR	for CS 50, CS 70, for positioning workpieces on trimming attachment CS 70 KA, Basis KA 100/200 and KA-KS L/R, in self-service display pack	25,40 30,48	488560
6 Stopper LA-CS 50/CMS	for CS 50, CMS-GE, with fine adjustment and rear clamp, can be operated from front, with moveable stop profile for precise and safe longitudinal cuts, in a carton	171,00 205,20	492095
7 Sliding table ST	for CS 50, CMS-GE, max. working width for trimming cuts 830 mm, in a carton	235,80 282,96	492100
8 Angle stop WA	for CS 70, CS 50, CMS-GE, for work requiring 2 stops, in a carton	114,90 137,88	488451
9 Adjustable stop WA-AR	for CS 50, CS 70, to stop workpieces on trimming attachment CS 70 WA, CS 50 WA and Basis WRA 500, in self-service display pack	25,40 30,48	491712
10 Splinter guard CS 50 SP/10	for CS 50, for splinter-free cut edges on both sides, qty. in pack 10 piece(s), in self-service display pack	13,65 16,38	492241
11 Roller stand RB	for all semi-stationary devices (CS/KS/CMS), to use longer workpieces for longitudinal sections and cross sections and cutting and grinding work, may be used with the CS 50, CS 70, CB 120, Basis Plus System, CMS-GE, multifunction table, height adjustable 630 – 1000 mm, in a carton	125,75 150,90	488711
12 Foldaway legs CS 50 KB	for CS 50, makes two work heights possible, foldaway legs for the extension of the CS 50 floor version, in a carton	141,60 169,92	492245
13 Dust extraction set CS 70 AB	for CT/CTM, can be used with Basis, CS 70, CS 50 and CMS, comprising: dust extraction hose D27x2.0 m, dust extraction hose D36x1.0 m, Y terminal, (not compatible with CTL MINI/MIDI), Diameter 27/36 mm, in a carton	71,95 86,34	488292
14 Saw blade holder SGA	for CS 50, CMS-GE, for safe and space-saving storage of up to 4 saw blades (max. Ø 190 mm) and up to 3 splinterguards (not included in contents), in a carton	34,30 41,16	492228
15 Circular saw blades	from page 42		

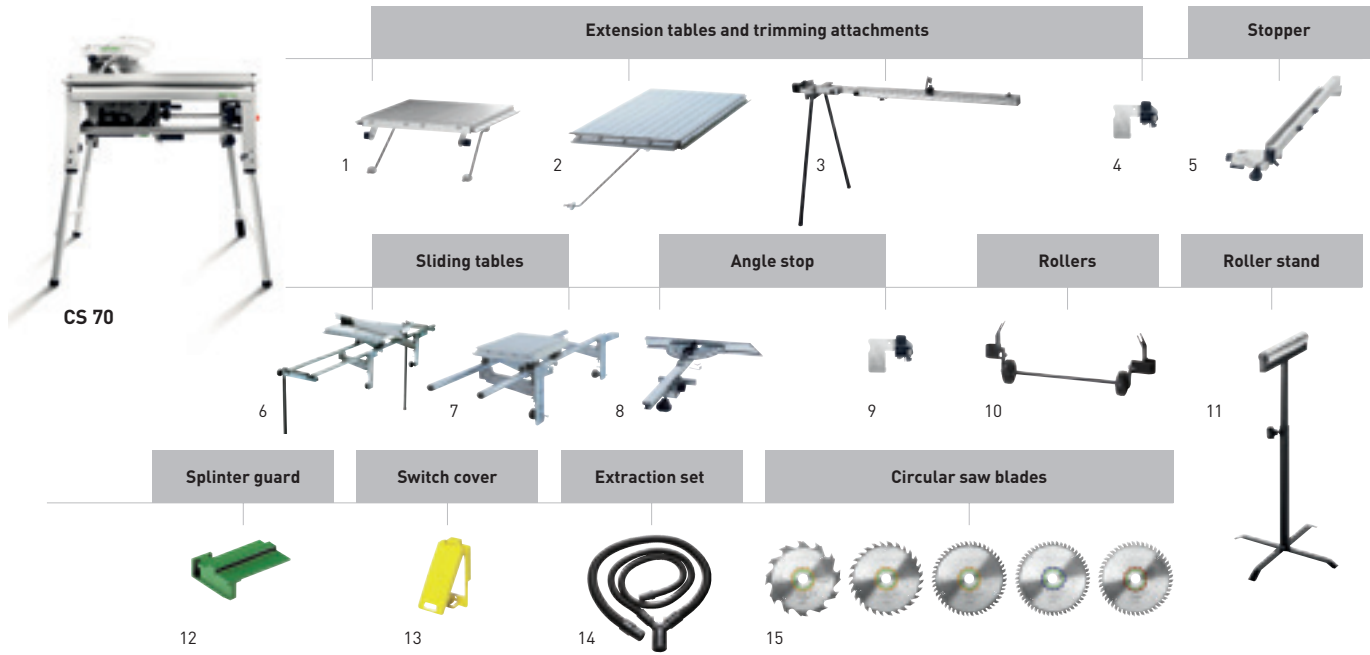

### Accessories for trimming saw CS 70

Denomination	Explanation	RRP in £*	Order no.
1 Extension table CS 70 VL	for CS 70, simple fitting, folds away, for safe support of long workpieces when sawing to width, extends the support area by 580 mm, dimensions length x width 525 x 522 mm, in a carton	202,10 242,52	488061
2 Extension table CS 70 VB	for CS 70, with adjustable dimension scale, easy and quick to assemble and dismantle, for safe and precise width sawing, extends the support area by 411 mm, max. working width longitudinal 680 mm, dimensions length x width 773 x 435 mm, in a carton	284,20 341,04	488060
3 Trimming attachment CS 70 KA	for CS 70 and CS 50, removable, with support, bearing surface, tape measure and adjustable stop, simple extraction and rolling out of measuring tape thanks to telescopic mechanism, Length 1200 – 2050 mm, in a carton	245,50 294,60	488063
4 Adjustable stop KA-AR	for CS 50, CS 70, for positioning workpieces on trimming attachment CS 70 KA, Basis KA 100/200 and KA-KS L/R, in self-service display pack	25,40 30,48	488560
5 Stopper CS 70 LA	for CS 70, MFT/3-VL, with fine adjustment and rear clamp, can be operated from front, with moveable stop profile for precise and safe longitudinal cuts, in a carton	199,45 239,34	488062
6 Sliding table CS 70 ST	for CS 70, for sawing boards, easy and quick to assemble and dismantle, 2 supporting legs, stop ruler with additional clamp, max. working width for trimming cuts 920 mm, in a carton	662,95 795,54	488059
7 Sliding table CS 70 ST 650	for CS 70, easy and quick to assemble and dismantle, max. working width for trimming cuts 650 mm, in a carton	350,25 420,30	490312
8 Angle stop WA	for CS 70, CS 50, CMS-GE, for work requiring 2 stops, in a carton	114,90 137,88	488451
9 Adjustable stop WA-AR	for CS 50, CS 70, to stop workpieces on trimming attachment CS 70 WA, CS 50 WA and Basis WRA 500, in self-service display pack	25,40 30,48	491712
10 Transport rollers CS 70 TR	for CS 70, can be fitted to foldaway legs, for simple and comfortable transportation, in a carton	71,95 86,34	488064
11 Roller stand RB	for all semi-stationary devices (CS/KS/CMS), to use longer workpieces for longitudinal sections and cross sections and cutting and grinding work, may be used with the CS 50, CS 70, CB 120, Basis Plus System, CMS-GE, multifunction table, height adjustable 630 – 1000 mm, in a carton	125,75 150,90	488711
12 Splinter guard CS 70 SP /10	for CS 70, for splinter-free cut edges on both sides, qty. in pack 10 piece(s), in self-service display pack	13,65 16,38	490340
13 Switch cover SAB	for PRECISIO CS 70 and Basis basic unit, can be retrofitted on base, padlock serves as a starting lockout, in a bag	12,45 14,94	488065
14 Dust extraction set CS 70 AB	for CT/CTM, can be used with Basis, CS 70, CS 50 and CMS, comprising: dust extraction hose D27x2.0 m, dust extraction hose D36x1.0 m, Y terminal, (not compatible with CTL MINI/MIDI), Diameter 27/36 mm, in a carton	71,95 86,34	488292
15 Circular saw blades	from page 42		

## Sawing and oscillating

### Saw blades

#### Quality cuts better.

#### Festool saw blades.

Durability and precision under the toughest conditions. Adapted to the application and material.

Jigsaw blades manufactured from temperature-resistant, hard-wearing HS bimetal. Circular saw blades

made from steel manufactured using laser technology and saw teeth made from fine-grain carbide.

After all, you can only achieve a perfect cut when the saw blade is as good as the machine.



#### Colour code



##### Wood/Soft plastics

Circular saw and jigsaw blades perfectly adapted to hardwood, softwood, solid wood and building panels are available.



##### Plastics/Mineral materials

The fine-grain carbide used in saw blades guarantees perfect cuts in coated panels and mineral materials. Jigsaw blades made from bimetal are ideal for plastics, acrylic glass and composite materials.



##### Aluminium

Blue circular saw and jigsaw blades were designed for aluminium profiles and plates.



##### Steel/Sandwich panels

The slightly chamfered teeth of the circular saw blades are suitable for sawing cable ducts or steel sheets and profiles.



##### Building materials

The material and teeth of the circular and jigsaw blades are both designed specially for working with abrasive materials.

**Perfect adaptation**

The saw blades for circular saws and jigsaws are manufactured from high-quality metal for perfect cuts and a long service life. Cutting angle and tooth shapes are adapted to the application and machine.

**Long-term precision**

Diamond wheels lend the teeth of the circular saw blades a perfect finish, guaranteeing a long useful life and excellent cutting results without leaving you with extensive rework.

**Simple selection**

The practical colour coding system helps you quickly locate the correct circular saw blade or jigsaw blade for the respective application.

**Minimum heat generation**

Slow heating of the circular saw blades through laser-cut and thermally adjusted blade cores.

**Rapid cutting progress**

High-quality steel and optimised expansion slots of the circular saw blades for a smooth, safe cutting progress.

**Robust quality**

Long service life and excellent sharpening properties of saw teeth of the circular saw blades guarantee an excellent price/performance ratio.

**Tooth shapes****Alternate top bevel saw blade**

The teeth on this blade slope to the left and right and cut alternately. The alternate top bevel saw blade is a universal blade for all types of wood.

**Triple chip grind saw blade**

With alternating trapezoidal and flat teeth, this blade is used for cutting aluminium, hard plastic and materials with hard coatings.

**Flat tooth saw blade**

The edges of the teeth are straight, not sloping. Each tooth cuts in the same way. This saw blade is used for cutting steel.

W/PW

TF

F

# Sawing and oscillating

## Jigsaw blades

### Tooth pitch, type and material



cross-set teeth for quick cuts



conically ground blades for clean cuts



HCS tool steel: standard quality for all types of wood



HS bimetal: resistant to high temperatures and hard-wearing

### Saw blade features



carbide: resistant to high temperatures and hard-wearing



brazed carbide grit, fine



coarse or fine saw blade. Rule of thumb: at least 3 teeth should be engaged



serrated blade, milled teeth

### Universal saw blade

		Length of cutting blade	Pitch	Maximum work-piece thickness	qty. in pack	RRP in £*	Order no.
	S 75/4/5	75 mm	4 mm	55 mm	5 piece(s)	6,65 7,98	486546
	S 75/4/25	75 mm	4 mm	55 mm	25 piece(s)	28,95 34,74	486962
	S 75/4/100	75 mm	4 mm	55 mm	100 piece(s)	97,60 117,12	493522
	S 105/4/5	105 mm	4 mm	85 mm	5 piece(s)	10,95 13,14	486547

### Fine-cut saw blade

		Length of cutting blade	Pitch	Maximum work-piece thickness	qty. in pack	RRP in £*	Order no.
	S 75/2,5/5	75 mm	2,5 mm	55 mm	5 piece(s)	9,35 11,22	486548
	S 75/2,5/25	75 mm	2,5 mm	55 mm	25 piece(s)	41,25 49,50	486963
	S 75/2,5/100	75 mm	2,5 mm	55 mm	100 piece(s)	133,25 159,90	493521
	HS 75/2,5 BI/5	75 mm	2,5 mm	55 mm	5 piece(s)	17,00 20,40	490178
	HS 75/2,5 BI R/5	75 mm	2,5 mm	55 mm	5 piece(s)	16,50 19,80	493570

### Special wood saw blade

		Length of cutting blade	Pitch	Maximum work-piece thickness	qty. in pack	RRP in £*	Order no.
	S 75/4 FS/5	75 mm	4 mm	55 mm	5 piece(s)	12,70 15,24	486549
	S 75/4 FS/20	75 mm	4 mm	55 mm	20 piece(s)	45,05 54,06	490256
	S 75/4 FS/100	75 mm	4 mm	55 mm	100 piece(s)	170,90 205,08	493523
	S 75/4 FSG 5X	75 mm	4 mm	55 mm	5 piece(s)	15,75 18,90	499476
	S 75/4 FSG 20X	75 mm	4 mm	55 mm	20 piece(s)	55,25 66,30	499441
	S 105/4 FSG 5X	105 mm	4 mm	85 mm	5 piece(s)	20,90 25,08	499477
	S 105/4 FSG 20X	105 mm	4 mm	85 mm	20 piece(s)	70,95 85,14	499475
	S 145/4 FSG 5X	145 mm	4 mm	120 mm	5 piece(s)	24,50 29,40	499478





Softwood, hardwood



Untreated chipboard



Coated chipboard,  
veneered blockboard



Soft plastics



Acrylic glass



	<input checked="" type="checkbox"/>	<input checked="" type="checkbox"/>	<input checked="" type="checkbox"/>		
	<input checked="" type="checkbox"/>	<input checked="" type="checkbox"/>	<input checked="" type="checkbox"/>		
	<input checked="" type="checkbox"/>	<input checked="" type="checkbox"/>	<input checked="" type="checkbox"/>		
	<input checked="" type="checkbox"/>	<input checked="" type="checkbox"/>	<input checked="" type="checkbox"/>		

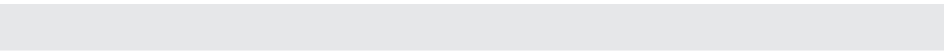

	<input checked="" type="checkbox"/>		<input checked="" type="checkbox"/>	<input checked="" type="checkbox"/>	<input checked="" type="checkbox"/>
	<input checked="" type="checkbox"/>		<input checked="" type="checkbox"/>	<input checked="" type="checkbox"/>	<input checked="" type="checkbox"/>
	<input checked="" type="checkbox"/>		<input checked="" type="checkbox"/>	<input checked="" type="checkbox"/>	<input checked="" type="checkbox"/>
	<input checked="" type="checkbox"/>		<input checked="" type="checkbox"/>	<input checked="" type="checkbox"/>	<input checked="" type="checkbox"/>
	<input checked="" type="checkbox"/>		<input checked="" type="checkbox"/>	<input checked="" type="checkbox"/>	<input checked="" type="checkbox"/>

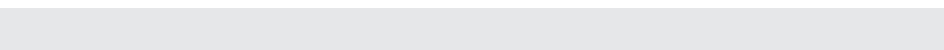

	<input checked="" type="checkbox"/>	<input checked="" type="checkbox"/>	<input checked="" type="checkbox"/>		
	<input checked="" type="checkbox"/>	<input checked="" type="checkbox"/>	<input checked="" type="checkbox"/>		
	<input checked="" type="checkbox"/>	<input checked="" type="checkbox"/>	<input checked="" type="checkbox"/>		
	<input checked="" type="checkbox"/>	<input checked="" type="checkbox"/>	<input checked="" type="checkbox"/>		
	<input checked="" type="checkbox"/>	<input checked="" type="checkbox"/>	<input checked="" type="checkbox"/>		
	<input checked="" type="checkbox"/>	<input checked="" type="checkbox"/>	<input checked="" type="checkbox"/>		
	<input checked="" type="checkbox"/>	<input checked="" type="checkbox"/>	<input checked="" type="checkbox"/>		
	<input checked="" type="checkbox"/>	<input checked="" type="checkbox"/>	<input checked="" type="checkbox"/>		

# Sawing and oscillating

## Jigsaw blades

### Tooth pitch, type and material



cross-set teeth for quick cuts



conically ground blades for clean cuts



HCS tool steel: standard quality for all types of wood



HS bimetal: resistant to high temperatures and hard-wearing

### Saw blade features



carbide: resistant to high temperatures and hard-wearing



brazed carbide grit, fine



coarse or fine saw blade. Rule of thumb: at least 3 teeth should be engaged



serrated blade, milled teeth

### Curve saw blade

		Length of cutting blade	Pitch		Maximum work-piece thickness	qty. in pack	RRP in £*	Order no.
	S 75/4 K/5	75 mm	4 mm		55 mm	5 piece(s)	8,10 9,72	<b>486563</b>
	S 75/4 K/25	75 mm	4 mm		55 mm	25 piece(s)	35,30 42,36	<b>486965</b>
	HS 75/3 BI-FC/5	75 mm	3 mm		30 mm	5 piece(s)	17,00 20,40	<b>496395</b>
	S 50/1,4 K/5	50 mm	1,4 mm		30 mm	5 piece(s)	6,75 8,10	<b>486564</b>
	HS 75/4 BI/5	75 mm	4 mm		55 mm	5 piece(s)	17,00 20,40	<b>486553</b>

### Plastic saw blade

		Length of cutting blade	Pitch		Maximum work-piece thickness	qty. in pack	RRP in £*	Order no.
	HS 75/3 BI/5	75 mm	3 mm		55 mm	5 piece(s)	17,00 20,40	<b>486554</b>

### Metal saw blade

		Length of cutting blade	Pitch		Maximum work-piece thickness	qty. in pack	RRP in £*	Order no.
	HS 60/1,2 BI/5	60 mm	1,2 mm		30 mm	5 piece(s)	12,10 14,52	<b>486556</b>
	HS 60/1,2 BI/25	60 mm	1,2 mm		30 mm	25 piece(s)	53,85 64,62	<b>488016</b>
	HS 60/1,4 BI VA/5	60 mm	1,4 mm		10 mm	5 piece(s)	12,35 14,82	<b>490181</b>
	HS 105/1,2 BI/5	105 mm	1,2 mm		85 mm	5 piece(s)	17,00 20,40	<b>486558</b>
	HS 155/1,2 BI/5	155 mm	1,2 mm		130 mm	5 piece(s)	22,25 26,70	<b>490180</b>
	HS 60/2 BI/5	60 mm	2 mm		30 mm	5 piece(s)	12,10 14,52	<b>486557</b>
	HS 105/2 BI/5	105 mm	2 mm		85 mm	5 piece(s)	17,00 20,40	<b>486559</b>

### Special saw blade

		Length of cutting blade	Pitch		Maximum work-piece thickness	qty. in pack	RRP in £*	Order no.
	HM 75/4,5	75 mm	4,5 mm		50 mm	1 piece(s)	15,35 18,42	<b>486561</b>
	HM 105/4,5	105 mm	4,5 mm		80 mm	1 piece(s)	18,45 22,14	<b>486560</b>
	R 54 G Riff	54 mm	- mm		30 mm	1 piece(s)	6,65 7,98	<b>486562</b>















### Insulating material saw blade

		Length of cutting blade			Maximum work-piece thickness	qty. in pack	RRP in £*	Order no.
	S 155/W/3	155 mm			130 mm	3 piece(s)	12,10 14,52	<b>493656</b>

# Sawing and oscillating

## Jigsaw blades

01

														
Softwood, hardwood	Untreated chipboard	Coated chipboard, veneered blockboard	Laminated boards	Reinforced/fibre-reinforced plastics	Soft plastics	Acrylic glass	Composite materials	Non-ferrous metals	Aluminium, steel sheets and profiles	Sandwich material / boards	Stainless steel	Iron, steel	Glass, tiles, ceramics	Polystyrene, cardboard, insulating materials

<input checked="" type="checkbox"/>	<input checked="" type="checkbox"/>	<input checked="" type="checkbox"/>													
<input checked="" type="checkbox"/>	<input checked="" type="checkbox"/>	<input checked="" type="checkbox"/>													
<input checked="" type="checkbox"/>		<input checked="" type="checkbox"/>													
<input checked="" type="checkbox"/>	<input checked="" type="checkbox"/>	<input checked="" type="checkbox"/>													
<input checked="" type="checkbox"/>	<input checked="" type="checkbox"/>	<input checked="" type="checkbox"/>	<input checked="" type="checkbox"/>												

						<input checked="" type="checkbox"/>	<input checked="" type="checkbox"/>	<input checked="" type="checkbox"/>							
--	--	--	--	--	--	-------------------------------------	-------------------------------------	-------------------------------------	--	--	--	--	--	--	--











									<input checked="" type="checkbox"/>	<input checked="" type="checkbox"/>					
									<input checked="" type="checkbox"/>	<input checked="" type="checkbox"/>					
									<input checked="" type="checkbox"/>	<input checked="" type="checkbox"/>					
											<input checked="" type="checkbox"/>				
									<input checked="" type="checkbox"/>	<input checked="" type="checkbox"/>	<input checked="" type="checkbox"/>				
									<input checked="" type="checkbox"/>	<input checked="" type="checkbox"/>		<input checked="" type="checkbox"/>			

		<input checked="" type="checkbox"/>		<input checked="" type="checkbox"/>	<input checked="" type="checkbox"/>			<input checked="" type="checkbox"/>					<input checked="" type="checkbox"/>		
		<input checked="" type="checkbox"/>		<input checked="" type="checkbox"/>	<input checked="" type="checkbox"/>			<input checked="" type="checkbox"/>						<input checked="" type="checkbox"/>	
				<input checked="" type="checkbox"/>	<input checked="" type="checkbox"/>			<input checked="" type="checkbox"/>						<input checked="" type="checkbox"/>	<input checked="" type="checkbox"/>

															<input checked="" type="checkbox"/>
--	--	--	--	--	--	--	--	--	--	--	--	--	--	--	-------------------------------------

# Sawing and oscillating

## Circular saw blades

Colour code	Material	Recommended speed range
		<b>3-6</b>
		<b>3-5</b>
		<b>1-6</b>
		<b>Fe</b>
		<b>Al</b>

### Standard saw blade

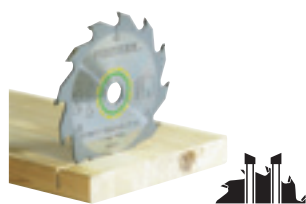

	Diameter	Cutting width	Hole Ø	No. of teeth	Chip angle	Tooth shape	RRP in £*	Order no.
160x2,2x20 W18	160 mm	2,2 mm	20 mm	18	25 °	W	33,05 39,66	<b>768129</b>
190x2,8x30 W16	190 mm	2,8 mm	30 mm	16	20 °	W	43,30 51,96	<b>486296</b>
210x2,6x30 W18	210 mm	2,6 mm	30 mm	18	20 °	W	48,80 58,56	<b>493197</b>
240x2,8x30 W22	240 mm	2,8 mm	30 mm	22	20 °	W	55,40 66,48	<b>437042</b>
350x3,5x30 W24	350 mm	3,5 mm	30 mm	24	10 °	W	75,45 90,54	<b>769667</b>

### Panther saw blade

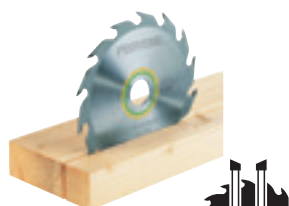

	Diameter	Cutting width	Hole Ø	No. of teeth	Chip angle	Tooth shape	RRP in £*	Order no.
160x2,2x20 PW12	160 mm	2,2 mm	20 mm	12	20 °	PW	43,30 51,96	<b>496301</b>
190x2,6 FF PW16	190 mm	2,6 mm	FF **	16	28 °	PW	55,70 66,84	<b>492049</b>
190x2,8x30 PW14	190 mm	2,8 mm	30 mm	14	37 °	PW	55,80 66,96	<b>486298</b>
210x2,6x30 PW16	210 mm	2,6 mm	30 mm	16	28 °	PW	61,70 74,04	<b>493196</b>
225x2,6x30 PW18	225 mm	2,6 mm	30 mm	18	28 °	PW	61,90 74,28	<b>496303</b>

### Universal saw blade

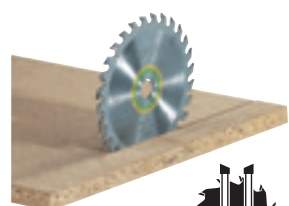

	Diameter	Cutting width	Hole Ø	No. of teeth	Chip angle	Tooth shape	RRP in £*	Order no.
160x2,2x20 W28	160 mm	2,2 mm	20 mm	28	15 °	W	49,40 59,28	<b>496302</b>
190x2,6 FF W32	190 mm	2,6 mm	FF **	32	10 °	W	61,70 74,04	<b>492048</b>
190x2,8x30 W32	190 mm	2,8 mm	30 mm	32	15 °	W	61,90 74,28	<b>490517</b>
210x2,4x30 W36	210 mm	2,4 mm	30 mm	36	15 °	W	63,75 76,50	<b>493198</b>
225x2,6x30 W32	225 mm	2,6 mm	30 mm	32	20 °	W	61,90 74,28	<b>488288</b>
260x2,5x30 W60	260 mm	2,5 mm	30 mm	60	-5 °	W	118,40 142,08	<b>494604</b>

### Fine tooth saw blade

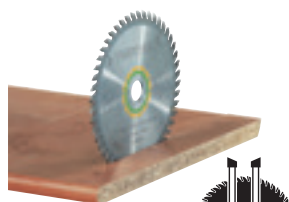

	Diameter	Cutting width	Hole Ø	No. of teeth	Chip angle	Tooth shape	RRP in £*	Order no.
160x2,2x20 W48	160 mm	2,2 mm	20 mm	48	5 °	W	61,60 73,92	<b>491952</b>
190x2,4 FF W48	190 mm	2,4 mm	FF **	48	8 °	W	74,20 89,04	<b>492050</b>
190x2,8x30 W48	190 mm	2,8 mm	30 mm	48	8 °	W	74,10 88,92	<b>486297</b>
210x2,4x30 W52	210 mm	2,4 mm	30 mm	52	5 °	W	86,50 103,80	<b>493199</b>
216x2,3x30 W48	216 mm	2,3 mm	30 mm	48	-5 °	W	89,95 107,94	<b>491050</b>
225x2,6x30 W48	225 mm	2,6 mm	30 mm	48	10 °	W	86,85 104,22	<b>488289</b>
240x2,8x30 W48	240 mm	2,8 mm	30 mm	48	10 °	W	98,75 118,50	<b>435187</b>
260x2,5x30 W80	260 mm	2,5 mm	30 mm	80	-5 °	W	142,00 170,40	<b>494605</b>

#### Recommended speed range

Sawing and oscillating  
Circular saw blades

Coated panels, laminate panels
Veneered panels, parquet
Soft plastic, soft PVC
Hard plastic, hard PVC
Solid wood cross sections, blockboard
Rip cuts in solid wood
MDF and plasterboard, soft cement panels
Plywood, multiplex/multilayered wood
Acrylic glass
MDF - Medium-density fibreboard
HDF - High-density fibreboard
Untreated chipboard
Rockwool board
Dry plaster material

Processed material

			<input checked="" type="radio"/>			<input type="radio"/>	<input type="radio"/>			<input type="radio"/>		
			<input checked="" type="radio"/>			<input type="radio"/>	<input type="radio"/>			<input type="radio"/>		
			<input checked="" type="radio"/>			<input type="radio"/>	<input type="radio"/>			<input type="radio"/>		
			<input checked="" type="radio"/>			<input type="radio"/>	<input type="radio"/>			<input type="radio"/>		
					<input checked="" type="radio"/>	<input type="radio"/>	<input type="radio"/>			<input type="radio"/>		

					<input type="radio"/>	<input checked="" type="radio"/>						
					<input type="radio"/>	<input checked="" type="radio"/>						
					<input type="radio"/>	<input checked="" type="radio"/>						
					<input type="radio"/>	<input checked="" type="radio"/>						
					<input type="radio"/>	<input checked="" type="radio"/>						

		<input type="radio"/>	<input type="radio"/>	<input type="radio"/>	<input checked="" type="radio"/>	<input type="radio"/>	<input checked="" type="radio"/>	<input checked="" type="radio"/>		<input checked="" type="radio"/>	<input checked="" type="radio"/>	<input checked="" type="radio"/>	<input type="radio"/>	<input type="radio"/>
		<input type="radio"/>	<input type="radio"/>	<input type="radio"/>	<input checked="" type="radio"/>	<input type="radio"/>	<input checked="" type="radio"/>	<input checked="" type="radio"/>		<input checked="" type="radio"/>	<input checked="" type="radio"/>	<input checked="" type="radio"/>	<input type="radio"/>	<input type="radio"/>
		<input type="radio"/>	<input type="radio"/>	<input type="radio"/>	<input checked="" type="radio"/>	<input type="radio"/>	<input checked="" type="radio"/>	<input checked="" type="radio"/>		<input checked="" type="radio"/>	<input checked="" type="radio"/>	<input checked="" type="radio"/>	<input type="radio"/>	<input type="radio"/>
		<input type="radio"/>	<input type="radio"/>	<input type="radio"/>	<input checked="" type="radio"/>	<input type="radio"/>	<input checked="" type="radio"/>	<input checked="" type="radio"/>		<input checked="" type="radio"/>	<input checked="" type="radio"/>	<input checked="" type="radio"/>	<input type="radio"/>	<input type="radio"/>
		<input type="radio"/>	<input type="radio"/>	<input type="radio"/>	<input checked="" type="radio"/>	<input type="radio"/>	<input checked="" type="radio"/>	<input checked="" type="radio"/>		<input checked="" type="radio"/>	<input checked="" type="radio"/>	<input checked="" type="radio"/>	<input type="radio"/>	<input type="radio"/>

	<input checked="" type="radio"/>	<input checked="" type="radio"/>	<input type="radio"/>	<input checked="" type="radio"/>	<input checked="" type="radio"/>	<input type="radio"/>		<input checked="" type="radio"/>	<input checked="" type="radio"/>	<input checked="" type="radio"/>	<input type="radio"/>	<input type="radio"/>		
	<input checked="" type="radio"/>	<input checked="" type="radio"/>	<input type="radio"/>	<input checked="" type="radio"/>	<input checked="" type="radio"/>	<input type="radio"/>		<input checked="" type="radio"/>	<input checked="" type="radio"/>	<input checked="" type="radio"/>	<input type="radio"/>	<input type="radio"/>		
	<input checked="" type="radio"/>	<input checked="" type="radio"/>	<input type="radio"/>	<input checked="" type="radio"/>	<input checked="" type="radio"/>	<input type="radio"/>		<input checked="" type="radio"/>	<input checked="" type="radio"/>	<input checked="" type="radio"/>	<input type="radio"/>	<input type="radio"/>		
	<input checked="" type="radio"/>	<input checked="" type="radio"/>	<input type="radio"/>	<input checked="" type="radio"/>	<input checked="" type="radio"/>	<input type="radio"/>		<input checked="" type="radio"/>	<input checked="" type="radio"/>	<input checked="" type="radio"/>	<input type="radio"/>	<input type="radio"/>		
	<input checked="" type="radio"/>	<input checked="" type="radio"/>	<input type="radio"/>	<input checked="" type="radio"/>	<input checked="" type="radio"/>	<input type="radio"/>		<input checked="" type="radio"/>	<input checked="" type="radio"/>	<input checked="" type="radio"/>	<input type="radio"/>	<input type="radio"/>		
	<input checked="" type="radio"/>	<input checked="" type="radio"/>	<input type="radio"/>	<input checked="" type="radio"/>	<input checked="" type="radio"/>	<input type="radio"/>		<input checked="" type="radio"/>	<input checked="" type="radio"/>	<input checked="" type="radio"/>	<input type="radio"/>	<input type="radio"/>		
6	6	3-6	4-6	6	6	1-3	6	4-6	6	3-6	6	3-6	1-3	

Suitable for machine

X														
			X											
	X													
					X									X

X														
						X					X			
		X												
									X					

X														
											X			
	X					X								
										X				
													X	













X														
											X			
	X					X								
												X		
								X						
									X					
													X	

Appropriate

Extremely appropriate

## Sawing and oscillating

### Circular saw blades

Colour code	Material	Recommended speed range
	 	<b>3-6</b>
	 	<b>3-5</b>
	 	<b>1-6</b>
	 <b>Fe</b>	<b>2-4</b>
	 <b>Al</b>	<b>3-6</b>

#### Special saw blade

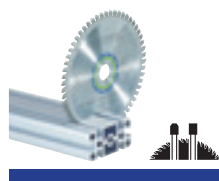

	Diameter	Cutting width	Hole Ø	No. of teeth	Chip angle	Tooth shape	RRP in £*	Order no.
<b>160x2,2x20 TF52</b>	160 mm	2,2 mm	20 mm	52	-5 °	TF	93,10 111,72	<b>496306</b>
<b>190x2,6 FF TF58</b>	190 mm	2,6 mm	FF **	58	-5 °	TF	117,90 141,48	<b>492051</b>
<b>190x2,8x30 TF68</b>	190 mm	2,8 mm	30 mm	68	-5 °	TF	118,00 141,60	<b>486299</b>
<b>210x2,4x30 TF72</b>	210 mm	2,4 mm	30 mm	72	-5 °	TF	139,30 167,16	<b>493201</b>
<b>216x2,3x30 W60</b>	216 mm	2,3 mm	30 mm	60	-5 °	TF	147,95 177,54	<b>491051</b>
<b>225x2,6x30 TF68</b>	225 mm	2,6 mm	30 mm	68	-5 °	TF	136,75 164,10	<b>488291</b>
<b>240x2,8x30 TF80</b>	240 mm	2,8 mm	30 mm	80	-5 °	TF	148,50 178,20	<b>438638</b>
<b>260x2,4x30 TF68</b>	260 mm	2,4 mm	30 mm	68	-5 °	TF	138,95 166,74	<b>494607</b>

#### Special saw blade

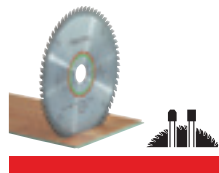

	Diameter	Cutting width	Hole Ø	No. of teeth	Chip angle	Tooth shape	RRP in £*	Order no.
<b>160x2,2x20 TF48</b>	160 mm	2,2 mm	20 mm	48	4 °	TF	93,10 111,72	<b>496308</b>
<b>190x2,6 FF TF54</b>	190 mm	2,6 mm	FF **	54	4 °	TF	117,90 141,48	<b>492052</b>
<b>190x2,6x30 TF54</b>	190 mm	2,6 mm	30 mm	54	4 °	TF	118,00 141,60	<b>489458</b>
<b>210x2,4x30 TF60</b>	210 mm	2,4 mm	30 mm	60	4 °	TF	139,30 167,16	<b>493200</b>
<b>225x2,6x30 TF64</b>	225 mm	2,6 mm	30 mm	64	4 °	TF	136,75 164,10	<b>489459</b>
<b>260x2,5x30 WZ/FA64</b>	260 mm	2,5 mm	30 mm	64	-5 °	WZ/FA	138,95 166,74	<b>494606</b>

#### Flat tooth saw blade

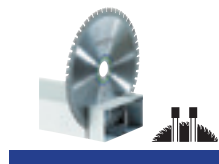

	Diameter	Cutting width	Hole Ø	No. of teeth	Chip angle	Tooth shape	RRP in £*	Order no.
<b>210x2,2x30 F36</b>	210 mm	2,2 mm	30 mm	36	1 °	F	97,25 116,70	<b>493351</b>
<b>240x2,6x30 F48</b>	240 mm	2,6 mm	30 mm	48	1 °	F	106,00 127,20	<b>487271</b>
<b>350x2,9x30 TF60</b>	350 mm	2,9 mm	30 mm	60	0 °	TF	203,70 244,44	<b>769668</b>

#### Special saw blade

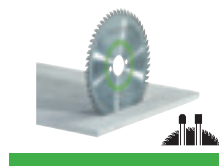

	Diameter	Cutting width	Hole Ø	No. of teeth	Chip angle	Tooth shape	RRP in £*	Order no.
<b>170x2,0x30 TF56</b>	170 mm	2,0 mm	30 mm	56	-4 °	TF	130,50 156,60	<b>435450</b>

#### Recommended speed range

\*\*FF = FastFix interface

\* Recommended retail price of manufacturer. Dealer prices may vary.  
Excl. VAT. Incl. VAT.

# Sawing and oscillating

## Circular saw blades

01

Coated panels, laminate panels
Veneered panels, parquet
Hard plastic, hard PVC
Hard, abrasive building panels, cement-bonded chipboard
Aluminium panels 8-25 mm, aluminium profiles
MDF and plasterboard, soft cement panels
Plywood, multiplex/multilayered wood
Acrylic glass
Fibre-reinforced plastics
Phenolic-resin-bonded fibres and fabrics
Steel cable ducts, multilayered board, false floors
MDF – Medium-density fibreboard
Melamine resin boards
Aluminium composite panels
Non-ferrous metals, copper, brass
Dry plaster material

### Processed material

	<input type="radio"/>	<input type="radio"/>	<input checked="" type="radio"/>			<input type="radio"/>	<input type="radio"/>	<input checked="" type="radio"/>	<input type="radio"/>	<input type="radio"/>
	<input type="radio"/>	<input type="radio"/>	<input checked="" type="radio"/>			<input type="radio"/>	<input type="radio"/>	<input checked="" type="radio"/>	<input type="radio"/>	<input type="radio"/>
	<input type="radio"/>	<input type="radio"/>	<input checked="" type="radio"/>			<input type="radio"/>	<input type="radio"/>	<input checked="" type="radio"/>	<input type="radio"/>	<input type="radio"/>
	<input type="radio"/>	<input type="radio"/>	<input checked="" type="radio"/>			<input type="radio"/>	<input type="radio"/>	<input checked="" type="radio"/>	<input type="radio"/>	<input type="radio"/>
	<input type="radio"/>	<input type="radio"/>	<input checked="" type="radio"/>			<input type="radio"/>	<input type="radio"/>	<input checked="" type="radio"/>	<input type="radio"/>	<input type="radio"/>
	<input type="radio"/>	<input type="radio"/>	<input checked="" type="radio"/>			<input type="radio"/>	<input type="radio"/>	<input checked="" type="radio"/>	<input type="radio"/>	<input type="radio"/>
	<input type="radio"/>	<input type="radio"/>	<input checked="" type="radio"/>			<input type="radio"/>	<input type="radio"/>	<input checked="" type="radio"/>	<input type="radio"/>	<input type="radio"/>
	<input type="radio"/>	<input type="radio"/>	<input checked="" type="radio"/>			<input type="radio"/>	<input type="radio"/>	<input checked="" type="radio"/>	<input type="radio"/>	<input type="radio"/>

	<input checked="" type="radio"/>	<input type="radio"/>	<input type="radio"/>		<input type="radio"/>	<input type="radio"/>	<input type="radio"/>	<input type="radio"/>	<input checked="" type="radio"/>	
	<input checked="" type="radio"/>	<input type="radio"/>	<input type="radio"/>		<input type="radio"/>	<input type="radio"/>	<input type="radio"/>	<input checked="" type="radio"/>	<input type="radio"/>	
	<input checked="" type="radio"/>	<input type="radio"/>	<input type="radio"/>		<input type="radio"/>	<input type="radio"/>	<input type="radio"/>	<input checked="" type="radio"/>	<input type="radio"/>	
	<input checked="" type="radio"/>	<input type="radio"/>	<input type="radio"/>		<input type="radio"/>	<input type="radio"/>	<input type="radio"/>	<input checked="" type="radio"/>	<input type="radio"/>	
	<input checked="" type="radio"/>	<input type="radio"/>	<input type="radio"/>		<input type="radio"/>	<input type="radio"/>	<input type="radio"/>	<input checked="" type="radio"/>	<input type="radio"/>	

						<input type="radio"/>	<input type="radio"/>	<input checked="" type="radio"/>		
						<input type="radio"/>	<input type="radio"/>	<input checked="" type="radio"/>		
								<input checked="" type="radio"/>		

			<input checked="" type="radio"/>		<input type="radio"/>				<input checked="" type="radio"/>	
6	6	4-6	1-3	4-6	1-3	6	4-6	4-6	3-6	2-3
6								4-6	4-6	3-6
										1-3

### Suitable for machine

X										
								X		
		X								
	X								X	
						X				
										X

X										
								X		
		X								
	X									
							X			
									X	

	X									
						X				
										X

							X			
--	--	--	--	--	--	--	---	--	--	--

Extremely appropriate  Appropriate

## Sawing and oscillating

### System accessories



#### Accessories for oscillator VECTURO OS 400

Denomination	Explanation	RRP in £*	Order no.
<b>1 Depth stop set OS-TA Set</b>	for OS 400, enables plunge cuts with a defined depth, adapter for mounting positioning aid and depth stop without tools, max. plunge depth, depth stop 56 mm, max. plunge depth, sliding shoe 20 mm, notch scale on depth adjuster 1,5 mm, weight 0,1 kg, in self-service display pack	39,65 47,58	<b>500160</b>
<b>2 Positioning aid set OS-AH Set</b>	for OS 400, enables precision positioning and sawing along a scribe mark, adapter for mounting positioning aid and depth stop without tools, max. plunge depth with position guide 60 mm, weight 0,3 kg, in self-service display pack	80,15 96,18	<b>500161</b>
<b>3 Positioning aid/depth stop set OS-TA/AH Set</b>	for OS 400, enables precision positioning and sawing along a scribe mark as well as plunge cuts to a defined depth, positioning aid, depth stop, adapter for mounting positioning aid and depth stop without tools, max. plunge depth, depth stop 56 mm, max. plunge depth, sliding shoe 20 mm, max. plunge depth with position guide 60 mm, notch scale on depth adjuster 1,5 mm, weight 0,47 kg, in self-service display pack	96,30 115,56	<b>500251</b>





Designation	Length (mm)	Width (mm)	Model	VE - Product No.	Solid wood	Wood containing nails	Raw/Coated chipboard	Plastic materials	Window putty	Adhesive	Silicone	FE-AL
<b>Saw blade, wood</b>												
Two rows of original Japan teeth for high-precision cuts and clean cutting edges. Note: Plunge-cuts not possible.		50	35	HSB 50/35/J	1x 500128 5x 500142 25x 500152	<input checked="" type="checkbox"/>	<input checked="" type="checkbox"/>	<input type="checkbox"/>	<input type="checkbox"/>	<input type="checkbox"/>	<input type="checkbox"/>	<input type="checkbox"/>
		50	45	HSB 50/45/J	1x 500132 5x 500146 25x 500156	<input checked="" type="checkbox"/>	<input checked="" type="checkbox"/>	<input type="checkbox"/>	<input type="checkbox"/>	<input type="checkbox"/>	<input type="checkbox"/>	<input type="checkbox"/>
		50	55	HSB 50/55/J	1x 500134 5x 500148 25x 500158	<input checked="" type="checkbox"/>	<input checked="" type="checkbox"/>	<input type="checkbox"/>	<input type="checkbox"/>	<input type="checkbox"/>	<input type="checkbox"/>	<input type="checkbox"/>
		50	65	HSB 50/65/J	1x 500131 5x 500145 25x 500155	<input checked="" type="checkbox"/>	<input checked="" type="checkbox"/>	<input type="checkbox"/>	<input type="checkbox"/>	<input type="checkbox"/>	<input type="checkbox"/>	<input type="checkbox"/>
<b>Saw blade, wood (HCS) – ideal in combination with the depth stop.</b>												
For long, straight cuts and cutting out sections of laid parquet or laminate flooring.		-	-	HSB 100/HCS	1x 500139	<input checked="" type="checkbox"/>	<input checked="" type="checkbox"/>	<input type="checkbox"/>	<input type="checkbox"/>	<input type="checkbox"/>	<input type="checkbox"/>	<input type="checkbox"/>
<b>Universal bi-metal saw blade for plunge-cuts</b>												
Accessories for interior fitting. For hardwood, softwood and all other types of wood. Also suitable for plastic and plasterboard. High cutting speed. Extremely durable and robust.		78	32	USB 78/32/Bi	1x 500129 5x 500143 25x 500153	<input type="checkbox"/>	<input checked="" type="checkbox"/>	<input checked="" type="checkbox"/>	<input checked="" type="checkbox"/>	<input type="checkbox"/>	<input type="checkbox"/>	<input type="checkbox"/>
		78	42	USB 78/42/Bi	1x 500133 5x 500147 25x 500157	<input type="checkbox"/>	<input checked="" type="checkbox"/>	<input checked="" type="checkbox"/>	<input checked="" type="checkbox"/>	<input type="checkbox"/>	<input type="checkbox"/>	<input type="checkbox"/>
		50	35	USB 50/35/Bi	1x 500130 5x 500144 25x 500154	<input type="checkbox"/>	<input checked="" type="checkbox"/>	<input checked="" type="checkbox"/>	<input checked="" type="checkbox"/>	<input type="checkbox"/>	<input type="checkbox"/>	<input type="checkbox"/>
		50	65	USB 50/65/Bi	1x 500135 5x 500149 25x 500159	<input type="checkbox"/>	<input checked="" type="checkbox"/>	<input checked="" type="checkbox"/>	<input checked="" type="checkbox"/>	<input type="checkbox"/>	<input type="checkbox"/>	<input type="checkbox"/>
<b>Bi-metal saw blade, metal</b>												
Ideal for machining aluminium and non-ferrous metals. With corrugated blade.		50	35	MSB 50/35/Bi	1x 500126 5x 500140 25x 500150	<input type="checkbox"/>	<input type="checkbox"/>	<input type="checkbox"/>	<input type="checkbox"/>	<input type="checkbox"/>	<input type="checkbox"/>	<input checked="" type="checkbox"/>
<b>HSS saw blade, offset (HCS). Segmented for working right into corners.</b>												
Countersunk clamping screw is perfectly flush.		-	-	SSB 100/HCS	1x 500136	<input type="checkbox"/>	<input checked="" type="checkbox"/>	<input checked="" type="checkbox"/>	<input checked="" type="checkbox"/>	<input checked="" type="checkbox"/>	<input checked="" type="checkbox"/>	<input checked="" type="checkbox"/>
<b>Special blade</b>												
For cutting out putty from insulating window panes, for example.		-	-	SSB 32	1x 500137	<input type="checkbox"/>	<input type="checkbox"/>	<input type="checkbox"/>	<input checked="" type="checkbox"/>	<input checked="" type="checkbox"/>	<input type="checkbox"/>	<input type="checkbox"/>
<b>Filler</b>												
For removing layers and coatings such as adhesive residue or silicone.		-	-	SSP 56,5/1	1x 500138	<input type="checkbox"/>	<input type="checkbox"/>	<input type="checkbox"/>	<input type="checkbox"/>	<input type="checkbox"/>	<input checked="" type="checkbox"/>	<input checked="" type="checkbox"/>

■ Wood blades

■ Universal blades

■ Metal blade

■ Special blades for window fitters and floor layers

● Appropriate



## Surface treatment

Overview of products and applications	50
---------------------------------------	----

## Sanding

<b>Gear-drive eccentric sander ROTEX</b> RO 90 DX, RO 125, RO 150	58
<b>Eccentric sanders</b> ETS 125, ETS EC 150, ETS 150, WTS 150	61
<b>Orbital sander</b> RS 100, RS 200, RS 300, RTS 400	66
<b>Delta sander</b> DTS 400	70
<b>Triangle sander DELTEX</b> DX 93	71
<b>Linear sander DUPLEX</b> LS 130	72
<b>Rotary sanders</b> RAS 115, RAS 180	73
<b>Belt sander</b> BS 75, BS 105, CMS-BS	75

## Sanding with compressed air

<b>Compressed air eccentric sander</b> LEX 2, LEX 3	78
<b>Compressed air RUTSCHER</b> LRS 93, LRS 400	82

## Polishing and oiling

<b>Rotary polishers</b> RAP 80, SHINEX RAP 150, POLLUX 180	85
<b>SURFIX oil dispenser</b> OS	88

## Brushing and texturing

<b>Brush machine RUSTOFIX</b> BMS 180	89
---------------------------------------	----

## Accessories and consumable materials

The Festool system	90
--------------------	----

# Surface treatment

## Overview of products and applications

Page 58 ————— 59 ————— 60

Whether you need to remove material quickly and efficiently or achieve a particularly fine sanding finish – your applications determine the requirements and Festool sanders provide all the answers. Simply select the right machine for your most frequently performed practical applications.

RO 90 DX

RO 125

RO 150



### Applications

#### Gear-drive eccentric sander ROTEX

#### Flat surfaces

Coarse sanding	<input type="radio"/>	<input checked="" type="radio"/>	<input checked="" type="radio"/>
Rough sanding	<input type="radio"/>	<input checked="" type="radio"/>	<input checked="" type="radio"/>
Fine sanding	<input type="radio"/>	<input checked="" type="radio"/>	<input checked="" type="radio"/>
Extra-fine sanding	<input type="radio"/>	<input type="radio"/>	<input type="radio"/>

#### Curved surfaces

Coarse sanding	<input type="radio"/>	<input checked="" type="radio"/>	<input checked="" type="radio"/>
Rough sanding	<input checked="" type="radio"/>	<input checked="" type="radio"/>	<input checked="" type="radio"/>
Fine sanding	<input checked="" type="radio"/>	<input checked="" type="radio"/>	<input checked="" type="radio"/>
Extra-fine sanding	<input type="radio"/>	<input type="radio"/>	<input type="radio"/>

#### Internal corners

Coarse sanding	<input checked="" type="radio"/>	<input type="radio"/>	<input type="radio"/>
Rough sanding	<input checked="" type="radio"/>	<input type="radio"/>	<input type="radio"/>
Fine sanding	<input checked="" type="radio"/>	<input type="radio"/>	<input type="radio"/>
Extra-fine sanding	<input type="radio"/>	<input type="radio"/>	<input type="radio"/>

#### Polishing

Small surfaces	<input checked="" type="radio"/>	<input checked="" type="radio"/>	<input type="radio"/>
Large surfaces	<input type="radio"/>	<input type="radio"/>	<input checked="" type="radio"/>

### Technical data

	400	500	720
Power consumption (W)	400	500	720
ROTEX rotary motion speed (rpm)	260-520	300-600	320-660
Eccentric motion speed (rpm)	3500-7000	3000-6000	3300-6800
Sanding stroke (mm)	3	3,6	5
Sanding pad Ø (mm)	90	125	150
Weight (kg)	1,5	1,9	2,3

61      62      62      63      63      64

ETS 125      ETS 150/3      ETS 150/5      ETS EC 150/3      ETS EC 150/5      WTS 150/7



Eccentric sander



Extremely appropriate    Appropriate

	200	310	310	400	400	400
	6000-14000	4000-10000	4000-10000	6000-10000	6000-10000	2600-6000
	2	3	5	3	5	7
	125	150	150	150	150	150
	1,1	1,8	1,8	1,2	1,2	1,9

# Surface treatment

## Overview of products and applications

Page 66 — 66 — 67 — 68 — 69

RS 100

RS 100 C

RS 200

RS 300

RTS 400



### Applications

#### Geared orbital sanders

#### Direct-drive RUTSCHER

#### Flat surfaces

Coarse sanding



Rough sanding



Fine sanding



Extra-fine sanding



#### Curved surfaces

Coarse sanding

Rough sanding

Fine sanding

Extra-fine sanding

#### Internal corners

Coarse sanding

Rough sanding

Fine sanding

Extra-fine sanding

#### Profiles

Coarse sanding

Rough sanding

Fine sanding

Extra-fine sanding

#### Technical data

	RS 100	RS 100 C	RS 200	RS 300	RTS 400
Power consumption (W)	620	620	330	280	200
Idle engine speed (rpm)	6000	6300	4000-10000	4000-10000	6000-14000
Sanding stroke (mm)	5	5	2,4	2,4	2
Sanding pad (mm)	115 x 225	115 x 225	115 x 225	93 x 175	80 x 130
Weight (kg)	3,3	3	2,5	2,3	1,1

70 ——— 71 ——— 72

**DTS 400**                      **DX 93**                      **LS 130**



**Delta and triangular sanders**

**Linear sander  
DUPLEX**

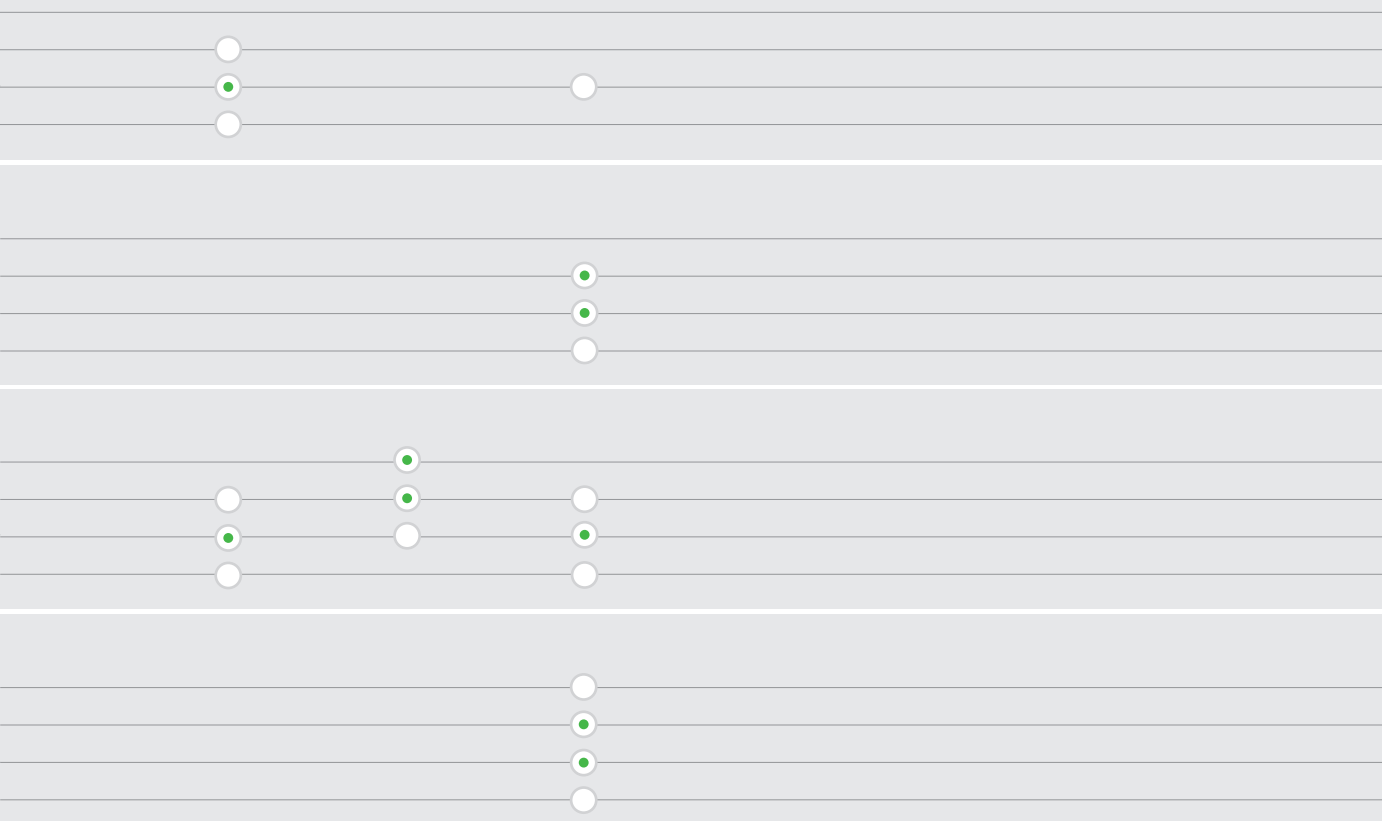

● Extremely appropriate    ○ Appropriate

	200	150	260
	6000-14000	5000-9500	4000-6000
	2	2,5	4
	100 x 150		133 x 80
	1,1	1,5	1,7

# Surface treatment

## Overview of products and applications

Page 73 ————— 74

RAS 115

RAS 180



### Applications

### Rotary sanders

#### Flat surfaces

- Coarse sanding
- Rough sanding
- Fine sanding
- Extra-fine sanding

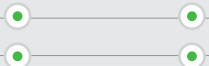

#### Curved surfaces

- Coarse sanding
- Rough sanding
- Fine sanding
- Extra-fine sanding

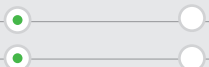

#### Internal corners

- Coarse sanding
- Rough sanding
- Fine sanding
- Extra-fine sanding

#### Profiles

- Coarse sanding
- Rough sanding
- Fine sanding
- Extra-fine sanding

#### Texturing surfaces

#### Technical data

Power consumption (W)	500	1500	
Idle engine speed (rpm)	1350-3800	800-4000	
Sanding pad Ø (mm)	115	180	
Belt length x belt width (mm)			
Sanding area (mm)			
Tool Ø (mm)			
Weight (kg)	2,3	4,2	



75 ——— 75 ——— 76 ——— 89

**BS 75**                      **BS 105**                      **CMS-BS**                      **BMS 180**

**Special sanders**  
for drywalling  
Page 321

02



**Belt sander**

**Compact Module System CMS**

**RUSTOFIX brush machine**

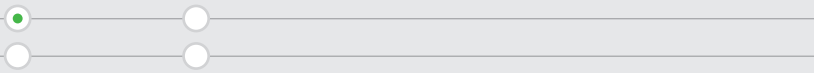

Extremely appropriate     Appropriate

	1010	1400	550	1500
			2800	800-4000
	533 x 75	620 x 105	820 x 120	
	135 x 75	160 x 105	185 x 115	
				150
	3,8	6,5		7,5

# Surface treatment

## Overview of products and applications

Page 78 — 79 — 79 — 80 — 80

LEX 3 77

LEX 3 125/3

LEX 3 125/5

LEX 3 150/3

LEX 3 150/5



### Applications

### LEX compressed air eccentric sander

#### Flat surfaces

- Coarse sanding
- Rough sanding
- Fine sanding
- Extra-fine sanding



#### Curved surfaces

- Coarse sanding
- Rough sanding
- Fine sanding
- Extra-fine sanding



#### Internal corners

- Coarse sanding
- Rough sanding
- Fine sanding
- Extra-fine sanding



#### Polishing

- Small surfaces
- Large surfaces

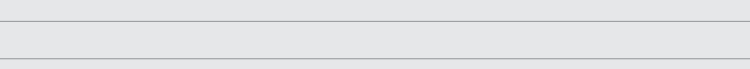

### Technical data

Operating pressure (flow pressure) (bar)	6	6	6	6	6
Power consumption (W)					
Idle engine speed (rpm)					
Eccentric motion speed (rpm)	10500	9500	9500	10000	10000
No. of strokes (rpm)	21000	19000	19000	20000	20000
Sanding stroke (mm)	2,5	3	5	3	5
Pad Ø (mm)	77	125	125	150	150
Sanding pad StickFix (mm)					
Air consumption at rated load (l/min)	270	290	290	290	290
Weight (kg)	0,7	0,9	0,95	1,0	1,0

# Surface treatment

## Overview of products and applications

80 ——— 81 ——— 82 ——— 83 ——— 85 ——— 86 ——— 87

LEX 3 150/7      LEX 2 185/7      LRS 93      LRS 400      RAP 80      SHINEX RAP 150      POLLUX 180



LEX compressed air eccentric sander

Compressed air orbital sander

Rotary polisher

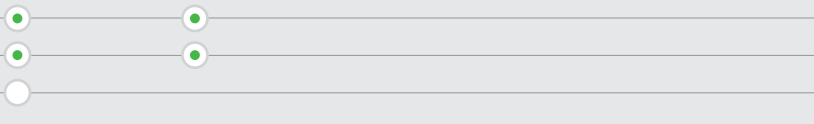
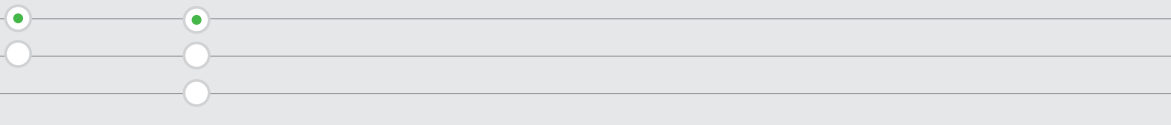

Extremely appropriate     Appropriate

	6	6	6	6			
					500	1200	1500
					750-2300	400-2100	800-2400
	10000	8000					
	20000	16000	14000	14000			
	7	7	4	4			
	150	185			80	150	180
			93 x 175	80 x 400			
	310	390	310	390			
	1,0	1,4	1,2	2,3	1,6	2,1	3,6

## Surface treatment

Geared eccentric sander ROTEX RO 90 DX



product  
design  
award

2011



# ROTEX RO 90 DX



### Round tool that also sands in corners.

- ▶ Four machines in one: High material removal capacity in coarse sanding mode with ROTEX rotary motion, extra-fine sanding pattern in intermediate sanding and fine sanding stages, cleaner corners with the delta sanding pad and shiny results when polishing
- ▶ Durable eccentric bearings, a double-sealed gear unit and a dustproof switch extend the service life of the machine
- ▶ ROTEX rotary motion for convenient polishing – the reduced speed keeps the temperature low and prevents the polish from clouding or spraying off
- ▶ FastFix sanding pad system, tool-less

#### Technical data

Power consumption (W)	400
ROTEX rotary motion speed (min <sup>-1</sup> )	260-520
Eccentric motion speed (min <sup>-1</sup> )	3500-7000
Sanding stroke (mm)	3
FastFix sanding pad Ø (mm)	90
Connection Ø d/e (mm)	27
weight (kg)	1,5



= with MMC electronics

#### Items Included

FastFix sanding pad, Ø 90 mm (soft-HT), StickFix sanding pad V93, Festool PROTECTOR, in a SYSTAINER SYS 2 T-LOC

	RRP in £*	Order no.
<b>RO 90 DX FEQ-Plus GB 240V</b>	381,00 457,20	<b>571821</b>
<b>RO 90 DX FEQ-Plus GB 110V</b>	381,00 457,20	<b>571822</b>

### Four tools in one.

One machine that can be used for coarse sanding, fine sanding, polishing and delta sanding. Low initial costs, maximum flexibility and a wide range of applications. More efficient and saves more time.

\* Recommended retail price of manufacturer. Dealer prices may vary.  
Excl. VAT.  
Incl. VAT.

#### System accessories from page 92



#### Abrasives from page 107

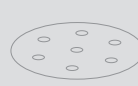

#### Watch the product video





# ROTEX RO 125



### Handy all-rounder.

- ▶ A powerful motor and combination of eccentric and orbital motion removes material three times faster than conventional eccentric sanders
- ▶ Three machines in one: aggressive material removal when coarse sanding, extra-fine sanding pattern when fine sanding and perfect gleaming surfaces when polishing
- ▶ Healthy, efficient dust extraction with the Jetstream principle
- ▶ FastFix sanding pad system, tool-less

#### Technical data

Power consumption (W)	500
ROTEX rotary motion speed (min <sup>-1</sup> )	300-600
Eccentric motion speed (min <sup>-1</sup> )	3000-6000
Sanding stroke (mm)	3,6
FastFix sanding pad Ø (mm)	125
Connection Ø d/e (mm)	27
weight (kg)	1,9



= with MMC electronics

Items Included	RRP in £*	Order no.
FastFix sanding pad Ø 125 mm (soft-HT), Festool PROTECTOR, in a SYSTAINER SYS 2 T-LOC		
<b>RO 125 FEQ Plus GB 240V</b>	392,00 470,40	<b>571784</b>

\* Recommended retail price of manufacturer. Dealer prices may vary.  
Excl. VAT.  
Incl. VAT.

System accessories  
from page 93



Abrasives  
from page 107



### Extremely durable.

With robust eccentric bearings, a double-sealed housing and dustproof switches, the ROTEX can even withstand long periods of continuous use.

## Surface treatment

Geared eccentric sander ROTEX RO 150



product  
design  
award

2006

# ROTEX RO 150



### Short tooling times thanks to FastFix pad change.

Simple, quick and safe. You don't need any other tools for changes apart from your hands. Simply remove the pad, replace and carry on working ...

### The original 3-in-1 principle with powerful machine concept.

- ▶ Three machines in one: aggressive material removal when coarse sanding, extra-fine sanding pattern when fine sanding and perfect gleaming surfaces when polishing
- ▶ ROTEX rotary motion for convenient polishing – reduced speed keeps the temperature low, even on the powerful RO 150, prevents the polish from smearing or spraying off
- ▶ FastFix sanding pad system, tool-less
- ▶ MULTI-JETSTREAM principle for efficient dust extraction at maximum sanding capacity

#### Technical data

Power consumption (W)	720
ROTEX rotary motion speed (min <sup>-1</sup> )	320-660
Eccentric motion speed (min <sup>-1</sup> )	3300-6800
Sanding stroke (mm)	5
FastFix sanding pad Ø (mm)	150
Connection Ø d/e (mm)	27
weight (kg)	2,3



= with MMC electronics

Items Included	RRP in £*	Order no.
FastFix sanding pad Ø 150 mm (soft HT), StickFix sanding disc Brilliant 2, Festool PROTECTOR, in a SYSTAINER SYS 3 T-LOC		
<b>RO 150 FEQ-Plus GB 240V</b>	468,00 561,60	<b>571808</b>
<b>RO 150 FEQ-Plus GB 110V</b>	468,00 561,60	<b>571809</b>

\* Recommended retail price of manufacturer. Dealer prices may vary.  
Excl. VAT.  
Incl. VAT.

#### System accessories from page 94



#### Abrasives from page 107



ETS 125



**The compact one-handed sander.**

- ▶ One-handed operation, ideal for overhead work
- ▶ Small, lightweight and extremely handy for non-tiring work
- ▶ Extremely smooth operation, perfect ergonomics, stepless speed adjustment and reliable sanding pad brake
- ▶ 2 mm sanding stroke perfect for superior surface quality during finishing or preliminary sanding work

Technical data	ETS 125 EQ	ETS 125 Q
Power consumption (W)	200	
Power consumption (W)		200
Eccentric motion speed (min <sup>-1</sup> )	6000-14000	
Eccentric motion speed (min <sup>-1</sup> )		14000
Sanding stroke (mm)	2	2
No. of strokes (min <sup>-1</sup> )		28000
Interchangeable sanding pad Ø (mm)	125	125
Connection Ø d/e (mm)	27	27
weight (kg)	1,1	1,1



■ = with electronics

Items Included	RRP in £*	Order no.
StickFix sanding pad Ø 125 mm (soft-HT), StickFix sanding disc Brilliant 2, filter cartridge		
<b>ETS 125 Q GB 240V</b> in a carton	193,00 231,60	<b>571671</b>
<b>ETS 125 EQ GB 240V</b> in a carton	226,00 271,20	<b>571619</b>
<b>ETS 125 EQ-Plus GB 240V</b> in a SYSTAINER SYS 2 T-LOC	254,00 304,80	<b>571818</b>

\* Recommended retail price of manufacturer. Dealer prices may vary.  
Excl. VAT.  
Incl. VAT.

System accessories  
from page 95



Abrasives  
from page 107



**Better handling, less strenuous work.**

The ergonomic design of the compact sander is ideal for one-handed operation – for right and left-handers. The machine is perfectly balanced so that sanding pads run smoothly, allowing you to work effortlessly for longer.

## Surface treatment

### Eccentric sander ETS 150



## ETS 150



### Perfect finishing sander.

- ▶ The ETS 150 is available in two versions: With a 3 mm sanding stroke for an immaculate surface finish or with a 5 mm sanding stroke for intermediate sanding of clear coats or lacquer
- ▶ Dual bearing for a long service life
- ▶ Weighs only 1.8 kg for particularly effortless work
- ▶ Sanding pad brake for safe, faultless work with no reworking costs

Technical data	ETS 150/3	ETS 150/5
Power consumption [W]	310	310
Eccentric motion speed [min <sup>-1</sup> ]	4000-10000	4000-10000
Sanding stroke [mm]	3	5
Interchangeable sanding pad Ø [mm]	150	150
Connection Ø d/e [mm]	27	27
weight [kg]	1,8	1,8



= with MMC electronics

Items Included	RRP in £*	Order no.
filter cartridge, operation tool, in a SYSTAINER SYS 3 T-LOC		
<b>ETS 150/3 EQ-Plus GB 240V</b>	303,00	<b>571901</b>
StickFix sanding pad Ø 150 mm FUSION-TEC (extra-soft)	363,60	
<b>ETS 150/3 EQ-Plus GB 110V</b>	303,00	<b>571907</b>
StickFix sanding pad Ø 150 mm FUSION-TEC (extra-soft)	363,60	
<b>ETS 150/5 EQ-Plus GB 240V</b>	303,00	<b>571917</b>
StickFix sanding pad Ø 150 mm FUSION-TEC (soft HT)	363,60	
<b>ETS 150/5 EQ-Plus GB 110V</b>	303,00	<b>571920</b>
StickFix sanding pad Ø 150 mm FUSION-TEC (soft HT)	363,60	

### Perfect surface quality.

The ETS 150/3 is a favourite for fine sanding and extra-fine sanding. A lightweight in its class, it produces an excellent surface finish with a 3 mm sanding stroke. The ETS 150/5, with a 5 mm stroke, is a favourite for light sanding or sanding between paint coats. Its manoeuvrability is an example of outstanding ergonomics.

\* Recommended retail price of manufacturer. Dealer prices may vary.  
Excl. VAT.  
Incl. VAT.

#### System accessories from page 96



#### Abrasives from page 107

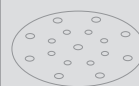



## Surface treatment

### Random orbit sander ETS EC 150



Brushless EC-TEC motor for a long service life and a high level of efficiency

02

# ETS EC 150

### The perfect finishing sander in the compact class.

- ▶ Longlife thanks to EC technology and carbide-tipped sanding pad brake
- ▶ Compact design and weighing only 1.2 kg for optimal ergonomic working conditions
- ▶ Stepless speed preselection, constant speed even under load
- ▶ Maximum safety while working thanks to vibration and extraction detection

Technical data	ETS EC 150/3	ETS EC 150/5
Power consumption (W)	400	400
Eccentric motion speed (min <sup>-1</sup> )	6000-10000	6000-10000
Sanding stroke (mm)	3	5
Interchangeable sanding pad Ø (mm)	150	150
Connection Ø d/e (mm)	27	27
weight (kg)	1,2	1,2



☐ = with MMC electronics

Items Included	RRP in £*	Order no.
operation tool		
<b>ETS EC 150/3 EQ GB 240V</b>	383,00	<b>571877</b>
StickFix sanding pad Ø 150 mm FUSION-TEC (extra-soft), in a carton	459,60	
<b>ETS EC 150/3 EQ-Plus GB 240V</b>	408,00	<b>571876</b>
StickFix sanding pad Ø 150 mm FUSION-TEC (extra-soft), in a SYSTAINER SYS 2 T-LOC	489,60	
<b>ETS EC 150/3 EQ-Plus-GQ GB 240V</b>	509,00	<b>571947</b>
StickFix sanding pad Ø 150 mm FUSION-TEC (extra-soft), suction hose D27/22x3.5 m AS-GQ, in a SYSTAINER SYS 2 T-LOC	610,80	
<b>ETS EC 150/5 EQ GB 240V</b>	383,00	<b>571889</b>
StickFix sanding pad Ø 150 mm FUSION-TEC (soft HT), in a carton	459,60	
<b>ETS EC 150/5 EQ-Plus GB 240V</b>	408,00	<b>571888</b>
StickFix sanding pad Ø 150 mm FUSION-TEC (soft HT), in a SYSTAINER SYS 2 T-LOC	489,60	
<b>ETS EC 150/5 EQ-Plus-GQ GB 240V</b>	509,00	<b>571958</b>
StickFix sanding pad Ø 150 mm FUSION-TEC (soft HT), suction hose D27/22x3.5 m AS-GQ, in a SYSTAINER SYS 2 T-LOC	610,80	

\* Recommended retail price of manufacturer. Dealer prices may vary.  
Excl. VAT.  
Incl. VAT.

#### System accessories from page 96



#### Abrasives from page 107



#### Watch the product video



### Sanding has many sides. We've thought of them all.

Overhead, at vertical areas or narrow edges – the new ETS EC 150 takes up position in all circumstances: Perfection with handling and sanding result. Thanks to the high-performance and brushless EC-TEC motor, the compact ETS EC 150 is ideal for one-handed and effortless work with simultaneously high demands for smooth running and surface quality.

## Surface treatment

Eccentric sander WTS 150

# WTS 150



### Outstanding handling.

Powerful in action and tough wearing. The sturdy construction of the WTS 150 is designed with high-quality components for maximum durability. The WTS 150 has a whole lot more in store to make your work easier: ergonomic design; VibrationsStop; dust extraction system.

### Powerful eccentric sander.

- ▶ Powerful with a 7 mm sanding stroke, pleasant to use – for effortless sanding of large areas
- ▶ Extremely powerful for efficient work
- ▶ Sanding pad brake for safe, faultless work with no reworking costs
- ▶ Extremely smooth running and infinitely variable speed adjustment

#### Technical data

Power consumption (W)	400
Eccentric motion speed (min <sup>-1</sup> )	2600-6000
Sanding stroke (mm)	7
Interchangeable sanding pad Ø (mm)	150
Connection Ø d/e (mm)	27
weight (kg)	1,9



= with MMC electronics

Items Included	RRP in £*	Order no.
StickFix sanding pad Ø 150 mm (soft HT), StickFix sanding disc Brilliant 2, additional side-mounted hand grip, operation tool, in a SYSTAINER SYS 2 T-LOC		
<b>WTS 150/7 E-Plus GB 240V</b>	300,00 360,00	<b>571831</b>

\* Recommended retail price of manufacturer. Dealer prices may vary.  
Excl. VAT.  
Incl. VAT.

#### System accessories from page 96



#### Abrasives from page 107

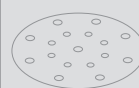



**What is the best way to obtain a perfect surface?  
With a system.**

Rapid material removal and fine sanding pattern as a basis for the perfect finish or preparing high gloss surface. In no other area is the system concept as evident as the development of our sanding tools. Robust, ergonomic tools that were designed to be used effortlessly for long periods. With individually adapted pads and abrasive sheets for transferring force perfectly and abrasives developed with the same care as the machines themselves.

A system concept that focusses on perfect tools and perfect results as well as the people we design our tools for.

### The sanding pad system.

Sanding pads suitable for every type of application are available in different degrees of hardness ranging from extra-soft to hard. Easy to change with Jetstream principle that reduces surface heat and ensures efficient dust extraction.



+



+

### Abrasive system.

Adapted perfectly to every tool, pad and dust extractor. Individually designed for every application, from coarse to fine sanding. Festool abrasives have an extended useful life and are fast and easy to change due to the StickFix adhesive cushion strips.

### The extraction and workspace system.

A well-planned workplace saves time and journeys. A good dust extraction system keeps the air free of dust and ensures consistent quality results while preventing the lungs from inhaling sanding dust.



## Surface treatment

### RUTSCHER RS 100



product  
design  
award

2001



# RUTSCHER RS 100



### High material removal rate.

Festool gear-drive sanders with reduction gearing are always designed for heavy-duty material removal and are therefore suitable for sanding old, thick and stubborn coatings over large surfaces.

### Professional with integral extractor.

- ▶ Reduction gearing for consistently efficient material removal – perfect for sanding off stubborn coatings
- ▶ Vibration stop for smooth operation and safe working conditions
- ▶ Clean working environment – efficient dust extraction for a clear view of the working area and a workplace free from dust
- ▶ Well-balanced centre of gravity for outstanding results and non-tiring work

Technical data	RS 100 Q	RS 100 CQ
Power consumption (W)	620	620
Idle engine speed (min <sup>-1</sup> )	6000	6300
Max. speed (min <sup>-1</sup> )		10000
Sanding stroke (mm)	5	5
No. of strokes (min <sup>-1</sup> )		12600
Interchangeable sanding pad (mm)	115 x 225	115 x 225
Connection Ø d/e (mm)	27	27
weight (kg)	3,3	3,0



Items Included	RRP in £*	Order no.
in a SYSTAINER SYS 2 T-LOC		
<b>RS 100 Q-Plus GB 240V</b>	468,00	<b>567884</b>
StickFix sanding pad 115 x 225 mm, filter cartridge	561,60	
<b>RS 100 CQ-Plus GB 240V</b>	430,00	<b>567885</b>
StickFix sanding pad 115 x 221 mm	516,00	

\* Recommended retail price of manufacturer. Dealer prices may vary.  
Excl. VAT.  
Incl. VAT.

#### System accessories from page 97

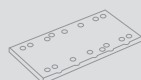

#### Abrasives from page 107

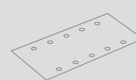



# RUTSCHER RS 200



## Master of large surfaces.

- ▶ Large sanding pad and high speed for an excellent surface quality in intermediate sanding and final sanding of clear coats and lacquer without requiring rework
- ▶ Large sanding base for economical sanding over large areas
- ▶ Ability to sand up to the edge on three sides
- ▶ The enclosed dustproof bearing and extremely tear-resistant MPE sanding pad ensure a long service life and maximum economic efficiency

### Technical data

Power consumption (W)	330
Idle engine speed (min <sup>-1</sup> )	4000-10000
No. of strokes (min <sup>-1</sup> )	8000-20000
Sanding stroke (mm)	2,4
Interchangeable sanding pad (mm)	115 x 225
Connection Ø d/e (mm)	27
weight (kg)	2,5



= with electronics

## Perfect sanding finish.

The RS 200 produces outstanding quality over large surfaces: it has a 2.4 mm sanding stroke and direct drive; its large sanding pad ensures economical intermediate varnish and final sanding, eg light sanding of doors or large surface areas on furniture. The ability to sand right into corners and edges minimises reworking.

Items Included	RRP in £*	Order no.
StickFix sanding pad 115 x 225 mm, filter cartridge, in a SYSTAINER SYS 2 T-LOC		
<b>RS 200 EQ-Plus GB 240V</b>	386,00 463,20	<b>567881</b>

\* Recommended retail price of manufacturer. Dealer prices may vary.  
Excl. VAT.  
Incl. VAT.

### System accessories from page 97

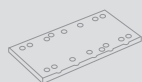

### Abrasives from page 107

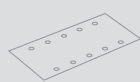

## Surface treatment

### RUTSCHER RS 300



product  
design  
award

2001



# RUTSCHER RS 300



### A multi-talent.

- ▶ Different interchangeable sanding pads for an extremely wide range of applications
- ▶ Optimal ratio between size, weight and sanding pad – perfect for surface areas, corners, edges, ceilings
- ▶ Ergonomic shape ensures non-tiring work, even on vertical surfaces and work overhead
- ▶ A sturdy bearing, secure oscillators and an extremely tear-resistant MPE sanding pad to ensure a long service life

#### Technical data

Power consumption (W)	280
Idle engine speed (min <sup>-1</sup> )	4000-10000
No. of strokes (min <sup>-1</sup> )	8000-20000
Sanding stroke (mm)	2,4
Interchangeable sanding pad (mm)	93 x 175
Connection Ø d/e (mm)	27
weight (kg)	2,3



= with electronics

Items Included	RRP in £*	Order no.
StickFix sanding pad 93 x 175 mm, filter cartridge, in a SYSTAINER SYS 2 T-LOC		
<b>RS 300 EQ-Plus GB 240V</b>	311,00 373,20	<b>567768</b>
<b>RS 300 EQ-Set GB 240V</b> V-shaped sanding pad	330,00 396,00	<b>567883</b>

### When things get a little tight.

Universal application – the RS 300 has the right sanding pad for almost every task.

\* Recommended retail price of manufacturer. Dealer prices may vary.  
Excl. VAT.  
Incl. VAT.

#### System accessories from page 97

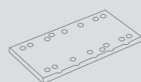

#### Abrasives from page 107

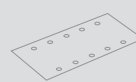



# RUTSCHER RTS 400

## Compact one-handed sander.

- ▶ An even sanding pattern and the ability to sand close to edges on three sides keeps reworking to a minimum
- ▶ The enclosed dustproof bearing and extremely tear-resistant MPE sanding pad ensure a long service life and maximum economic efficiency
- ▶ Compact, ergonomic and easy to operate for both right and left-handers
- ▶ Effective integral turbo dust extractor



Technical data	RTS 400 EQ	RTS 400 Q
Power consumption (W)	200	
Power consumption (W)		200
Idle engine speed (min <sup>-1</sup> )	6000-14000	14000
No. of strokes (min <sup>-1</sup> )	12000-28000	28000
Sanding stroke (mm)	2	2
Interchangeable sanding pad (mm)	80 x 130	80 x 130
Connection Ø d/e (mm)	27	27
weight (kg)	1,1	1,1



☐ = with electronics

Items Included	RRP in £*	Order no.
StickFix sanding pad 80 x 130 mm, StickFix abrasive, filter cartridge		
<b>RTS 400 EQ GB 240V</b> in a carton	226,00 271,20	<b>567680</b>
<b>RTS 400 EQ-Plus GB 240V</b> in a SYSTAINER SYS 1 T-LOC	248,00 297,60	<b>567866</b>
<b>RTS 400 Q GB 240V</b> in a carton	193,00 231,60	<b>567684</b>
<b>RTS 400 Q-Plus GB 240V</b> in a SYSTAINER SYS 1 T-LOC	217,00 260,40	<b>567771</b>

## Clean working environment.

Efficient dust extraction for a clear view of the working area and a workplace free from dust.

\* Recommended retail price of manufacturer. Dealer prices may vary.  
Excl. VAT.  
Incl. VAT.

System accessories  
from page 98

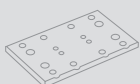

Abrasives  
from page 107

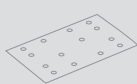

## Surface treatment

Delta sander DTS 400

# DTS 400



### Sanding in corners and along edges.

Perfect preparation of windows and doors – the DTS 400 with iron-shaped pad can be guided accurately along narrow edges and into corners.



### Compact corner sander.

- ▶ For fine sanding into corners, along edges and other awkward spots with the delta sanding pad – the edge protector protects the workpiece
- ▶ Flexible – option of working with an integral dust bag or a mobile dust extractor
- ▶ Perfect when working for longer periods – ergonomic shape, low weight, easy to guide

#### Technical data

Power consumption (W)	200
Idle engine speed (min <sup>-1</sup> )	6000-14000
Sanding stroke (mm)	2
Interchangeable sanding pad (mm)	100 x 150
Connection Ø d/e (mm)	27
weight (kg)	1,1



= with electronics

Items Included	RRP in £*	Order no.
StickFix sanding pad 100 x 150 mm, StickFix abrasive sheets DS400, filter cartridge, in a SYSTAINER SYS 2 T-LOC		
<b>DTS 400 EQ-Plus GB 240V</b>	248,00 297,60	<b>567872</b>

\* Recommended retail price of manufacturer. Dealer prices may vary.  
Excl. VAT.  
Incl. VAT.

#### System accessories from page 98



#### Abrasives from page 107







product design award  
1995



# DELTEX DX 93



## Rotatable sanding pad.

High-strength sanding pad made from MPE: rotate the pad for maximum utilisation with the StickFix quick-change system.

### Powerful corner sander.

- ▶ Durable – hard-wearing bevel gears with above-average rate of material removal and bearings in a dustproof enclosure
- ▶ Simply attach a slat sanding pad to sand into small spaces
- ▶ Saves time and money – the triangular sanding pad can be rotated so that all three sides are used evenly

#### Technical data

Power consumption (W)	150
Idle engine speed (min <sup>-1</sup> )	5000-9500
Sanding stroke (mm)	2,5
Connection Ø d/e (mm)	27
weight (kg)	1,5



= with electronics

Items Included	RRP in £*	Order no.
StickFix sanding pad 93 V (soft), StickFix slat sanding pad, plate, in a SYSTAINER SYS 2 T-LOC		
<b>DX 93 E-Plus GB 240V</b>	239,00 286,80	<b>567203</b>

\* Recommended retail price of manufacturer. Dealer prices may vary.  
Excl. VAT.  
Incl. VAT.

#### System accessories from page 98



#### Abrasives from page 107



## Surface treatment

Linear sander DUPLEX LS 130



# DUPLEX LS 130



### Profile sander.

- ▶ Linear motion provides an efficient alternative to manual work in rebates and profiles for non-tiring work
- ▶ Always the right sanding pad – 11 standard pads and a DIY construction kit for manufacturing sanding pads of any shape
- ▶ Simple, quick and tool-less sanding pad changes
- ▶ Wear-resistant design for a long service life

#### Technical data

Power consumption (W)	260
Idle engine speed (min <sup>-1</sup> )	4000-6000
No. of strokes (min <sup>-1</sup> )	8000-12000
Sanding stroke (mm)	4
Interchangeable sanding pad (mm)	133 x 80
Connection Ø d/e (mm)	27
weight (kg)	1,7



= with electronics

Items Included	RRP in £*	Order no.
StickFix profile sanding pad standard, profile sanding pad 90°, in a SYSTAINER SYS 1 T-LOC		
<b>LS 130 EQ-Plus GB 240V</b>	349,00 418,80	<b>567853</b>

### Curves and profiles.

The DUPLEX is ideal for sanding curves and profiles, thanks to its linear motion, the DIY kit and a large selection of sanding pads.

\* Recommended retail price of manufacturer. Dealer prices may vary.  
Excl. VAT.  
Incl. VAT.

#### System accessories from page 99

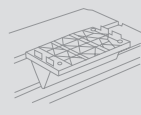

#### Abrasives from page 107

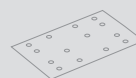



RAS 115

### Heavy-duty sander.

- ▶ No more rework – the speed of the machine is ideal for removing layers of paint
- ▶ With ergonomic design and narrow housing diameter of 58 mm, ideal for non-tiring work on smaller surfaces and along edges
- ▶ Work without interruptions – FastFix system for quick pad changes without using tools

#### Technical data

Power consumption (W)	500
Idle engine speed (min <sup>-1</sup> )	1350-3800
Interchangeable sanding pad Ø (mm)	115
Spindle thread	M14
Connection Ø d/e (mm)	27
weight (kg)	2,3



= with MMC electronics

Items Included	RRP in £*	Order no.
StickFix sanding pad Ø 115 mm, sanding pad 2F Ø 115 mm, StickFix abrasive discs, extraction hood, protective cover, additional side-mounted hand grip, operation tool, in a SYSTAINER SYS 2 T-LOC		
<b>RAS 115 E-Set GB 240V</b>	328,00 393,60	<b>570793</b>

\* Recommended retail price of manufacturer. Dealer prices may vary.  
Excl. VAT.  
Incl. VAT.

System accessories  
from page 100



Abrasives  
from page 107



### Antistatic equipment.

The RAS has antistatic equipment fitted so that even removing paint on metal is safe and easy. The equipment protects the sanding dust against static charging.

## Surface treatment

### Rotary sander RAS 180



# RAS 180



#### MMC electronics.

Smooth start-up, controlled speed and a temperature control to protect against overload make the RAS ideal for demanding, continuous use.

#### Large heavy-duty sander.

- ▶ Particularly economical when used over large areas, as the machine is designed for high material removal rates and fast work progress
- ▶ Optimum dust extraction ensures a clean workspace, a clear view and a healthy working environment
- ▶ Health-friendly – anti-static equipment for the reliable removal of clear coats on metal, extraction hood for the perfect extraction of fine dust particles and chips
- ▶ Tool-less sanding pad change

#### Technical data

Power consumption (W)	1500
Idle engine speed (min <sup>-1</sup> )	800-4000
Interchangeable sanding pad Ø (mm)	180
Spindle thread	M14
Connection Ø d/e (mm)	27
weight (kg)	4,2



= with MMC electronics

Items Included	RRP in £*	Order no.
StickFix sanding pad Ø 180, StickFix abrasive discs, extractor hood with handle, operation tool, in a carton		
<b>RAS 180 E GB 240V</b>	567,00 680,40	<b>570747</b>

\* Recommended retail price of manufacturer. Dealer prices may vary.  
Excl. VAT.  
Incl. VAT.

#### System accessories from page 100



#### Abrasives from page 107





# BS 75 / BS 105

## Manoeuvrable belt sander.

- ▶ Perfect sanding of different materials – with stepless control of the belt speed and a sanding base made from graphite or metal with cork backing for fine or coarse sanding
- ▶ Precision adjustment after every belt change for maximum accuracy
- ▶ The well-balanced centre of gravity of the longitudinally mounted motor ensures non-tiring work
- ▶ Perfect system accessories – the belt sanders can be quickly combined with the bench-mounted set for permanent installation in the bodyshop

Technical data	BS 75 E	BS 105 E
Power consumption (W)	1010	1400
Rated belt load (m/min)	200-380	230-380
Belt length x belt width (mm)	533 x 75	620 x 105
Sanding area (mm)	135 x 75	160 x 105
Connection Ø d/e (mm)	27/36	27/36
weight (kg)	3,8	6,5



☐ = with electronics

Items Included	RRP in £*	Order no.
stationary unit, extraction adapter, dust bag, slip band P100, in a SYSTAINER SYS MAXI		
<b>BS 75 E-Plus GB 240V</b>	349,00 418,80	<b>570284</b>
<b>BS 75 E-Set GB 240V</b> surface sanding frame	448,00 537,60	<b>570254</b>
<b>BS 105 E-Plus GB 240V</b>	546,00 655,20	<b>570235</b>
<b>BS 105 E-Set GB 240V</b> surface sanding frame	669,00 802,80	<b>570234</b>

\* Recommended retail price of manufacturer. Dealer prices may vary.  
Excl. VAT.  
Incl. VAT.

System accessories  
from page 101

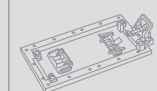

Abrasives  
from page 107



## Smooth touch down.

The sanding frame can be positioned gently and securely, the belt sander does not tilt and is easy to guide.

## Surface treatment

### Belt sander module CMS-BS



# CMS-BS



### Belt sander for the CMS system.

- ▶ Possibility of lowering the sanding belt for full belt utilisation, achieving greater efficiency
- ▶ Quick, simple belt changing – short changeover times
- ▶ Tilting sanding belt for sanding chamfers and sloping surfaces with ease
- ▶ Powerful motor for sanding large areas with minimum effort

#### Technical data

Power consumption (W)	550
Idle engine speed (min <sup>-1</sup> )	2800
Belt length x belt width (mm)	820 x 120
Sanding area (mm)	185 x 115
Connection Ø d/e (mm)	27
Dimensions module support (mm)	578 x 320



Items Included	RRP in £*	Order no.
belt sander module, extraction hood, connecting hose, sanding belt, angle stop, in a carton		
<b>CMS-MOD-BS 120 GB 240V</b>	618,00 741,60	<b>570249</b>

### Open to change.

The CMS Compact Module System consists of a basic unit and compatible modules that transform the unit into a stationary bench-mounted saw, jigsaw, bench-mounted router or belt sander.

\* Recommended retail price of manufacturer. Dealer prices may vary.  
Excl. VAT.  
Incl. VAT.

**CMS system overview**  
from page 348



**System accessories**  
from page 101





### Designed for continuous operation.

Extremely robust, durable and reliable. Ideal for heavy-duty applications in paintshops or the industrial sector because compressed air sanders are low-maintenance and significantly lighter than electric power tools.

The innovative IAS 3 system ensures perfect dust extraction and low vibration levels and lower operating noises maintain a healthy working environment.

### Three times the benefits – the Festool IAS 3 system.

The unique IAS 3 system combines three functions in one hose: compressed air supply, exhaust air extraction and dust extraction. Sanding dust and exhaust air are kept away from the working area, the surface remains clean and the resulting surface finish is excellent. The compressed air tool operates more quietly due to sound absorption elements in the hose. An intelligently designed exhaust air system prevents the discharge of cold air onto the hands and wrists and makes your work more enjoyable and healthier.



1 - Compressed air supply

2 - Exhaust air extraction

3 - Dust extraction

## Surface treatment

Compressed air eccentric sander LEX 3 77



2012

# LEX 3 77



### For extreme durability.

For smooth processes with no machine failures or maintenance.

### For surface finishing.

- ▶ Extremely sturdy design ensures a long service life, minimal servicing requirements and high cost savings
- ▶ Pleasant operating noise, low vibration levels and safe dispersion of exhaust air through a compressed air hose protects the health of the user
- ▶ Sanding pad brake reduces sanding errors when setting down the machine, thereby avoiding rework and additional costs
- ▶ Low compressed air consumption ensures high cost savings

#### Technical data

Operating pressure (flow pressure) (bar)	6
No. of strokes (min <sup>-1</sup> )	21000
Eccentric motion speed (min <sup>-1</sup> )	10500
Sanding stroke (mm)	2,5
Vibration emission value ah (single-axel) (m/s <sup>2</sup> )	0,8
Vibration emission value ah (three-axel) (m/s <sup>2</sup> )	1,9
Air consumption at rated load (l/min)	270
Sanding pad Ø (mm)	77
Sound pressure level (dB(A))	72
weight (kg)	0,7



Items Included	RRP in £*	Order no.
StickFix sanding pad Ø 77 mm W-HT (soft), operation tool, in a carton		
<b>LEX 3 77/2,5</b>	301,00 361,20	<b>691131</b>

The IAS 3 connection system is required to operate the compressed air sanders.

\* Recommended retail price of manufacturer. Dealer prices may vary.  
Excl. VAT.  
Incl. VAT.

#### System accessories from page 102



#### Abrasives from page 107







# LEX 3 125

## Saves compressed air without affecting results.

- ▶ Low compressed air consumption ensures high cost savings
- ▶ Low vibration levels and a pleasant operating noise protect the user's health
- ▶ Sanding pad brake reduces sanding errors when setting down the machine, thereby avoiding rework and additional costs



## No possibility of confusion.

Clearly visible stroke indicator on the dead-man switch of all LEX 3 models makes it easy to select the correct machine.

Technical data	LEX 3 125/3	LEX 3 125/5
Operating pressure (flow pressure) (bar)	6	6
No. of strokes (min <sup>-1</sup> )	19000	19000
Eccentric motion speed (min <sup>-1</sup> )	9500	9500
Sanding stroke (mm)	3	5
Vibration emission value ah (single-axel) (m/s <sup>2</sup> )	1,1	1,1
Vibration emission value ah (three-axel) (m/s <sup>2</sup> )	3,6	4,2
Air consumption at rated load (l/min)	290	290
Sound pressure level (dB[A])	70	72
Sanding pad Ø (mm)	125	125
weight (kg)	0,9	0,95



Items Included	RRP in £*	Order no.
operation tool, in a carton		
<b>LEX 3 125/3</b>	451,00	<b>691140</b>
StickFix sanding pad Ø 125 mm (extra soft)	541,20	
<b>LEX 3 125/5</b>	451,00	<b>691141</b>
StickFix sanding pad Ø 125 mm (soft-HT)	541,20	

The IAS 3 connection system is required to operate the compressed air sanders.

\* Recommended retail price of manufacturer. Dealer prices may vary.  
Excl. VAT.  
Incl. VAT.

### System accessories from page 102



### Abrasives from page 107



## Surface treatment

Compressed air eccentric sander LEX 3 150



1913



# LEX 3 150



### Stops vibrations. Increases efficiency.

- ▶ Precise – sanding pad brake ensures a clean pattern
- ▶ Low compressed air consumption ensures high cost savings
- ▶ High-quality FUSION-TEC sanding pads and the MULTI-JETSTREAM principle for perfect dust extraction and economical abrasive consumption
- ▶ Vibrations stop for healthy, non-tiring work

Technical data	LEX 3 150/3	LEX 3 150/5	LEX 3 150/7
Operating pressure (flow pressure) (bar)	6	6	6
No. of strokes (min <sup>-1</sup> )	20000	20000	20000
Eccentric motion speed (min <sup>-1</sup> )	10000	10000	10000
Sanding stroke (mm)	3	5	7
Vibration emission value ah (single-axel) (m/s <sup>2</sup> )	2,1	2,7	3,17
Vibration emission value ah (three-axel) (m/s <sup>2</sup> )	3,7	3,9	5,8
Air consumption at rated load (l/min)	290	290	310
Sound pressure level [dB(A)]	72	72	76
Sanding pad Ø (mm)	150	150	150
weight (kg)	1,0	1,0	1,0



### Safe and healthy.

The non-slip softgrip cap on the LEX 3 provides a secure hold. Dust extraction with MULTI-JETSTREAM principle keeps the air and workpiece clean.

Items Included	RRP in £*	Order no.
operation tool, in a carton		
<b>LEX 3 150/3</b> StickFix sanding pad Ø 150 mm FUSION-TEC (extra-soft)	451,00 541,20	<b>691137</b>
<b>LEX 3 150/5</b> StickFix sanding pad Ø 150 mm FUSION-TEC (soft HT)	451,00 541,20	<b>691138</b>
<b>LEX 3 150/7</b> StickFix sanding pad Ø 150 mm FUSION-TEC (soft HT)	451,00 541,20	<b>691139</b>

The IAS 3 connection system is required to operate the compressed air sanders.

\* Recommended retail price of manufacturer. Dealer prices may vary.  
Excl. VAT.  
Incl. VAT.

#### System accessories from page 102



#### Abrasives from page 107

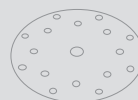



# LEX 2 185/7



### Specialist in material removal.

- ▶ Dead-man switch for safe work
- ▶ Clearly visible stroke indicator
- ▶ Sanding pad brake gives a clean pattern
- ▶ Vibrations stop for healthy, non-tiring work

#### Technical data

Operating pressure (flow pressure) (bar)	6
No. of strokes (min <sup>-1</sup> )	16000
Eccentric motion speed (min <sup>-1</sup> )	8000
Sanding stroke (mm)	7
Air consumption at rated load (l/min)	390
Sanding pad Ø (mm)	185
weight (kg)	1,4



Items Included	RRP in £*	Order no.
StickFix sanding pad Ø 185 mm (soft), bottle cleaning and lubricating oil LD-10 (50 ml), operation tool, in a carton		
<b>LEX 2 185/7</b>	453,00 543,60	<b>692096</b>

### Softgrip cap.

The Softgrip coating on the tool ensures easy machine guidance with no slipping.

The IAS 3 connection system is required to operate the compressed air sanders.

\* Recommended retail price of manufacturer. Dealer prices may vary.  
Excl. VAT.  
Incl. VAT.

#### System accessories from page 102



#### Abrasives from page 107



## Surface treatment

Compressed air orbital sander LRS 93

# LRS 93



### Vibration stop.

Less stress on your hands and wrists. VS balancing reduces vibrations and oscillations, and is kind to both you and your machine.

### Perfect for flat surfaces.

- ▶ Machine is easy to guide
- ▶ Speed and stroke preselection
- ▶ Vibrations stop for healthy, non-tiring work
- ▶ Robust vane motor for a long service life

#### Technical data

Operating pressure (flow pressure) (bar)	6
No. of strokes (min <sup>-1</sup> )	14000
Sanding stroke (mm)	4
Air consumption at rated load (l/min)	310
Sanding pad StickFix (mm)	93 x 175
weight (kg)	1,2



Items Included	RRP in £*	Order no.
StickFix sanding pad 93 x 175 mm (soft), bottle cleaning and lubricating oil LD-10 (50 ml), in a carton		
<b>LRS 93 M</b>	407,00 488,40	<b>692049</b>

The IAS 3 connection system is required to operate the compressed air sanders.

\* Recommended retail price of manufacturer. Dealer prices may vary.  
Excl. VAT.  
Incl. VAT.

**System accessories**  
from page 104

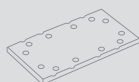

**Abrasives**  
from page 107

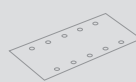



# LRS 400

## Long sander for large surfaces.

- ▶ Lightweight and handy despite its size
- ▶ High material removal rate on large, flat surfaces
- ▶ Vibrations stop for healthy, non-tiring work
- ▶ Robust vane motor for a long service life

### Technical data

Operating pressure (flow pressure) (bar)	6
No. of strokes (min <sup>-1</sup> )	14000
Sanding stroke (mm)	4
Air consumption at rated load (l/min)	390
Sanding pad StickFix (mm)	80 x 400
weight (kg)	2,3



## Easy guidance.

All compressed air orbital sanders are easy to guide, both with one or two hands. The Softgrip and the additional handle on the LRS 400 give you complete control of the machine.

Items Included	RRP in £*	Order no.
StickFix sanding pad 80 x 400 mm (soft), bottle cleaning and lubricating oil LD-10 (50 ml), in a carton		
<b>LRS 400</b>	501,00 601,20	<b>692099</b>

The IAS 3 connection system is required to operate the compressed air sanders.

\* Recommended retail price of manufacturer. Dealer prices may vary.  
Excl. VAT.  
Incl. VAT.

### System accessories from page 104

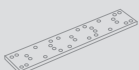

### Abrasives from page 107

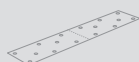

## Surface finishing



### Oil application in its cleanest form.

Festool also offers a fully adapted system for producing a perfectly oiled surface finish – the SURFIX oil dispenser provides quick, clean and ecological surface protection of the highest quality in combination with high-quality natural oils.

### Detail of success.

Festool creates a perfect interaction between machine, polishing pad, foam pad and abrasive: for sensitive working and gleaming results on different materials from the wood go, without any rework. For high-gloss paints, UV clear coats, mineral materials or acrylic glass.



Sustainable, high-quality ingredients – Festool natural oils.

### HEAVY-DUTY

Protection for furniture, worktops and all heavily worn indoor surfaces: HEAVY-DUTY special oil

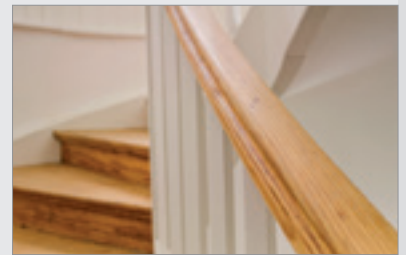

### ONE-STEP

A gleaming finish and smooth to the touch: the ONE-STEP oil/wax mixture for decorative indoor surfaces.

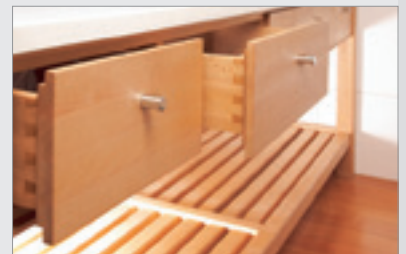

### OUTDOOR

OUTDOOR universal oil is ideal for weatherproofing all types of wood used in external applications.



## Surface treatment

### Rotary polisher RAP 80

02



# RAP 80



#### Specialist for small surfaces.

- ▶ The slimline, compact design, practical dome grip and low weight ensure relaxed working
- ▶ Robust – overload protection effectively prevents motor damage
- ▶ Perfect for small, curved surfaces or areas with limited access – the RAP 80 rests snugly in the hand and is easy to guide

#### Technical data

Power consumption (W)	500
Idle engine speed (min <sup>-1</sup> )	750-2300
Maximum polishing pad Ø (mm)	80
Spindle thread	M14
weight (kg)	1,6



= with MMC electronics

#### Slim and compact.

The dome grip on the RAP 80.02 E is designed "around your hand", the weight is distributed perfectly and the ergonomically shaped side handle always guarantees a firm grip when you guide the machine.

Items Included	RRP in £*	Order no.
StickFix polishing pad Ø 80 mm, additional side-mounted hand grip, in a carton		
<b>RAP 80.02 E GB 240V</b>	311,00 373,20	<b>570749</b>

\* Recommended retail price of manufacturer. Dealer prices may vary.  
Excl. VAT.  
Incl. VAT.

#### System accessories from page 125

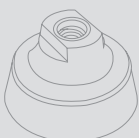

#### Abrasives from page 128

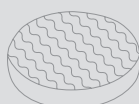

## Surface treatment

### Rotary polisher SHINEX RAP 150



product  
design  
award

2009



# SHINEX RAP 150



### All-purpose genius.

- ▶ Variable speed trigger for sensitive starting and acceleration depending on the torque setting (400-2100 revolutions per minute)
- ▶ 2-speed gear unit is powerful, sturdy and durable across the entire speed range
- ▶ Long service life – a temperature-dependent overload protection and filter catcher protect the machine
- ▶ Work for longer periods – only weighs 2.1 kg, ergonomic design and perfectly balanced

#### Technical data

Power consumption [W]	1200
Idle engine speed [min <sup>-1</sup> ]	400-2100
Maximum polishing pad Ø [mm]	150
Spindle thread	M14
weight [kg]	2,1



= with MMC electronics

Items Included	RRP in £*	Order no.
additional side-mounted hand grip, StickFix polishing pad Ø 150 mm		
<b>RAP 150 FE GB 240V</b> in a carton	378,00 453,60	<b>570767</b>
<b>RAP 150 FE GB 110V</b> in a carton	378,00 453,60	<b>570778</b>
<b>RAP 150 FE-Set Wood</b> self-adhesive sanding disc assortment Titan 2, StickFix sanding disc assortment, spot sander, polish MPA 5000/1, polish MPA 8000, PoliStick Ø 150 mm polishing sponge, orange, medium, PoliStick Ø 150 mm foam polishing pad, black, extra fine, PoliStick Ø 150 mm premium sheepskin, 2 microfibre cloths, finish cleaner, in a SYSTAINER SYS MAXI	495,00 594,00	<b>570795</b>

### Precise application of power.

Perfect power transfer thanks to the minimum distance between the tool and pad and the various grip positions of the SHINEX RAP 150.

\* Recommended retail price of manufacturer. Dealer prices may vary.  
Excl. VAT.  
Incl. VAT.

#### System accessories from page 125

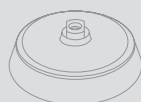

#### Abrasives from page 128

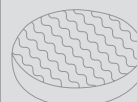





# POLLUX 180



### Powerhouse with high coverage capacity.

- ▶ Improved cooling in lower speed range and temperature-dependent overload protection allow work under heavy loads
- ▶ Controlled speed, stepless speed preselection and smooth start-up for adaptation to the working surface
- ▶ Variable speed trigger with slow start function
- ▶ Ergonomic dome grip and perfect weight distribution for relaxed work

#### Technical data

Power consumption (W)	1500
Idle engine speed (min <sup>-1</sup> )	800-2400
Maximum polishing pad Ø (mm)	180
Spindle thread	M14
weight (kg)	3,6



= with MMC electronics

### When faced with demanding tasks.

The POLLUX 180 E enables perfect adaptation to different materials and surfaces. The motor speed always remains constant thanks to the MMC electronics and allows you to work evenly without damaging the workpiece and avoid time-consuming reworking.

Items Included	RRP in £*	Order no.
StickFix polishing pad Ø 180 mm, additional side-mounted hand grip, in a carton		
<b>POLLUX 180 E GB 240V</b>	424,00 508,80	<b>570751</b>

\* Recommended retail price of manufacturer. Dealer prices may vary.  
Excl. VAT.  
Incl. VAT.

#### System accessories from page 125



#### Abrasives from page 126



## Surface treatment

### SURFIX OS oil dispenser



product  
design award

2012

# SURFIX OS



### Safe and clean.

The foam pad remains soft and reusable for long periods when stored in the tin provided.

### Oil application in its cleanest form.

- ▶ Quick and ergonomic – the full oil bottle clicks into the base plate and is used as a handgrip.
- ▶ Pressing down on the bottle controls the flow of oil, which is then distributed evenly using the foam pad
- ▶ Clean and economical – the foam pad absorbs surplus oil and redistributes it to the right place
- ▶ For every application area – Heavy-Duty, One-Step and Outdoor oil grades for all interior and exterior applications and light or dark woods. All high-quality natural oils, free of solvents and ecologically safe

Items Included	RRP in £*	Order no.
base plate		
<b>OS-Set HD 0,3 l</b> heavy-duty oil bottle, 0.3 l, StickFix oil sponge, In white tin	26,75 32,10	<b>498060</b>
<b>OS-Set OS 0,3 l</b> one-step oil bottle, 0.3 l, StickFix oil sponge, In white tin	26,75 32,10	<b>498061</b>
<b>OS-Set OD 0,3 l</b> outdoor oil bottle, 0.3 l, StickFix oil sponge, In white tin	26,75 32,10	<b>498062</b>
<b>OS-SYS3-Set</b> Oil dispenser OS-Set HD 0,3l, one-step oil bottle, 0.3 l, outdoor oil bottle, 0.3 l, 5x oil sponges, 5x green sanding cloths, 5x white sanding cloths, 10x STF-D150 P180 RU2 sanding discs, 10x STF-D150 P240 BR2 sanding discs, in a SYSTAINER SYS 3 T-LOC	113,15 135,78	<b>498063</b>

\* Recommended retail price of manufacturer. Dealer prices may vary.  
Excl. VAT.  
Incl. VAT.

### System accessories from page 133



### More on natural oils from page 84





# RUSTOFIX BMS 180



## Quick, fix, RUSTOFIX.

- ▶ Three working steps with one tool: Texturing, intermediate sanding and smoothing
- ▶ Adjustable support rollers for precise setting of the texturing depth
- ▶ Quick, easy brush changes
- ▶ Overload protection for a long service life

### Technical data

Power consumption (W)	1500
Idle engine speed (min <sup>-1</sup> )	800-4000
Tool Ø (mm)	150
Spindle thread	M14
Connection Ø d/e (mm)	27
weight (kg)	7,5



= with MMC electronics

## The quick way to produce a rustic wood effect.

The RUSTOFIX is the perfect tool for anyone wishing to lend a rustic touch to wooden surfaces – as safe and economically efficient as possible. Whether in furniture manufacture, building renovation or timber restoration.

Items Included	RRP in £*	Order no.
LD 85 brush, KB 80 brush, extractor hood with handle, tool arbour, clamping flange, operation tool, in the case		
<b>BMS 180 E GB</b>	796,00 955,20	<b>570748</b>

\* Recommended retail price of manufacturer. Dealer prices may vary.  
Excl. VAT.  
Incl. VAT.

### System accessories from page 106

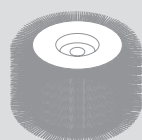

### The Festool system.

Because things work better when everything fits together:  
When sanding, for example. Almost all Festool abrasives and sanding pads are changed without requiring tools and adapted perfectly to the relevant sander as well as the overall system.



## Surface treatment

Accessories and consumable materials

### Sanding

System accessories	92
Abrasives	107

### Polishing

System accessories	124
Polishing agent	126
Foam polishing pads	128

### Oils

System accessories	133
--------------------	-----



## Surface treatment

### System accessories

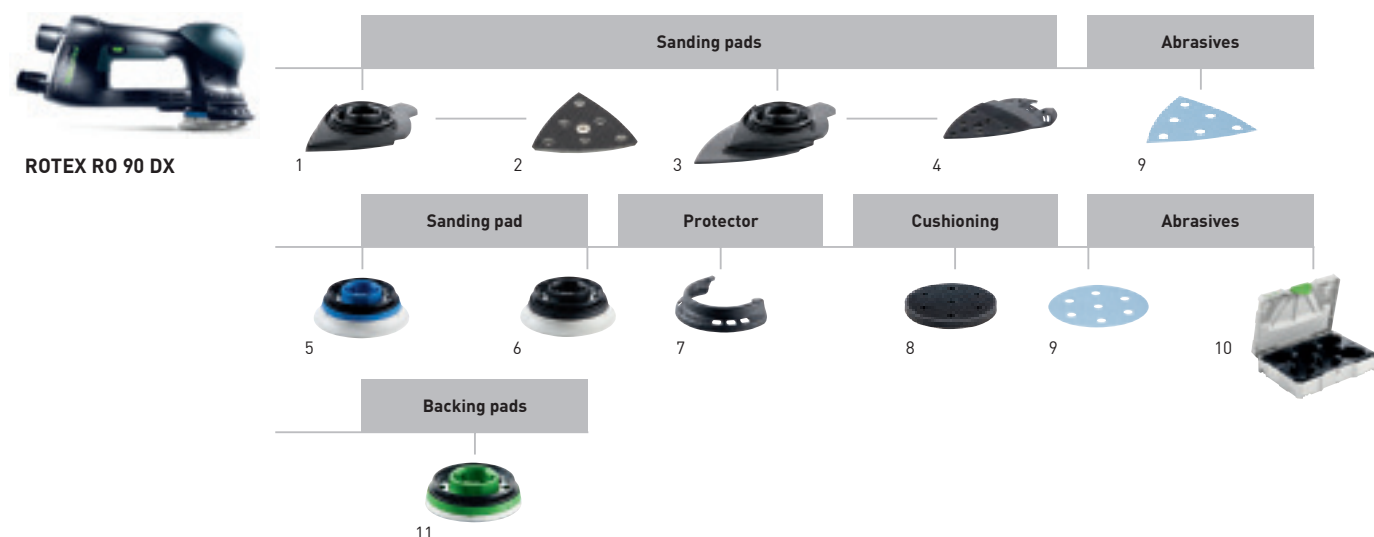

### Accessories for geared eccentric sander ROTEX RO 90 DX

Denomination	Explanation	RRP in £*	Order no.
1 Sanding pad SSH-GE-STF-R090 DX	suitable for abrasive 93 V, delta sanding pad, for attaching StickFix sanding pad, soft and hard, plate without interchangeable sanding pad, connecting thread FastFix, qty. in pack 1 piece(s), in self-service display pack	20,70 24,84	496802
2 Sanding pad StickFix, soft SSH-STF-V93/6-W/2	for DX 93 and RO 90 DX, StickFix, with snap stud, qty. in pack 2 piece(s), hardness grade W, in self-service display pack	12,25 14,70	488715
Sanding pad StickFix, hard SSH-STF-V93/6-H/2	for DX 93 and RO 90 DX, StickFix, with snap stud, qty. in pack 2 piece(s), hardness grade H, in self-service display pack	12,25 14,70	488716
3 Sanding pad LSS-STF-R090 V93/6	suitable for abrasive 93 V, slat sanding pad V93, plate incl. interchangeable sanding pad, for sanding in tight spaces, in self-service display pack	25,40 30,48	496803
4 Sanding pad LSS-STF-R090 V93 E	replacement backing pad for slat sanding pad, in self-service display pack	12,80 15,36	497483
5 FastFix sanding pad dia ST-STF D90/7 FX H-HT	hard version, high temperature durability burr, for plain surfaces and narrow edges, hardness grade H-HT, connecting thread FastFix, qty. in pack 1 piece(s), in self-service display pack	25,40 30,48	495623
6 FastFix sanding pad dia ST-STF D90/7 FX W-HT	soft version, high temperature durability burr, for universal use on plain and arced surfaces, hardness grade W-HT, connecting thread FastFix, qty. in pack 1 piece(s), in self-service display pack	25,40 30,48	496804
7 Protector set FP-RO 90	for RO 90 DX, window protectors S, M, L, qty. in pack 3 piece(s), in self-service display pack	24,45 29,34	497936
8 Interface pad IP-STF-D90/6	Interface pad D 90 mm, height 15 mm, as damping element between sanding disc and sanding pad, Height 15 mm, qty. in pack 1 piece(s), Diameter 90 mm, in self-service display pack	6,55 7,86	497481
9 Abrasives	from page 107		
10 SYSTAINER SYS-STF-D77/D90/93V	with insert for Ø 90 mm abrasives and 93V abrasives, number of compartments 8, systainer size SYS 1 T-LOC	44,55 53,46	497687
11 FastFix polishing pad PT-STF-D90 FX-R090	for RO 90 DX, for holding polishing accessories with dia. 80 mm, Diameter 75 mm, in self-service display pack	25,40 30,48	495625



ROTEX RO 125

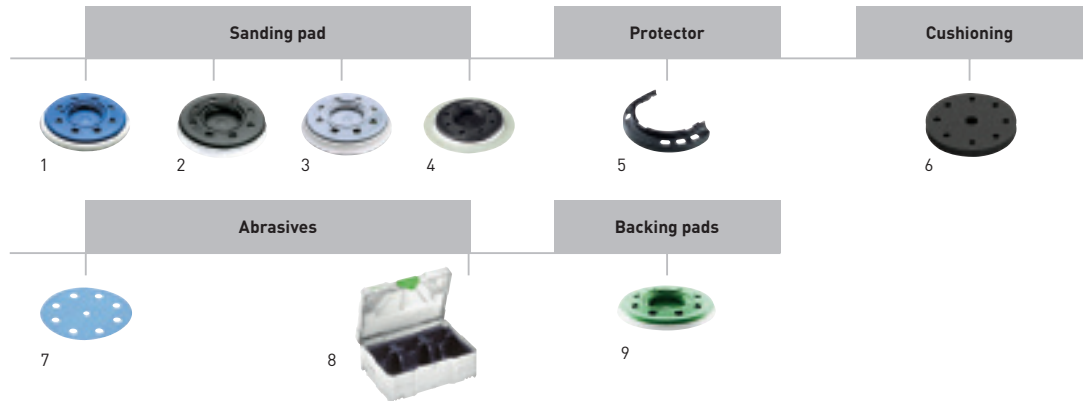

### Accessories for geared eccentric sander ROTEX RO 125

Denomination	Explanation	RRP in £*	Order no.
1 <b>FastFix sanding pad dia ST-STF D125/8 FX-H-HT</b>	hard version, high edge solidity, high temperature durability burr, for plain surfaces and narrow edges, hardness grade H-HT, connecting thread FastFix, qty. in pack 1 piece(s), in self-service display pack	31,35 37,62	<b>492127</b>
2 <b>FastFix sanding pad dia ST-STF D125/8 FX-W-HT</b>	soft version, for universal use on plain and arced surfaces, high temperature durability burr, hardness grade W-HT, connecting thread FastFix, qty. in pack 1 piece(s), in self-service display pack	31,35 37,62	<b>492125</b>
3 <b>FastFix sanding pad dia ST-STF D125/8 FX-SW</b>	ultra-soft version, elastic structure, for heavy roundings and cambers, hardness grade SW, connecting thread FastFix, qty. in pack 1 piece(s), in self-service display pack	31,35 37,62	<b>492126</b>
4 <b>FastFix louver pad LT-STF D125/RO125</b>	for sanding louvers, Diameter 150 mm, in self-service display pack	32,95 39,54	<b>492129</b>
5 <b>Protector FESTOOL 125FX</b>	for RO 125 FEQ, for protecting the sanding pad and workpiece, in self-service display pack	8,40 10,08	<b>493912</b>
6 <b>Interface pad IP-STF-D120/90/8</b>	for ES 125, ETS 125as damping element between sanding disc and sanding pad, for sanding contoured parts and fine-sanding parts with eccentric sander Ø 125 mm, Height 15 mm, Diameter 120 mm, diameter of jet stream holes 90 mm, qty. in pack 1 piece(s), in self-service display pack	8,00 9,60	<b>492271</b>
7 <b>Abrasives</b>	from page 107		
8 <b>SYSTAINER T-LOC SYS-STF D125</b>	with insert for abrasives Ø 125 mm, number of compartments 5, systainer size SYS 1 T-LOC	45,05 54,06	<b>497685</b>
9 <b>FastFix polishing pad PT-STF-D125 FX-RO125</b>	for RO 125 FEQ, fits polishing accessories, Diameter 115 mm, Height 10 mm, in self-service display pack	18,05 21,66	<b>492128</b>

## Surface treatment

### System accessories

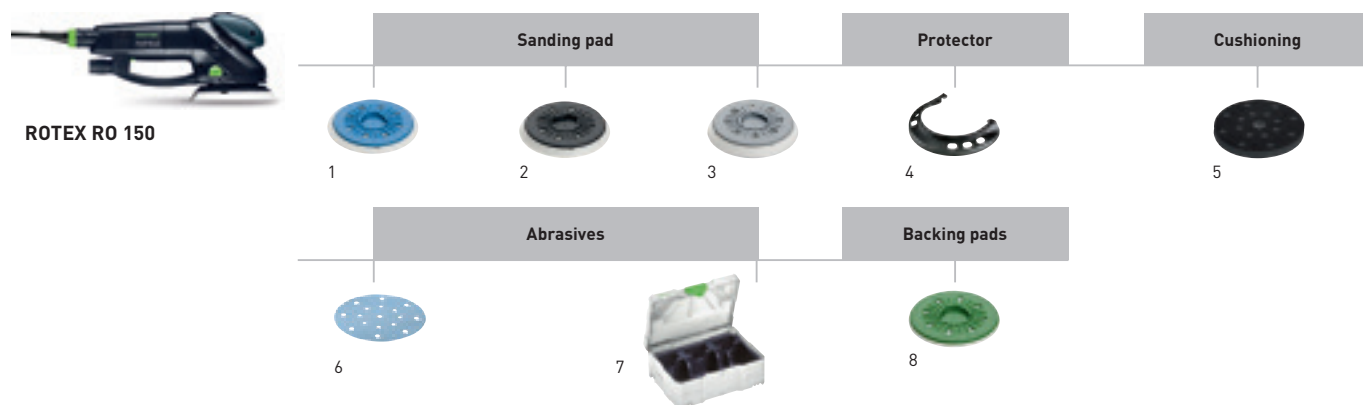

### Accessories for geared eccentric sander ROTEX RO 150

Denomination	Explanation	RRP in €*	Order no.
1 <b>FastFix sanding pad dia ST-STF D150/17MJ-FX-H-HT</b>	hard version, MULTI-JETSTREAM, high temperature durability burr, high edge solidity, for plain surfaces and narrow edges, hardness grade H-HT, connecting thread FastFix, qty. in pack 1 piece(s), in self-service display pack	37,60	<b>496149</b>
		45,12	
2 <b>FastFix sanding pad dia ST-STF D150/17MJ-FX-W-HT</b>	soft version, MULTI-JETSTREAM, high temperature durability burr, for universal use on plain and arced surfaces, hardness grade W-HT, connecting thread FastFix, qty. in pack 1 piece(s), in self-service display pack	37,60	<b>496147</b>
		45,12	
3 <b>FastFix sanding pad dia ST-STF D150/17MJ-FX-SW</b>	ultra-soft version, MULTI-JETSTREAM, elastic structure, for heavy roundings and cambers, hardness grade SW, connecting thread FastFix, qty. in pack 1 piece(s), in self-service display pack	37,60	<b>496144</b>
		45,12	
4 <b>Protector FESTOOL 150FX</b>	for RO 150 FEQ, for protecting the sanding pad and workpiece, in self-service display pack	10,55	<b>493913</b>
		12,66	
5 <b>Interface pad IP-STF D 150/17 MJ-S2x</b>	for eccentric sander with diameter of 150 mm, as damping element between sanding disc and sanding pad, MULTI-JETSTREAM, optimal thickness for sanding work on bodies and similarly shaped components, Diameter 145 mm, Height 5 mm, qty. in pack 2 piece(s), in self-service display pack	15,90	<b>499257</b>
		19,08	
<b>Interface pad IP-STF D 150/17 MJ</b>	for eccentric sander with diameter of 150 mm, as damping element between sanding disc and sanding pad, MULTI-JETSTREAM, optimal thickness for sanding work on curved components, Height 15 mm, Diameter 145 mm, in self-service display pack	10,15	<b>496647</b>
		12,18	
6 <b>Abrasives</b>	from page 107		
7 <b>SYSTAINER T-LOC SYS-STF D150</b>	with insert for abrasives Ø 150 mm, number of compartments 10, systainer size SYS 3 T-LOC	52,60	<b>497690</b>
		63,12	
8 <b>FastFix polishing pad PT-STF-D150 FX</b>	for RO 150 FEQ, fits polishing accessories, Diameter 135 mm, Height 10 mm, in self-service display pack	25,30	<b>496151</b>
		30,36	



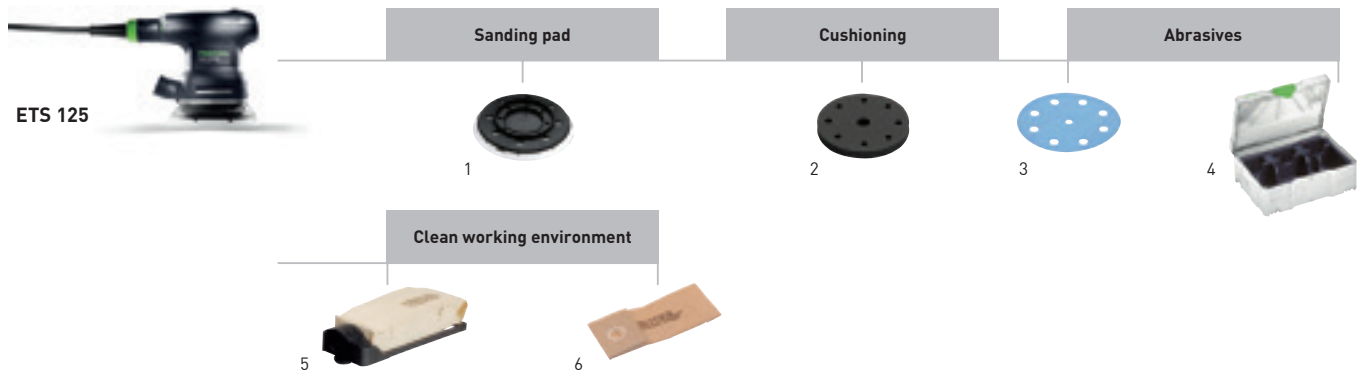

### Accessories for eccentric sander ETS 125

Denomination	Explanation	RRP in €*	Order no.
1 Sanding pad ST-STF ES125/90/8-M4 W-HT	for ES 125, ETS 125soft version, for universal use on plain and arced surfaces, high temperature durability burr, for robust use with grit up to P220, connecting thread M4, diameter of jet stream holes 90 mm, hardness grade W-HT, qty. in pack 1 piece(s), in self-service display pack	38,00	492280
		45,60	
Sanding pad ST-STF ES125/90/8-M4 SW	for ES 125, ETS 125ultra-soft version, elastic structure, for heavy roundings and cambers, connecting thread M4, diameter of jet stream holes 90 mm, hardness grade SW, qty. in pack 1 piece(s), in self-service display pack	38,00 45,60	492282
2 Interface pad IP-STF-D120/90/8	for ES 125, ETS 125as damping element between sanding disc and sanding pad, for sanding contoured parts and fine-sanding parts with eccentric sander Ø 125 mm, Height 15 mm, Diameter 120 mm, diameter of jet stream holes 90 mm, qty. in pack 1 piece(s), in self-service display pack	8,00 9,60	492271
3 Abrasives	from page 107		
4 SYSTAINER T-LOC SYS-STF D125	with insert for abrasives Ø 125 mm, number of compartments 5, systainer size SYS 1 T-LOC	45,05 54,06	497685
5 Turbo filter bag set TFS-RS 400	for RS 400, RTS 400, DS 400, DTS 400, ES 125, ETS 125, for clear view and healthy working environment, filter cartridge, 5 turbofilters, in self-service display pack	18,05	489129
		21,66	
6 Turbo filter bag TF-RS 400/25	for RS 400, RTS 400, DS 400, DTS 400, ES 125, ETS 125, for insertion in filter cartridge, qty. in pack 25 piece(s), in a carton	29,80	489127
		35,76	
Turbo filter bag TF-RS 400/5	for RS 400, RTS 400, DS 400, DTS 400, ES 125, ETS 125, for insertion in filter cartridge, qty. in pack 5 piece(s), in self-service display pack	7,20 8,64	489128

## Surface treatment

### System accessories

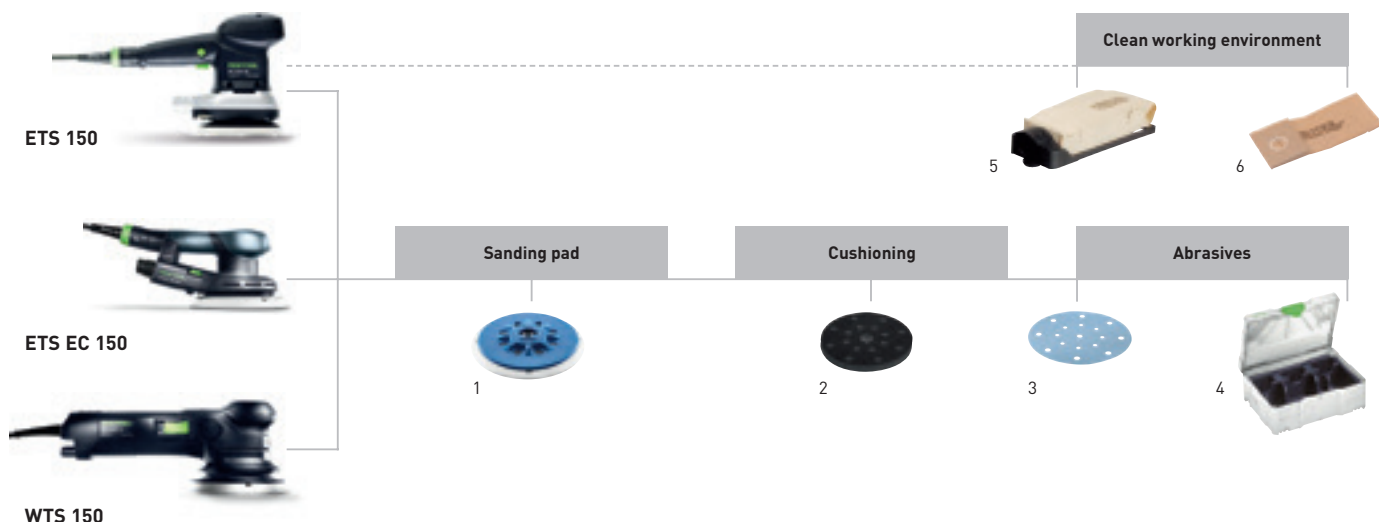

#### Accessories for eccentric sanders ETS 150, ETS EC 150, WTS 150

Denomination	Explanation	RRP in £*	Order no.
<b>1 Sanding pad</b> ST-STF D150/17FT-M8-H-HT	for ETS 150, ETS EC 150, LEX 3 150 and WTS 150/7, hard version, MULTI-JETSTREAM, high temperature durability burr, high edge solidity, for flat surfaces, hardness grade H-HT, connecting thread M8, qty. in pack 1 piece(s), in self-service display pack	42,70 51,24	<b>498988</b>
<b>Sanding pad</b> ST-STF D150/17FT-M8-W-HT	for ETS 150, ETS EC 150, LEX 3 150 and WTS 150/7, soft version, MULTI-JETSTREAM, high temperature durability burr, high edge solidity, for tough and universal use, hardness grade W-HT, connecting thread M8, qty. in pack 1 piece(s), in self-service display pack	42,70 51,24	<b>498987</b>
<b>Sanding pad</b> ST-STF D150/17FT-M8-SW	for ETS 150, ETS EC 150, LEX 3 150 and WTS 150/7, ultra-soft version, MULTI-JETSTREAM, elastic structure, for heavy roundings and cambers, hardness grade SW, connecting thread M8, qty. in pack 1 piece(s) in self-service display pack	42,70 51,24	<b>498986</b>
<b>2 Interface pad</b> IP-STF D 150/17 MJ-S2x	for eccentric sander with diameter of 150 mm, as damping element between sanding disc and sanding pad, MULTI-JETSTREAM, optimal thickness for sanding work on bodies and similarly shaped components, Diameter 145 mm, Height 5 mm, qty. in pack 2 piece(s), in self-service display pack	15,90 19,08	<b>499257</b>
<b>Interface pad</b> IP-STF D 150/17 MJ	for eccentric sander with diameter of 150 mm, as damping element between sanding disc and sanding pad, MULTI-JETSTREAM, optimal thickness for sanding work on curved components, Height 15 mm, Diameter 145 mm, in self-service display pack	10,15 12,18	<b>496647</b>
<b>3 Abrasives</b>	from page 107		
<b>4 SYSTAINER T-LOC SYS-STF D150</b>	with insert for abrasives Ø 150 mm, number of compartments 10, systainer size SYS 3 T-LOC	52,60 63,12	<b>497690</b>
<b>5 Turbo filter bag set TFS-ES 150</b>	for ES 150, ETS 150, for clear view and healthy working environment, filter cartridge, turbofilter, in self-service display pack	19,95 23,94	<b>489631</b>
<b>6 Turbo filter bag TF II-RS/ES/ET/25</b>	for RS 300, RS 3, RS 200, RS 2, ES 150, ETS 150, ET 2, for insertion in filter cartridge, qty. in pack 25 piece(s), in a carton	26,30 31,56	<b>487871</b>
<b>Turbo filter bag TF II-RS/ES/ET/5</b>	for RS 300, RS 3, RS 200, RS 2, ES 150, ETS 150, ET 2, for insertion in filter cartridge, qty. in pack 5 piece(s), in self-service display pack	6,45 7,74	<b>487779</b>

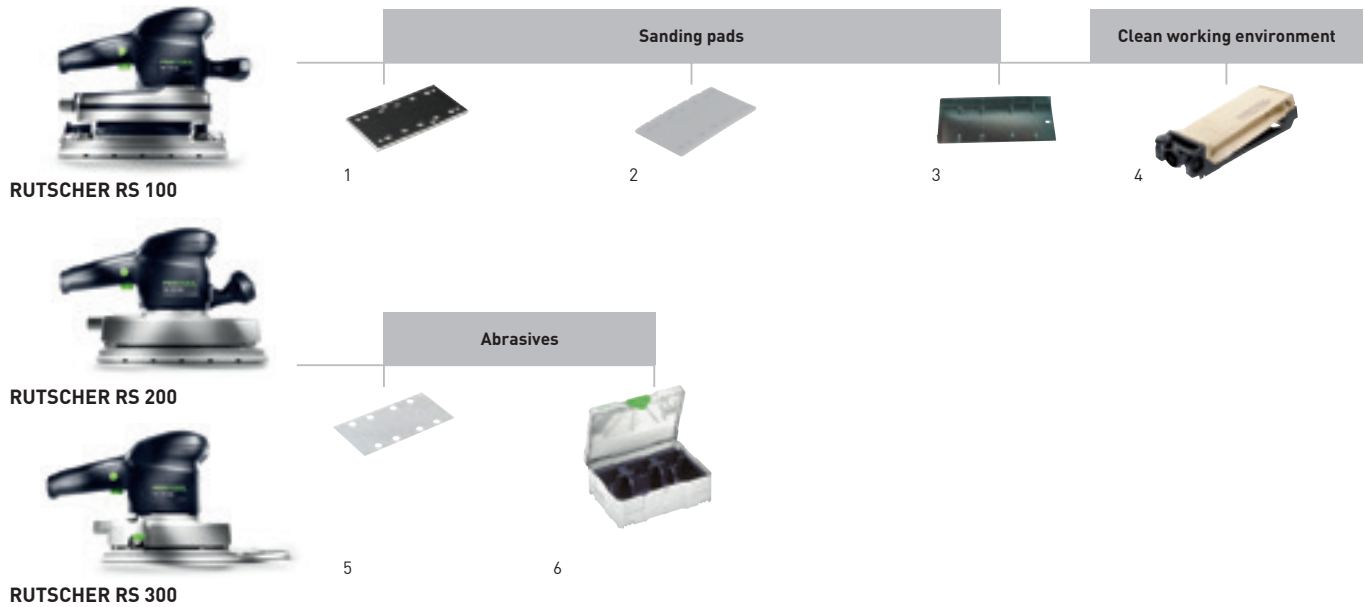

### Accessories for RUTSCHER RS 100, RS 200, RS 300

Denomination	Explanation	RRP in £*	Order no.
<b>1 Sanding pad StickFix SSH-STF-115x221/10 RS 1 C</b>	for RS 100 C, RS 1 C, StickFix adhesive layer for quick change of sanding pad, dimensions 115 x 221 mm, in self-service display pack	27,75 33,30	<b>488226</b>
<b>Sanding pad StickFix SSH-STF-115x225/10</b>	for RS 200, RS 2, RS 100, RS 1, StickFix adhesive layer for quick change of sanding pad, dimensions 115 x 225 mm, in self-service display pack	27,75 33,30	<b>483679</b>
<b>Sanding pad StickFix SSH-STF-115x225/10-KS</b>	for RS 200, RS 2, RS 100, RS 1, with edge protection, dimensions 115 x 225 mm, in self-service display pack	31,45 37,74	<b>485648</b>
<b>Sanding pad StickFix SSH-STF-93x175/8</b>	for RS 300, RS 3, LRS 93, StickFix adhesive layer for quick change of sanding pad, dimensions 93 x 175 mm, in self-service display pack	23,65 28,38	<b>483905</b>
<b>Sanding pad StickFix SSH-STF-L93x230/0</b>	for RS 300, RS 3, LRS 93, lamellar sanding pad version, dimensions 93 x 230 mm, in self-service display pack	26,20 31,44	<b>486371</b>
<b>Sanding pad StickFix SSH-STF-V93x266/14</b>	for RS 300, RS 3, LRS 93, pressing iron sanding pad version, dimensions 93 x 266 mm, in self-service display pack	33,75 40,50	<b>486418</b>
<b>2 Sanding pad SSH-115x225/10</b>	for RS 200, RS 2, RS 100, RS 1, for abrasives for clamping, dimensions 115 x 225 mm, in self-service display pack	24,45 29,34	<b>489629</b>
<b>Sanding pad SSH-115x225/10-KS</b>	for RS 200, RS 2, RS 100, RS 1, with edge protection, for abrasives for clamping, dimensions 115 x 225 mm, in self-service display pack	27,25 32,70	<b>485647</b>
<b>Sanding pad SSH-93x175/8</b>	for RS 300, RS 3, LRS 93, for abrasives for clamping, dimensions 93 x 175 mm, in self-service display pack	20,50 24,60	<b>489630</b>
<b>3 Hole punch 10L 115x225</b>	for RS 200, RS 2, RS 100, RS 100 C, RS 1, RS 1 C, HSK 115 x 226, for preparing the Festool hole pattern, no. of holes 10, in self-service display pack	21,35 25,62	<b>481523</b>
<b>Hole punch 8L 93x175</b>	for RS 300, RS 3, LRS 93, for preparing the Festool hole pattern, no. of holes 8, dimensions 93 x 175 mm, in self-service display pack	18,05 21,66	<b>481903</b>
<b>4 Turbo filter bag TF-RS 1/5</b>	for RS 100, RS 1, qty. in pack 5 piece(s), in self-service display pack	7,45 8,94	<b>483674</b>
<b>Turbo filter bag TF II-RS/ES/ET/25</b>	for RS 300, RS 3, RS 200, RS 2, ES 150, ETS 150, ET 2, for insertion in filter cartridge, qty. in pack 25 piece(s), in a carton	26,30 31,56	<b>487871</b>
<b>Turbo filter bag TF II-RS/ES/ET/5</b>	for RS 300, RS 3, RS 200, RS 2, ES 150, ETS 150, ET 2, for insertion in filter cartridge, qty. in pack 5 piece(s), in self-service display pack	6,45 7,74	<b>487779</b>
<b>Turbo filter bag set TFS II-ET/RS</b>	for RS 300, RS 3, RS 200, RS 2, ET2, for clear view and healthy working environment, filter cartridge, 5 turbofilters, in self-service display pack	19,95 23,94	<b>487780</b>
<b>5 Abrasives</b>	from page 107		
<b>6 SYSTAINER T-LOC SYS-STF 115x228</b>	with insert for abrasives 115x228mm, number of compartments 6, systainer size SYS 2 T-LOC	48,90 58,68	<b>497688</b>
<b>SYSTAINER T-LOC SYS-STF 93x178/93V</b>	with insert for abrasives 93x178mm, number of compartments 6, systainer size SYS 2 T-LOC	48,90 58,68	<b>497689</b>

## Surface treatment

### System accessories

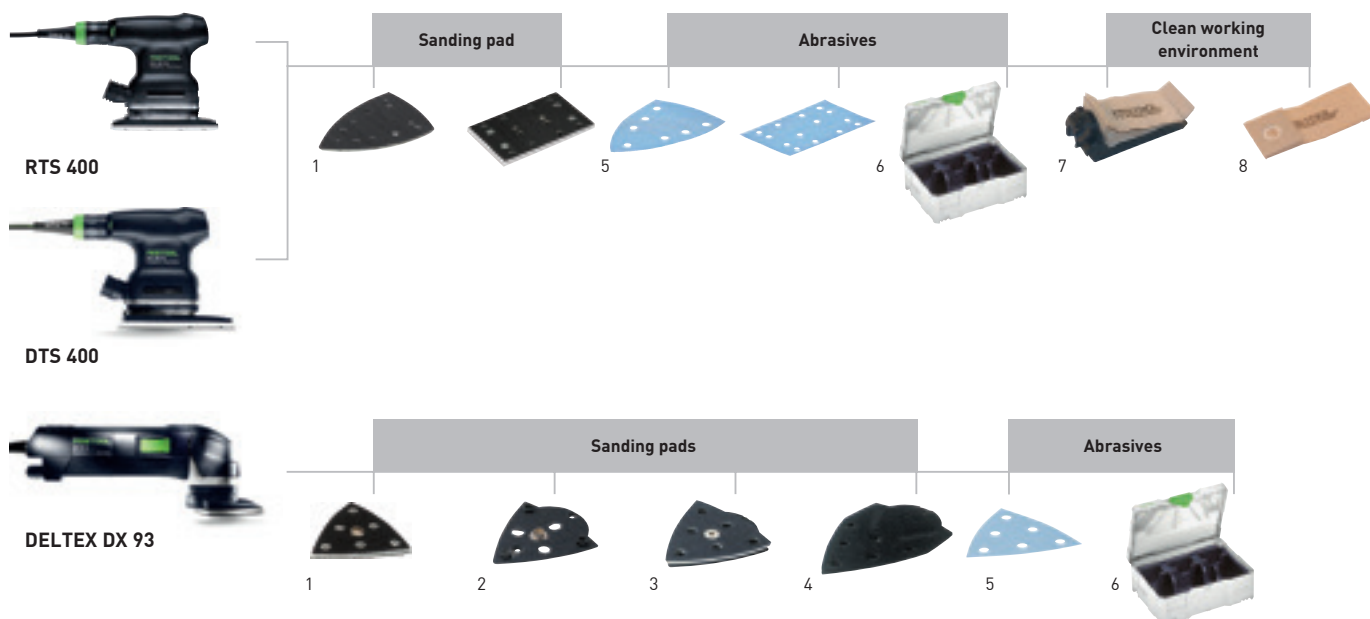

#### Accessories for RUTSCHER RTS 400, delta sander DTS 400, triangle sander DX 93

Denomination	Explanation	RRP in £*	Order no.
<b>1 Sanding pad StickFix SSH-STF-80x130/12</b>	for RTS 400, RS 400, perforated with 12 suction holes, dimensions 80 x 130 mm, in self-service display pack	19,85 23,82	<b>489252</b>
<b>Sanding pad SSH-STF-Delta100x150/7</b>	for DTS 400, DS 400, for sanding even in corners, dimensions 100 x 150 mm, in self-service display pack	22,55 27,06	<b>493723</b>
<b>Sanding pad StickFix, soft SSH-STF-V93/6-W/2</b>	for DX 93 and RO 90 DX, StickFix, with snap stud, qty. in pack 2 piece(s), hardness grade W, in self-service display pack	12,25 14,70	<b>488715</b>
<b>Sanding pad StickFix, hard SSH-STF-V93/6-H/2</b>	for DX 93 and RO 90 DX, StickFix, with snap stud, qty. in pack 2 piece(s), hardness grade H, in self-service display pack	12,25 14,70	<b>488716</b>
<b>2 Plate TP-STF-DX93</b>	for DX 93, component with StickFix coating onto which sanding pad is secured, in self-service display pack	9,95 11,94	<b>488717</b>
<b>3 Conversion kit DX93E TP-STF-V93-W</b>	for DX 93, plate TP-STF-DX93 and sanding pad SSH-STF-V93/6-W, both with snap stud, with snap stud, StickFix, in self-service display pack	14,10 16,92	<b>488899</b>
<b>4 Slat sanding pad SSH-STF-V93L/6</b>	for DX 93, StickFix, qty. in pack 1 piece(s), in self-service display pack	10,95 13,14	<b>488036</b>
<b>5 Abrasives</b>	from page 107		
<b>6 SYSTAINER T-LOC SYS-STF 80x133</b>	with insert for abrasives 80x133 mm, number of compartments 6, systainer size SYS 1 T-LOC	45,05 54,06	<b>497684</b>
<b>SYSTAINER T-LOC SYS-STF Delta 100x150</b>	with insert for abrasives STF Delta 100x150, number of compartments 5, systainer size SYS 1 T-LOC	45,05 54,06	<b>497686</b>
<b>SYSTAINER SYS-STF-D77/D90/93V</b>	with insert for Ø 90 mm abrasives and 93V abrasives, number of compartments 8, systainer size SYS 1 T-LOC	44,55 53,46	<b>497687</b>
<b>7 Turbo filter bag set TFS-RS 400</b>	for RS 400, RTS 400, DS 400, DTS 400, ES 125, ETS 125, for clear view and healthy working environment, filter cartridge, 5 turbofilters, in self-service display pack	18,05 21,66	<b>489129</b>
<b>8 Turbo filter bag TF-RS 400/5</b>	for RS 400, RTS 400, DS 400, DTS 400, ES 125, ETS 125, for insertion in filter cartridge, qty. in pack 5 piece(s), in self-service display pack	7,20 8,64	<b>489128</b>
<b>Turbo filter bag TF-RS 400/25</b>	for RS 400, RTS 400, DS 400, DTS 400, ES 125, ETS 125, for insertion in filter cartridge, qty. in pack 25 piece(s), in a carton	29,80 35,76	<b>489127</b>

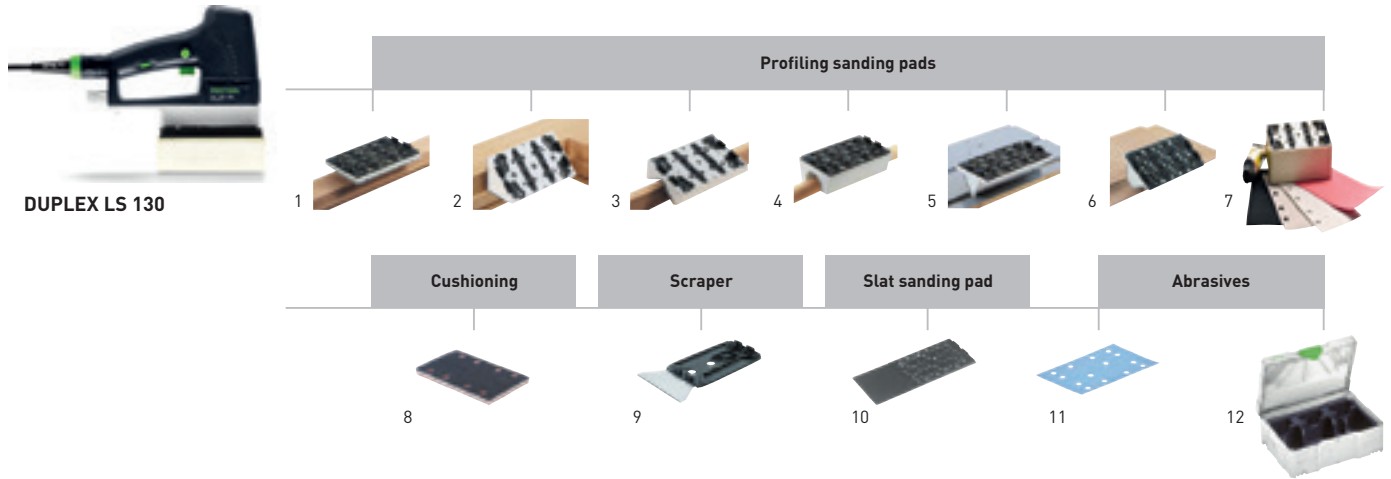

### Accessories for linear sander DUPLEX LS 130

Denomination	Explanation	RRP in £*	Order no.
1 Flat sanding pad SSH-STF-LS130-F	standard design, dimensions 80 x 130 mm, in self-service display pack	23,00 27,60	490161
2 Rebate profile sanding pad SSH-STF-LS130-90 GR	90 degrees, dimensions 80 x 130 mm, in self-service display pack	25,00 30,00	490162
3 Radius profile sanding pad SSH-STF-LS130-R6KV	radius R6 concave, dimensions 80 x 130 mm, in self-service display pack	25,00 30,00	490163
Radius profile sanding pad SSH-STF-LS130-R10KV	radius R10 concave, dimensions 80 x 130 mm, in self-service display pack	25,00 30,00	491197
4 Radius profile sanding pad SSH-STF-LS130-R18KV	radius R18, concave, dimensions 80 x 130 mm, in self-service display pack	25,00 30,00	490164
Radius profile sanding pad SSH-STF-LS130-R25KV	radius R25, concave, dimensions 80 x 130 mm, in self-service display pack	25,00 30,00	490165
5 V-groove profile sanding pad SSH-STF-LS130-V10	10 mm, dimensions 80 x 130 mm, in self-service display pack	25,00 30,00	490166
6 Flute profile sanding pad SSH-STF-LS130-R10KX	radius R10 convex, dimensions 80 x 130 mm, in self-service display pack	25,00 30,00	491198
Flute profile sanding pad SSH-STF-LS130-R25KX	radius R25, convex, dimensions 80 x 130 mm, in self-service display pack	25,00 30,00	490167
7 DIY construction kit SSH-STF-LS130 Kit	kit for creating any type of profiling pad, in self-service display pack	35,85 43,02	490780
8 Interface pad IP-STF-80x133/12-STF LS130/2	damping element between sanding pad and abrasive, dimensions 80 x 133 mm, qty. in pack 2 piece(s), in self-service display pack	10,05 12,06	490160
9 Scraper SSH-LS130-B100	for removing coatings, width 100 mm, in self-service display pack	18,45 22,14	491199
10 Flat sanding pad long SSH-STF-LS130-LL195	for relief grinding of facings, dimensions 80 x 195 mm, in self-service display pack	14,35 17,22	491861
11 Abrasives	from page 107		
12 SYSTAINER T-LOC SYS-STF 80x133	with insert for abrasives 80x133 mm, number of compartments 6, systainer size SYS 1 T-LOC	45,05 54,06	497684

## Surface treatment

### System accessories

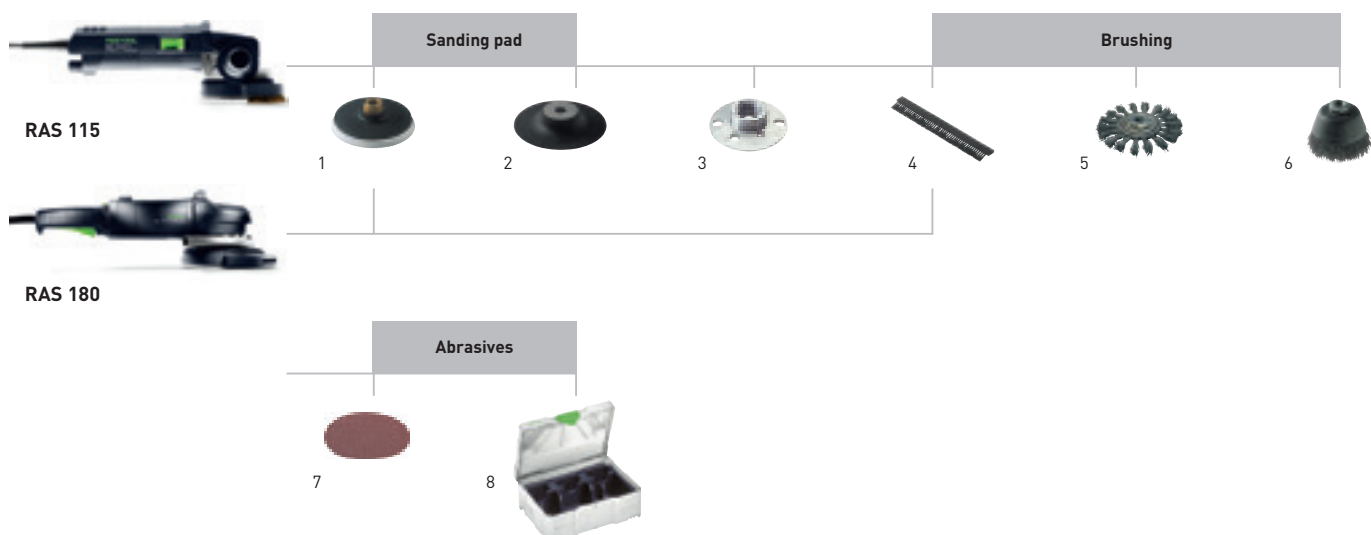

#### Accessories for rotary sander RAS 115

Denomination	Explanation	RRP in £*	Order no.	
1 Sanding pad ST-STF-D115/0-M14 W	for RAS 115, soft version, for universal use on plain and arced surfaces, connecting thread M14, in self-service display pack	17,95 21,54	484173	
	Sanding pad ST-STF-D115/0-M14 H	for RAS 115, hard version, high edge solidity, for plain surfaces and narrow edges, connecting thread M14, in self-service display pack		18,75 22,50
	Sanding pad ST-D115/0-M14/2F	for RAS 115, for fibre discs and Longlife fibre discs Ø 115 mm, clamping nut, connecting thread M14, in self-service display pack		17,95 21,54
2 Flexible sanding pad ST-D115/0-EL	for RAS 115, for fibre discs and Longlife fibre discs Ø 115 mm, without clamping nut, connecting thread M14, in self-service display pack	10,45 12,54	439580	
	3 Clamping nut SM-M14/D115	for RAS 115, RAP 80, for securing Fiberfix sanding discs, in a bag		8,00 9,60
4 Brush insert for RAS AHP-RAS D115/2	for RAS 115, with plastic bristles, qty. in pack 2 piece(s), in a bag	15,75 18,90	484727	
	Brush insert for RAS AHM-RAS D115	for RAS 115, with metal bristles, qty. in pack 1 piece(s), in a bag		15,20 18,24
5 Circular brush RB-D115/M14 RAS 115	for RAS 115, RAP 80, braided, for removal of paint and rust and cleaning surfaces, in self-service display pack	20,70 24,84	485096	
6 Cup brush TB-D80/M14 RAS 115	for RAS 115, RAP 80, for removal of rust and slag to obtain a metallically pure surface, in self-service display pack	13,90 16,68		485097
	Cup brush TB-D65/M14 RAS 115	for RAS 115, RAP 80, braided, for removal of paint and rust and cleaning surfaces, in self-service display pack	16,10 19,32	
7 Abrasives	from page 107			
8 SYSTAINER T-LOC SYS-STF D115	with insert for abrasive Ø 115 mm, number of compartments 5, systainer size SYS 1 T-LOC	45,05 54,06	497683	

#### Accessories for rotary sander RAS 180

Denomination	Explanation	RRP in £*	Order no.
1 Sanding pad ST-STF-D180/0-M14 W	for RAS 180, soft version, for universal use on plain and arced surfaces, connecting thread M14, in self-service display pack	36,75 44,10	485253
	Sanding pad ST-D180/0-M14/2F	for RAS 180, for fibre discs Ø 180 mm, connecting thread M14, in self-service display pack	
4 Brush insert for RAS AHP-RAS D180	for RAS 180, with plastic bristles, qty. in pack 1 piece(s), in a bag	32,95 39,54	485274
7 Abrasives	from page 107		

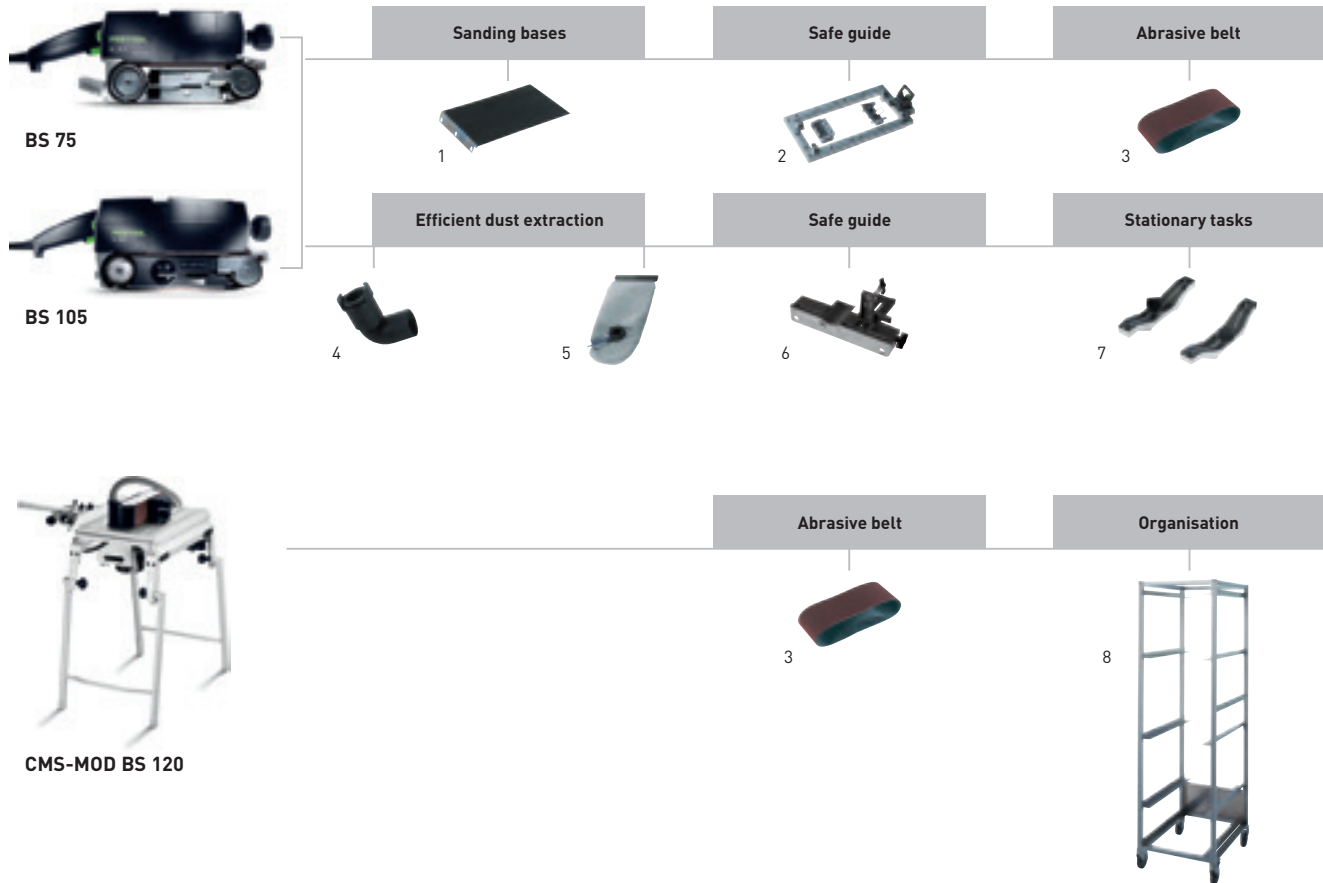

### Accessories for belt sanders BS 75, BS 105

Denomination	Explanation	RRP in £*	Order no.
<b>1 Sanding base SU/GG-BS 75</b>	for BS 75, from fabric/graphite, qty. in pack 2 piece(s), in self-service display pack	11,05 13,26	<b>490823</b>
<b>Sanding base SU/KM-BS 75</b>	for BS 75, made from cork/metal for coarse sanding work, qty. in pack 1 piece(s), in self-service display pack	7,80 9,36	<b>490824</b>
<b>Sanding base SU/GG-BS 105</b>	for BS 105, from fabric/graphite, qty. in pack 2 piece(s), in self-service display pack	12,45 14,94	<b>490825</b>
<b>Sanding base SU/KM-BS 105</b>	for BS 105, made from cork/metal for coarse sanding work, qty. in pack 1 piece(s), in self-service display pack	8,80 10,56	<b>490826</b>
<b>2 Sanding frame FSR-BS 75</b>	for BS 75, quick installation without a tool, mounting element, qty. in pack 1 piece(s), in a carton	133,00 159,60	<b>490827</b>
<b>Sanding frame FSR-BS 105</b>	for BS 105, quick installation without a tool, mounting element, qty. in pack 1 piece(s), in a carton	167,25 200,70	<b>490828</b>
<b>3 Abrasive belt</b>	from page 107		
<b>4 Extraction adapter AA-BS 75/105</b>	for BS 75, BS 105, for connecting suction hose to belt sander, in self-service display pack	12,45 14,94	<b>490818</b>
<b>5 Dust bag AS-BS 75/105</b>	for BS 75, BS 105, in a carton	24,30 29,16	<b>490819</b>
<b>6 Stopper LA-BS 75/105</b>	for BS 75, BS 105, enables flexible sanding of workpieces, in a carton	29,40 35,28	<b>490821</b>
<b>7 Bench unit SE-BS 75/105</b>	for BS 75, BS 105, qty. in pack 2 piece(s), in a carton	22,25 26,70	<b>490820</b>
<b>8 CMS and Basis module tower MT 1600</b>	for CMS, for space-saving storage of the CMS and Basis modules, alternatively, 2 Systainers per shelf can be accommodated, adjustable height, 5 plug-ins, 2 fixed and 2 steering rollers, width 460 mm, depth 600 mm, weight 13 kg, in a carton	316,80 380,16	<b>451975</b>

## Surface treatment

### System accessories

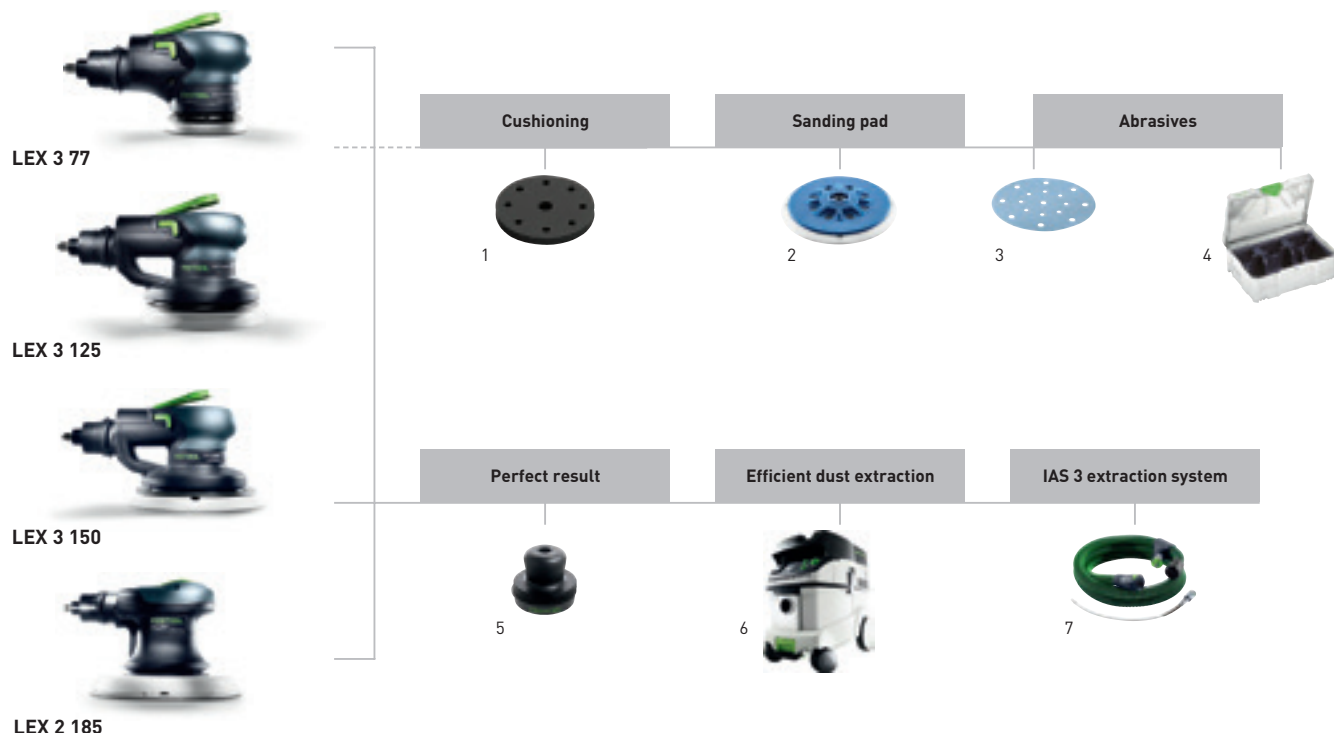

#### Accessories for compressed air eccentric sanders LEX 3 77, LEX 3 125, LEX 3 150, LEX 2 185

Denomination	Explanation	RRP in £*	Order no.
<b>1</b> Interface pad IP-STF-D77/6	for LEX 3 77, as damping element between sanding disc and sanding pad, Height 10 mm, Diameter 77 mm, qty. in pack 2 piece(s), in self-service display pack	14,60 17,52	<b>498818</b>
Interface pad IP-STF-D120/90/8	for ES 125, ETS 125as damping element between sanding disc and sanding pad, for sanding contoured parts and fine-sanding parts with eccentric sander Ø 125 mm, Height 15 mm, Diameter 120 mm, diameter of jet stream holes 90 mm, qty. in pack 1 piece(s), in self-service display pack	8,00 9,60	<b>492271</b>
Interface pad IP-STF D 150/17 MJ-S2x	for eccentric sander with diameter of 150 mm, as damping element between sanding disc and sanding pad, MULTI-JETSTREAM, optimal thickness for sanding work on bodies and similarly shaped components, Diameter 145 mm, Height 5 mm, qty. in pack 2 piece(s), in self-service display pack	15,90 19,08	<b>499257</b>
Interface pad IP-STF D 150/17 MJ	for eccentric sander with diameter of 150 mm, as damping element between sanding disc and sanding pad, MULTI-JETSTREAM, optimal thickness for sanding work on curved components, Height 15 mm, Diameter 145 mm, in self-service display pack	10,15 12,18	<b>496647</b>
<b>2</b> Sanding pad ST-STF-D77/6-M5 W	for LEX 3 77, soft version, for tough and universal use, hardness grade W, Diameter 77 mm, connecting thread M5, qty. in pack 1 piece(s), in self-service display pack	24,50 29,40	<b>498694</b>
Sanding pad ST-STF-LEX 125/90/8-M8 H	for LEX 125, hard version, high edge solidity, for plain surfaces and narrow edges, high temperature durability burr, connecting thread M8, hardness grade H-HT, qty. in pack 1 piece(s), in self-service display pack	39,00 46,80	<b>492284</b>
Sanding pad ST-STF-LEX 125/90/8-M8 W-HT	for LEX 125, soft version, for universal use on plain and arced surfaces, high temperature durability burr, connecting thread M8, hardness grade W-HT, qty. in pack 1 piece(s), in self-service display pack	39,00 46,80	<b>492286</b>
Sanding pad ST-STF-LEX 125/90/8-M8 SW	for LEX 125, ultra-soft version, elastic structure, for heavy roundings and cambers, connecting thread M8, hardness grade SW, qty. in pack 1 piece(s), in self-service display pack	39,00 46,80	<b>492288</b>
Sanding pad ST-STF D150/17FT-M8-SW	for ETS 150, ETS EC 150, LEX 3 150 and WTS 150/7, ultra-soft version, MULTI-JETSTREAM, elastic structure, for heavy roundings and cambers, hardness grade SW, connecting thread M8, qty. in pack 1 piece(s), in self-service display pack	42,70 51,24	<b>498986</b>
Sanding pad ST-STF D150/17FT-M8-W-HT	for ETS 150, ETS EC 150, LEX 3 150 and WTS 150/7, soft version, MULTI-JETSTREAM, high temperature durability burr, high edge solidity, for tough and universal use, hardness grade W-HT, connecting thread M8, qty. in pack 1 piece(s), in self-service display pack	42,70 51,24	<b>498987</b>
Sanding pad ST-STF D150/17FT-M8-H-HT	for ETS 150, ETS EC 150, LEX 3 150 and WTS 150/7, hard version, MULTI-JETSTREAM, high temperature durability burr, high edge solidity, for flat surfaces, hardness grade H-HT, connecting thread M8, qty. in pack 1 piece(s), in self-service display pack	42,70 51,24	<b>498988</b>
Sanding pad ST-STF-D185/16-M8 W	soft version, for universal use on plain and arced surfaces, connecting thread M8, hardness grade W, qty. in pack 1 piece(s), in self-service display pack	46,70 56,04	<b>490514</b>
Sanding pad ST-STF-D185/16-M8 SW	ultra-soft version, elastic structure, for heavy roundings and cambers, connecting thread M8, hardness grade SW, qty. in pack 1 piece(s), in self-service display pack	46,70 56,04	<b>490526</b>
<b>3</b> Abrasives	from page 107		



**Accessories for compressed air eccentric sanders LEX 3 77, LEX 3 125, LEX 3 150, LEX 2 185**

Denomination	Explanation	RRP in €*	Order no.
<b>4 SYSTAINER SYS-STF-D77/D90/93V</b>	with insert for Ø 90 mm abrasives and 93V abrasives, number of compartments 8, systainer size SYS 1 T-LOC	44,55	<b>497687</b>
		53,46	
<b>SYSTAINER T-LOC SYS-STF D125</b>	with insert for abrasives Ø 125 mm, number of compartments 5, systainer size SYS 1 T-LOC	45,05 54,06	<b>497685</b>
<b>SYSTAINER T-LOC SYS-STF D150</b>	with insert for abrasives Ø 150 mm, number of compartments 10, systainer size SYS 3 T-LOC	52,60 63,12	<b>497690</b>
<b>SYSTAINER T-LOC SYS-STF D150 4S</b>	with insert for abrasives Ø 150 mm, for grits P80, P180, P280, P400 and P500 according to the Festool "4-step sanding" system, systainer size SYS 3 T-LOC	56,20 67,44	<b>497821</b>
<b>5 Guide control black powder HB-Set</b>	for visibly checking surfaces to be sanded, hand sanding block, 2 guide control black powder cartridges (each 30 g), in a carton	29,80	<b>495939</b>
		35,76	
<b>Refillable cartridge 2x30 g</b>	refill for the guide control black powder HB set (2 x 30 g), in a carton	13,90 16,68 23,17 / 100 g 27,80 / 100 g	<b>495940</b>
<b>6 CT mobile dust extractors</b>	from page 264		
<b>7 IAS hoses IAS 3</b>	from page 105		
<b>IAS adapter IAS 3-SD</b>	for LEX 3, LEX 2, LRS, for connecting a Festool compressed air sander directly to a compressed air line (without dust extraction), Length 90 mm, in a carton	58,20 69,84	<b>497214</b>
<b>Compressed air hose D 12,4 x 5m</b>	for LEX 3, LEX 2, LRS, IAS 3-SD, the IAS 3-SD adapter is necessary for connection to the machine, Length 5 m, in a carton	49,80 59,76 9,96 / 1 m 11,95 / 1 m	<b>497215</b>
<b>IAS double adapter IAS 3-DA-CT</b>	for LEX 3, LEX 2, LRS, CT extractor (not CT 11/MINI/MIDI), for simultaneously connecting two air tools with IAS 2 and/or IAS 3 adapter to a Festool dust extractor, in a carton	65,70 78,84	<b>497284</b>
<b>Adapter AD-IAS/D 36</b>	for use with D 36 suction nozzles with IAS 2/IAS 3 hoses, note: if IAS 2/IAS 3 hoses are used without this adapter to extract dirt directly, the hoses and air tools may be damaged by dirt deposits in connecting parts, in a bag	40,10 48,12	<b>488418</b>
<b>Adapter IAS-ZA</b>	rubber bushing for connection of IAS 2/IAS 3 air tools via an IAS 2/IAS 3 connection, for central extraction units, boom arms manufactured by Rupes, IVO and Herkules, and Rupes power boxes, exterior Ø 59/75 mm, Inside dia. 49/57 mm, in a carton	46,80 56,16	<b>489222</b>
<b>connecting sleeve IAS 3-B1</b>	for LEX 3, LEX 2, LRS, for connecting an IAS 3 or IAS 3 light hose to an SRM 70/SRM 312 B1 extractor, in self-service display pack	10,40 12,48	<b>499024</b>
<b>Adapter IAS 3-FA</b>	for LEX 3, LEX 2, LRS, for connecting an IAS 3 or IAS 3 light hose to an EAA power box or Herkules exhaust turbine, sleeve diameter 47,5-51,8 mm, in self-service display pack	23,55 28,26	<b>499025</b>
<b>IAS adapter IAS-S-ZA/Hamach</b>	for connection of IAS 2/IAS 3 suction hoses to Hamach/Rupes central suction system, with closing slide, in a carton	112,60 135,12	<b>490603</b>
<b>IAS adapter IAS-S-ZA/Herkules</b>	for connection of IAS 2/IAS 3 suction hoses to Herkules central suction system, with closing slide, in a carton	97,05 116,46	<b>490605</b>
<b>Cleaning and lubricating oil LD 10/50</b>	for LEX, LRS, special oil for compressed air preparation, 50 ml, In plastic bottle	3,00	<b>481713</b>
		3,60	
		6,00 / 100 ml 7,20 / 100 ml	
<b>Cleaning and lubricating oil LD 10/1000</b>	for LEX, LRS, special oil for compressed air preparation, In plastic bottle	17,85	<b>481722</b>
		21,42	

## Surface treatment

### System accessories

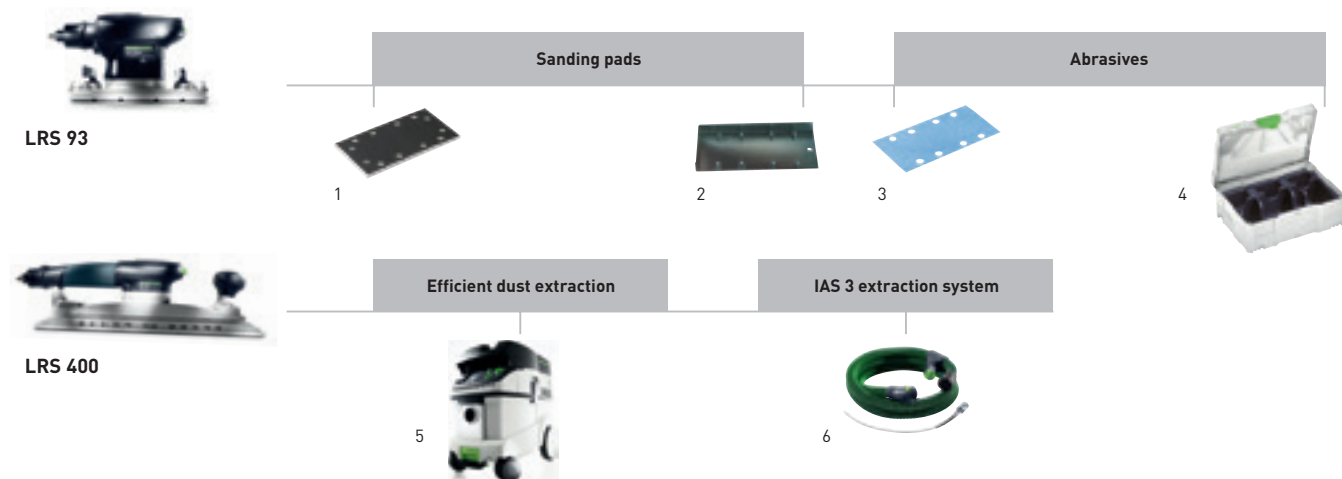

### Accessories for compressed air orbital sanders LRS 93, LRS 400

Denomination	Explanation	RRP in £*	Order no.	
1 Sanding pad StickFix SSH-STF-93x175/8	for RS 300, RS 3, LRS 93, StickFix adhesive layer for quick change of sanding pad, dimensions 93 x 175 mm in self-service display pack	23,65 28,38	483905	
	Sanding pad SSH-93x175/8	for RS 300, RS 3, LRS 93, for abrasives for clamping, dimensions 93 x 175 mm, in self-service display pack	20,50 24,60	489630
	Sanding pad StickFix SSH-STF-V93x266/14	for RS 300, RS 3, LRS 93, pressing iron sanding pad version, dimensions 93 x 266 mm, in self-service display pack	33,75 40,50	486418
Sanding pad SSH-STF-80x400/17	for LRS 400, soft, dimensions 80 x 400 mm, hardness grade W, qty. in pack 1 piece(s), in self-service display pack	51,65 61,98	493140	
	2 Hole punch 8L 93x175	for RS 300, RS 3, LRS 93, for preparing the Festool hole pattern, no. of holes 8, dimensions 93 x 175 mm, in self-service display pack	18,05 21,66	481903
3 Abrasives	from page 107			
4 SYSTAINER T-LOC SYS-STF 93x178/93V	with insert for abrasives 93x178mm, number of compartments 6, systainer size SYS 2 T-LOC	48,90 58,68	497689	
	5 CT mobile dust extractors	from page 264		
6 IAS hoses IAS 3	from page 105			
	IAS adapter IAS 3-SD	for LEX 3, LEX 2, LRS, for connecting a Festool compressed air sander directly to a compressed air line (without dust extraction), Length 90 mm, in a carton	58,20 69,84	497214
	Compressed air hose D 12,4 x 5m	for LEX 3, LEX 2, LRS, IAS 3-SD, the IAS 3-SD adapter is necessary for connection to the machine, Length 5 m, in a carton	49,80 59,76 9,96 / 1 m 11,95 / 1 m	497215
IAS double adapter IAS 3-DA-CT	for LEX 3, LEX 2, LRS, CT extractor (not CT 11/MINI/MIDI), for simultaneously connecting two air tools with IAS 2 and/or IAS 3 adapter to a Festool dust extractor, in a carton	65,70 78,84	497284	
Adapter AD-IAS/D 36	for use with D 36 suction nozzles with IAS 2/IAS 3 hoses, note: if IAS 2/IAS 3 hoses are used without this adapter to extract dirt directly, the hoses and air tools may be damaged by dirt deposits in connecting parts, in a bag	40,10 48,12	488418	
Adapter IAS-ZA	rubber bushing for connection of IAS 2/IAS 3 air tools via an IAS 2/IAS 3 connection, for central extraction units, boom arms manufactured by Rupes, IVO and Herkules, and Rupes power boxes, exterior Ø 59/75 mm, Inside dia. 49/57 mm, in a carton	46,80 56,16	489222	
connecting sleeve IAS 3-B1	for LEX 3, LEX 2, LRS, for connecting an IAS 3 or IAS 3 light hose to an SRM 70/SRM 312 B1 extractor, in self-service display pack	10,40 12,48	499024	
Adapter IAS 3-FA	for LEX 3, LEX 2, LRS, for connecting an IAS 3 or IAS 3 light hose to an EAA power box or Herkules exhaust turbine, sleeve diameter 47,5-51,8 mm, in self-service display pack	23,55 28,26	499025	
IAS adapter IAS-S-ZA/Hamach	for connection of IAS 2/IAS 3 suction hoses to Hamach/Rupes central suction system, with closing slide, in a carton	112,60 135,12	490603	
IAS adapter IAS-S-ZA/Herkules	for connection of IAS 2/IAS 3 suction hoses to Herkules central suction system, with closing slide, in a carton	97,05 116,46	490605	
Cleaning and lubricating oil LD 10/50	for LEX, LRS, special oil for compressed air preparation, 50 ml, In plastic bottle	3,00 3,60	481713	
	Cleaning and lubricating oil LD 10/1000	for LEX, LRS, special oil for compressed air preparation, In plastic bottle	6,00 / 100 ml 7,20 / 100 ml	
Cleaning and lubricating oil LD 10/1000	for LEX, LRS, special oil for compressed air preparation, In plastic bottle	17,85 21,42	481722	

IAS 3 hoses

Suction hose antistatic version



**IAS hose**

for LEX 3, LEX 2, LRS, antistatic, in accordance with DIN IEC 312, bleeder resistor (DIN IEC 312) < 1 MΩ/m, temperature-resistant up to + 70 °C, hose Ø 44 mm, in a carton

for connecting a Festool compressed air sander to a Festool mobile dust extractor or energy box, Length 3,5 m

Type	RRP in £*	Order no.
IAS 3-3500 AS	204,45 245,34 58,41 / 1 m 70,09 / 1 m	<b>497208</b>
IAS 3-5000 AS	241,95 290,34 48,39 / 1 m 58,07 / 1 m	<b>497209</b>
IAS 3-7000 AS	312,20 374,64 44,60 / 1 m 53,52 / 1 m	<b>497210</b>
IAS 3-10000 AS	481,85 578,22 48,19 / 1 m 57,83 / 1 m	<b>497211</b>
IAS 3-15000 AS	648,75 778,50 43,25 / 1 m 51,90 / 1 m	<b>497212</b>



**IAS hose**

for LEX 3, LEX 2, LRS, antistatic, in accordance with DIN IEC 312, bleeder resistor (DIN IEC 312) < 1 MΩ/m, temperature-resistant up to + 70 °C, hose Ø 37 mm, in a carton

for connecting a Festool compressed air sander to a Festool mobile dust extractor or energy box, Length 3,5 m

IAS 3 light 3500 AS	180,10 216,12 51,46 / 1 m 61,75 / 1 m	<b>497478</b>
IAS 3 light 5000 AS	210,95 253,14 42,19 / 1 m 50,63 / 1 m	<b>497213</b>
IAS 3 light 7000 AS	256,90 308,28 36,70 / 1 m 44,04 / 1 m	<b>497479</b>
IAS 3 light 10000 AS	397,50 477,00 39,75 / 1 m 47,70 / 1 m	<b>497480</b>
IAS 3 light 15000 AS	558,75 670,50 37,25 / 1 m 44,70 / 1 m	<b>497554</b>

## Surface treatment

### System accessories



#### Accessories for manual sanding

Denomination	Explanation	RRP in £*	Order no.
1 Sanding block HSK-A 80x130	compatible abrasive 80 x 133 mm, adapter for Festool hose, bypass adapter, exterior Ø hose interface without/with adapter 21,5/27 mm, weight 0,19 kg, in a carton	48,65 58,38	496962
2 Sanding block HSK-A 115x226	compatible abrasive 115 x 228 mm, adapter for Festool hose, bypass adapter, exterior Ø hose interface without/with adapter 21,5/27 mm, weight 0,28 kg, in a carton	92,10 110,52	496963
3 Sanding block HSK-A 80x400	compatible abrasive 80 x 400 mm, adapter for Festool hose, bypass adapter, exterior Ø hose interface without/with adapter 21,5/27 mm, weight 0,52 kg, in a carton	101,85 122,22	496964
4 Sanding block HSK-A 80x200	compatible abrasive 80 x 400 mm (halved), adapter for Festool hose, bypass adapter, exterior Ø hose interface without/with adapter 21,5/27 mm, weight 0,2 kg, in a carton	72,75 87,30	496965
Sanding block HSK-A-Set	compatible abrasive 80 x 133 mm, 115 x 228 mm, 80 x 400 mm, adapter for Festool hose, bypass adapter, HSK-A 80x130, HSK-A 80x200, HSK-A 80x400, HSK-A 115x226, in a carton	251,90 302,28	497101
5 Hand-sanding block HSK-STF-46x178	for supporting StickFix, abrasive sheets 46 x 178 mm, in self-service display pack	9,35 11,22	583129
6 Sanding block HSK-D 150 W	for attaching StickFix Ø 150 mm sanding discs, soft, in self-service display pack	17,00 20,40	495965
Sanding block HSK-D 150 H	for attaching StickFix Ø 150 mm sanding discs, hard, in self-service display pack	17,95 21,54	495966
7 Sanding block HSK80x133 H	for attaching StickFix 80 x 133 mm abrasive sheets, hard, in self-service display pack	17,95 21,54	495967
8 Abrasives	from page 123		

#### Accessories for RUSTOFIX BMS 180

Denomination	Explanation	RRP in £*	Order no.
1 Rustilon brushes LD 85	for BMS 180, for texturing, with standard steel wire, steel core, exterior Ø 150 mm, width 85 mm, Bore hole Ø 50 mm, in a carton	135,00 162,00	411549
2 Rustilon brushes KB 80	for BMS 180, for intermediate sanding, plastic bristles with embedded K80 grit, die-cast plastic core, exterior Ø 150 mm, width 85 mm, Bore hole Ø 16/30 mm, in a carton	123,80 148,56	411969
3 Rustilon brushes BG 85	for BMS 180, for smoothing, with sisal bristles, steel core, exterior Ø 150 mm, width 80 mm, Bore hole Ø 50 mm, in a carton	100,45 120,54	411887

**Impressive not just on paper, but also in the workshop.**

You can rely on Festool for the right abrasive for every tool and every application. A single rule applies: the more compatible the abrasive and sanding pad are with the tool, the more efficient and economical the working results will be.

**No disc disintegration.**

A combination of extremely tear-resistant and flexible synthetic resin bonds the two layers of abrasive grit. This prevents the discs from disintegrating prematurely.

**Wear-resistant grit.**

The abrasive grain is very hard but also durable. Each grain therefore retains its shape even under the toughest conditions, guaranteeing outstanding material removal.

**Extended useful life.**

The special combination of abrasive grain, bonding and surface geometry delays clogging of the abrasive. Festool Platin 2, Titan 2 and Granat abrasives have a dust-repellent coating for an even longer useful life.

**Even sanding.**

The uniform grains ensure a consistent depth of roughness across the abrasive. Resulting in a clean sanding finish, less reworking and, therefore, a considerable time-saving.

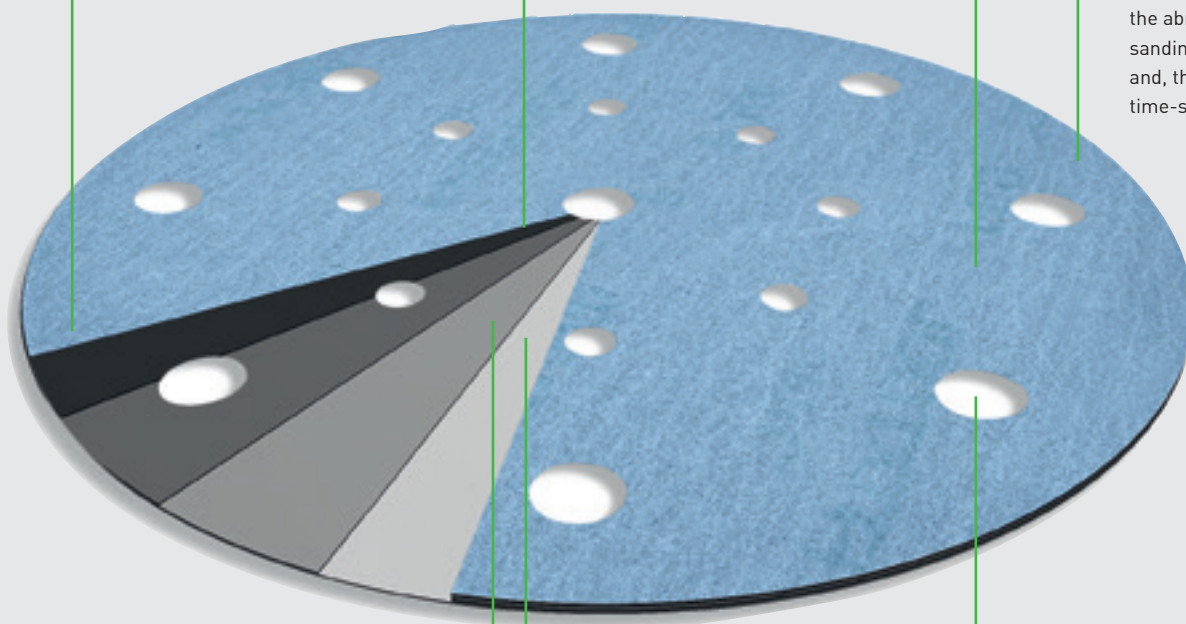
**Flexible and stable backing material.**

Festool uses flexible backing material made from paper, cotton fabric or synthetic fibres, depending on requirements. The backing adheres extremely well to both the paper and the bonding. The material remains extremely flexible and transitions are sanded smooth.

**Quick changes with the StickFix system.**

Festool abrasives are changed without gluing or clamping: just pull one off and attach the next one. The Velcro system is reliable, does not slip and the discs are easy to peel off.

**Improved dust extraction.**

Intensive dust extraction by the patented Jetstream and MULTI-JETSTREAM principle increases the service life of the sanding discs. See page 108 for details of the MULTI-JETSTREAM system.

# Surface treatment

## Abrasives

Achieving the perfect surface finish depends on the smallest of details. All Festool abrasives and sanding pads are adapted perfectly to the relevant sander as

well as the overall system. Economical working and faultless results guaranteed in all sanding applications.

### Abrasives

#### Granat

P40-3000

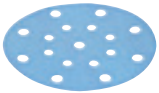

#### Universal for coarse to fine sanding

Sanding:

- Paint systems compliant with VOC regulations
- Water-dilutable clear coats
- Hard clear coats, undercoats such as GRP
- Also suitable for conventional clear coats, filler, paints

#### Rubin 2

P40-220

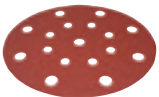

#### Perfect for processing wood

Sanding:

- Hardwood
- Softwood
- Wood composites
- Tropical wood

#### Brilliant 2

P40-400

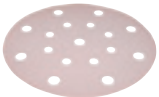

#### Universal for paints and clear coats.

Sanding:

- Acrylic and nitro-cellulose paint, priming varnish, DD lacquer
- Repair compound, fine and polyester filler
- Undercoats, fillers, protective paint, primers
- Preparation prior to priming wood (oil, wood stains)

#### Titan 2

P40-3000



#### For repair compounds, fillers and clear coats

Sanding:

- Synthetic resin, nitro-cellulose, thick-layer and combination fillers, priming filler
- Primers, reaction primers
- 2-component materials
- Water-dilutable clear coats
- Light sanding of top coat / matt sanding prior to repainting
- Ceramic paints

#### Platin 2

S400-4000



#### For perfect preparation for polishing

Finishing/matting:

- High-gloss paints in preparation for polishing
- Water-dilutable clear coats
- Mineral materials, acrylic glass
- Plastics

#### Diamant

500-1000



#### For preparing coloured, painted coatings

Finishing the hardest surfaces:

- Sanding panel material with a melamine resin coating

#### Saphir

P24-80

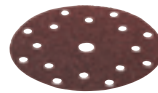

#### For efficient removal of wood and clear coats.

Coarse sanding:

- Hard subsurfaces, coatings, old clear coats
- Worn steps, roughly sawn wooden parts
- Deburring or rust removal
- Fibre-reinforced plastics

#### Vlies

A80-5800



#### For light sanding, cleaning, oiling, waxing

Matting/light sanding of paints and clear coats:

- Lightly sanding old coats of paint before repainting
- Polishing metal
- Cleaning wood materials
- Oiling and waxing natural wood

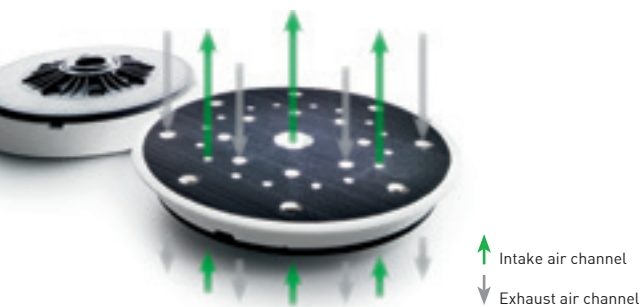

↑ Intake air channel

↓ Exhaust air channel

### With active dust conveying system – the patented MULTI-JETSTREAM principle\*

The patented MULTI-JETSTREAM sanding system is a unique system that operates with intake air and exhaust air to generate an air flow that actively transports the sanding dust to the nearest extraction channel. The result: almost 100% dust extraction, a constant removal rate and an excellent surface quality.

#### Active dust conveying concept

The dust is transported through one large and sixteen small intake air channels towards the exhaust air channels on the sanding pad. Result: the MULTI-JETSTREAM sanding pad is free of dust in one second

#### Dust-free, 6x faster

Rapid dust extraction ensures that the fastener and abrasive remain free of dust for longer periods. The abrasive remains effective and the useful life increases.



#### 10 °C cooler fastener

The supply of cool intake air to the fastener, abrasive and work surface prevents blockages (clogging).

LEX 3 77

RO 90 DX

02

	Grit	Qty. in pack	RRP in £*	Order no.	Grit	Qty. in pack	RRP in £*	Order no.	
<b>Ø 77 mm</b>									
<b>Granat</b> 	P80	50	19,65 23,58	497405	P280	50	19,65 23,58	497410	
	P120	50	19,65 23,58	497406	P320	50	19,65 23,58	497411	
	P150	50	19,65 23,58	497407	P400	50	19,65 23,58	497412	
	P180	50	19,65 23,58	497408	P500	50	19,65 23,58	497413	
	P240	50	19,65 23,58	497409					
	P800	50	32,25 38,70	498929	P1200	50	32,25 38,70	498931	
	P1000	50	32,25 38,70	498930	P1500	50	30,45 36,54	498932	
	<b>Titan 2</b>								
		P3000	50	30,80 36,96	495954				
	<b>Platin 2</b>								
	S400	15	25,05 30,06	497425	S2000	15	24,20 29,04	492378	
	S500	15	25,05 30,06	497426	S4000	15	24,20 29,04	492379	
	S1000	15	25,05 30,06	497427					
<b>Diamant</b>									
	500	4	30,35 36,42	496520	1000	4	30,35 36,42	496521	
<b>Ø 90 mm</b>									
<b>Granat</b> 	P40	50	22,10 26,52	497363	P220	100	33,15 39,78	497370	
	P60	50	20,40 24,48	497364	P240	100	33,15 39,78	497371	
	P80	50	19,45 23,34	497365	P280	100	33,15 39,78	497850	
	P100	100	33,15 39,78	497366	P320	100	33,15 39,78	497372	
	P120	100	33,15 39,78	497367	P400	100	33,15 39,78	497373	
	P150	100	33,15 39,78	497368	P500	100	33,15 39,78	498326	
	P180	100	33,15 39,78	497369					
	P800	50	33,15 39,78	498327	P1200	50	33,15 39,78	498329	
	P1000	50	33,15 39,78	498328	P1500	50	33,15 39,78	498330	
	<b>Rubin 2</b>								
		P40	50	19,10 22,92	499077	P120	50	19,10 22,92	499081
		P60	50	19,10 22,92	499078	P150	50	19,10 22,92	499082
		P80	50	19,10 22,92	499079	P180	50	19,10 22,92	499083
		P100	50	19,10 22,92	499080	P220	50	19,10 22,92	499084

# Surface treatment

## Abrasives

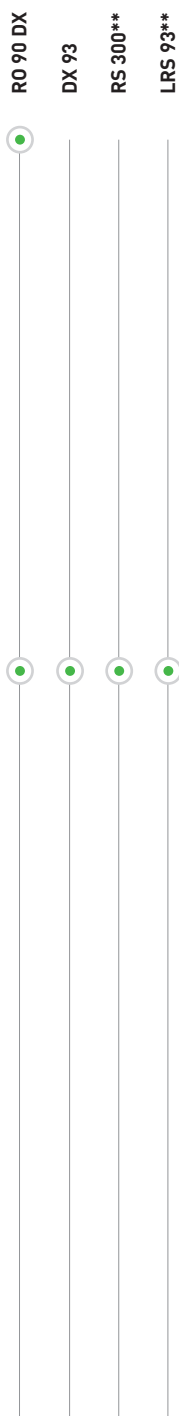

	Grit	Qty. in pack	RRP in €*	Order no.	Grit	Qty. in pack	RRP in €*	Order no.
<b>Ø 90 mm</b>								
<b>Brilliant 2</b>	P40	50	22,45 26,94	497379	P180	100	32,15 38,58	497385
	P60	50	20,60 24,72	497380	P220	100	32,15 38,58	497386
	P80	50	18,55 22,26	497381	P240	100	32,15 38,58	497387
	P100	100	32,15 38,58	497382	P320	100	32,15 38,58	497388
	P120	100	32,15 38,58	497383	P400	100	32,15 38,58	497389
	P150	100	32,15 38,58	497384				
<b>Platin 2</b>	S500	15	27,75 33,30	498322	S2000	15	27,75 33,30	498324
	S1000	15	27,75 33,30	498323	S4000	15	27,75 33,30	498325
<b>93V</b>								
<b>Granat</b>	P40	50	19,45 23,34	497390	P180	100	27,75 33,30	497396
	P60	50	17,55 21,06	497391	P220	100	27,75 33,30	497397
	P80	50	16,70 20,04	497392	P240	100	27,75 33,30	497398
	P100	100	27,75 33,30	497393	P280	100	28,65 34,38	499644
	P120	100	27,75 33,30	497394	P320	100	27,75 33,30	497399
	P150	100	27,75 33,30	497395	P400	100	27,75 33,30	497400
<b>Rubin 2</b>	P40	10	3,50 4,20	499169	P40	50	19,00 22,80	499161
	P60	10	3,50 4,20	499170	P60	50	19,00 22,80	499162
	P80	10	3,10 3,72	499171	P80	50	16,35 19,62	499163
	P100	10	2,70 3,24	499172	P100	50	14,85 17,82	499164
	P120	10	2,70 3,24	499173	P120	50	14,85 17,82	499165
	P150	10	2,70 3,24	499174	P150	50	14,85 17,82	499166
	P180	10	2,70 3,24	499175	P180	50	14,85 17,82	499167
	P220	10	2,70 3,24	499176	P220	50	14,85 17,82	499168



RO 90 DX  
DX 93  
RS 300\*\*  
LRS 93\*\*  
RAS 115

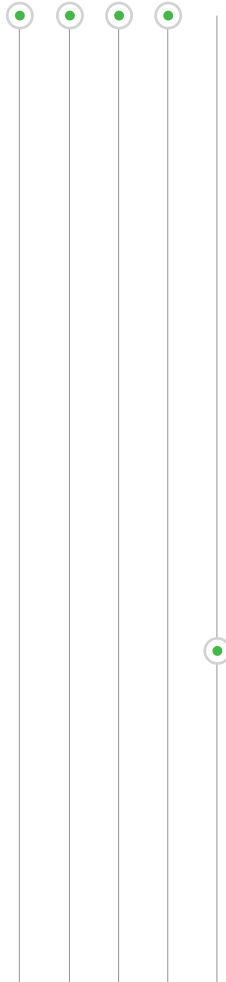

93V

Brilliant 2

Grit	Qty. in pack	RRP in £*	Order no.	Grit	Qty. in pack	RRP in £*	Order no.
P40	10	5,45 6,54	492879	P100	100	26,40 31,68	492886
P60	10	5,45 6,54	496011	P120	100	26,40 31,68	492887
P80	10	4,70 5,64	492880	P150	100	26,40 31,68	492888
P120	10	4,45 5,34	492881	P180	100	26,40 31,68	492889
P180	10	4,45 5,34	492882	P220	100	26,40 31,68	492890
P40	50	17,40 20,88	492883	P240	100	26,40 31,68	492891
P60	50	15,85 19,02	492884	P320	100	26,40 31,68	492892
P80	50	14,80 17,76	492885	P400	100	26,40 31,68	492893
<b>Saphir</b>				P24	25	14,45 17,34	487515
				P36	25	14,45 17,34	498297
				P50	25	12,80 15,36	498298
				P80	25	12,80 15,36	487518

Ø 115 mm

Rubin 2



P40	50	34,35 41,22	499085	P120	50	26,95 32,34	499089
P60	50	31,45 37,74	499086	P150	50	26,95 32,34	499090
P80	50	28,20 33,84	499087	P180	50	26,95 32,34	499091
P100	50	26,95 32,34	499088	P220	50	26,95 32,34	499092
<b>Saphir</b>				P24	25	34,95 41,94	484151
				P36	25	34,95 41,94	484152
				P50	25	29,80 35,76	485245
				P80	25	29,80 35,76	485246

\* Recommended retail price of manufacturer. Dealer prices may vary.  
Excl. VAT. Incl. VAT.

\*\* When using the iron-shaped sanding pad.

# Surface treatment

## Abrasives

RO 125  
ETS 125  
LEX 3 125



### Ø 125 mm

#### Granat



#### Rubin 2

#### Brilliant 2

Grit	Qty. in pack	RRP in €*	Order no.	Grit	Qty. in pack	RRP in €*	Order no.
P40	10	9,20 11,04	497145	P120	100	53,45 64,14	497169
P60	10	9,20 11,04	497146	P150	100	53,45 64,14	497170
P80	10	9,20 11,04	497147	P180	100	53,45 64,14	497171
P120	10	9,20 11,04	497148	P220	100	53,45 64,14	497172
P180	10	9,20 11,04	497149	P240	100	53,45 64,14	497173
P320	10	9,20 11,04	497150	P280	100	53,45 64,14	497174
P40	50	36,85 44,22	497165	P320	100	53,45 64,14	497175
P60	50	34,10 40,92	497166	P360	100	53,45 64,14	497176
P80	50	32,30 38,76	497167	P400	100	53,45 64,14	497177
P100	100	53,45 64,14	497168	P500	100	53,45 64,14	497178
P800	50	53,45 64,14	497179	P1200	50	53,45 64,14	497181
P1000	50	53,45 64,14	497180	P1500	50	53,45 64,14	497182
P40	10	10,60 12,72	499101	P40	50	38,55 46,26	499093
P60	10	10,60 12,72	499102	P60	50	38,55 46,26	499094
P80	10	9,05 10,86	499103	P80	50	32,80 39,36	499095
P100	10	8,40 10,08	499104	P100	50	30,10 36,12	499096
P120	10	8,40 10,08	499105	P120	50	30,10 36,12	499097
P150	10	8,40 10,08	499106	P150	50	30,10 36,12	499098
P180	10	8,40 10,08	499107	P180	50	30,10 36,12	499099
P220	10	8,40 10,08	499108	P220	50	30,10 36,12	499100
P40	10	9,55 11,46	495989	P80	50	28,80 34,56	492945
P60	10	8,60 10,32	495990	P100	100	52,20 62,64	492946
P80	10	8,60 10,32	495991	P120	100	52,20 62,64	492947
P120	10	8,00 9,60	495992	P150	100	52,20 62,64	492948
P180	10	8,00 9,60	495993	P180	100	52,20 62,64	492949
P320	10	8,00 9,60	495994	P220	100	52,20 62,64	492950
P40	50	34,10 40,92	493657	P320	100	52,20 62,64	492951
P60	50	30,60 36,72	492944	P400	100	52,20 62,64	492952

RO 125  
ETS 125  
LEX 3 125



02

Ø 125 mm							
Grit	Qty. in pack	RRP in £*	Order no.	Grit	Qty. in pack	RRP in £*	Order no.
<b>Titan 2</b>							
P80	50	27,75 33,30	492966	P320	100	48,90 58,68	492972
P120	100	48,90 58,68	492967	P360	100	48,90 58,68	492973
P150	100	48,90 58,68	492968	P400	100	48,90 58,68	492974
P180	100	48,90 58,68	492969	P500	100	48,15 57,78	494839
P220	100	48,90 58,68	492970	P800	100	56,65 67,98	495045
P240	100	48,90 58,68	492971				
P1200	100	56,65 67,98	492363	P3000	100	61,70 74,04	492365
P1500	100	56,65 67,98	492364				
<b>Platin 2</b>							
S400	15	31,00 37,20	492373	S2000	15	32,00 38,40	492376
S500	15	31,00 37,20	492374	S4000	15	32,00 38,40	492377
S1000	15	31,00 37,20	492375				
<b>Diamant</b>							
500	2	20,60 24,72	496516	1000	2	20,60 24,72	496517
<b>Saphir</b>							
P24	25	30,60 36,72	493124	P50	25	26,10 31,32	493126
P36	25	30,60 36,72	493125	P80	25	26,10 31,32	493127
<b>Vlies</b>							
A100	5	11,80 14,16	488107	A280	5	11,80 14,16	488108
green	10	21,80 26,16	496510	white	10	21,80 26,16	496511

\* Recommended retail price of manufacturer. Dealer prices may vary.  
Excl. VAT. Incl. VAT.

# Surface treatment

## Abrasives

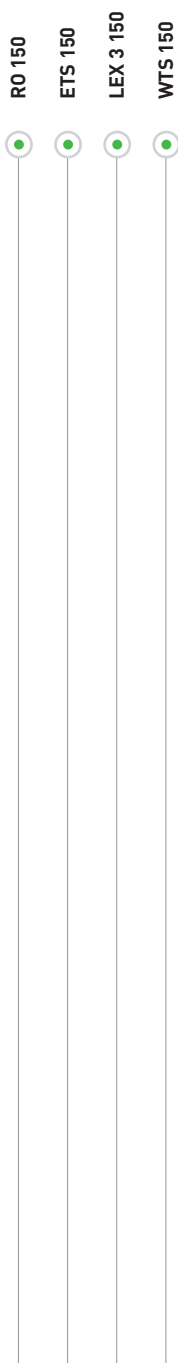

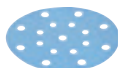
	Grit	Qty. in pack	RRP in €*	Order no.	Grit	Qty. in pack	RRP in €*	Order no.
<b>Ø 150 mm</b>								
<b>Granat</b>	P40	10	10,20 12,24	497151	P120	100	58,95 70,74	496979
	P60	10	10,20 12,24	497152	P150	100	58,95 70,74	496980
	P80	10	10,20 12,24	497153	P180	100	58,95 70,74	496981
	P120	10	10,20 12,24	497154	P220	100	58,95 70,74	496982
	P180	10	10,20 12,24	497155	P240	100	58,95 70,74	496983
	P320	10	10,20 12,24	497156	P280	100	58,95 70,74	496984
	P40	50	40,55 48,66	496975	P320	100	58,95 70,74	496985
	P60	50	36,85 44,22	496976	P360	100	58,95 70,74	496986
	P80	50	36,00 43,20	496977	P400	100	58,95 70,74	496987
	P100	100	58,95 70,74	496978	P500	100	58,95 70,74	496988
	P800	50	58,85 70,62	496989	P1200	50	58,85 70,62	496991
	P1000	50	58,85 70,62	496990	P1500	50	58,85 70,62	496992
<b>Granat soft</b>	P280	20	23,30 27,96	500609	P500	20	23,30 27,96	500612
	P320	20	23,30 27,96	500610	P800	20	45,90 55,08	500613
	P400	20	23,30 27,96	500611				
<b>Rubin 2</b>	P40	10	11,05 13,26	499109	P40	50	43,80 52,56	499117
	P60	10	11,05 13,26	499110	P60	50	39,80 47,76	499118
	P80	10	9,55 11,46	499111	P80	50	34,45 41,34	499119
	P100	10	9,55 11,46	499112	P100	50	31,45 37,74	499120
	P120	10	9,55 11,46	499113	P120	50	31,45 37,74	499121
	P150	10	9,55 11,46	499114	P150	50	31,45 37,74	499122
	P180	10	9,55 11,46	499115	P180	50	31,45 37,74	499123
	P220	10	9,55 11,46	499116	P220	50	31,45 37,74	499124

RO 150  
ETS 150  
LEX 3 150  
WTS 150

02



	Grit	Qty. in pack	RRP in £*	Order no.	Grit	Qty. in pack	RRP in £*	Order no.
<b>Ø 150 mm</b>								
<b>Brilliant 2</b>	P40	10	9,95 11,94	496579	P100	100	55,30 66,36	496588
	P60	10	8,50 10,20	496580	P120	100	55,30 66,36	496589
	P80	10	8,50 10,20	496581	P150	100	55,30 66,36	496590
	P120	10	8,50 10,20	496582	P180	100	55,30 66,36	496591
	P180	10	8,50 10,20	496583	P220	100	55,30 66,36	496592
	P320	10	8,50 10,20	496584	P240	100	55,30 66,36	496593
	P40	50	35,65 42,78	496585	P320	100	55,30 66,36	496594
	P60	50	32,15 38,58	496586	P400	100	55,30 66,36	496595
	P80	50	30,50 36,60	496587				
<b>Titan 2</b>	P40	50	28,35 34,02	496629	P240	100	51,55 61,86	496637
	P60	50	28,35 34,02	496630	P280	100	51,55 61,86	496638
	P80	50	28,35 34,02	496631	P320	100	51,55 61,86	496639
	P100	100	51,55 61,86	496632	P360	100	51,55 61,86	496640
	P120	100	51,55 61,86	496633	P400	100	51,55 61,86	496641
	P150	100	51,55 61,86	496634	P500	100	51,55 61,86	496642
	P180	100	51,55 61,86	496635	P800	100	59,65 71,58	496643
	P220	100	51,55 61,86	496636				
	P1200	100	59,65 71,58	492348	P3000	100	59,65 71,58	496368
	P1500	100	59,65 71,58	492349				
<b>Platin 2</b>	S400	15	36,75 44,10	492368	S2000	15	37,40 44,88	492371
	S500	15	36,75 44,10	492369	S4000	15	37,40 44,88	492372
	S1000	15	36,75 44,10	492370				
<b>Diamant</b>	500	2	25,40 30,48	496512	1000	2	25,40 30,48	496513
<b>Saphir</b>	P24	5	10,95 13,14	496620	P24	25	43,70 52,44	496624
	P36	5	10,95 13,14	496621	P36	25	43,70 52,44	496625
	P50	5	10,95 13,14	496622	P50	25	37,25 44,70	496626
	P80	5	10,95 13,14	496623	P80	25	37,25 44,70	496627
<b>Vlies</b>	A100	5	12,45 14,94	482778	S800	5	12,45 14,94	482780
	A280	5	12,45 14,94	482779				
	green	10	26,75 32,10	496508	white	10	26,75 32,10	496509

# Surface treatment

## Abrasives

RAS 180  
LEX 2 185/7  
LHS 225



	Grit	Qty. in pack	RRP in €*	Order no.	Grit	Qty. in pack	RRP in €*	Order no.
<b>Ø 180 mm</b>								
<b>Rubin 2</b> 	P40	50	66,80 80,16	499125	P120	50	55,95 67,14	499129
	P60	50	66,80 80,16	499126	P150	50	55,95 67,14	499130
	P80	50	58,20 69,84	499127	P180	50	55,95 67,14	499131
	P100	50	55,95 67,14	499128	P220	50	55,95 67,14	499132
<b>Saphir</b>	P24	25	73,80 88,56	485239	P50	25	62,85 75,42	485241
	P36	25	73,80 88,56	485240	P80	25	62,85 75,42	485242
<b>Ø 185 mm</b>								
<b>Granat</b> 	P40	50	45,75 54,90	497183	P150	100	73,55 88,26	497187
	P60	50	44,15 52,98	497184	P180	100	73,55 88,26	497188
	P80	50	44,15 52,98	497185	P240	100	73,55 88,26	497189
	P100	100	75,85 91,02	499629	P320	100	73,55 88,26	497190
	P120	100	73,55 88,26	497186	P400	100	73,55 88,26	497191
<b>Titan 2</b>	P80	50	33,65 40,38	492744	P180	100	66,55 79,86	492748
	P120	100	66,55 79,86	492746	P240	100	66,55 79,86	492749
	P150	100	66,55 79,86	492747	P320	100	66,55 79,86	492750
<b>Ø 225 mm</b>								
<b>Granat</b> 	P40	25	41,20 49,44	499634	P150	25	34,65 41,58	499639
	P60	25	34,65 41,58	499635	P180	25	34,65 41,58	499640
	P80	25	34,65 41,58	499636	P220	25	34,65 41,58	499641
	P100	25	34,65 41,58	499637	P240	25	34,65 41,58	499642
	P120	25	34,65 41,58	499638	P320	25	34,65 41,58	499643

LHS 225  
RTS 400  
LS 130  
HSK-A 80x130

Ø 225 mm								
<b>Brilliant 2</b>								
Grit	Qty. in pack	RRP in €*	Order no.	Grit	Qty. in pack	RRP in €*	Order no.	
P16	25	61,70 74,04	495925	P120	25	28,60 34,32	495931	
P24	25	54,65 65,58	495926	P150	25	28,60 34,32	495066	
P40	25	34,20 41,04	495927	P180	25	28,60 34,32	495067	
P60	25	28,50 34,20	495928	P220	25	28,60 34,32	495068	
P80	25	26,60 31,92	495929	P240	25	28,60 34,32	495932	
P100	25	28,60 34,32	495930	P320	25	28,60 34,32	495933	
<b>Saphir</b>								
P24	25	90,35 108,42	495174	P36	25	90,35 108,42	495175	

80 x 133 mm								
<b>Granat</b>								
Grit	Qty. in pack	RRP in €*	Order no.	Grit	Qty. in pack	RRP in €*	Order no.	
P40	10	8,00 9,60	497127	P120	100	33,15 39,78	497120	
P80	10	8,00 9,60	497128	P150	100	33,15 39,78	497121	
P120	10	8,00 9,60	497129	P180	100	33,15 39,78	497122	
P180	10	8,00 9,60	497130	P220	100	33,15 39,78	497123	
P40	50	24,00 28,80	497117	P240	100	33,15 39,78	497124	
P60	50	22,10 26,52	497118	P280	100	33,15 39,78	497204	
P80	50	20,40 24,48	497119	P320	100	33,15 39,78	497125	
P100	100	34,20 41,04	499628	P400	100	33,15 39,78	497126	
<b>Rubin 2</b>								
P40	10	5,65 6,78	499054	P40	50	23,00 27,60	499046	
P60	10	5,65 6,78	499055	P60	50	23,00 27,60	499047	
P80	10	4,90 5,88	499056	P80	50	19,90 23,88	499048	
P100	10	4,50 5,40	499057	P100	50	18,30 21,96	499049	
P120	10	4,50 5,40	499058	P120	50	18,30 21,96	499050	
P150	10	4,50 5,40	499059	P150	50	18,30 21,96	499051	
P180	10	4,50 5,40	499060	P180	50	18,30 21,96	499052	
P220	10	4,50 5,40	499061	P220	50	18,30 21,96	499053	

\* Recommended retail price of manufacturer. Dealer prices may vary.  
Excl. VAT. Incl. VAT.

# Surface treatment

## Abrasives

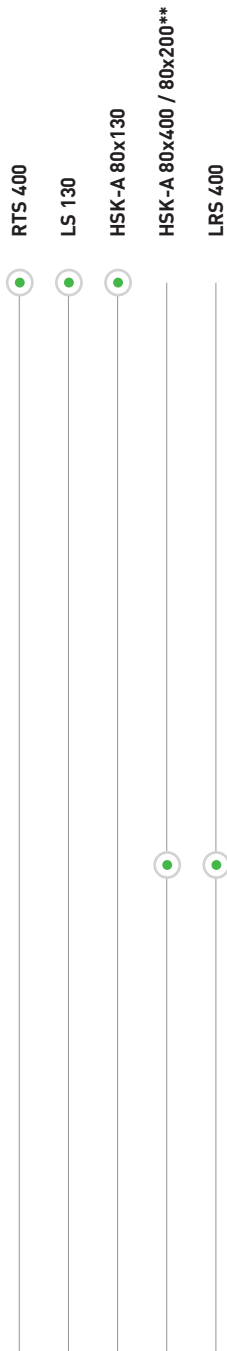

### 80 x 133 mm

#### Brilliant 2

Grit	Qty. in pack	RRP in €*	Order no.	Grit	Qty. in pack	RRP in €*	Order no.
P40	10	6,35 7,62	492859	P100	100	31,45 37,74	492851
P60	10	6,35 7,62	496008	P120	100	31,45 37,74	492852
P80	10	5,55 6,66	492860	P150	100	31,45 37,74	492853
P120	10	5,20 6,24	492861	P180	100	31,45 37,74	492854
P180	10	5,20 6,24	492862	P220	100	31,45 37,74	492855
P40	50	21,60 25,92	492848	P240	100	32,15 38,58	492856
P60	50	19,60 23,52	492849	P320	100	32,15 38,58	492857
P80	50	18,05 21,66	492850	P400	100	32,15 38,58	492858

#### Vlies

S800	5	6,85 8,22	483582
------	---	--------------	--------

### 80 x 400 mm

#### Granat



P40	50	47,05 56,46	497157	P150	50	40,55 48,66	497161
P60	50	45,15 54,18	497158	P180	50	40,55 48,66	497162
P80	50	44,15 52,98	497159	P240	50	40,55 48,66	497163
P100	50	41,75 50,10	499631	P280	50	40,55 48,66	497203
P120	50	40,55 48,66	497160	P320	50	40,55 48,66	497164

#### Titan 2

P40	50	42,05 50,46	493175	P180	50	35,30 42,36	493179
P60	50	39,90 47,88	493176	P240	50	35,30 42,36	493616
P80	50	39,25 47,10	493177	P320	50	35,30 42,36	493617
P120	50	35,30 42,36	493178				



DTS 400



100 x 150 mm								
<b>Granat</b>								
Grit	Qty. in pack	RRP in £*	Order no.	Grit	Qty. in pack	RRP in £*	Order no.	
	P40	10	8,00 9,60	497131	P120	100	42,35 50,82	497138
	P80	10	8,00 9,60	497132	P150	100	42,35 50,82	497139
	P120	10	8,00 9,60	497133	P180	100	42,35 50,82	497140
	P180	10	8,00 9,60	497134	P220	100	42,35 50,82	497141
	P40	50	30,40 36,48	497135	P240	100	42,35 50,82	497142
	P60	50	27,75 33,30	497136	P320	100	42,35 50,82	497143
	P80	50	25,85 31,02	497137	P400	100	42,35 50,82	497144
	P100	100	43,70 52,44	499630				
<b>Rubin 2</b>								
P40	10	7,60 9,12	499141	P40	50	29,50 35,40	499133	
P60	10	7,60 9,12	499142	P60	50	29,50 35,40	499134	
P80	10	6,55 7,86	499143	P80	50	25,70 30,84	499135	
P100	10	6,00 7,20	499144	P100	50	23,35 28,02	499136	
P120	10	6,00 7,20	499145	P120	50	23,35 28,02	499137	
P150	10	6,00 7,20	499146	P150	50	23,35 28,02	499138	
P180	10	6,00 7,20	499147	P180	50	23,35 28,02	499139	
P220	10	6,00 7,20	499148	P220	50	23,35 28,02	499140	
<b>Brilliant 2</b>								
P40	10	8,10 9,72	492804	P100	100	40,35 48,42	492796	
P60	10	8,10 9,72	496010	P120	100	40,35 48,42	492797	
P80	10	7,20 8,64	492805	P150	100	40,35 48,42	492798	
P120	10	6,65 7,98	492806	P180	100	40,35 48,42	492799	
P180	10	6,65 7,98	492807	P220	100	40,35 48,42	492800	
P40	50	27,65 33,18	492793	P240	100	41,25 49,50	492801	
P60	50	25,20 30,24	492794	P320	100	41,25 49,50	492802	
P80	50	23,35 28,02	492795	P400	100	41,25 49,50	492803	

\* Recommended retail price of manufacturer. Dealer prices may vary.  
Excl. VAT. Incl. VAT.

# Surface treatment

## Abrasives

RS 300  
RS 3  
LRS 93



### 93 x 178 mm

#### Granat

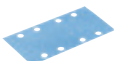

Grit	Qty. in pack	RRP in £*	Order no.	Grit	Qty. in pack	RRP in £*	Order no.
P40	50	32,75 39,30	498933	P180	100	49,70 59,64	498938
P60	50	29,75 35,70	498934	P220	100	49,70 59,64	498939
P80	50	27,65 33,18	498935	P240	100	49,70 59,64	498940
P100	100	51,10 61,32	499633	P280	100	49,70 59,64	498941
P120	100	49,70 59,64	498936	P320	100	49,70 59,64	498942
P150	100	49,70 59,64	498937	P400	100	49,70 59,64	498943
P40	10	8,15 9,78	499069	P40	50	32,00 38,40	499185
P60	10	8,15 9,78	499070	P60	50	32,00 38,40	499062
P80	10	7,10 8,52	499071	P80	50	27,95 33,54	499063
P100	10	6,45 7,74	499072	P100	50	25,40 30,48	499064
P120	10	6,45 7,74	499073	P120	50	25,40 30,48	499065
P150	10	6,45 7,74	499074	P150	50	25,40 30,48	499066
P180	10	6,45 7,74	499075	P180	50	25,40 30,48	499067
P220	10	6,45 7,74	499076	P220	50	25,40 30,48	499068
P40	10	8,10 9,72	492907	P100	100	44,75 53,70	492914
P60	10	8,10 9,72	496007	P120	100	44,75 53,70	492915
P80	10	7,20 8,64	492908	P150	100	44,75 53,70	492916
P120	10	6,55 7,86	492909	P180	100	44,75 53,70	492917
P180	10	6,55 7,86	492910	P220	100	44,75 53,70	492918
P40	50	29,50 35,40	492911	P240	100	44,75 53,70	492919
P60	50	26,85 32,22	492912	P320	100	44,75 53,70	492920
P80	50	25,00 30,00	492913	P400	100	44,75 53,70	492921

#### Rubin 2

#### Brilliant 2

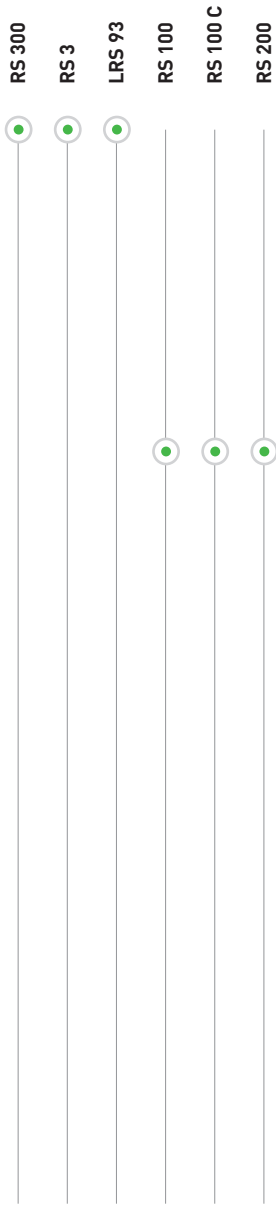

**Abrasive roll 93 mm x 14 m**

Grit	Qty. in pack	RRP in £*	Order no.	Grit	Qty. in pack	RRP in £*	Order no.
<b>Rubin 2</b>							
P40	1	46,85 56,22	499177	P120	1	39,80 47,76	499181
P60	1	46,85 56,22	499178	P150	1	39,80 47,76	499183
P80	1	41,50 49,80	499179	P180	1	39,80 47,76	499182
P100	1	39,80 47,76	499180	P220	1	39,80 47,76	499184

**115 x 228 mm**

Grit	Qty. in pack	RRP in £*	Order no.	Grit	Qty. in pack	RRP in £*	Order no.
<b>Granat</b>							
P40	50	49,70 59,64	498944	P180	100	66,45 79,74	498949
P60	50	49,70 59,64	498945	P220	100	66,45 79,74	498950
P80	50	49,70 59,64	498946	P240	100	66,45 79,74	498951
P100	100	68,50 82,20	499632	P280	100	66,45 79,74	498952
P120	100	66,45 79,74	498947	P320	100	66,45 79,74	498953
P150	100	66,45 79,74	498948	P400	100	66,45 79,74	498954
<b>Brilliant 2</b>							
P40	10	10,05 12,06	492818	P100	100	59,75 71,70	492825
P60	10	10,05 12,06	496006	P120	100	59,75 71,70	492826
P80	10	8,80 10,56	492819	P150	100	59,75 71,70	492827
P120	10	8,20 9,84	492820	P180	100	59,75 71,70	492828
P180	10	8,20 9,84	492821	P220	100	59,75 71,70	492829
P40	50	39,45 47,34	492822	P240	100	59,75 71,70	492830
P60	50	35,95 43,14	492823	P320	100	59,75 71,70	492831
P80	50	33,30 39,96	492824	P400	100	59,75 71,70	492832

\* Recommended retail price of manufacturer. Dealer prices may vary. Excl. VAT. Incl. VAT.

# Surface treatment

## Abrasives

RS 100  
RS 100 C  
RS 200  
BS 75  
BS 105  
CMB 120

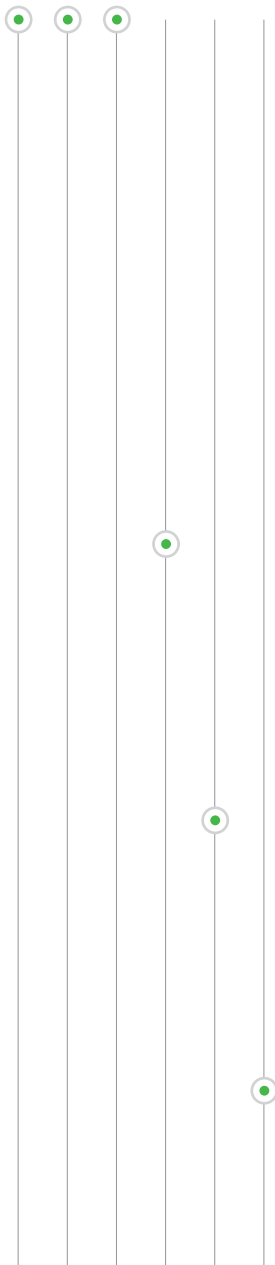

### 115 x 228 mm

#### Rubin 2

Grit	Qty. in pack	RRP in €*	Order no.	Grit	Qty. in pack	RRP in €*	Order no.
P40	10	10,90 13,08	499038	P40	50	42,85 51,42	499030
P60	10	10,90 13,08	499039	P60	50	42,85 51,42	499031
P80	10	9,45 11,34	499040	P80	50	37,15 44,58	499032
P100	10	8,55 10,26	499041	P100	50	33,85 40,62	499033
P120	10	8,55 10,26	499042	P120	50	33,85 40,62	499034
P150	10	8,55 10,26	499043	P150	50	33,85 40,62	499035
P180	10	8,55 10,26	499044	P180	50	33,85 40,62	499036
P220	10	8,55 10,26	499045	P220	50	33,85 40,62	499037

### 533 x 75 mm

#### Rubin 2

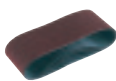

P40	10	19,25 23,10	499155	P100	10	18,30 21,96	499158
P60	10	18,90 22,68	499156	P120	10	18,30 21,96	499159
P80	10	18,50 22,20	499157	P150	10	18,30 21,96	499160

### 620 x 105 mm

#### Rubin 2



P40	10	25,80 30,96	499149	P100	10	23,50 28,20	499152
P60	10	25,15 30,18	499150	P120	10	23,50 28,20	499153
P80	10	24,30 29,16	499151	P150	10	23,50 28,20	499154

### 820 x 120 mm

#### Saphir



P50	10	61,90 74,28	488081	P120	10	55,05 66,06	488084
P80	10	61,90 74,28	488082	P150	10	55,05 66,06	488085
P100	10	55,05 66,06	488083	P180	10	55,05 66,06	488086

	Grit	Qty. in pack	RRP in £*	Order no.	Grit	Qty. in pack	RRP in £*	Order no.
<b>Pocket StickFix 46 x 178 mm for hand sanding block</b>								
	P40	10	3,95 4,74	492843	P180	10	3,15 3,78	492846
	P80	10	3,45 4,14	492844	Mix	10	3,45 4,14	492847
	P120	10	3,15 3,78	492845				

<b>Self-adhesive sanding discs Ø 36 mm</b>								
	P2000	500	169,85 203,82	500445	P3000	500	169,85 203,82	500447
	P2500	500	169,85 203,82	500446				

<b>Hand abrasive Granat soft 115 mm x 25 m</b>								
	P120	1	59,05 70,86	497091	P400	1	59,05 70,86	497096
	P150	1	59,05 70,86	497092	P500	1	59,05 70,86	497097
	P180	1	59,05 70,86	497093	P600	1	59,05 70,86	497098
	P240	1	59,05 70,86	497094	P800	1	59,05 70,86	497964
	P320	1	59,05 70,86	497095				

<b>Hand abrasive Vlies 115 x 152 mm</b>								
	P320	30	26,40 31,68	497088	P1000	30	26,40 31,68	497090
	P800	30	26,40 31,68	497089				

\* Recommended retail price of manufacturer. Dealer prices may vary.  
Excl. VAT. Incl. VAT.

# Surface treatment

## Polishing system overview

Festool polishes make polishing easy, as well as save time. Ideally suited to different kinds of polishing work, the four grades of polish guarantee optimum results

with minimum effort in combination with the appropriate Festool power tools.

### 3 steps to a perfect surface.

#### 1. Fine sanding



#### 2. Preliminary polishing

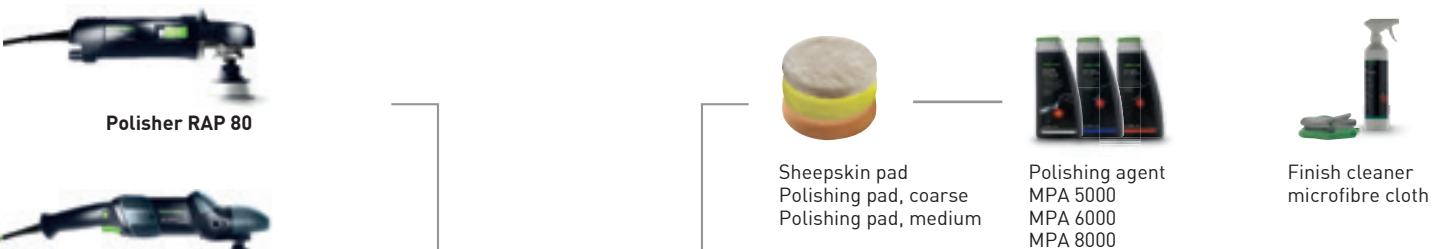

#### 3. Fine polishing

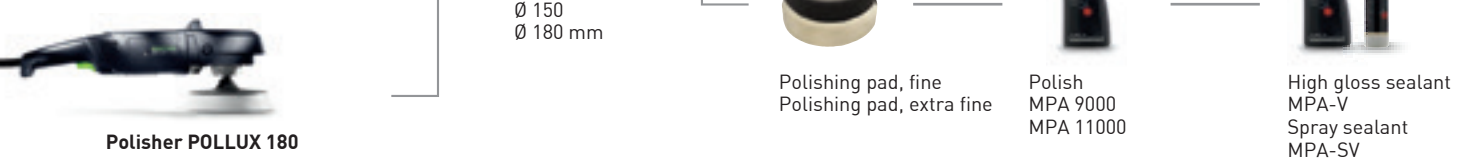

### Special applications

#### Spot repairs



#### Polishing out swirl marks



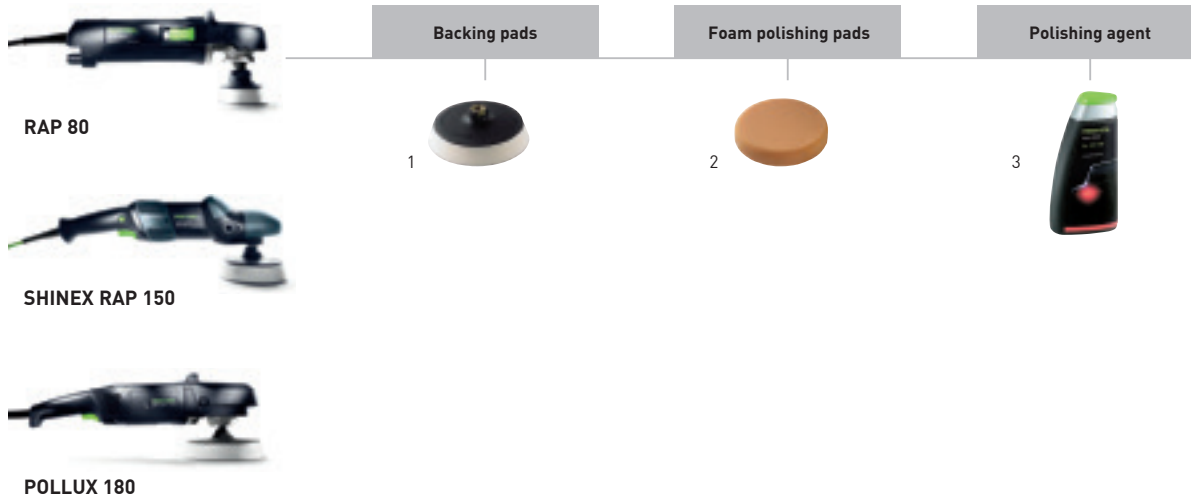











**Accessories for rotary polishers RAP 80, SHINEX RAP 150, POLLUX 180**

Denomination	Explanation	RRP in £*	Order no.
<b>1 Polishing pad PT-STF-D80-M14</b>	for RAP 80, fits polishing accessories, with integrated shock absorber for optimum distribution of pressure during polishing, Diameter 70 mm, Height 20 mm, in self-service display pack	23,00 27,60	<b>488337</b>
<b>Polishing pad PT-STF-D150-M14</b>	for RAP 150, fits polishing accessories, with integrated shock absorber for optimum distribution of pressure during polishing, Diameter 125 mm, Height 25 mm, in self-service display pack	26,50 31,80	<b>488342</b>
<b>Polishing pad PT-STF-D180-M14</b>	for RAP 180, fits polishing accessories, with integrated shock absorber for optimum distribution of pressure during polishing, Diameter 165 mm, Height 30 mm, in self-service display pack	29,70 35,64	<b>488349</b>
<b>2 Foam polishing pads</b>	from page 128		
<b>3 Polishing agent</b>	from page 126		



## Surface treatment

### Polishing agent

Polishing agent		Type	RRP in €*	Order no.
	<b>Polishing agent 1-Step</b> Speed Cut 1-step sanding polish, does not contain silicone, highly abrasive combined with high degree of gloss, volume 500 ml	MPA 5000/1	23,45 28,14 46,90 / 1 l 56,28 / 1 l	<b>499021</b>
	<b>Polishing agent</b> does not contain silicone, Sanding polish, volume 500 ml	MPA 6000/1	12,95 15,54 25,90 / 1 l 31,08 / 1 l	<b>492424</b>
	qty. in pack 6 piece(s), in a carton	MPA 6000/6	74,90 89,88 24,97 / 1 l 29,96 / 1 l	<b>492419</b>
	<b>Polishing agent</b> does not contain silicone, Fine sanding polish volume 500 ml	MPA 8000/1	15,20 18,24 30,40 / 1 l 36,48 / 1 l	<b>493816</b>
	volume 500 ml, qty. in pack 6 piece(s), in a carton	MPA 8000/6	88,30 105,96 29,43 / 1 l 35,32 / 1 l	<b>493817</b>
	canister capacity 5 kg	MPA 8000/5KG	136,50 163,80 27,30 / 1 l 32,76 / 1 l	<b>494134</b>
	<b>Polishing agent 1-Step</b> does not contain silicone, 1-step multi-purpose polish and sealant, for removing light scratches as well as sealing in a single step, volume 500 ml	MPA 9000/1	17,00 20,40 34,00 / 1 l 40,80 / 1 l	<b>496300</b>
	<b>Polishing agent</b> does not contain silicone, ceramic high-gloss polish, volume 500 ml	MPA 11000/1	17,30 20,76 34,60 / 1 l 41,52 / 1 l	<b>492427</b>
	qty. in pack 6 piece(s), in a carton	MPA 11000/6	100,90 121,08 33,63 / 1 l 40,36 / 1 l	<b>492422</b>
	<b>Sealant</b> does not contain silicone, volume 500 ml	MPA-V 0,5L	17,10 20,52 34,20 / 1 l 41,04 / 1 l	<b>495223</b>
	<b>Finish-Cleaner</b> for removing polish residues and grease marks, volume 500 ml	MPA-F	13,80 16,56 27,60 / 1 l 33,12 / 1 l	<b>493066</b>
	<b>Spray sealant</b> does not contain silicone, volume 500 ml	MPA-SV 0,5L	17,90 21,48 35,80 / 1 l 42,96 / 1 l	<b>499900</b>
	<b>Microfibre cloth</b> for excellent finish of new paints, for removing polish residues and grease marks, qty. in pack 2 piece(s)	MPA-Microfibre/2	17,70 21,24	<b>493068</b>
	<b>Cleaning cloth</b> roller with 200 sheets, fibre-reinforced, tear-proof and extremely absorbent, in dispenser box, in a carton	RT PREMIUM 240x380/200	26,75 32,10	<b>498071</b>



Self-adhesive sanding discs, spot sander and spot repair scraper

		Type	RRP in £*	Order no.
	<b>Self-adhesive sanding disc</b> for spot sander RH-SK D 32-36, self-adhesive, in a roll, Granat version, qty. in pack 500 piece(s)			
	Grit P2000	SK D32/0 P2000 GR/500	169,85 203,82	<b>500445</b>
	Grit P2500	SK D32/0 P2500 GR/500	169,85 203,82	<b>500446</b>
	Grit P3000	SK D32/0 P3000 GR/500	169,85 203,82	<b>500447</b>
	<b>Spot sander</b> for self-adhesive sanding discs D 32-36, used for holding self-adhesive sanding discs with diameter of 36 mm, for eliminating flaws	RH-SK D32-36	4,45 5,34	<b>493069</b>
		<b>Spot repair scraper</b> for the accurate removal of trapped particles and unevenness, manufactured from carbide, with hollow grinding, with cord, dimensions 25 x 30 mm	LZK-HM 52,50 63,00	<b>497525</b>

## Surface treatment

### Leave behind a brilliant impression. Festool polishes and polishing sponges.

Sensitive working and gleaming results. For high-gloss paints, UV clear coats, mineral materials or acrylic glass – with coarse to fine waffle face polishing sponges and water-based polishes. The aluminium oxide grit disintegrates during sanding, meaning the addition of silicone and wax is unnecessary.

#### Polish

- **MPA 5000** **Speed Cut 1-step sanding polish**  
High abrasiveness with high gloss at the same time
- **MPA 6000** **Sanding polish**
- **MPA 8000** **Fine sanding polish**
- **MPA 9000** **1-Step multi-purpose polish**  
For removing light scratches and sealing in a single step, produces high gloss finish
  
- **MPA 11000** **Ceramic high-gloss polish**  
Very fine
- **MPA-V** **High-gloss sealant**  
For sealing surfaces
- MPA-SV** **Sealing spray**  
For sealing surfaces instantly



#### Foam polishing pads



**Coarse**  
For polishing heavily weathered surfaces (in preparation for painting)



**Mid**  
for preliminary polishing when repairing paint flaws



**Fine**  
For preliminary polishing and finishing when removing dust pockets and for high-gloss polish



**Fine, waffle face**  
For preliminary polishing and finishing when removing dust pockets and for polishing out swirl marks



**Extra fine, waffle face**  
For polishing out swirl marks and for high-gloss polish

#### Polishing felt and sheepskin pad



**Hard polishing felt**  
for preliminary polishing of mineral materials, acrylic glass and gloss paints



**Premium sheepskin**  
Suitable for UV paints, scratch-resistant paints

**Soft polishing felt**  
For re-polishing mineral materials, acrylic glass and gloss paints

#### Perfect down to the last detail – microfibre cloths and finish cleaner







High-quality microfibre cloths with scratch-free edge generate the perfect painted finish. In combination with finish cleaner, they are ideal for removing polish residues and grease spots.



RAP 80, T 15+3, T 18+3

RO 90 DX









		Diameter	Height	qty. in pack	RRP in £*	Order no.
<b>PoliStick for Ø 80 mm</b>						
	yellow, Coarse, for polishing heavily weathered surfaces (preparation for painting)	80 mm	20 mm	5	19,15 22,98	493842
	orange, Mid, for preliminary polishing when repairing paint flaws	80 mm	20 mm	5	20,80 24,96	493849
	white, Fine, For preliminary polishing and finishing when removing trapped dust and for buffing	80 mm	20 mm	5	19,15 22,98	493863
	white, fine (honeycombed), For preliminary polishing and finishing when removing dust inclusions, for polishing out holograms	80 mm	20 mm	5	20,05 24,06	493870
	black, very fine (honeycombed), for polishing out holograms, for high-gloss polish	80 mm	20 mm	5	19,05 22,86	493884
	Premium sheepskin, genuine sheepskin pad, Suitable for UV paints, scratch-resistant paints, lint-free	80 mm	20 mm	5	32,25 38,70	493835
	Polishing felt, white, hard, for preliminary polishing of mineral materials, acrylic glass and gloss paints	80 mm	6 mm	5	16,80 20,16	488339
	white, soft, for re-polishing mineral materials, acrylic glass and gloss paints	80 mm	6 mm	5	16,80 20,16	488341

## Surface treatment

### Polishing accessories

RO 125











		Diameter	Height	qty. in pack	RRP in €*	Order no.
<b>PoliStick for Ø 125 mm</b>						
	yellow, Coarse, for polishing heavily weathered surfaces (preparation for painting)	125 mm	20 mm	5	35,30 42,36	<b>493844</b>
	orange, Mid, for preliminary polishing when repairing paint flaws	125 mm	20 mm	1	11,40 13,68	<b>493850</b>
	white, Fine, For preliminary polishing and finishing when removing trapped dust and for buffing	125 mm	20 mm	1	9,95 11,94	<b>493864</b>
		125 mm	20 mm	5	43,80 52,56	<b>493865</b>
	white, fine (honeycombed), For preliminary polishing and finishing when removing dust inclusions, for polishing out holograms	125 mm	20 mm	1	10,45 12,54	<b>493871</b>
	black, very fine (honeycombed), for polishing out holograms, for high-gloss polish	125 mm	20 mm	1	8,50 10,20	<b>493885</b>
	Premium sheepskin, genuine sheepskin pad, Suitable for UV paints, scratch-resistant paints, lint-free	125 mm	20 mm	1	10,70 12,84	<b>493836</b>
	Polishing felt, white, hard, for preliminary polishing of mineral materials, acrylic glass and gloss paints	125 mm	6 mm	5	22,00 26,40	<b>493078</b>
		125 mm	6 mm	5	22,00 26,40	<b>493077</b>

RAP 150

RO 150



PoliStick for Ø 150 mm		Diameter	Height	qty. in pack	RRP in £*	Order no.
	yellow, Coarse, for polishing heavily weathered surfaces (preparation for painting)	150 mm	30 mm	5	51,80 62,16	493846
	orange, Mid, for preliminary polishing when repairing paint flaws	150 mm	30 mm	1	14,90 17,88	493852
		150 mm	30 mm	5	66,25 79,50	493853
	white, Fine, For preliminary polishing and finishing when removing trapped dust and for buffing	150 mm	30 mm	1	12,10 14,52	493866
		150 mm	30 mm	5	51,80 62,16	493867
	white, Fine, with edge	150 mm	20 mm	5	47,00 56,40	495180
	white, fine (honeycombed), For preliminary polishing and finishing when removing dust inclusions, for polishing out holograms	150 mm	30 mm	1	12,60 15,12	493873
		150 mm	30 mm	5	56,10 67,32	493874
	black, very fine (honeycombed), for polishing out holograms, for high-gloss polish	150 mm	30 mm	1	11,50 13,80	493887
		150 mm	30 mm	5	51,40 61,68	493888
	Premium sheepskin, genuine sheepskin pad, Suitable for UV paints, scratch-resistant paints, lint-free	150 mm	20 mm	1	12,70 15,24	493838
	Polishing felt, white, hard, for preliminary polishing of mineral materials, acrylic glass and gloss paints	150 mm	6 mm	1	7,20 8,64	485970
	white, hard, for preliminary polishing of mineral materials, acrylic glass and gloss paints	150 mm	6 mm	5	27,75 33,30	488348
	white, soft, For re-polishing mineral materials, acrylic glass and gloss paints	150 mm	6 mm	1	7,20 8,64	485972
		150 mm	6 mm	5	27,75 33,30	488347







## Surface treatment

### Polishing accessories

POLLUX 180

RAP 180



		Diameter	Height	qty. in pack	RRP in €*	Order no.
<b>PoliStick for Ø 180 mm</b>						
	yellow, Coarse, for polishing heavily weathered surfaces (preparation for painting)	180 mm	30 mm	5	76,65 91,98	<b>493848</b>
	orange, Mid, for preliminary polishing when repairing paint flaws	180 mm	30 mm	1	17,50 21,00	<b>493854</b>
		180 mm	30 mm	5	78,30 93,96	<b>493855</b>
	white, Fine, For preliminary polishing and finishing when removing trapped dust and for buffing	180 mm	30 mm	1	18,15 21,78	<b>493868</b>
	white, fine (honeycombed), For preliminary polishing and finishing when removing dust inclusions, for polishing out holograms	180 mm	30 mm	1	19,15 22,98	<b>493875</b>
		180 mm	30 mm	5	85,05 102,06	<b>493876</b>
	black, very fine (honeycombed), for polishing out holograms, for high-gloss polish	180 mm	30 mm	5	73,40 88,08	<b>493890</b>
	Premium sheepskin, genuine sheepskin pad, Suitable for UV paints, scratch-resistant paints, lint-free	180 mm	20 mm	1	19,60 23,52	<b>493840</b>
	Polishing felt, hard, for preliminary polishing of mineral materials, acrylic glass and gloss paints	180 mm	6 mm	5	49,30 59,16	<b>488355</b>
	white, soft, for re-polishing mineral materials, acrylic glass and gloss paints	180 mm	6 mm	5	49,30 59,16	<b>488354</b>

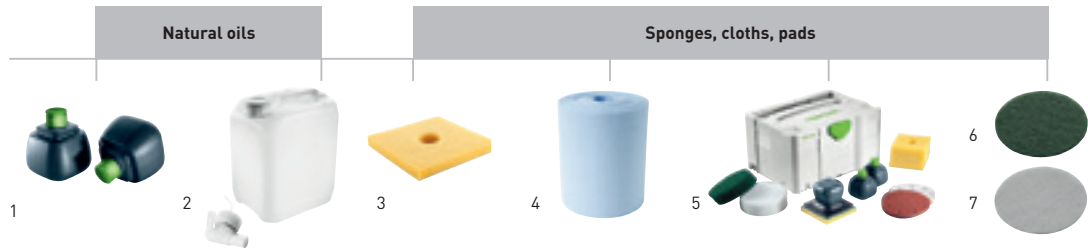

### Accessories for SURFIX OS oil dispenser

Denomination	Explanation	RRP in £*	Order no.
<b>1 Natural oil RF HD 0,3 l/2</b>	heavy-duty oil, refill bottle, volume 300 ml, qty. in pack 2 piece(s), in self-service display pack	23,90 28,68 39,83 / 1 l 47,80 / 1 l	<b>498064</b>
<b>Natural oil RF OS 0,3 l/2</b>	one-step oil, refill bottle, volume 300 ml, qty. in pack 2 piece(s), in self-service display pack	23,90 28,68 39,83 / 1 l 47,80 / 1 l	<b>498065</b>
<b>Natural oil RF OD 0,3 l/2</b>	outdoor oil, refill bottle, volume 300 ml, qty. in pack 2 piece(s), in self-service display pack	23,90 28,68 39,83 / 1 l 47,80 / 1 l	<b>498066</b>
<b>2 Natural oil RF HD 5l</b>	heavy-duty oil, filling quantity 5 l, in canister	113,15 135,78 22,63 / 1 l 27,16 / 1 l	<b>498067</b>
<b>Natural oil RF OS 5l</b>	one-step oil, filling quantity 5 l, in canister	113,15 135,78 22,63 / 1 l 27,16 / 1 l	<b>498068</b>
<b>Natural oil RF OD 5l</b>	outdoor oil, filling quantity 5 l, in canister	113,15 135,78 22,63 / 1 l 27,16 / 1 l	<b>498069</b>
<b>3 Oil sponge OS-STF 125x125/5</b>	StickFix sponge for SURFIX oil dispenser, qty. in pack 5 piece(s), dimensions 125 x 125 mm, in a carton	14,45 17,34	<b>498070</b>
<b>4 Cleaning cloth RT PREMIUM 240x380/200</b>	roller with 200 sheets, fibre-reinforced, tear-proof and extremely absorbent, in dispenser box, in a carton	26,75 32,10	<b>498071</b>
<b>5 Oil dispenser OS-SYS3-Set</b>	Oil dispenser OS-Set HD 0,3l, one-step oil bottle, 0.3 l, outdoor oil bottle, 0.3 l, base plate, 5x oil sponges, 5x green sanding cloths, 5x white sanding cloths, 10x STF-D150 P180 RU2 sanding discs, 10x STF-D150 P240 BR2 sanding discs, in a SYSTAINER SYS 3 T-LOC	113,15 135,78	<b>498063</b>
<b>6 Sanding vlies STF D125/0 green/10</b>	for grinding in and evenly distributing oil on the surface, Grit green, qty. in pack 10 piece(s), Diameter 125 mm, in a carton	21,80 26,16	<b>496510</b>
<b>Sanding vlies STF D150/0 green/10</b>	for grinding in and evenly distributing oil on the surface, Grit green, qty. in pack 10 piece(s), Diameter 150 mm, in a carton	26,75 32,10	<b>496508</b>
<b>7 Polishing fleece STF D125/0 white/10</b>	For re-polishing and further surface refinement, without grit, Grit white, qty. in pack 10 piece(s), Diameter 125 mm, in a carton	21,80 26,16	<b>496511</b>
<b>Polishing fleece STF D150/0 white/10</b>	For re-polishing and further surface refinement, without grit, Grit white, qty. in pack 10 piece(s), Diameter 150 mm, in a carton	26,75 32,10	<b>496509</b>





## Routing

<b>Overview of products and applications</b>	136
<b>Routers</b> OF 1010, OF 1400, OF 2200, CMS-OF	138
<b>Bench-mounted routers</b> TF 1400, TF 2200	143
<b>Multi-routing templates</b> MFS 400, MFS 700	144
<b>Worktop template</b> APS	145
<b>Jointing system</b> VS 600 GE	146
<b>Hole series system</b> LR 32	147
<b>Edging system</b> OF-FH 2200	148
<b>Laminate trimmers</b> OFK 500, OFK 700	149
<b>Module edge router</b> MFK 700	151
<b>Putty router</b> KF 5	152
<b>Aluminium composite milling machine</b> PF 1200	153
<b>Accessories and consumable materials</b>	154
The Festool system	

# Routing

## Overview of products and applications

Rounding off corners, routing cut-outs, profiles and grooves – tasks best performed using a perfectly adapted range of routers and laminate trimmers.

Page 138 — 139 — 140 — 143 — 143

OF 1010

OF 1400

OF 2200

TF 1400

TF 2200



### Applications

#### Routers

#### Bench-mounted routers

Routing cut-outs and circles with MFS



Worktop corner joints with APS



Routing corner joints with VS 600



Use with the hole series system



Routing shapes using a template



Routing small curves and profiles



Routing large curves and profiles



Routing joins, rebates and grooves



Processing mineral materials



Routing edge veneer flush with straight workpieces



Routing edge veneer flush on curved workpieces



Flush-routing of laminate



Removal of window putty and glass remnants



Routing accurate grooves in aluminium composite panels



### Technical data

	1010	1400	2200	1400	2200
Power consumption (W)	1010	1400	2200	1400	2200
Idle engine speed (rpm)	10000-24000	10000-22500	10000-22000	10000-225000	10000-22000
Collets Ø (mm)	6-8	6-12,7	6-12,7		
Routing depth adjustment range (mm)	55	70	80		
Fine height adjustment range (mm)	8	8	20		
Max. cutter Ø (mm)	50	63	89	60	60
Connection Ø d/e (mm)	27	27/36	36/27	27/36	27/36
Weight (kg)	2,7	4,5	7,8	25,4	29,4
Table dimensions (mm)				585 x 400	585 x 400

149 — 150 — 151 — 152 — 153

**OFK 500**      **OFK 700**      **MFK 700**      **KF 5**      **PF 1200**



Laminate trimmers

Putty router

Aluminium composite milling machine

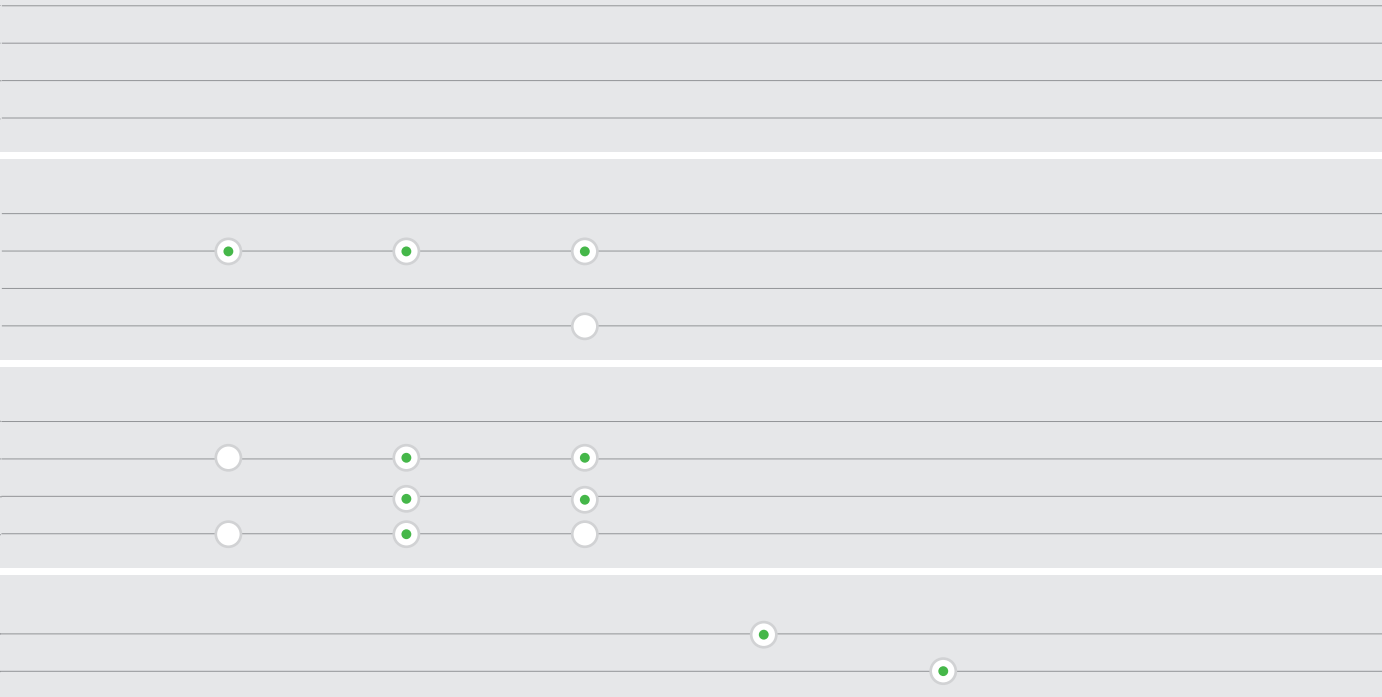

Extremely appropriate     Appropriate

	450	720	720	1010	1200
	28000	10000-26000	10000-26000	10000-24000	1900-5200
		6-8	6-8		
				55	
			14	8	
	28	26	32	50	118
	27	27	27	27	27/36
	1,4	2,0	1,9	3,1	5,4

## Routing

Router OF 1010



product  
design  
award

2001

# OF 1010



### A host of features for perfect working results.

Whether guided independently or on the guide rail, the OF 1010 is the perfect one-handed router. Compact and lightweight, you can guide it accurately along edges, lines or curves, using only one hand.



### Small tool for delicate tasks.

- ▶ Outstanding ergonomics and low weight
- ▶ Handle for easy one-handed operation
- ▶ Routing depth adjustment to 1/10 mm
- ▶ Maximum safety: safety brake stops the cutter promptly

#### Technical data

Power consumption [W]	1010
Idle engine speed [min <sup>-1</sup> ]	10000-24000
Collet Ø (mm)	6-8
Routing depth adjustment range (mm)	55
Fine height adjustment range (mm)	8
Max. cutter diameter (mm)	50
Connection Ø d/e (mm)	27
weight [kg]	2,7



= with MMC electronics

Items Included	RRP in £*	Order no.
Ø 1/4" clamping collet (6.35 mm), Ø 8 mm clamping collet, side stop, guide rail adapter, chip deflector, operation tool, in a SYSTAINER SYS 3 T-LOC		
<b>OF 1010 EQ-Set GB 110V</b> guide rail FS 800/2	367,00 440,40	<b>574377</b>
<b>OF 1010 EQ-Plus GB 110V</b>	343,00 411,60	<b>574338</b>
<b>OF 1010 EBQ-Plus GB 240V</b>	343,00 411,60	<b>574334</b>
<b>OF 1010 EBQ-Set GB 240V</b> guide rail FS 800/2	367,00 440,40	<b>574374</b>

\* Recommended retail price of manufacturer. Dealer prices may vary.  
Excl. VAT.  
Incl. VAT.

#### System accessories from page 156



#### Cutters from page 164





design award  
winner  
2003

OF 1400

03

**Power and ease of operation in perfect harmony.**

- ▶ Pure precision: rigid base plate due to guide columns on both sides
- ▶ Short set-up times: ratchet principle for fast router bit changes
- ▶ Routing depth adjustment to 1/10 mm
- ▶ Maximum safety: safety brake stops the cutter promptly

**Technical data**

Power consumption (W)	1400
Idle engine speed (min <sup>-1</sup> )	10000-22500
Collet Ø (mm)	6-12,7
Routing depth adjustment range (mm)	70
Fine height adjustment range (mm)	8
Max. cutter diameter (mm)	63
Connection Ø d/e (mm)	27/36
weight (kg)	4,5



☐ = with MMC electronics

Items Included	RRP in £*	Order no.
Ø 1/4" clamping collet (6.35 mm), Ø 1/2" clamping collet (12.7 mm), side stop with fine setting, copying ring Ø 30 mm, extraction hood, top, chip deflector, operation tool, in a SYSTAINER SYS 4 T-LOC		
<b>OF 1400 EBQ-Plus GB 240V</b>	471,00 565,20	<b>574345</b>
<b>OF 1400 EQ-Plus GB 110V</b>	471,00 565,20	<b>574344</b>



**An impressive all-in-one package.**

At 4.5 kg, the OF 1400 is the lightest in its class and has an impressive 70 mm routing depth adjustment range. This is particularly useful when making recesses for fittings or routing with templates.

\* Recommended retail price of manufacturer. Dealer prices may vary.  
Excl. VAT.  
Incl. VAT.

**System accessories  
from page 157**



**Cutters  
from page 164**

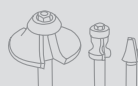

## Routing

Router OF 2200



product  
design  
award

2008

# OF 2200



### Unrivalled performance and operation.

More powerful, easier to use, increased comfort and safer – the OF 2200 offers the greatest low-end torque, the highest precision and ergonomic comfort due to features such as guide rods offset by 30° to transfer the force more efficiently. No matter what your application is, the OF 2200 is the perfect solution.



### The power pack with enormous torque.

- ▶ Top power development and fully variable speed for hard materials and increased material thicknesses
- ▶ Outstanding ergonomics: guide rods offset by 30° to transfer force efficiently
- ▶ Pure precision: rigid base plate due to guide columns on both sides
- ▶ Maximum safety: safety brake stops the cutter promptly

#### Technical data

Power consumption [W]	2200
Idle engine speed [min <sup>-1</sup> ]	10000-22000
Collet Ø [mm]	6-12,7
Routing depth adjustment range [mm]	80
Fine height adjustment range [mm]	20
Max. cutter diameter [mm]	89
Connection Ø d/e [mm]	36/27
weight [kg]	7,8



= with MMC electronics

Items Included	RRP in £*	Order no.
Ø 1/4" clamping collet (6.35 mm), Ø 1/2" clamping collet (12.7 mm), copying ring Ø 30 mm, chip deflector, operation tool, in a SYSTAINER SYS 4 T-LOC		
<b>OF 2200 EB-Plus GB 240V</b>	661,00 793,20	<b>574352</b>
<b>OF 2200 EB-Plus GB 110V</b>	661,00 793,20	<b>574353</b>
<b>OF 2200 EB-Set GB 240V</b>	909,00	<b>574395</b>
accessories SYSTAINER (Order No. 497655)	1.090,80	
<b>OF 2200 EB-Set GB 110V</b>	909,00	<b>574396</b>
accessories SYSTAINER (Order No. 497655)	1.090,80	

\* Recommended retail price of manufacturer. Dealer prices may vary.  
Excl. VAT.  
Incl. VAT.

#### System accessories from page 158



#### Cutters from page 164





## Adapted to the task in hand.

Festool offers a compatible range of routers and laminate trimmers for every task. A range that not only includes tools, but also a wide selection of ingenious system accessories. Interchangeable copying rings and base runners, for example, allow you to adapt your machine to changing task requirements. Multifunctional routing templates can be adjusted to any dimension both quickly and accurately, while routers OF 1010, 1400 and 2200 can be converted into bench-mounted routers. All of these solutions were developed following close collaboration with the handicraft trade – bringing you closer to the perfect result with greater speed and efficiency.

03

### Quick response to changing requirements.

Base runners and copying rings for the OF 1400/OF 2200 can be replaced quickly using FastFix without requiring tools. Changing router bits is also a simple matter, thanks to the ratcheting mechanism, which allows you to either tighten or release the router bit without having to turn the open ended spanner.



### Cleaner, healthier work.

The new suction design behind the OF 2200 ensures suction power of up to 99%. The retractable extractor ring seals off the chip space when the router is used in plunge mode. However, the ring can be locked in place on top for a perfect view of the scribe mark. The chip deflector can be rotated 360° and ensures maximum suction power.

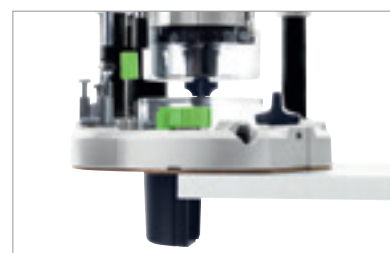

### Impeccable guidance.

The guide rail was invented and perfected by Festool. For enhanced precision of grooves and rows of holes. Fitted with slideway lining to allow machines to glide smoothly along the rail, plus a groove for fastening and lever clamps.



## Routing

Module mounting CMS-OF



# CMS-OF



### From mobile to stationary in a matter of seconds.

With the CMS module, standard routers can be transformed into bench-mounted routers suitable for a wide range of applications. The transparent routing guard guarantees efficient dust extraction while also providing a good view of the workpiece.

### Router for the CMS system.

- ▶ Module mounting for installing routers
- ▶ The router can be used not only as a bench-mounted tool, but also as a handheld tool
- ▶ Simple routing height adjustment with a crank handle
- ▶ Flexible extension options – for an even wider range of applications

#### Technical data

Max. cutter diameter (mm)	60
Dimensions (mm)	578 x 320
weight (kg)	10,1

Items Included	RRP in £*	Order no.
module support, assembly lugs, router stop, press-down fixture, guard, in a carton		
<b>CMS-OF</b>	453,00 543,60	<b>570251</b>

\* Recommended retail price of manufacturer. Dealer prices may vary.  
Excl. VAT.  
Incl. VAT.

**CMS system overview**  
from page 348



**System accessories**  
from page 366

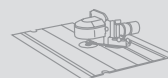





# TF 1400 / TF 2200

03

### The system bench-mounted router.

- ▶ Complete set consisting of a basic unit, module mounting and router
- ▶ The router can be used not only as a bench-mounted tool, but also as a handheld tool
- ▶ Simple routing height adjustment with a crank handle
- ▶ Flexible extension options – for an even wider range of applications

Technical data	TF 1400	TF 2200
Power consumption (W)	1400	2200
Idle engine speed (min <sup>-1</sup> )	10000-22500	10000-22000
Max. cutter diameter (mm)	60	60
Table dimensions (mm)	585 x 400	585 x 400
Dimensions module support (mm)	578 x 320	578 x 320
Table height, legs unfolded (mm)	900	900
Table height, legs folded away (mm)	316	316
Working height with legs (mm)	900	900
Connection Ø d/e (mm)	27/36	27/36
Basic unit weight (kg)	10,8	10,8
Weight (set) (kg)	25,4	29,4



■ = with MMC electronics



### Comfortable routing of conventional profiles.

Low space requirements combined with powerful and precise performance make the bench-mounted router ideal for series production. The extensive range of shank cutters with varying geometries enable you to process strips, profiles and medium to large workpieces in a professional manner.

System accessories  
from page 366



Cutters  
from page 164



This product is not available in Great Britain.

## Routing

The MFS routing template



# MFS



### A multi-talent.

The laborious manufacture of templates or temporary solutions has become a thing of the past: the MFS multi-routing template is versatile and perfect for curves, round or square cut-outs and routing staircase stringers.

### The template with all the options.

- ▶ Scale on the profiles accurate to the millimetre for absolute precision when making cut-outs and curves
- ▶ Aligned exactly with the workpiece – via the angle stops
- ▶ Secured quickly – workpiece secured in prefabricated groove for fastening and lever clamps
- ▶ Option of systematic extension – with table extensions from 200 mm to 2000 mm

Items Included	RRP in £*	Order no.
2 angle stops, tilt protection, circle routing insert, operation tool, in a carton		
<b>MFS 400</b>	190,05 228,06	<b>492610</b>
<b>MFS 700</b>	297,45 356,94	<b>492611</b>

\* Recommended retail price of manufacturer. Dealer prices may vary.  
Excl. VAT.  
Incl. VAT.

**System accessories**  
from page 159

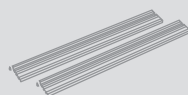

**Cutters**  
from page 164

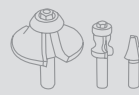



APS

03

### Precision as standard.

- ▶ For corner and panel joints up to 900 mm deep
- ▶ For routing normal connection fittings on the undersides of panels
- ▶ Panel widths greater than 900 mm also possible using extension profiles



Items Included	RRP in £*	Order no.
corner connection template, profile MFS-VP 1000, 3 bolts, operation tool, in a carton		
<b>APS 900</b>	247,85 297,42	<b>492727</b>

\* Recommended retail price of manufacturer. Dealer prices may vary.  
Excl. VAT.  
Incl. VAT.

**Cutters**  
from page 164



### Flush joints.

Clean corner and panel joints are easy to manufacture with the worktop template. The permanently fixed template guarantees precision results, even when the router passes several times along a single groove.

## Routing

### Joining system VS 600

## VS 600 GE



### Eternal precision.

The joining system VS 600 is an exceptionally logical method of achieving perfect wood-working results. Offering outstanding precision for partially covered and open dovetail joints, box joints and custom-fit dowelling joints.



### Combining tradition with efficiency.

- ▶ Perfection in a system: router, template and copying ring are fully compatible with one another
- ▶ Wide application spectrum: from dovetail joints and box joints to dowelling joints
- ▶ Templates changed quickly and easily without using tools
- ▶ Robust aluminium design and steel contact jaws ensure an extended service life

#### Technical data

Workpiece thickness (depending on join) (mm)	6-30
Maximum workpiece length (mm)	650

Items Included	RRP in £*	Order no.
in a carton		
<b>VS 600 GE</b>	319,25 383,10	<b>488876</b>

\* Recommended retail price of manufacturer. Dealer prices may vary.  
Excl. VAT.  
Incl. VAT.

Routing templates  
from page 160

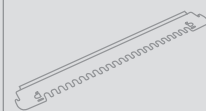

Cutters  
from page 164



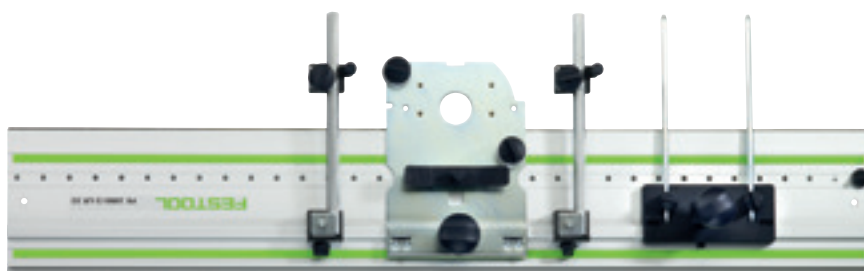

# LR 32

03



### Holes in series.

- ▶ With the LR 32 system – comprising the guide rail FS 1400/2-LR 32 or FS 2424/2-LR 32 and the hole drilling system – precise rows of holes spaced 32 mm apart can be drilled with the Festool router
- ▶ The LR 32 guide rail is aligned quickly and parallel to the two side stops, which are positioned by means of an adjustable stop at the workpiece and guide rail

Items Included	RRP in £*	Order no.
guide plate, centring mandrel, 2 longitudinal stops		
<b>LR 32 Set</b>	173,05	<b>583290</b>
2 parallel side fence, in a carton	207,66	
<b>LR 32-SYS</b>	338,90	<b>584100</b>
operation tool, hinge location cutter HM Ø 35 mm, dowel drill HW Ø 5 mm (V-shaped tip), dowel drill HM Ø 5 mm (with centring bit and pre-cutter), 2 parallel side fences with adjustable stop, 2 clamps FSZ 120, in a SYSTAINER SYS 1 T-LOC	406,68	

### Precise hole rows with the guide rail.

Series of holes must agree in terms of distance and parallelism. To save time when carrying out this type of work, there is the hole row guide rail. It has a series of holes set 32 mm apart, along which the router is guided with the hole row adapter. Thanks to the clever tipping method, the detent pin can be quickly indexed for the next hole. The series of holes are therefore very easy to copy.

\* Recommended retail price of manufacturer. Dealer prices may vary.  
Excl. VAT.  
Incl. VAT.

### System accessories from page 161

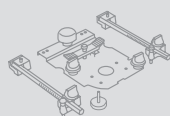

## Routing

Edge trimming system



# OF-FH 2200



### Routing door seals.

The grooving of doors is often still considered as a task for bench-mounted routers. With the Festool routing aid and the router, the work can be carried out on site achieving results which are not inferior to those of bench-mounted routers. And thanks to the integral dust extraction, the environment also remains free of wood dust.

### Reliable and precise cutting for intumescent grooves.

- ▶ For secure guidance of the Festool router along narrow workpiece edges
- ▶ Side stops can be adjusted 60 mm on both sides with long guidance areas
- ▶ High-quality cutter device made from sturdy and solid acrylic glass
- ▶ Used, for example, for the reliable milling of automatic door seals

Items Included	RRP in £*	Order no.
in a carton		
<b>OF-FH 2200</b>	163,55 196,26	<b>495246</b>

\* Recommended retail price of manufacturer. Dealer prices may vary.  
Excl. VAT.  
Incl. VAT.

**System accessories**  
from page 161

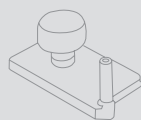



OFK 500

03



### Compact edging professional.

- ▶ Easy to handle and lightweight
- ▶ Perfect adaptation of cutter to borehole in bench to prevent routing errors
- ▶ Stable connection between cutter and drive mechanism for maximum true-running precision
- ▶ Spindle stop for quick and easy cutter changes

#### Technical data

Power consumption (W)	450
Idle engine speed (min <sup>-1</sup> )	28000
Max. cutter diameter (mm)	28
Connection Ø d/e (mm)	27
weight (kg)	1,4



Items Included	RRP in £*	Order no.
ogee cutter HW R3-OFK, extraction hood, in a SYSTAINER SYS 2 T-LOC		
<b>OFK 500 Q-Plus R3 GB 240V</b>	267,00 320,40	<b>574358</b>

### For trimming round objects.

The OFK 500 is particularly lightweight and perfectly balanced, making it manoeuvrable and ideal for both vertical and horizontal use. The small distance between the cutter and router base prevents the machine from tipping over edges, guaranteeing perfect results.

\* Recommended retail price of manufacturer. Dealer prices may vary.  
Excl. VAT.  
Incl. VAT.

#### System accessories from page 162



#### Cutters from page 164



## Routing

Edge router OFK 700

# OFK 700



### Impressive both on curves and in straight lines.

The OFK 700 EQ is a multi-talent among edge trimmers because it makes easy work of trimming edges and surface projections, irrespective of whether the workpiece is large or small, or whether the edges are curved or straight. The quick, heavy-duty detachable router table provides a stable surface area and secure guidance for the machine in any working position.



### Edging multi-talent.

- ▶ Detachable router table with large support surface
- ▶ Base inclined by 1.5° for excellent working results
- ▶ Routing depth adjustment to 1/10 mm
- ▶ Contact spring for smooth routing pattern

#### Technical data

Power consumption (W)	720
Idle engine speed (min <sup>-1</sup> )	10000-26000
Max. cutter diameter (mm)	26
Collet Ø (mm)	6-8
Maximum cutting depth, vertical (mm)	9
Maximum cutting depth, horizontal (mm)	5
Max. routing width (mm)	14
Connection Ø d/e (mm)	27
weight (kg)	2



☐ = with MMC electronics

Items Included	RRP in £*	Order no.
Ø 1/4" clamping collet (6.35 mm), Ø 8 mm clamping collet, extraction hood, edge trimming cutter D 19 x 16, operation tool, in a SYSTAINER SYS 2 T-LOC		
<b>OFK 700 EQ-Plus GB 240V</b>	448,00 537,60	<b>574362</b>

\* Recommended retail price of manufacturer. Dealer prices may vary.  
Excl. VAT.  
Incl. VAT.

#### System accessories from page 162



#### Cutters from page 164







# MFK 700

03



### Versatile when trimming edges.

- ▶ Wider application spectrum due to interchangeable router tables
- ▶ Efficient dust extraction integrated directly on the router base
- ▶ Contact spring for smooth routing pattern
- ▶ 130 mm table support surface for precision routing results

#### Technical data

Power consumption (W)	720
Idle engine speed (min <sup>-1</sup> )	10000-26000
Collet Ø (mm)	6-8
Fine height adjustment range (mm)	14
Max. cutter diameter (mm)	32
Connection Ø d/e (mm)	27
weight (kg)	1,9



■ = with MMC electronics

Items Included	RRP in £*	Order no.
Ø 1/4" clamping collet (6.35 mm), Ø 8 mm clamping collet, parallel side fence with fine adjustment and extraction hood, 1.5° router table, tarnishing pad, extraction hood, operation tool, in a SYSTAINER SYS 2 T-LOC		
<b>MFK 700 EQ-Set GB 240V</b>	435,00 522,00	<b>574366</b>
<b>MFK 700 EQ-Set GB 110V</b>	435,00 522,00	<b>574365</b>

### Wonderfully changeable.

A modular design makes the MFK 700 edge router module one of the most cost-effective tools money can buy – only the router table needs to be replaced, not the entire router – and it is best equipped for all applications involving the routing of corners and edges. In just a few steps, install the required router table and then you are ready to route edge veneer or grooves, round off corners, make profiles and much more.

\* Recommended retail price of manufacturer. Dealer prices may vary.  
Excl. VAT.  
Incl. VAT.

#### System accessories from page 162



#### Cutters from page 164



## Routing

### Putty router KF 5

KF 5



### Window renovation made easy.

The KF 5 putty router quickly removes glass splinters, putty, adhesive and sealant without leaving unwanted residues. The combination of special splinterguard and dust extractor protects the user and the environment. A selection of suitable rebating cutters are available for processing different types of window – for reglazing double-glazed windows, for example.

### The re-glazing professional.

- ▶ Routing depth adjustment to 1/10 mm
- ▶ Maximum safety: safety brake stops the cutter promptly
- ▶ Metal splinterguard prevents injuries from glass splinters, nails and putty residues
- ▶ Handle for easy one-handed operation

#### Technical data

Power consumption (W)	1010
Idle engine speed (min <sup>-1</sup> )	10000-24000
Routing depth adjustment range (mm)	55
Fine height adjustment range (mm)	8
Max. cutter diameter (mm)	50
Connection Ø d/e (mm)	27
weight (kg)	3,1



= with MMC electronics

Items Included	RRP in £*	Order no.
Ø 8 mm clamping collet, operation tool, in a SYSTAINER SYS 3 T-LOC		
<b>KF 5 EBQ-Plus GB 240V</b>	627,00 752,40	<b>574380</b>

\* Recommended retail price of manufacturer. Dealer prices may vary.  
Excl. VAT.  
Incl. VAT.

#### System accessories from page 163

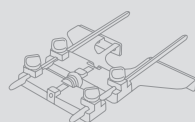

#### Cutters from page 164





PF 1200

03



### Grooving. Edging. Finished.

Specially developed for edging aluminium composite panels with speed and precision. In combination with the guide rail, the PF 1200 aluminium composite milling machine is ideal for mobile exhibition and façade construction applications. The feeler roller ensures precise routing depths. The router can only plunge into the material as far as the feeler roller allows.

### The professional solution for aluminium composite panels.

- ▶ Removable feeder roller for different material thicknesses
- ▶ Low weight for easy transportation and mobile applications
- ▶ Guide slot for guide rail
- ▶ Blade cutter for rapid progress and effortless precision routing

#### Technical data

Power consumption (W)	1200
Idle engine speed (min <sup>-1</sup> )	1900-5200
Routing depth (mm)	0-9
Max. cutter diameter (mm)	118
Connection Ø d/e (mm)	27/36
weight (kg)	5,4



☐ = with MMC electronics

Items Included	RRP in £*	Order no.
V-grooving bit, setting gauge for guide rails, operation tool, without guide rails, in a SYSTAINER SYS 4 T-LOC		
<b>PF 1200 E-Plus Alucobond GB</b>	1.508,00	<b>574390</b>
A4 feeler roller	1.809,60	
<b>PF 1200 E-Plus Dibond GB</b>	1.508,00	<b>574391</b>
D3 feeler roller	1.809,60	

\* Recommended retail price of manufacturer. Dealer prices may vary.  
Excl. VAT.  
Incl. VAT.

#### Cutters from page 163



### The Festool system.

Because things work better when everything fits together:

The comprehensive range of system accessories for routers and laminate trimmers leaves nothing to be desired and helps accelerate working processes. From the hole series guide rail, which can also be used with plunge-cut saws and jigsaws, to perfectly adapted cutters and a large selection of copying rings and base runners for a range of applications.



## Routing

Accessories and consumable materials

System accessories	156
Cutters	164



# Routing

## System accessories

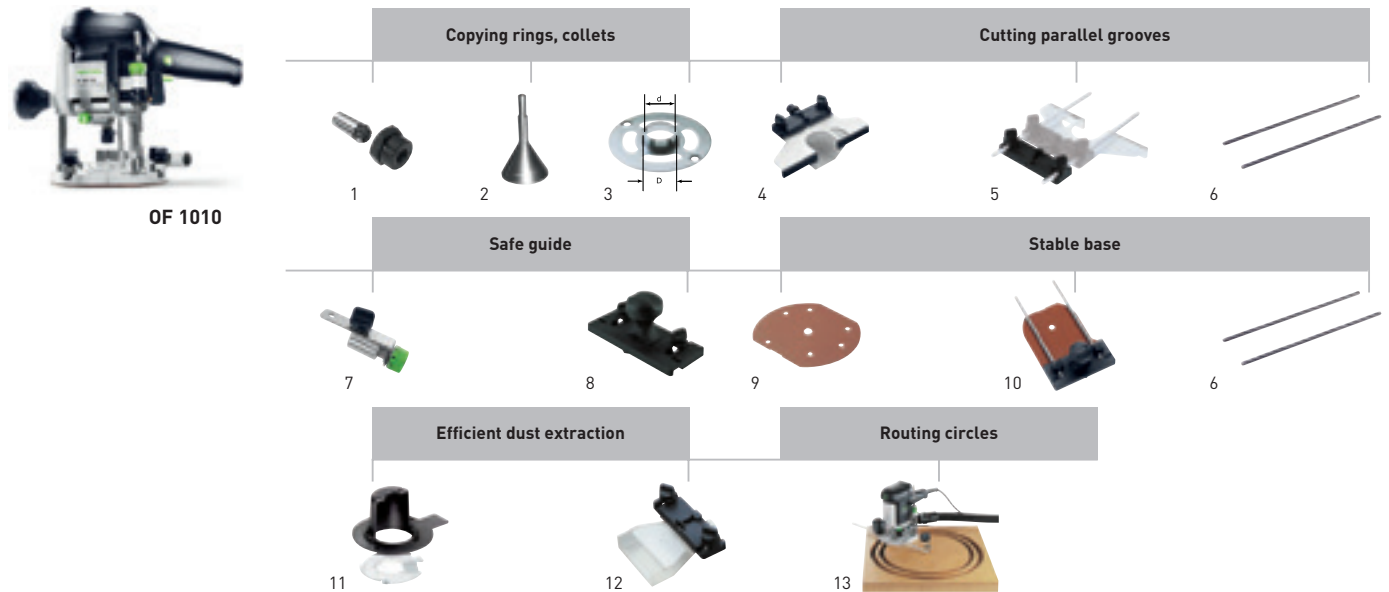

### Accessories for router OF 1010

Denomination	Explanation	RRP in £*	Order no.
<b>1 Collet SZ-D 6/OF 1000</b>	for MFK/OFK 700, OF 900, OF 1000, OF 1010, KF, with locking nut, for cutter shank $\varnothing$ 6 mm, in self-service display pack	34,40 41,28	<b>488760</b>
<b>Collet SZ-D 6,35/OF 1000</b>	for MFK/OFK 700, OF 900, OF 1000, OF 1010, KF, with locking nut, for cutter shank $\varnothing$ 6.35 mm (1/4"), in self-service display pack	34,40 41,28	<b>488761</b>
<b>Collet SZ-D 8/OF 1000</b>	for MFK/OFK 700, OF 900, OF 1000, OF 1010, KF, with locking nut, for router shank $\varnothing$ 8 mm, in self-service display pack	34,40 41,28	<b>488755</b>
<b>2 Centring mandrel ZD-OF/D 6,35+8</b>	for all Festool routers, for shank support $\varnothing$ 6.35 mm and 8 mm for centring the copying rings, in self-service display pack	17,30 20,76	<b>492187</b>
<b>3 Copying ring KR-D 10,8/OF 900</b>	for OF 900, OF 1000, OF 1010, KF, D 10,8 mm, $\varnothing$ 7,8 mm, in self-service display pack	8,30 9,96	<b>486029</b>
<b>Copying ring KR-D 13,8/OF 900</b>	for OF 900, OF 1000, OF 1010, KF, D 13,8 mm, $\varnothing$ 10,8 mm, in self-service display pack	8,30 9,96	<b>484176</b>
<b>Copying ring KR-D17/OF 900</b>	for OF 900, OF 1000, OF 1010, KF, D 17 mm, $\varnothing$ 14 mm, in self-service display pack	8,30 9,96	<b>486030</b>
<b>Copying ring KR-D 24/OF 900</b>	for OF 900, OF 1000, OF 1010, KF, D 24 mm, $\varnothing$ 21 mm, in self-service display pack	8,30 9,96	<b>486031</b>
<b>Copying ring KR-D 27/OF 900</b>	for OF 900, OF 1000, OF 1010, KF, D 27 mm, $\varnothing$ 24 mm, in self-service display pack	8,30 9,96	<b>486032</b>
<b>Copying ring KR-D 30/OF 900</b>	for OF 900, OF 1000, OF 1010, KF, D 30 mm, $\varnothing$ 27 mm, in self-service display pack	8,30 9,96	<b>486033</b>
<b>Copying ring KR-D 40/OF 900</b>	for OF 900, OF 1000, OF 1010, KF, D 40 mm, $\varnothing$ 37 mm, in self-service display pack	8,30 9,96	<b>486034</b>
<b>4 Parallel side fence SA-OF 1000</b>	for OF 900, OF 1000, OF 1010, KF, in a carton	32,00 38,40	<b>489427</b>
<b>5 Fine adjuster for parallel side fence FE-OF 1000/KF</b>	for OF 900, OF 1000, OF 1010, KF, for fast and dimensionally accurate adjustment on the parallel side fence, can be retrofitted, delivered without side stop and guide rods, in self-service display pack	25,00 30,00	<b>483358</b>
<b>6 Guide rods</b>	Included in the OF 1010 delivery		
<b>7 Fine adjuster for guide stop FE-FS/OF 1000</b>	for OF 900, OF 1000, OF 1010, KF, in self-service display pack	18,75 22,50	<b>488754</b>
<b>8 Guide rail adapter FS-OF 1000</b>	for use of routers OF 900, OF 1000, OF 1010 with the FS guidance system, complete with support, in self-service display pack	27,50 33,00	<b>488752</b>
<b>9 Hard fibre base runner TP-OF</b>	for OF 900, OF 1000, OF 1010, KF, centre hole $\varnothing$ 15 mm, in self-service display pack	11,30 13,56	<b>489229</b>
<b>10 Extension table TV-OF 1000</b>	for OF 900, OF 1000, OF 1010, KF, to increase the bearing surface when working on edges, delivered without guide rods, in self-service display pack	28,35 34,02	<b>488756</b>
<b>11 Chip deflector KSF-OF 1010</b>	for OF 900, OF 1000, OF 1010, for sideway extraction, aperture max. 37 mm, in self-service display pack	18,95 22,74	<b>493180</b>
<b>12 Dust extraction attachment AH-OF 1000</b>	for OF 900, OF 1000, OF 1010, KF, for jointing system VS 500 / VS 600 and for edge trimming, in a carton	16,20 19,44	<b>484453</b>
<b>13 Trammel unit SZ-OF 1000</b>	for OF 900, OF 1000, OF 1010, KF, for cutting radii, circles and decorative curves on surfaces and edges, circle $\varnothing$ 153 – 760 mm, in self-service display pack	16,80 20,16	<b>483922</b>

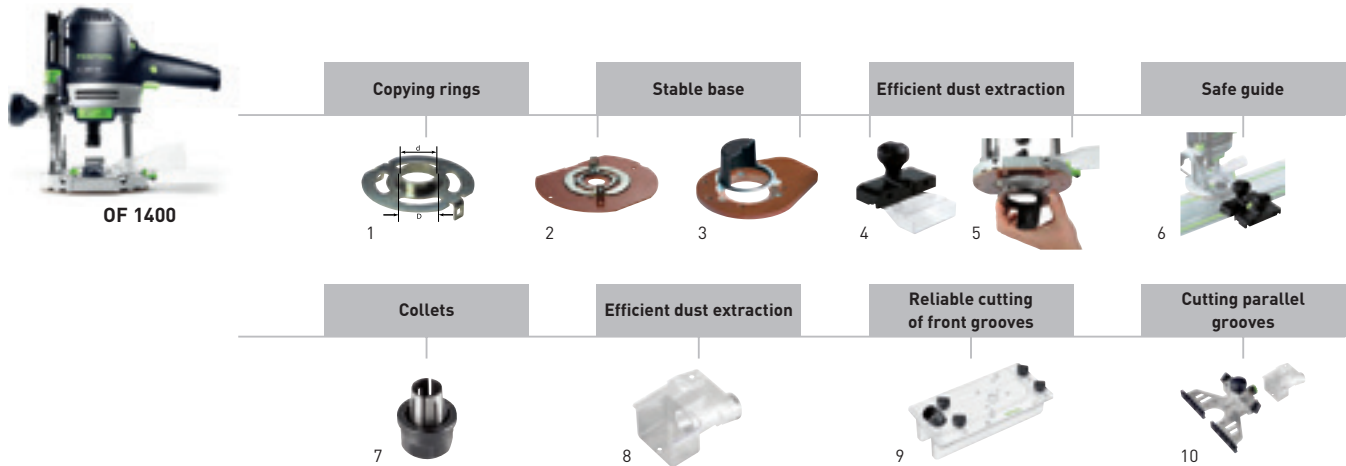

### Accessories for router OF 1400

Denomination	Explanation	RRP in €*	Order no.
<b>1 Copying ring KR-D 17,0/OF 1400</b>	for OF 1400, D 17 mm, Ø 14 mm, in self-service display pack	13,65 16,38	<b>493315</b>
<b>Copying ring KR-D 24,0/OF 1400</b>	for OF 1400, D 24 mm, Ø 21 mm, in self-service display pack	13,90 16,68	<b>492183</b>
<b>Copying ring KR-D 27,0/OF 1400</b>	for OF 1400, D 27 mm, Ø 24 mm, in self-service display pack	13,90 16,68	<b>492184</b>
<b>Copying ring KR-D 30,0/OF 1400</b>	for OF 1400, D 30 mm, Ø 27 mm, in self-service display pack	13,90 16,68	<b>492185</b>
<b>Copying ring KR-D 40,0/OF 1400</b>	for OF 1400, D 40 mm, Ø 37 mm, in self-service display pack	13,90 16,68	<b>492186</b>
<b>Copying ring KR-D 8,5/OF 1400</b>	for OF 1400 / VS 600, D 8,5 mm, Ø 6,5 mm, in self-service display pack	13,90 16,68	<b>492179</b>
<b>Copying ring KR-D 13,8/OF 1400</b>	for OF 1400 / VS 600, D 13,8 mm, Ø 10,8 mm, in self-service display pack	13,90 16,68	<b>492180</b>
<b>Copying ring KR-D 17,0/OF 1400</b>	for OF 1400 / VS 600, D 17 mm, Ø 14 mm, in self-service display pack	13,90 16,68	<b>492181</b>
<b>Copying ring KR-D 24,0/OF 1400</b>	for OF 1400 / VS 600, D 24 mm, Ø 21 mm, in self-service display pack	13,90 16,68	<b>492182</b>
<b>2 Base runner LA-OF 1400</b>	for OF 1400, hard-fibre base runner with 20 mm centre bore, reduces the opening of the router to the cutter diameter, max. cutter diameter 37 mm, in self-service display pack	22,75 27,30	<b>492574</b>
<b>3 Running pad with chip deflector LAS-OF 1400</b>	for OF 1400, for sideways extraction, running pad with support extension, aperture max. 63 mm, in a carton	83,20 99,84	<b>493233</b>
<b>4 Dust extraction attachment AH-OF 1400</b>	for OF 1400 / VS 600, for sideways extraction, in a carton	38,65 46,38	<b>492585</b>
<b>5 Chip deflector KSF-OF 1400</b>	for OF 1400, for sideways extraction, in self-service display pack	18,80 22,56	<b>492732</b>
<b>6 Guide rail adapter FS-OF 1400</b>	for OF 1400, with fine adjustment and support for router without guide rods, in a carton	46,80 56,16	<b>492601</b>
<b>7 Collet SZ-D 6,0/OF 1400/2000/2200</b>	for the OF 1400, OF 2000, OF 2200, for cutter shank Ø 6 mm, in self-service display pack	40,65 48,78	<b>494459</b>
<b>Collet SZ-D 8,0/OF 1400/2000/2200</b>	for the OF 1400, OF 2000, OF 2200, for router shank Ø 8 mm, in self-service display pack	40,65 48,78	<b>494460</b>
<b>Collet SZ-D 10,0/OF 1400/2000/2200</b>	for the OF 1400, OF 2000, OF 2200, for cutter shank Ø 10 mm, in self-service display pack	40,65 48,78	<b>494461</b>
<b>Collet SZ-D 12,0/OF 1400/2000/2200</b>	for the OF 1400, OF 2000, OF 2200, for cutter shank Ø 12 mm, in self-service display pack	40,65 48,78	<b>494462</b>
<b>Collet SZ-D 6,35/OF 1400/2000/2200</b>	for the OF 1400, OF 2000, OF 2200, for router shaft 6.35 mm, in self-service display pack	40,65 48,78	<b>494463</b>
<b>Collet SZ-D 9,53/OF 1400/2000/2200</b>	for the OF 1400, OF 2000, OF 2200, for router shaft 9.53 mm, in self-service display pack	40,65 48,78	<b>494464</b>
<b>Collet SZ-D 12,7/OF 1400/2000/2200</b>	for the OF 1400, OF 2000, OF 2200, for router shaft Ø 12.7 mm, in self-service display pack	40,65 48,78	<b>494465</b>
<b>8 Dust extraction attachment AH-SA-OF 2000</b>	for the OF 1400, OF 2000, OF 2200, extractor hood for parallel side fence, in a carton	24,75 29,70	<b>489565</b>
<b>9 Routing aid OF-FH 2200</b>	for OF 900, OF 1000, OF 1010, OF 1400, OF 2000, OF 2200, safe guidance of the router thanks to the movable legs, in a carton	163,55 196,26	<b>495246</b>
<b>10 Parallel side fence SA-OF 1400</b>	for OF 1400, With fine adjustment and extraction hood, without rods, in a carton	46,30 55,56	<b>492636</b>

# Routing

## System accessories

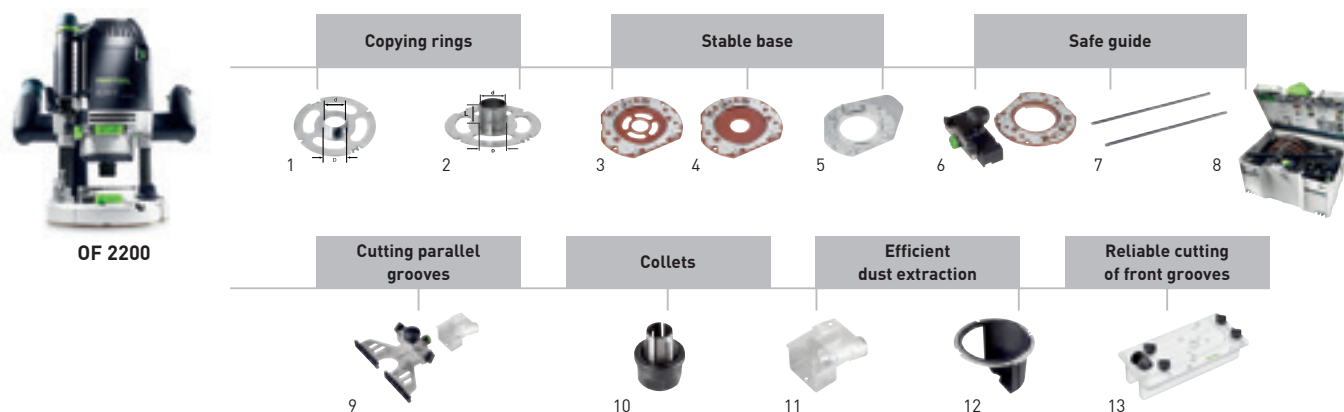

### Accessories for the OF 2200 router

Denomination	Explanation	RRP in €*	Order no.
<b>1 Copying ring KR-D 17,0/OF 2200</b>	for OF 2200, D 17 mm, Ø 15 mm, in self-service display pack	13,25 15,90	<b>494622</b>
<b>Copying ring KR-D 24,0/OF 2200</b>	for OF 2200, D 24 mm, Ø 22 mm, in self-service display pack	13,25 15,90	<b>494623</b>
<b>Copying ring KR-D 27,0/OF 2200</b>	for OF 2200, D 27 mm, Ø 24 mm, in self-service display pack	13,25 15,90	<b>494624</b>
<b>Copying ring KR-D 30,0/OF 2200</b>	for OF 2200, D 30 mm, Ø 27 mm, in self-service display pack	13,25 15,90	<b>494625</b>
<b>Copying ring KR-D 40,0/OF 2200</b>	for OF 2200, D 40 mm, Ø 37 mm, in self-service display pack	13,25 15,90	<b>494626</b>
<b>2 Copying ring KR-D 30,0/21,5/OF 2200</b>	for OF 2200, extra long safety copying ring D30, 21 mm high, required for use of reversible blade cutters 497455 and 497456, D 30 mm, Ø 27 mm, in self-service display pack	23,45 28,14	<b>497453</b>
<b>3 Base runner LA-OF 2200 D36 CT</b>	for OF 2200, for copying rings < 30 mm, With openings for optimised extraction, in a carton	42,30 50,76	<b>494675</b>
<b>4 Base runner LA-OF 2200 D36</b>	for OF 2200, reduces the opening of the router to the cutter diameter, in a carton	42,30 50,76	<b>494677</b>
<b>5 Support AFB-OF 2200</b>	for OF 2200, support widener for safe guidance of the router at workpiece edges, in a carton	50,55 60,66	<b>494682</b>
<b>6 Guide rail adapter FS-OF 2200</b>	for OF 2200, with fine adjustment and support plate for router, without guide rods ST-OF 2200/2, in a carton	91,60 109,92	<b>494681</b>
<b>7 Rod ST-OF 2200/2</b>	for OF 2200, guide rods for side and guide stops 2 pieces, in self-service display pack	15,20 18,24	<b>495247</b>
<b>8 Accessories set ZS-OF 2200 M</b>	for OF 2200, guide rail adapter set, parallel side fence with fine adjustment and extraction hood, Guide rods, copying ring Ø 17 mm, copying ring Ø 24 mm, copying ring Ø 27 mm, copying ring Ø 40 mm, base runner D36, base runner for copying rings, extension, in a SYSTAINER SYS 3 T-LOC	303,15 363,78	<b>497655</b>
<b>9 Parallel side fence SA-OF 2200</b>	for OF 2200, With fine adjustment and extraction hood, Without guide rods ST-OF 2200/2, in a carton	77,30 92,76	<b>494680</b>
<b>10 Collet SZ-D 6,0/OF 1400/2000/2200</b>	for the OF 1400, OF 2000, OF 2200, for cutter shank Ø 6 mm, in self-service display pack	40,65 48,78	<b>494459</b>
<b>Collet SZ-D 8,0/OF 1400/2000/2200</b>	for the OF 1400, OF 2000, OF 2200, for router shank Ø 8 mm, in self-service display pack	40,65 48,78	<b>494460</b>
<b>Collet SZ-D 10,0/OF 1400/2000/2200</b>	for the OF 1400, OF 2000, OF 2200, for cutter shank Ø 10 mm, in self-service display pack	40,65 48,78	<b>494461</b>
<b>Collet SZ-D 12,0/OF 1400/2000/2200</b>	for the OF 1400, OF 2000, OF 2200, for cutter shank Ø 12 mm, in self-service display pack	40,65 48,78	<b>494462</b>
<b>Collet SZ-D 6,35/OF 1400/2000/2200</b>	for the OF 1400, OF 2000, OF 2200, for router shaft 6.35 mm, in self-service display pack	40,65 48,78	<b>494463</b>
<b>Collet SZ-D 9,53/OF 1400/2000/2200</b>	for the OF 1400, OF 2000, OF 2200, for router shaft 9.53 mm, in self-service display pack	40,65 48,78	<b>494464</b>
<b>Collet SZ-D 12,7/OF 1400/2000/2200</b>	for the OF 1400, OF 2000, OF 2200, for router shaft Ø 12.7 mm, in self-service display pack	40,65 48,78	<b>494465</b>
<b>11 Dust extraction attachment AH-SA-OF 2000</b>	for the OF 1400, OF 2000, OF 2200, extractor hood for parallel side fence, in a carton	24,75 29,70	<b>489565</b>
<b>12 Chip deflector KSF-OF 2200</b>	for OF 2200, for sideways extraction, max. cutter diameter 80 mm, in self-service display pack	40,05 48,06	<b>494670</b>
<b>13 Routing aid OF-FH 2200</b>	for OF 900, OF 1000, OF 1010, OF 1400, OF 2000, OF 2200, safe guidance of the router thanks to the movable legs, in a carton	163,55 196,26	<b>495246</b>



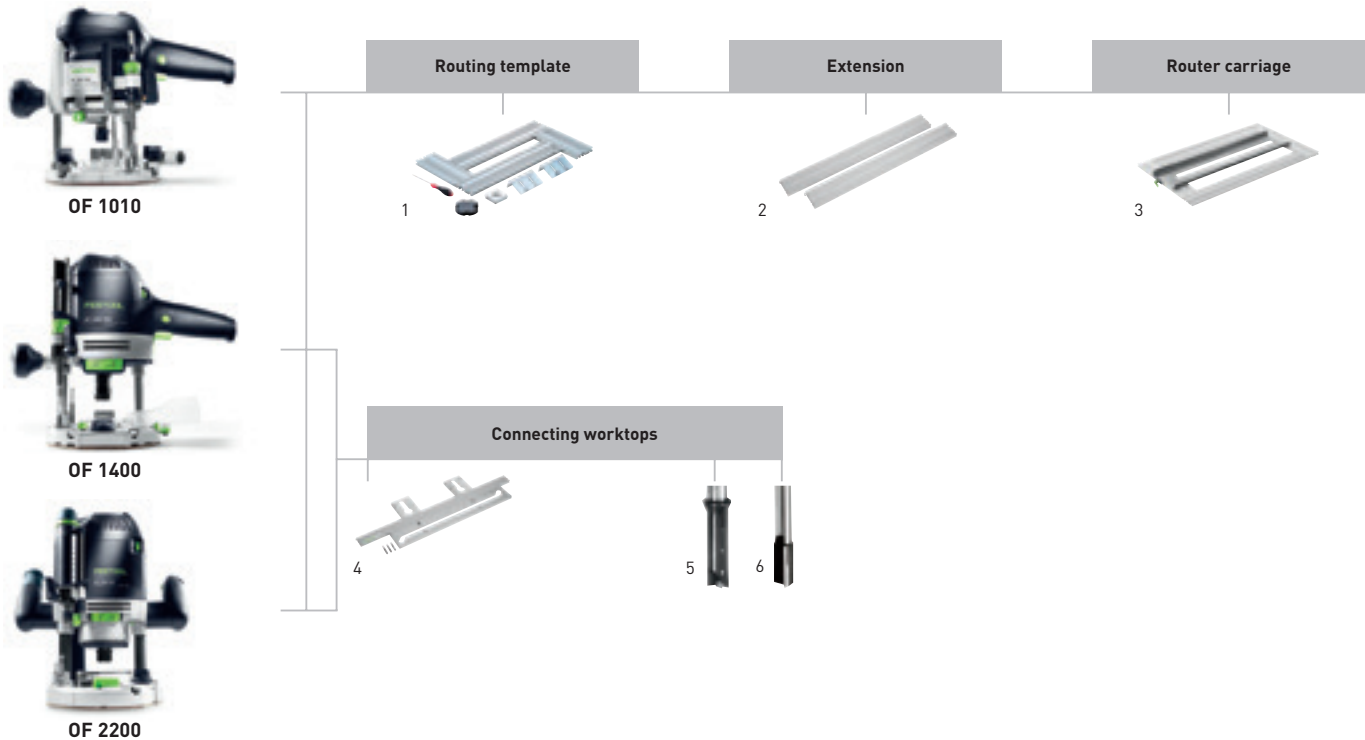

### Accessories for multi-routing template MFS

Denomination	Explanation	RRP in £*	Order no.
<b>1 Routing template MFS 400</b>	for all routers with copying ring, for rectangular (300 x 100 mm) or curved (Ø 600 mm) cut-outs, 2 angle stops, tilt protection, circle routing insert, operation tool, in a carton	190,05 228,06	<b>492610</b>
<b>Routing template MFS 700</b>	for all routers with copying ring, for rectangular (max. 600 x 300 mm) or curved (max. Ø 1200 mm) cut-outs, 2 angle stops, tilt protection, circle routing insert, operation tool, in a carton	297,45 356,94	<b>492611</b>
<b>2 Extension profile MFS-VP 200</b>	for extension of MFS 400, MFS 700, with scale, 2x profile 200 mm, longitudinal connectors, in a carton	70,60 84,72	<b>492722</b>
<b>Extension profile MFS-VP 400</b>	for extension of MFS 400, MFS 700, with scale, 2x profile 400 mm, longitudinal connectors, in a carton	82,60 99,12	<b>492723</b>
<b>Extension profile MFS-VP 700</b>	for extension of MFS 400, MFS 700, with scale, 2x profile 700 mm, longitudinal connectors, in a carton	145,95 175,14	<b>492724</b>
<b>Extension profile MFS-VP 1000</b>	for extension of MFS 400, MFS 700, with scale, 2x profile 1000 mm, longitudinal connectors, in a carton	173,40 208,08	<b>492725</b>
<b>Extension profile MFS-VP 2000</b>	for extension of MFS 400, MFS 700, without scale, 2x profile 2000 mm, longitudinal connectors, in a carton	215,10 258,12	<b>492726</b>
<b>3 Router carriage MFS-FS</b>	for MFS 400, MFS 700, for large-surface routing, traverse path 600 mm, Ø copy ring 30 mm, in a carton	106,65 127,98	<b>495648</b>
<b>4 Worktop template APS 900</b>	for corner and panel connectors with depths of up to 900 mm, for diameter of cutter 14 mm and copying ring 30 mm, corner connection template, profile MFS-VP 1000, 3 bolts, operation tool, in a carton	247,85 297,42	<b>492727</b>
<b>5 Reversible blade groove cutter HW shank 12 mm HW S12 D14/45 WM</b>	for OF 2200, D 14 mm, NL 45 mm, GL 105 mm, in self-service display pack	171,30 205,56	<b>491110</b>
<b>6 Edge trimming cutter HW shank 12 mm HW S12 D14/50</b>	D 14 mm, NL 50 mm, GL 100 mm, in self-service display pack	77,75 93,30	<b>491089</b>

# Routing

## System accessories

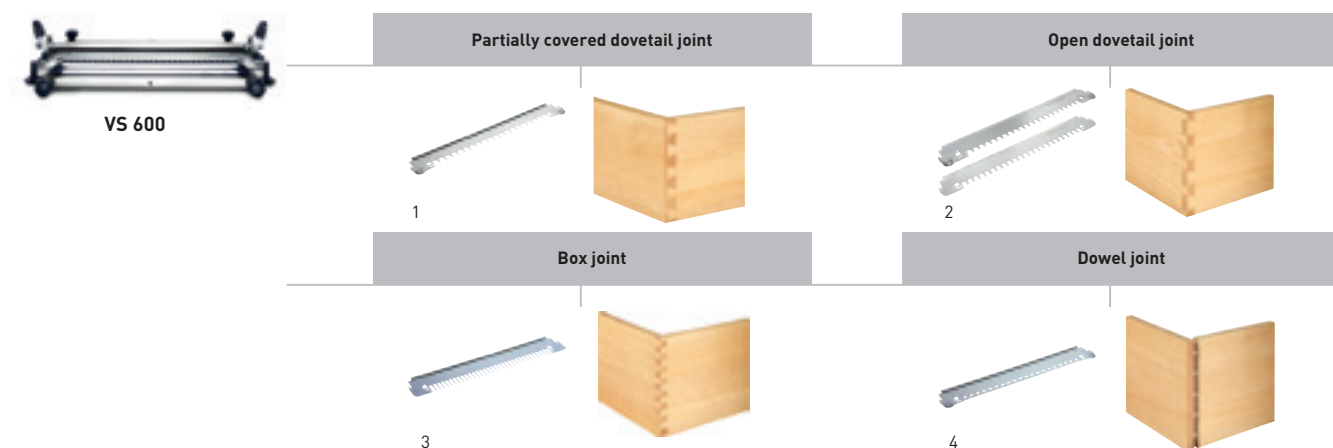

### Routing templates and cutters for jointing system VS 600

Denomination	Explanation	RRP in £*	Order no.
<b>1 Dovetail joint template VS 600 SZ 14</b>	for OF 1010, OF 1400, for blind dovetail joints, tenon size 14 mm, copying ring Ø 17 mm (for OF 1010), workpiece thickness 14 – 20 mm, in a carton	61,40 73,68	<b>488877</b>
<b>Dovetail cutter HS shank 8 mm HS S8 D13,8/13,5/15°</b>	for semi-covered dovetail joints SZ 14, D 13,8 mm, NL 13,5 mm, GL 46 mm, alpha 15 °, in self-service display pack	18,85 22,62	<b>490991</b>
<b>Dovetail cutter HW shank 8 mm HW S8 D13,8/13,5/15°</b>	for semi-covered dovetail joints SZ 14, D 13,8 mm, NL 13,5 mm, GL 46 mm, alpha 15 °, in self-service display pack	32,85 39,42	<b>490992</b>
<b>Dovetail joint template VS 600 SZ 20</b>	for OF 1010, OF 1400, for blind dovetail joints, tenon size 20 mm, copying ring Ø 24 mm (for OF 1010), workpiece thickness 21 – 28 mm, in a carton	61,40 73,68	<b>488878</b>
<b>Dovetail cutter HS shank 8 mm HS S8 D20/17/15°</b>	for semi-covered dovetail joints SZ 20, D 20 mm, NL 17 mm, GL 49 mm, alpha 15 °, in self-service display pack	28,25 33,90	<b>490995</b>
<b>Dovetail cutter HW shank 8 mm HW S8 D20/17/15°</b>	for semi-covered dovetail joints SZ 20, D 20 mm, NL 17 mm, GL 49 mm, alpha 15 °, in self-service display pack	37,40 44,88	<b>490996</b>
<b>2 Template-kit VS 600 SZO 14</b>	for OF 1010, OF 1400, open dovetail joint, slot size 14 mm, copying ring Ø 8.5 mm (for OF 1010), copying ring Ø 17 mm (for OF 1010), workpiece thickness 10 – 14 mm, in a carton	105,90 127,08	<b>491152</b>
<b>Dovetail cutter HW shank 8 mm HW S8 D14,3/16/10°</b>	for open dovetail joints SZO 14, D 14,3 mm, NL 16 mm, GL 50 mm, alpha 10 °, in self-service display pack	34,20 41,04	<b>491164</b>
<b>Spiral groove cutter HW shank 8 mm HW Spi S8 D6/16</b>	for slot joints FZ 6 and open dovetail joints SZO 14 with fine precision in diameter, D 6 mm, NL 21 mm, GL 50 mm, in self-service display pack	44,65 53,58	<b>490978</b>
<b>Template-kit VS 600 SZO 20</b>	for OF 1010, OF 1400, for exposed dovetail joints, tenon size 20 mm, copying ring Ø 13.8 mm (for OF 1010), copying ring Ø 24 mm (for OF 1010), workpiece thickness 14 – 25 mm, in a carton	105,90 127,08	<b>491153</b>
<b>Dovetail cutter HW shank 8 mm HW S8 D20/26/10°</b>	for open dovetail joint slots, SZO 20, D 20 mm, NL 26 mm, GL 58 mm, alpha 10 °, in self-service display pack	39,90 47,88	<b>491165</b>
<b>Spiral groove cutter HW shank 8 mm HW Spi S8 D10/30</b>	for slot joints FZ 10 and open dovetail joints SZO 20 with fine precision in diameter, D 10 mm, NL 30 mm, GL 60 mm, in self-service display pack	55,30 66,36	<b>490980</b>
<b>3 Slot joint template VS 600 FZ 6</b>	for OF 1010, OF 1400, for slot joint connections, tenon size 6 mm, copying ring Ø 8.5 mm (for OF 1010), workpiece thickness 6 – 10 mm, in a carton	55,05 66,06	<b>488879</b>
<b>Spiral groove cutter HW shank 8 mm HW Spi S8 D6/16</b>	for slot joints FZ 6 and open dovetail joints SZO 14 with fine precision in diameter, D 6 mm, NL 21 mm, GL 50 mm, in self-service display pack	44,65 53,58	<b>490978</b>
<b>Spiral groove cutter HS shank 8 mm HS Spi S8 D6/16</b>	for slot joints FZ 6 and open dovetail joints SZO 14 with fine precision in diameter, D 6 mm, NL 16 mm, GL 50 mm, in self-service display pack	21,60 25,92	<b>490944</b>
<b>Slot joint template VS 600 FZ 10</b>	for OF 1010, OF 1400, for slot joint connections, tenon size 10 mm, copying ring Ø 13.8 mm (for OF 1010), workpiece thickness 10 – 20 mm, in a carton	55,05 66,06	<b>488880</b>
<b>Spiral groove cutter HW shank 8 mm HW Spi S8 D10/30</b>	for slot joints FZ 10 and open dovetail joints SZO 20 with fine precision in diameter, D 10 mm, NL 30 mm, GL 60 mm, in self-service display pack	55,30 66,36	<b>490980</b>
<b>Spiral groove cutter HS shank 8 mm HS Spi S8 D10/30</b>	for slot joints FZ 10 and open dovetail joints SZO 20 with fine precision in diameter, D 10 mm, NL 30 mm, GL 60 mm, in self-service display pack	25,00 30,00	<b>490946</b>
<b>4 Jointing system dowel joint unit VS 600 DS 32</b>	for OF 1010, OF 1400, dowelling joint in the 32 grid, copying ring Ø 13.8 mm (for OF 1010), in a carton	61,40 73,68	<b>488881</b>
<b>Dowel drill HW shank 8 mm HW S8 D5/30 Z</b>	with brad point, D 5 mm, NL 30 mm, GL 53,5 mm, in self-service display pack	21,00 25,20	<b>491066</b>
<b>Dowel drill HW shank 8 mm HW S8 D6/30 Z</b>	with brad point, D 6 mm, NL 30 mm, GL 53,5 mm, in self-service display pack	21,60 25,92	<b>491067</b>
<b>Dowel drill HW shank 8 mm HW S8 D8/30 Z</b>	with brad point, D 8 mm, NL 30 mm, GL 53,5 mm, in self-service display pack	22,65 27,18	<b>491068</b>
<b>Dowel drill HW shank 8 mm HW S8 D10/30 Z</b>	with brad point, D 10 mm, NL 30 mm, GL 53,5 mm, in self-service display pack	25,00 30,00	<b>491069</b>



Hole series system



Edge trimming system

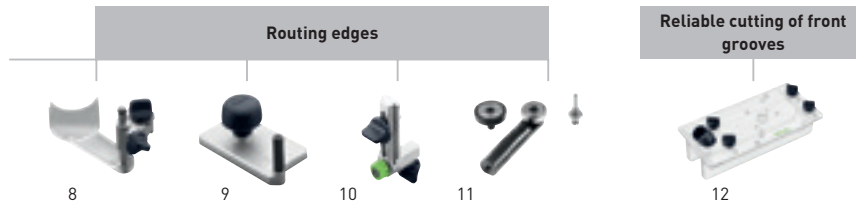

### Accessories for hole series system, edge trimming system

Denomination	Explanation	RRP in £*	Order no.
<b>1 Guide rail FS 1400/2-LR 32</b>	with row of holes, Length 1400 mm, in a carton	86,10 103,32	<b>496939</b>
<b>Guide rail FS 2424/2-LR 32</b>	with row of holes, Length 2424 mm, in a carton	210,05 252,06	<b>491622</b>
<b>2 Stopper LA-LR 32 FS</b>	positions the first hole on the hole series guide rail at a distance of 9.5, 16 or 32 mm from the workpiece edge, qty. in pack 2 piece(s), in self-service display pack	39,75 47,70	<b>496938</b>
<b>3 Hole drilling set LR 32 Set</b>	for routers OF 900, OF 1000, OF 1010, OF 1400 in the FS-LR32 hole drilling system, for use with hole line guide rails, guide plate, centring mandrel, 2 parallel side fence, 2 longitudinal stops, in a carton	173,05 207,66	<b>583290</b>
<b>4 Hole drilling set LR 32-SYS</b>	for OF 900, OF 1000, OF 1010, OF 1400, for use with hole line guide rails, guide plate, centring mandrel, operation tool, hinge location cutter HM Ø 35 mm, dowel drill HW Ø 5 mm (V-shaped tip), dowel drill HM Ø 5 mm (with centring bit and pre-cutter), 2 parallel side fences with adjustable stop, 2 clamps FSZ 120, 2 longitudinal stops, in a SYSTAINER SYS 1 T-LOC	338,90 406,68	<b>584100</b>
<b>5 Parallel side fence SA-LR 32</b>	with adjustable stop, for parallel alignment of guide rails, in a carton	49,20 59,04	<b>485758</b>
<b>6 Adjustable stop AR-LR 32</b>	for OF 900, OF 1000, OF 1010, OF 1400, for parallel side fence, in a carton	24,70 29,64	<b>485759</b>
<b>7 Guide plate FP-LR 32</b>	for routers OF 900, OF 1000, OF 1010, OF 1400 in the FS-LR32 hole drilling system, centring mandrel, in a carton	97,95 117,54	<b>494340</b>
<b>8 Chip guard SF-OF</b>	for OF 900, OF 1000, OF 1010, KF, in self-service display pack	32,45 38,94	<b>486242</b>
<b>9 Edging plate UP-OF</b>	for OF 900, OF 1000, OF 1010, KF, angle arm WA-OF and edging plate UP-OF are needed for the flush trimming of projected edges, in self-service display pack	47,70 57,24	<b>486058</b>
<b>10 Angle arm WA-OF</b>	for OF 900, OF 1000, OF 1010, OF 1400, KF, needed to copy workpieces in conjunction with the copier scanning set KT-OF, in self-service display pack	27,95 33,54	<b>486052</b>
<b>11 Copier scanning set KT-OF</b>	for OF 900, OF 1000, OF 1010, OF 1400, KF, copier scanning set KT-OF and angle arm WA-OF are needed to copy workpieces, in self-service display pack	58,20 69,84	<b>486534</b>
<b>12 Routing aid OF-FH 2200</b>	for OF 900, OF 1000, OF 1010, OF 1400, OF 2000, OF 2200, safe guidance of the router thanks to the movable legs, in a carton	163,55 196,26	<b>495246</b>

## Routing

### System accessories

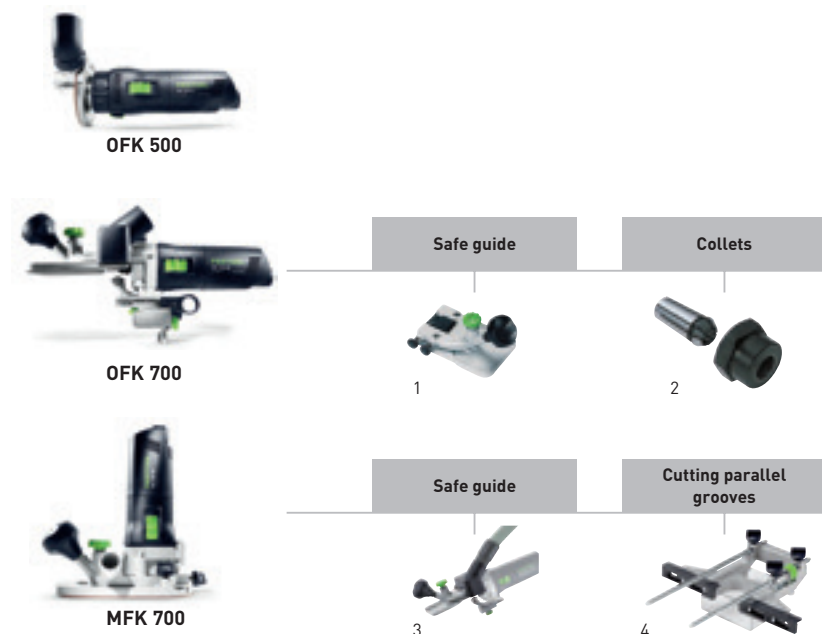

#### Accessories for laminate trimmer OFK 500, OFK 700, module edge router MFK 700

Denomination	Explanation	RRP in £*	Order no.
1 Router table FT 0°	for routing accurate angles, in a carton	77,30 92,76	<b>491427</b>
2 Collet SZ-D 6/OF 1000	for MFK/OFK 700, OF 900, OF 1000, OF 1010, KF, with locking nut, for cutter shank Ø 6 mm, in self-service display pack	34,40 41,28	<b>488760</b>
Collet SZ-D 6,35/OF 1000	for MFK/OFK 700, OF 900, OF 1000, OF 1010, KF, with locking nut, for cutter shank Ø 6.35 mm (1/4"), in self-service display pack	34,40 41,28	<b>488761</b>
Collet SZ-D 8/OF 1000	for MFK/OFK 700, OF 900, OF 1000, OF 1010, KF, with locking nut, for router shank Ø 8 mm, in self-service display pack	34,40 41,28	<b>488755</b>
3 Router table FT-MFK 700 1,5° Set	for MFK 700, 1.5° router table, tarnishing pad, extraction hood, in a carton	108,15 129,78	<b>495165</b>
4 Parallel side fence SA-MFK 700	for MFK 700, with fine adjuster, extraction hood, with 2 guide rods, in a carton	45,45 54,54	<b>495182</b>

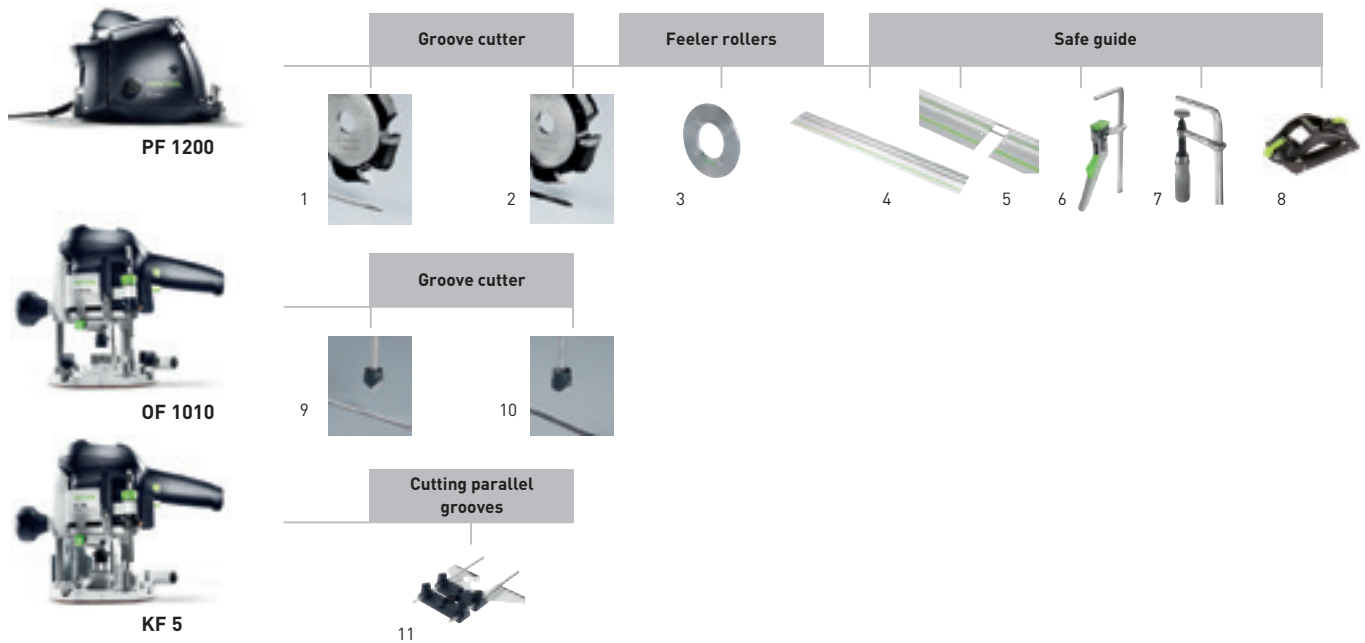

### Accessories for aluminium composite milling machine PF 1200, router OF 1010, putty router KF 5

Denomination	Explanation	RRP in £*	Order no.
1 V-grooving bit HW 118x14-90°/Alu	D 118 mm, alpha 90 °, in self-service display pack	326,30 391,56	491470
2 V-grooving bit HW 118x18-135°/Alu	D 118 mm, alpha 135 °, in self-service display pack	369,05 442,86	491471
3 Feeler roller for aluminium composite panels D2	disc size 2 mm, in self-service display pack	26,35 31,62	491542
Feeler roller for aluminium composite panels D3	disc size 3 mm, in self-service display pack	27,15 32,58	491543
Feeler roller for aluminium composite panels D4	disc size 4 mm, in self-service display pack	27,15 32,58	491544
Feeler roller for aluminium composite panels D6	disc size 6 mm, in self-service display pack	26,35 31,62	491545
Feeler roller for aluminium composite panels A3	disc size 3 mm, in self-service display pack	27,15 32,58	491538
Feeler roller for aluminium composite panels A4	disc size 4 mm, in self-service display pack	27,15 32,58	491539
Feeler roller for aluminium composite panels A6	disc size 6 mm, in self-service display pack	26,35 31,62	491540
4 Guide rail	see chapter Workplace organisation on page 352		
5 Connecting piece FSV	to connect guide rails for long workpieces, qty. in pack 1 piece(s), in self-service display pack	12,60 15,12	482107
6 Lever clamp FS-HZ 160	for MFT, solid steel version, Span 160 mm, in self-service display pack	40,10 48,12	491594
7 Fastening clamp FSZ 120	for MFT, solid steel version, Span 120 mm, qty. in pack 2 piece(s), in self-service display pack	28,80 34,56	489570
Fastening clamp FSZ 300	for MFT, solid steel version, Span 300 mm, qty. in pack 2 piece(s), in self-service display pack	35,75 42,90	489571
8 GECKO DOSH dual suction pad	see chapter Workplace organisation on page 354		
9 V-groove cutter HW shank 8 mm HW S8 D18-90° (Alu)	D 18 mm, NL 8 mm, GL 59 mm, alpha 90 °, in self-service display pack	55,30 66,36	491444
10 V-groove cutter HW shank 8 mm HW S8 D18-135° (Alu)	D 18 mm, NL 3,3 mm, GL 59 mm, alpha 135 °, in self-service display pack	55,30 66,36	491443
11 Fine adjuster for parallel side fence FE-OF 1000/KF	for OF 900, OF 1000, OF 1010, KF, for fast and dimensionally accurate adjustment on the parallel side fence, can be retrofitted, delivered without side stop and guide rods, in self-service display pack	25,00 30,00	483358

## Routing

### Cutters

If you want to achieve guaranteed quality, compromise is out of the question. Festool therefore recommends that you always use original Festool routing accessories for all Festool routers. Manufactured with the same care as the machines themselves from high grade steel and extremely wear-resistant carbide, the tools include cutting blades that boast exceptional micro-grain quality and density. Outstanding cutter geometry means the tools are synonymous with superior durability and superb results.

### The right material for every application

#### HW Tungsten carbide

HW routers are ideally suited to processing hardwood, panel materials and plastic.

#### HS High performance, high speed steel

This steel has mechanical and thermal properties that are best suited for routing soft materials such as spruce and pine.

#### Tip

For the best routing patterns, the cutters should always be mounted at the lowest depth possible, and at least as far as the marking for minimum clamping length on the router shank.

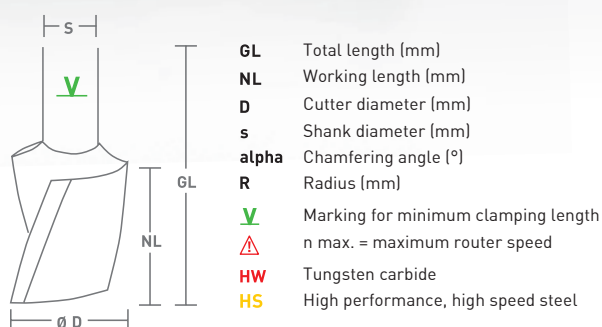

## Groove cutter

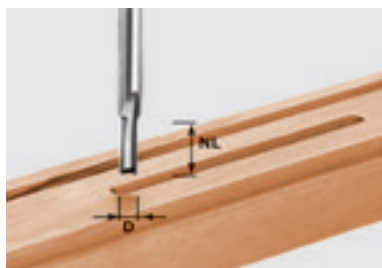

### Router cutter HW, solid hard metal with base blade, shank 8 mm

**HW**  
s = 8

D	NL	GL	RRP in £*	Order no.
3	6	45	26,85 32,22	490952
4	10	45	26,85 32,22	490953
5	12	45	27,35 32,82	490954
6	14	55	28,15 33,78	490955
7	17	55	29,40 35,28	490956
8	20	55	30,35 36,42	490957
8	30	60	34,50 41,40	491647



### Router cutter HW with fitted base blade, shank 8 mm

**HW**  
s = 8

D	NL	GL	RRP in £*	Order no.
9	23	55	25,30 30,36	490958
10	20	60	25,60 30,72	490959
10	25	60	27,75 33,30	490960 **
10	30	60	29,90 35,88	491648
11	20	60	28,25 33,90	490961
12	20	60	28,80 34,56	490962
12	30	60	31,65 37,98	491649
13	20	60	30,35 36,42	490963
14	20	60	30,80 36,96	490964
15	20	60	32,85 39,42	490965
16	20	60	36,15 43,38	490966
16	30	65	36,85 44,22	490967
18	20	60	38,45 46,14	490968
18	30	65	38,80 46,56	490969
19	20	60	39,25 47,10	490970
20	20	60	39,70 47,64	490971
20	30	65	40,65 48,78	490972
22	20	60	42,30 50,76	490973
24	20	60	44,95 53,94	490974
25	20	60	49,65 59,58	490975
30	20	60	55,30 66,36	490976

\*\* for slot jointing with the Festool VS 600, with extra precision in the diameter

### No compromises.

The partially ground standard tungsten carbide blade provides an increased service life when drilling panel materials

### Long service life, even when plunge cutting.

If you wish to achieve quality cutting results with ease when drilling, grooving, rebating and long-hole routing, you are best advised to use the HW groove cutter. It cuts precisely, makes drilling easier and has a long service life.

### Hard-wearing bit

After 60 holes in a kitchen worktop (30 mm depth): bit only shows slight signs of wear



### Worn bit

After 60 holes in a kitchen worktop (30 mm depth): blunt cutter



# Routing

## Cutters

### Groove cutter

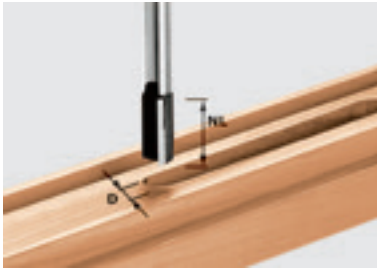

**Router cutter HW with fitted base blade, shank 12 mm**

**HW**  
s = 12

D	NL	GL	RRP in £*	Order no.
10	35	90	49,10 58,92	491086
12	40	90	③ 51,40 61,68	491087
13,2	35	85	① 65,00 78,00	493789
14	40	85	60,65 72,78	491088
14	50	100	77,75 93,30	491089
15	35	85	② 73,05 87,66	493790
16	45	90	62,85 75,42	491090
16	60	100	80,05 96,06	491091
18	45	90	67,40 80,88	491092
20	45	90	④ 70,80 84,96	491093
22	45	90	75,95 91,14	491094
24	45	90	80,05 96,06	491095
30	35	90	107,05 128,46	491096

### HW "Schall-Ex" and "Planet" groove cutter.

The perfect solution when installing automatic door seals on-site.

#### Effective dimensions of seal types

Seal	Width	Depth	Cutter type
Planet HS	13,1	30	①
Schall-Ex L	14,8	32	②
Schall-Ex RD	14,8	28	②
Draft excluders	12	40	③
Double seals	12	40	③
Schall-Ex Ultra	19,7	30	④

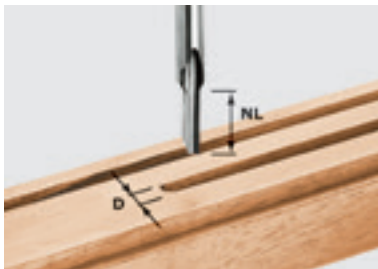

**Router cutter HS single-edged, with base blade, shank 8 mm**

**HS**  
s = 8

D	NL	GL	RRP in £*	Order no.
3	8	45	13,15 15,78	490941
4	15	48	13,15 15,78	490942
5	12	50	13,15 15,78	490943

### Multi-talented.

The HS spiral groove cutter and the HW solid carbide spiral groove cutter: Fast rate of advance for grooving, rebating, long-hole cutting, drilling and copy routing. The chips are drawn upwards by the spiral cutter, keeping the groove permanently clean.

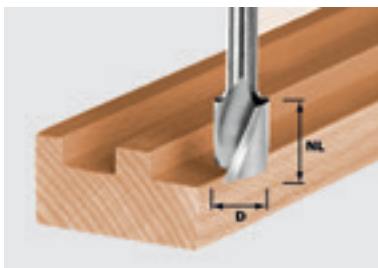

**Spiral router cutter HS with base blade, shank 8 mm**

**HS**  
s = 8

D	NL	GL	RRP in £*	Order no.
6	16	50	21,60 25,92	490944 **
8	19	50	16,80 20,16	490945
10	30	60	25,00 30,00	490946 **
12	20	52	20,40 24,48	490947
14	20	52	22,65 27,18	490948
16	20	52	25,00 30,00	490949
18	25	57	28,80 34,56	490950
20	25	57	31,10 37,32	490951



\*\* for slot jointing with the Festool VS 600, with extra precision in the diameter

**Spiral router cutter HW solid hard metal with base blade, shank 8 mm**

**HW**  
s = 8

D	NL	GL	RRP in £*	Order no.
4	10	45	42,30 50,76	490977
6	21	50	44,65 53,58	490978 **
8	25	55	47,35 56,82	490979
10	30	60	55,30 66,36	490980 **



## Reversible blade rebating cutter



### Turning plate router cutter HW single-edged, with base blade, shank 8 mm

**HW**  
s = 8

D	NL	GL	RRP in £*	Order no.
8	20	50	85,85 103,02	491078
10	25	55	86,95 104,34	491079
12	30	61	89,25 107,10	491080
14	30	66	101,00 121,20	492715
16	30	70	98,45 118,14	492716
18	30	70	104,40 125,28	492717

### Accessories for turning plate router cutter HW, single-edged with base blade, shank 8 mm

<b>Reversible blade HW-WP 30x12x1,5 (4x)</b> for 492716, 492717, 491081, 491120 cutters, main plate	55,30 66,36	491393
<b>Replacement blade for cutter HW-WP 20x4,1x1,1 (4x)</b> for cutter 491078	40,65 48,78	491386
<b>Replacement blade for cutter HW-WP 25x5,5x1,1 (4x)</b> for cutter 491079 (4 pcs)	42,90 51,48	491387
<b>Replacement blade for cutter HW-WP 30x5,5x1,1 (4x)</b> for cutters 491080, 492715	45,15 54,18	491388
<b>Replacement blade for cutter HW-WP 7,6x12x1,5 (4x)</b> pre-cutter for 492716, 492717, 491120 cutters	37,40 44,88	491390

### Its efficiency speaks for itself.

The reversible blades provide consistent cutter dimensions and precision – without resharpening. Quick cutter changes and reversible blade guarantee sharp cutters and greater economic efficiency at all times.

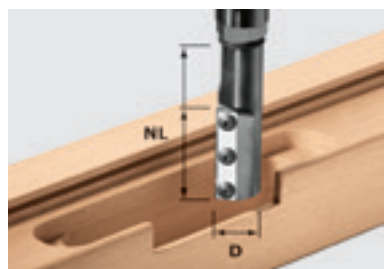

### Turning plate router cutter HW single-edged, with base blade, shank 12 mm

**HW**  
s = 12

D	NL	GL	RRP in £*	Order no.
16	50/60	110	173,50 208,20	497454

### Accessories for turning plate router cutter HW, single-edged with base blade, shank 12 mm

<b>Reversible blades Wepla Set D 16 2+2</b> spare reversible blades set for cutter 497454	38,45 46,14	497458
---	----------------	--------

### For door hinges in block frames and door leaves.

The extra long reversible blade cutter is suitable for extreme routing depths, with direct bit holder for 20 and 24 mm diameters. For precision working in combination with router OF 2200 and extra long copying ring (order no. 497453).



### Turning plate router cutter HW single-edged, with base blade, direct bit holder

**HW**  
**KN**

D	NL	GL	RRP in £*	Order no.
20	50/60	110	184,15 220,98	497455
24	50/80	117	192,50 231,00	497456

### Turning plate rebating cutter set HW single-edged, with base blade, direct bit holder

**HW**  
**KN**

RRP in £*	Order no.
434,85	497457
521,82	

### Accessories for turning plate router cutter HW, single-edged with base blade, direct bit holder

<b>Reversible blade Wepla Set D 20 2+2</b> spare reversible blade set for cutter 497455	42,30 50,76	497568
<b>Reversible blade Wepla Set D 24 2+2</b> spare reversible blades set for cutter 497456	39,60 47,52	497569
<b>Copying ring KR-D 30,0/21,5/OF 2200</b> for OF 2200, extra long safety copying ring D30, 21 mm high, required for use of reversible blade cutters 497455 and 497456, D 30 mm, Ø 27 mm	23,45 28,14	497453



Wepla cutter set [no. 497457] Ø 20 and Ø 24 in a Mini-Systainer, incl. copying ring and tool.

# Routing

## Cutters

### Stepped cutter, ovolo edge cutter, half-round cutter, roundover cutter

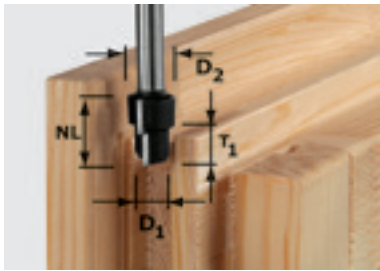

#### Stepped cutter, shank 12 mm

**HW**  
s = 12

D1	D2	NL	T1	RRP in £*	Order no.
16,30	12,30	14	9,30	82,35 98,82	492713
20,30	12,30	14	6	86,75 104,10	492714

#### Perfect combined with the routing aid.

The stepped cutter and the Festool routing aid can be used to rout windows and house doors quickly and precisely, making sure they do not tilt or wobble.

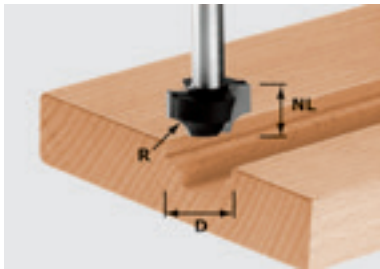

#### Ovolo edge cutter HW, shank 8 mm

**HW**  
s = 8

D	NL	GL	R	RRP in £*	Order no.
17	10	40	3	42,30 50,76	491004
19	11	41	4	42,90 51,48	491005
21	12	42	5	45,15 54,18	491006
23	13	45	6	47,35 56,82	491007
27	15	45	8	49,10 58,92	491008

#### For decorative fronts using imitation panelling.

It is possible to plunge-cut centrally into the front of the furniture using the standard bit.

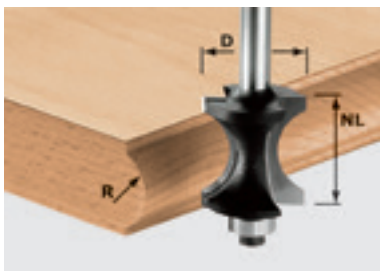

#### Half-round cutter HW with ball bearing guide, shank 8 mm

**HW**  
s = 8

D	NL	GL	R	RRP in £*	Order no.
27	28	70	12	66,45 79,74	491139

#### For the complete job.

For decorative board edging the HW halfround cutter does a great job. It is perfectly designed for 28 mm thick laminated wood board. Its ball bearing guide guides the router directly along the template and ensures that curved parts can also be profiled.

#### Accessories for half-round cutter HW

<b>Ball bearing guide D12,7x4,97x4,76 (2x)</b>	15,30	491383
Diameter 12,7 mm	18,36	



#### Ogee cutter HW with ball bearing guide, shank 8 mm

**HW**  
s = 8

D	NL	GL	R	RRP in £*	Order no.
16,7	9	49	2	45,55 54,66	491009
19,1	10	50	3	46,15 55,38	491010 **
20,7	11	51	4	46,80 56,16	491011 **
22,7	12	52	5	47,35 56,82	491012 **
25,5	13,5	54	6,35	48,45 58,14	491013 **
28,7	15	55	8	50,25 60,30	491014 **
31,7	16,5	56	9,5	52,40 62,88	491015 **
38,1	19	59	12,7	57,45 68,94	491016 **
42,7	22	62	15	60,90 73,08	491017 **

#### One tool – two uses.



With ball bearing guide Ø 12.7 mm for rounding



With ball bearing guide Ø 9.5 mm for beading

#### Ogee cutter HW with ball bearing guide, shank 12 mm

**HW**  
s = 12

D	NL	GL	R	RRP in £*	Order no.
63	32	82	25	112,20 134,64	491107

#### Accessories for classic ogee cutter HW

<b>Ball bearing guide D12,7x4,97x4,76 (2x)</b>	15,30	491383
Diameter 12,7 mm	18,36	
<b>Ball bearing guide D9,53x3,17x4,76 (2x)</b>	27,80	491382
Diameter 9,53 mm	33,36	

\*\* delivered items include Ø 12.7 mm and Ø 9.5 mm ball bearing

## Turning plate slot cutter, chamfer cutter, classic ogee cutter

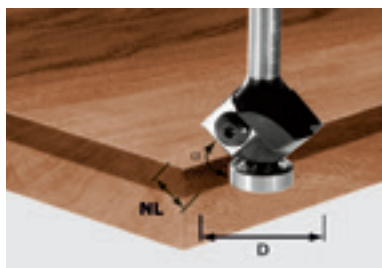

### Turning plate chamfer/edge trimming cutter HW with ball bearing guide, shank 8 mm HW s = 8

D	NL	GL	alpha	RRP in £*	Order no.
27	8	55	45	102,20 122,64	499807

### Accessories for turning plate slot cutter HW

<b>Ball bearing guide D12,7x4,97x4,76 (2x)</b> Diameter 12,7 mm	15,30 18,36	491383
<b>Reversible blade HW-WP 12x12x1,5 (4x)</b>	33,90 40,68	491391



### Chamfer cutter HW with ball bearing guide, shank 8 mm HW s = 8

D	NL	GL	alpha	RRP in £*	Order no.
18	11	50	15	45,50 54,60	499801
25,7	25,1	70	15	47,35 56,82	491132
25	11	50	30	46,50 55,80	499800
38,5	25,7	64	30	55,30 66,36	491133
26	7	48	45	49,25 59,10	499799
36	11,5	53	45	44,05 52,86	491025

### Chamfer cutter HW, shank 12 mm

D	NL	GL	alpha	RRP in £*	Order no.
44	30	80	30	68,55 82,26	491101
55	20	76	45	75,95 91,14	491102

### Accessories for chamfer cutter HW

<b>Ball bearing guide D12,7x4,97x4,76 (2x)</b> Diameter 12,7 mm	15,30 18,36	491383
--	----------------	--------



### Ogee chamfer cutter HW with ball bearing guide, shank 8 mm HW s = 8

D	NL	GL	R	alpha	RRP in £*	Order no.
17,5	19	61	6	15	66,45 79,74	491134
23,1	19	60	6	30	69,85 83,82	491135
31,4	18,5	60	6	45	73,15 87,78	491136

### Accessories for classic ogee/chamfer cutter HW, shank 8 mm

<b>Ball bearing guide D17,5/15° (2x)</b> for cutter 491134, D 17,5 mm, alpha 15 °	40,15 48,18	491403
<b>Ball bearing guide D23,1/30° (2x)</b> for cutter 491135, D 23,1 mm, alpha 30 °	41,10 49,32	491404
<b>Ball bearing guide D31,4/45° (2x)</b> for cutter 491136, D 31,4 mm, alpha 45 °	44,55 53,46	491405

### Precisely calculated.

The edge trimming cutter with HW reversible blades is the ideal tool for those who attach great importance to a long service life, outstanding economic efficiency and constant precision. Purchase one reversible blade, receive the service life of four cutters and save on consequential costs because the cutter can be reversed.

### An unbeatable team.

You can also produce this familiar edge shape commonly found in industry using these shank cutters in a portable router. Here the chamfer cutter and classic ogee cutter with conical ball bearing guide work together perfectly.



# Routing

## Cutters

### Round nose cutter, flute cutter

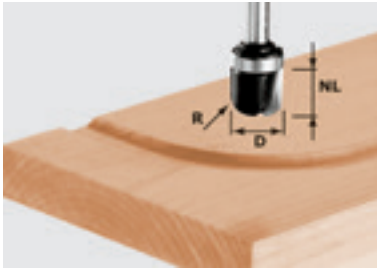

**Water gutter cutter HW with ball bearing guide, shank 8 mm**

**HW**  
s = 8

D	NL	GL	R	RRP in £*	Order no.
19	16	53	6,4	69,85 83,82	490982

#### Accessories for round nose cutter HW

<b>Ball bearing guide</b>	23,75	491396
<b>D 19,05 x 12,7 x 4,97 (2x)</b>	28,50	
Diameter 19,05 mm		

#### Routing without a copying ring.

This cutter can produce curved or round water channels 1:1 without any problem using a template. Time-consuming calculation of curves and distances is no longer necessary.



**Water gutter cutter HW, shank 8 mm**

**HW**  
s = 8

D	NL	GL	R	RRP in £*	Order no.
16	25	65	5	58,50 70,20	490981

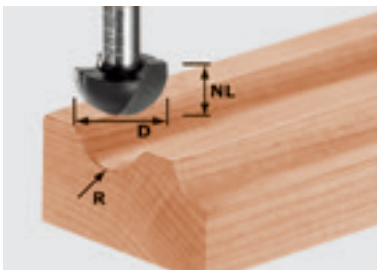

**Flute cutter HW, shank 8 mm**

**HW**  
s = 8

D	NL	GL	R	RRP in £*	Order no.
8	8	38	4	26,20 31,44	490983
12,7	10	40	6,35	29,40 35,28	490984
16	11	41	8	32,85 39,42	490985
19,4	11	41	9,7	35,65 42,78	490986
25,4	14	44	12,7	40,10 48,12	490987

**Flute cutter HW, shank 12 mm**

**HW**  
s = 12

D	NL	GL	R	RRP in £*	Order no.
30	20	60	15	72,05 86,46	491104
40	25	65	20	85,85 103,02	491105



**Flute cutter HW with ball bearing guide, shank 8 mm**

**HW**  
s = 8

D	NL	GL	R	RRP in £*	Order no.
25,5	12,7	54	6,35	40,65 48,78	491018
28,7	14	56	8	44,05 52,86	491019
31,7	14,3	56	9,5	46,15 55,38	491020
38,1	16	57	12,7	52,90 63,48	491021

#### Accessories for flute cutter HW

<b>Ball bearing guide</b>	15,30	491383
<b>D12,7x4,97x4,76 (2x)</b>	18,36	
Diameter 12,7 mm		

## Flush trim cutter, turning plate edge trimming cutter

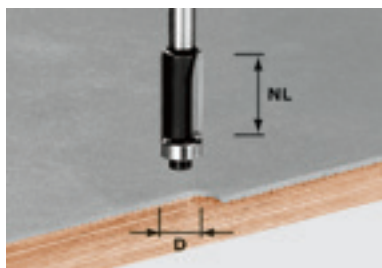

**Edge trimming cutter HW with ball bearing guide, shank 8 mm** **HW**  
**s = 8**

D	NL	GL	alpha	RRP in £*	Order no.
12,7	25	65	0	44,05 52,86	491027

### Accessories for edge trimming cutter HW

<b>Ball bearing guide D12,7x4,97x4,76 (2x)</b>	15,30	491383
Diameter 12,7 mm	18,36	



**Edge trimming cutter HW with ball bearing guide, shank 8 mm** **HW**  
**s = 8**

D	NL	GL	alpha	RRP in £*	Order no.
19,05	25	62	0	46,15 55,38	491028

### Accessories for edge trimming cutter HW

<b>Ball bearing guide</b>	23,75	491396
<b>D 19,05 x 12,7 x 4,97 (2x)</b>	28,50	
Diameter 19,05 mm		

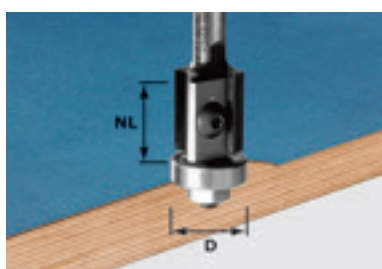

**Turning plate edge trimming cutter HW with ball bearing guide, shank 8 mm** **HW**  
**s = 8**

D	NL	GL	alpha	RRP in £*	Order no.
19	20	64	0	91,45 109,74	491082
19	12	52	0	102,20 122,64	499806

### Accessories for turning plate slot cutter HW

<b>Ball bearing guide D19x6x6 (2x)</b>	22,05	491385
Diameter 19 mm	26,46	
<b>Reversible blade for cutter HW-WP 20x12x1,5 (4x)</b>	33,90 40,68	491392
<b>Reversible blade for cutter HW-WP 12x12x1,5 (4x)</b>	33,90 40,68	491391

### Through thick and thin.

The HW template router is the ideal tool for simple 1:1 copy routing thanks to its large ball bearing guide.



### Precision – even after sharpening.

When sharpening blunt edges on conventional cutters, the diameter aligned to the ball bearing guide normally decreases. This causes a ridge to form when edges are trimmed flush after the bit is sharpened. The turning plate slot cutter and ball bearing guide maintain a high level of precision.

# Routing

## Cutters

### Edge trimming chamfer cutter, drilling cutter, rebating cutter

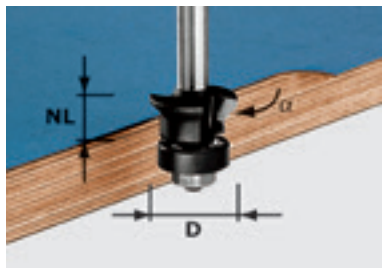

**Chamfer/edge trimming cutter with ball bearing guide, shank 8 mm**

**HW**  
s = 8

D	NL	GL	alpha	RRP in £*	Order no.
24	11	54	0/45	34,40 41,28	491026

#### Accessories for edge trimming chamfer cutter

<b>Ball bearing guide D18 (2x)</b>	35,95	491400
Diameter 18 mm	43,14	

#### One tool – three uses.

Flush trimming of protruding coatings at a right angle, with a 45° chamfer or even both in one working process. The plastic-coated ball bearing guide does not leave any marks and protects the edge of the workpiece.

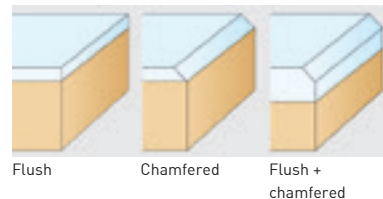

**Drilling cutter HW, shank 8 mm**

D	NL	GL	RRP in £*	Order no.
8	19	65	23,90 28,68	491037

#### Plunge – cut – finished.

The drilling cutter plunges directly into the laminate without requiring pre-drilling and trims the prepared contour flush when guided along the side face.



**Turning plate rebating cutter with ball bearing guide, shank 8 mm**

**HW**  
s = 8

D	NL	GL	RRP in £*	Order no.
38	12	53,7	85,85 103,02	491085 **

#### Accessories for turning plate rebating cutter

<b>Reversible blade HW-WP 12x12x1,5 (4x)</b>	33,90 40,68	491391
<b>Ball bearing guide D9,5/12,7/16/19/22</b>	63,25 75,90	491406
Diameter 9,5; 12,7; 16; 19; 22 mm		

#### Amazingly versatile.

Change ball bearings to rout to 5 different rebate depths with only one basic bit.

\*\* Items included: ball bearing set, Ø 9.5 mm to Ø 22 mm

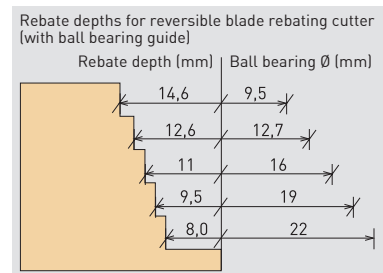

**Rebating cutter HW with ball bearing guide, shank 8 mm**

**HW**  
s = 8

D	NL	GL	RRP in £*	Order no.
31,7	12,7	54	42,30 50,76	491022 ***

#### Accessories for rebating cutter HW

<b>Ball bearing guide D12,7x4,97x4,76 (2x)</b>	15,30 18,36	491383
Diameter 12,7 mm		
<b>Ball bearing guide D9,5/12,7/16/19/22</b>	63,25 75,90	491406
Diameter 9,5; 12,7; 16; 19; 22 mm		

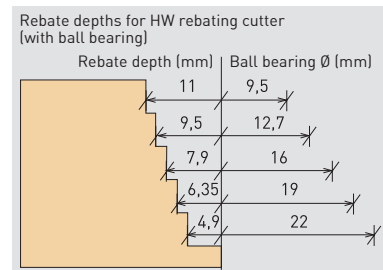

\*\*\* Items included: 1 ball bearing Ø 12.7 mm with 9.5 mm rebate depth

## Dovetail cutter, hand grip/hand rail cutter



### Dovetail cutter with pre-cutter, shank 8 mm

**HW**  
s = 8

D	NL	GL	alpha	RRP in £*	Order no.
14,3	13,5	46	15	38,25 45,90	490990

### Perfect for dovetail joints.

It is possible to produce traditional open and hidden dovetail joints in no time at all using the appropriate router, template and router tool system.



### Dovetail cutters, shank 8 mm

**HW**  
s = 8

D	NL	GL	alpha	RRP in £*	Order no.
13,8	13,5	46	15	32,85 39,42	490992 **
16	13,5	46	15	39,70 47,64	490993
20	17	49	15	37,40 44,88	490996 **
14,3	16	50	10	34,20 41,04	491164 ***
20	26	58	10	39,90 47,88	491165 ***



For use with jointing system VS 600:  
\*\* for partially covered dovetail joint  
\*\*\* for open dovetail joint

<b>HS</b> s = 8					
13,8	13,5	46	15	18,85 22,62	490991 **
20	17	49	15	28,25 33,90	490995 **



### Recessed grip cutter HW with ball bearing guide, shank 8 mm

**HW**  
s = 8

D	NL	GL	R	RRP in £*	Order no.
19	19	68	16	69,85 83,82	491033

### Accessories for hand hole cutter HW

<b>Ball bearing guide</b>	23,75	491396
<b>D 19,05 x 12,7 x 4,97 (2x)</b>	28,50	
Diameter 19,05 mm		

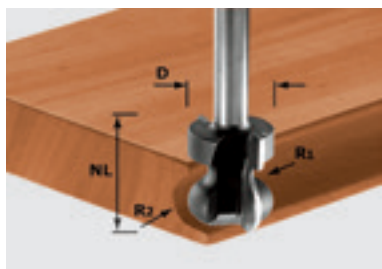

### Hand rail cutter HW, shank 8 mm

**HW**  
s = 8

D	NL	GL	R	RRP in £*	Order no.
22	16	59	2,5/6	65,90 79,08	491140



# Routing

## Cutters

### Tongue and groove cutter, script cutter, V groove cutter



Tongue and groove cutter HW, shank 8 mm					HW s = 8
D	NL	GL	RRP in £*	Order no.	
34	32	62	74,30 89,16	491034	

Setting table for tongue and groove cutters			
Wood thickness (1)	Height, Y dimension (2)	Stop, X dimension (3)	
12	9,2	8,8	
13	9,7	9,3	
14	10,2	9,8	
15	10,7	10,3	
16	11,2	10,8	
17	11,7	11,3	
18	12,2	11,8	
19	12,7	12,3	
20	13,2	12,8	
21	13,7	13,3	

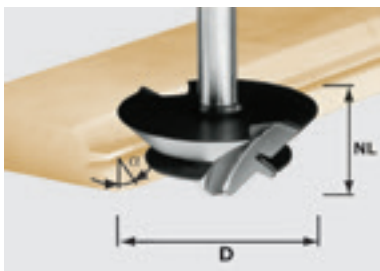

Mitre tongue and groove cutter, shank 12 mm					HW s = 12
D	NL	GL	alpha	RRP in £*	Order no.
64	27	67	45	130,60 156,72	492709



n max. 22,000

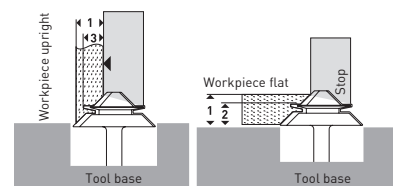

As both workpieces to be glued are to be processed in one cutter setting, the setting of the mitre-tongue and groove cutter requires the precise adjustment of the stop and the table height. The graphic above and the settings table can be used for assistance. Nevertheless, readjustment may be necessary!

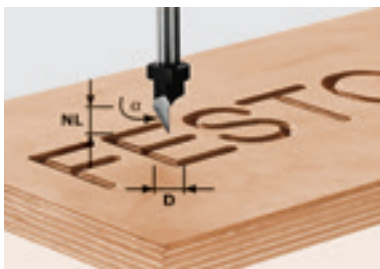

Script cutter, shank 8 mm					HW s = 8
D	NL	GL	alpha	RRP in £*	Order no.
11	9,5	55	60	39,70 47,64	491003

					HS s = 8
D	NL	GL	alpha	RRP in £*	Order no.
11	9,5	55	60	31,65 37,98	491002

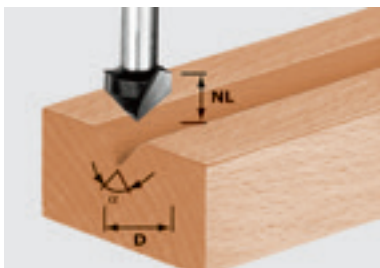

V-groove cutter, shank 8 mm					HW s = 8
D	NL	GL	alpha	RRP in £*	Order no.
14	7	50	90	29,40 35,28	490999

					HS s = 8
D	NL	GL	alpha	RRP in £*	Order no.
11	9,5	50	60	12,60 15,12	490997
14	7	50	90	13,65 16,38	490998

#### Ideal for decorative veining.

The V-groove cutter is the right choice for decorative veining on workpieces with flush joints – e.g. door frames, furniture frame joints and furniture components.



## Disk groove cutter, hinge location cutter

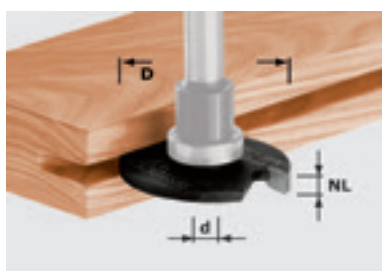

### Groove cutting disc HW

HW  
s = 8

D	Ø	NL	RRP in £*	Order no.
40	6	1,5	17,10 20,52	491038
40	6	1,8	17,50 21,00	491039
40	6	2	17,95 21,54	491040
40	6	2,5	18,45 22,14	491056
40	6	2,8	53,30 63,96	490421
40	6	3	19,15 22,98	491057
40	6	3,5	19,35 23,22	491058
40	6	4	19,70 23,64	491059
40	6	5	20,30 24,36	491060

### Cutter spindle for groove cutting disc HW

D	Ø	NL	GL	BB	RRP in £*	Order no.
14	6	1,5-5	49	-	17,40 20,88	499805
16	6	1,5-5	43	16	22,55 27,06	499803
28	6	1,5-5	45	28	36,00 43,20	499804

### Accessories for cutter spindle, shank 8 mm

<b>Ball bearing guide D16x5x6,35 (2x)</b> Diameter 16 mm	②	26,45 31,74	491384
<b>Ball bearing guide D28x8x10 (2x)</b> Diameter 28 mm	③	29,15 34,98	491397

### Hinge location cutter HW, with HW chip breaker, shank 8 mm

HW  
s = 8

D	GL	RRP in £*	Order no.
15	54,5	39,70 47,64	491070
18	54,5	43,40 52,08	491071
20	54,5	46,15 55,38	491072
25	54,5	52,70 63,24	491073
26	54,5	55,90 67,08	491074
30	54,5	57,35 68,82	491075
34	54,5	58,40 70,08	491076
35	54,5	59,10 70,92	491077

**3 different cutter spindles are available for use of the disk groove cutter from 1.5 mm to 5 mm groove width.**

Cutter spindle 1 has a fixed shaft, which is not suitable as a thrust surface (fire hazard). Therefore, this cutter spindle is only intended for work with a side stop.

Cutter spindle 2 is equipped with a 16 mm ball bearing (above the disk slot), which serves as a thrust surface. With this cutter spindle, a groove depth of 12 mm results from the use of the 40 mm disk slot.

Cutter spindle 3 is equipped with a 28 mm ball bearing (above the disk slot), which serves as a thrust surface. With this cutter spindle, a groove depth of 6 mm results from the use of the 40 mm disk slot.

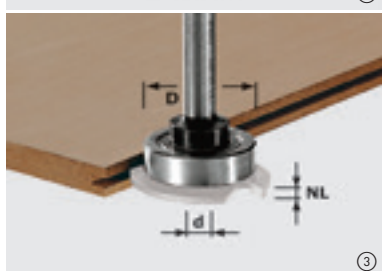

All cutter spindles have a flat for changing the disk groove cutter.

### For sealed doors.

A cutter spindle with ball bearing guide D 28 and disc groove cutter with a width of 4 mm are ideal for routing door seals in door frames.



### Accurate dimensioning with System 32.

The LR 32 hole series system makes routing a row of holes for shelves and false floors amazingly simple. The holes for hinge fittings are also cut accurately between the holes on the System 32 grid.

# Routing

## Cutters

### Dowel/through-hole drill, T-slot cutter, roman ogee cutter, multi profile cutter

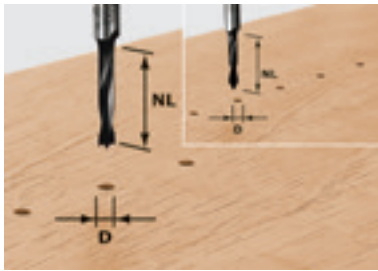

\*\* without centre point

#### Dowel drill HW, shank 8 mm

**HW**  
s = 8

D	NL	GL	RRP in £*	Order no.
3	16	55	31,10 37,32	491065 **
5	30	53,5	21,00 25,20	491066
6	30	53,5	21,60 25,92	491067
8	30	53,5	22,65 27,18	491068
10	30	53,5	25,00 30,00	491069

#### Drill HW, shank 8 mm

**HW**  
s = 8

D	NL	GL	RRP in £*	Order no.
5	30	53,5	25,60 30,72	491064

#### Versatile use.

The dowel drill HW is ideal for drilling rows of holes and combining with the dowel unit from jointing system VS 600.



Through-hole drill

#### Roman ogee cutter HW with ball bearing guide, shank 8 mm

**HW**  
s = 8

D	NL	GL	R1	R2	RRP in £*	Order no.
31,7	13	53	4	4	52,40 62,88	491029
38,1	19	59	6,35	6,35	59,65 71,58	491030

#### Accessories for double radius cutter

<b>Ball bearing guide D12,7x4,97x4,76 (2x)</b>	15,30	491383
Diameter 12,7 mm	18,36	



#### Multi-profile cutter HW with ball bearing guide, shank 8 mm

**HW**  
s = 8

D	NL	GL	R	RRP in £*	Order no.
36,7	21	61	6 / 6	64,30 77,16	491031

#### Accessories for multi-profile cutter

<b>Ball bearing guide D12,7x4,97x4,76 (2x)</b>	15,30	491383
Diameter 12,7 mm	18,36	

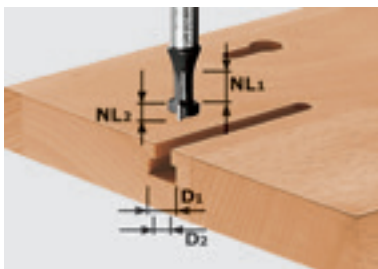

#### Key-hole cutter HW, shank 8 mm

**HW**  
s = 8

D1	D2	UL1	UL2	GL	RRP in £*	Order no.
10,5	6	8	5	50	29,40 35,28	491035

#### Excellent for special tasks.

For cutting T-grooves, shaped holes and keyhole mountings in solid wood and panel material.

## Profile cutter, counterprofile cutter

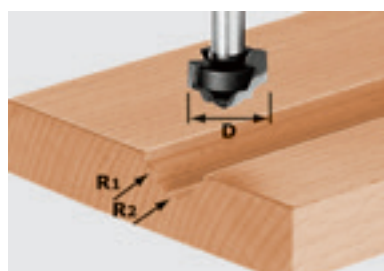

Profile cutter HW, shank 8 mm

**HW**  
s = 8

D	NL	GL	R1	R2	RRP in £*	Order no.
19	12,5	54	4	5	47,35 56,82	491032



Profile cutter HW, shank 8 mm

**HW**  
s = 8

D	NL	GL	R1	R2	RRP in £*	Order no.
42	13	50	6	12	65,45 78,54	491137



Profile cutter radius HW with ball bearing guide, shank 8 mm

**HW**  
s = 8

D	NL	GL	R	RRP in £*	Order no.
42	14	54	6	67,10 80,52	491131

### Simple and exact.

This profile cutter with its long-drawn radius is the ideal power tool for rounding furniture fronts, tabletops, benches or chairs. Curved or round parts can also be rounded easily with this tool.

### Accessories for profile cutters, radius

Ball bearing guide D12,7x4,97x4,76 (2x)	15,30	491383
Diameter 12,7 mm	18,36	



Counterprofile cutter spring HW with ball bearing guide, shank 8 mm

**HW**  
s = 8

D	NL	B	R	RRP in £*	Order no.
43	21	5	16	95,70 114,84	491130

### Framed doors with counterprofile and panelling.

Whether you wish to produce traditional profiles or modern shapes – adjusting the cutting rings is simple with the ball bearing guide.

### Accessories for counterprofile cutter, tongue

Ball bearing guide D16x5x6,35 (2x)	26,45	491384
Diameter 16 mm	31,74	



Counterprofile cutter groove HW with ball bearing guide, shank 8 mm

**HW**  
s = 8

D	NL	B	R	RRP in £*	Order no.
43	21	5	16	95,70 114,84	491129



### Accessories for counterprofile cutter groove HW

Ball bearing guide D16x5x6,35 (2x)	26,45	491384
Diameter 16 mm	31,74	

# Routing

## Cutters

### Profile tongue cutter, profile groove cutter, facing cutter



**Profile/spring cutter HW with ball bearing guide, shank 8 mm** **HW**  
s = 8

D	NL	B	R	RRP in £*	Order no.
46	20	4	22	152,65 183,18	490643

#### For classic furniture fronts.

You can cut classic framed doors in differing styles using these tool sets. The double-edged carbide tools achieve a clean, even routing pattern.



**Profile/groove cutter HW with ball bearing guide, shank 8 mm** **HW**  
s = 8

D	NL	B	R	RRP in £*	Order no.
46	20	4	22	152,65 183,18	490645

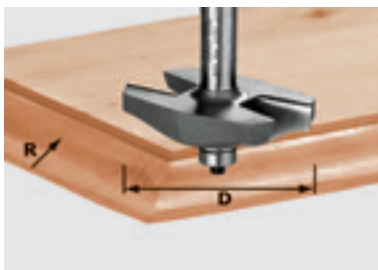

**Plane cutter HW with ball bearing guide, shank 12 mm** **HW**  
s = 12

D	NL	GL	R	RRP in £*	Order no.
67	12	68	19	130,70 156,84	490127

⚠ n max. 22,000



Facing cutter with ball bearing: for cutting classic curved panelling.



**Plane cutter HW with ball bearing guide, shank 8 mm** **HW**  
s = 8

D	NL	GL	R	RRP in £*	Order no.
42,7	13	50	6	63,15 75,78	491138



Facing cutter without ball bearing: for deeper tapers.

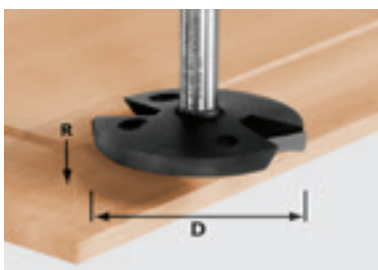

**Facing cutter HW, shank 12 mm** **HW**  
s = 12

D	NL	GL	R	RRP in £*	Order no.
68	14	58	35	125,15 150,18	492712

⚠ n max. 22,000

#### Facing and counterprofiling all in one.

You can use this tool to cut the panelling and the frame and produce complete fronts in combination with a disc groove cutter.



#### Accessories for facing cutters

<b>Ball bearing guide D12,7</b> Diameter 12,7 mm	20,60 24,72	491398
<b>Ball bearing guide D16x8x4,76</b> D 16 mm	25,80 30,96	493062

## Hand rail cutter, aluminium cutter, plasterboard V-groove cutter

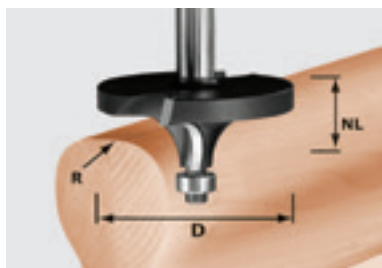

HW hand rail cutter, shank 12 mm

HW  
s = 12

D	NL	R	RRP in £*	Order no.
64	26	16	119,55 143,46	492710

⚠ n max. 22,000

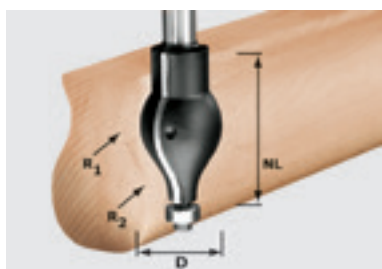

Hand rail cutter HW Profile, shank 12 mm

HW  
s = 12

D	NL	R1	R2	RRP in £*	Order no.
32	57	20	16	112,95 135,54	492711

⚠ n max. 22,000

### Accessories for HW hand rail cutter

Ball bearing guide D12,7x4,97x4,76 (2x)	15,30	491383
Diameter 12,7 mm	18,36	



Aluminium cutter HS, shank 8 mm

HS  
s = 8

D	NL	GL	RRP in £*	Order no.
5	23	65	13,65 16,38	491036



V-groove cutter, shank 8 mm,  
for processing aluminium composite panels

HW  
s = 8

D	NL	GL	alpha	RRP in £*	Order no.
18	3,3	59	135	55,30 66,36	491443
18	8	59	90	55,30 66,36	491444



Cutter V groove HW, shank 8 mm

HW  
s = 8

D	NL	GL	alpha	RRP in £*	Order no.
12,5	14	55	45	39,70 47,64	491000**
32	16	49	90	52,00 62,40	491001

\*\* single-edged tool

### Bench-mounted router TF 2200.

The CMS with OF 2200 router is ideal for cutting workpieces with larger diameters and always provides a secure support surface during routing.



### The aluminium specialist.

The HS aluminium cutter is designed for routing water drainage channels in aluminium profiles up to 2 mm thick.

### Routing aluminium composite panels

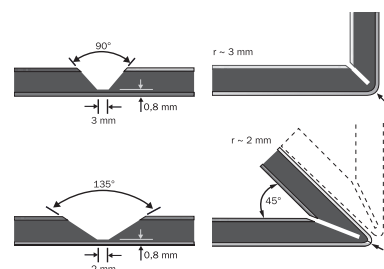

### Routing and jointing instead of gluing and smoothing.

A 45° cutter for rebating 45° corner joints is now available in addition to the 90° plasterboard V-groove cutter.

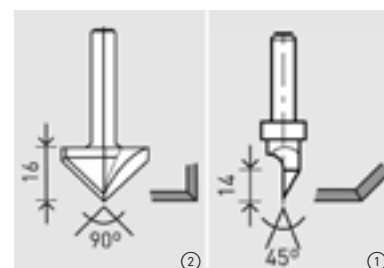

90° plasterboard V-groove cutter (Order no. 491001) 45° plasterboard V-groove cutter (Order no. 491000)

# Routing

## Cutters

### Cutter tools for OFK 700 and MFK 700



Edge trimming cutter HW, shank 8 mm

**HW**  
s = 8

D	NL	GL	RRP in £*	Order no.
19	16	46	36,85 44,22	491666



You can find a comprehensive selection of slot cutters specially designed for routing and cutting slots for edging on page 175. The cutter spindle is required for this application.

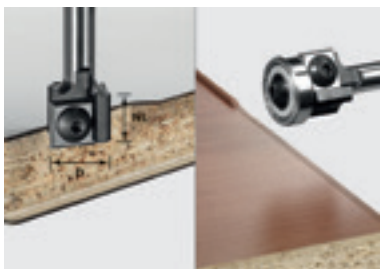

Turning plate edge trimming cutter HW, shank 8 mm

**HW**  
s = 8

D	NL	GL	alpha	qty. in pack	RRP in £*	Order no.
19	12	52	0	1	102,20 122,64	499806

#### Accessories for turning plate edge trimming cutter

Reversible blade HW-WP 12x12x1,5 (4x)	33,90 40,68	491391
Ball bearing guide D19x6x6 (2x) Diameter 19 mm	22,05 26,46	491385

#### Can be used with or without ball bearing.

The recently developed ball bearing attachment system allows you to use trimming cutters with or without a ball bearing guide. Any tool with a ball bearing or external guide system (on the OFK 700, for example) is compatible.



Turning plate chamfer cutter HW, shank 8 mm

**HW**  
s = 8

D	NL	GL	alpha	qty. in pack	RRP in £*	Order no.
27	8	55	45	1	102,20 122,64	499807

#### Accessories for turning plate chamfer cutter HW

Reversible blade HW-WP 12x12x1,5 (4x)	33,90 40,68	491391
Ball bearing guide D12,7x4,97x4,76 (2x) Diameter 12,7 mm	15,30 18,36	491383



Chamfer cutter HW, shank 8 mm

**HW**  
s = 8

D	NL	GL	alpha	qty. in pack	RRP in £*	Order no.
18	11	50	15	1	45,50 54,60	499801
25	11	50	30	1	46,50 55,80	499800
26	7	48	45	1	49,25 59,10	499799

#### Accessories for chamfer cutter HW

Ball bearing guide D12,7x4,97x4,76 (2x) Diameter 12,7 mm	15,30 18,36	491383
---	----------------	--------

## Cutter tools for OFK 700 and MFK 700



### Classic ogee cutter HW, shank 8 mm

**HW**  
s = 8

D	NL	GL	R	qty. in pack	RRP in £*	Order no.
20	2,2	47	2	1	52,45 62,94	499798
22	3,2	48	3	1	53,45 64,14	499797

### Accessories for HW classic ogee cutter

<b>Ball bearing guide D12,7x4,97x4,76 (2x)</b>	15,30	491383
Diameter 12,7 mm	18,36	



Router table 0° for straight routing.  
Order no. 491427.



### Classic ogee cutter HW with reversible blades

**HW**  
s = 8

D	NL	R	GL	RRP in £*	Order no.
28	3	1	55	109,35 131,22	499811
28	3	1,5	55	109,35 131,22	499810
28	3	2	55	109,35 131,22	499809
28	3	3	55	109,35 131,22	499808

### Accessories for classic ogee cutter HW with reversible blades

<b>Replacement cutters</b>	63,25	500369
<b>HW-WP R3 D28 KL12,70FK</b>	75,90	
for Wepla roundover cutters 499808, qty. in pack: 2, reversible blades can be used 4 times, R 3 mm		
<b>Replacement cutters</b>	63,25	500370
<b>HW-WP R2 D28 KL12,70FK</b>	75,90	
for Wepla roundover cutters 499809, qty. in pack: 2, reversible blades can be used 4 times, R 2 mm		
<b>Replacement cutters</b>	63,25	500371
<b>HW-WP R1,5 D28 KL12,70F</b>	75,90	
for Wepla roundover cutters 499810, qty. in pack: 2, reversible blades can be used 4 times, R 1,5 mm		
<b>Replacement cutters</b>	63,25	500372
<b>HW-WP R1 D28 KL12,70FK</b>	75,90	
for Wepla roundover cutters 499811, qty. in pack: 2, reversible blades can be used 4 times, R 1 mm		



Ideal for routing edging: The MFK 700 Basic edge router with spring-loaded ball bearing guide brake and chip deflector, designed specially for machining the most delicate of edging without leaving behind marks.



### Carbide-tipped facing cutter, shank 8 mm, for mod. edge router MFK 700 EQ/B-Plus

**HW**  
s = 8

D	NL	alpha	GL	RRP in £*	Order no.
28	7	15	40	73,80 88,56	500368



# Routing

## Cutters

### Cutter tools for OFK 500 and putty router KF 5

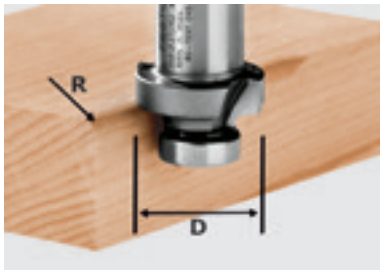

#### Roundover cutter, without ball bearing guide

**HW**  
OFK 500

D	R	RRP in £*	Order no.
27	2	52,80 63,36	490092
27	3	52,80 63,36	490093
27	4	57,35 68,82	490094
27	5	61,80 74,16	490095
27	6	61,80 74,16	490096



Rounding plastic or solid wood veneer.



#### Chamfer cutter, without ball bearing guide

**HW**  
OFK 500

D	alpha	RRP in £*	Order no.
27	60	47,45 56,94	491533
27	45	47,45 56,94	490090
27	30	47,45 56,94	490091



Chamfering plastic or solid wood veneer.

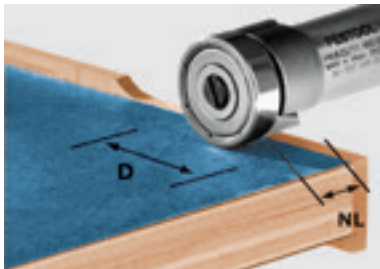

#### Edge trimming cutter, with ball bearing guide

**HW**  
OFK 500

D	NL	RRP in £*	Order no.
22	8	59,30 71,16	490565
22	8	47,45 56,94	490085



Flush trimming of plastic or solid wood veneer.

#### Accessories for cutters OFK 500

<b>Ball bearing guide KLS-D 15,8-OFK</b>	16,65	490249
for cutter 490090, 490091, 490092, 490093, 490094, 490095, 490096, 491533, with clamping screw	19,98	
<b>Ball bearing guide KLS-D22-OFK</b>	18,75	490250
for cutter 490085, with clamping screw	22,50	



## Cutters for putty router KF 5



### Rebate clearing cutter HW, shank 8 mm

**HW**  
s = 8

D	NL	GL	RRP in £*	Order no.
33	15	68	86,60 103,92	483249

### For windows after removal of glazing.

This carbide cutter is ideal for routing windows after the glazing is removed. Available with ball bearing for flush trimming or rebating to different depths.

### Accessories for putty router KF, Spare parts and accessories

<b>Bearing guide KF-05 8/17</b>	17,60	480175
Rebate width 8 mm, Ball bearing guide Ø 17 mm	21,12	
<b>Bearing guide KF-03 9/15</b>	16,65	480173
Rebate width 9 mm, Ball bearing guide Ø 15 mm	19,98	
<b>Bearing guide KF-04 10/13</b>	15,75	480174
Rebate width 10 mm, Ball bearing guide Ø 13 mm	18,90	
<b>Bearing guide KF-07 11/11</b>	19,60	480177
Rebate width 11 mm, Ball bearing guide Ø 11 mm	23,52	
<b>Bearing guide KF-06 12/9</b>	19,60	480176
Rebate width 12 mm, Ball bearing guide Ø 9 mm	23,52	
<b>Rebating cutter KF-S3</b>	78,85	434690
replacement cutter for 482057	94,62	



### Putty cutter HW, with fixed ball bearing at the top

D	NL	GL	RRP in £*	Order no.
30	21	68	130,20 156,24	482057

# Routing

## Cutters

### Specialised cutters for solid surface and mineral materials

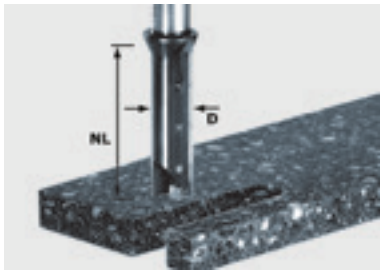

\*\* also suitable for use with OF 2200 and worktop template APS 900

#### Reversible blade groove cutter HW, shank 12 mm **HW** s = 12

D	NL	GL	RRP in £*	Order no.
14	45	105	171,30 205,56	491110 **

#### Accessories for turning plate groove cutter

Reversible blade HM-WP 50x5,4x1,1 (4x)	77,65 93,18	491389
--	----------------	--------

#### Extremely resistant to breaking and very efficient.

Solid carbide spiral groove cutters are manufactured from cylindrical rods of carbide specially developed for machining mineral materials and particularly resistant to breaking.

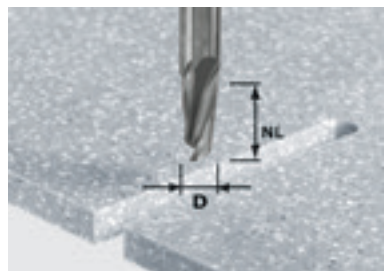

#### Spiral groove cutter, TC **HW** s = 10, 12

D	NL	GL	RRP in £*	Order no.
10	27	70	75,75 90,90	492653
12	27	70	83,40 100,08	492654
12	42	87	106,65 127,98	492655

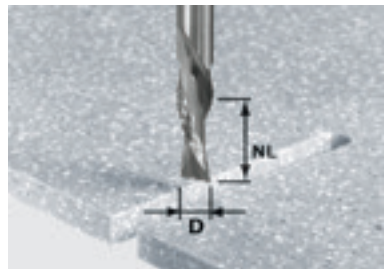

#### Spiral groove cutter with roughing and finishing, TC, shank 12 mm **HW** s = 12

D	NL	GL	RRP in £*	Order no.
12	42	87	120,70 144,84	492656

#### For fast working progress.

Solid carbide cutters specially designed for routing cut-outs for basins, for example.

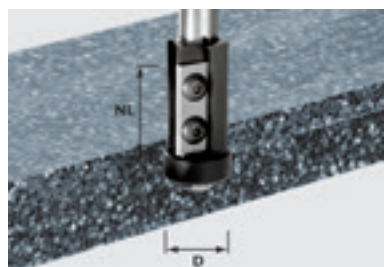

#### Turning plate edge trimming cutter HW with ball bearing guide, shank 12 mm **HW** s = 12

D	NL	GL	RRP in £*	Order no.
21	30	89	118,50 142,20	491120

#### Accessories for turning plate edge trimming cutter

Reversible blade HW-WP 30x12x1,5 (4x) for 492716, 492717, 491120 cutters, main plate	55,30 66,36	491393
Ball bearing guide D21-15,88 (2x) Diameter 21 mm	55,00 66,00	491408

#### Precise and durable.

Mineral materials are very demanding on the cutting blade. When working with the ball bearing guide, it is absolutely vital that the cutter and ball bearing guide are permanently aligned. This is why tools with reversible blades pay dividends within a very short time.



## Specialised cutters for solid surface and mineral materials

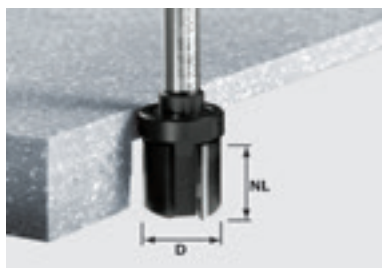

<b>Edge trimming cutter with ball bearing, top, shank 12 mm</b>				<b>HW</b> s = 12
D	NL	RRP in £*	Order no.	
28	25	81,25 97,50	492705	

### Accessories for edge trimming cutter with roller bearing at the top

<b>Ball bearing guide D28x8,3x15</b>	34,20	493063
Diameter 28 mm	41,04	

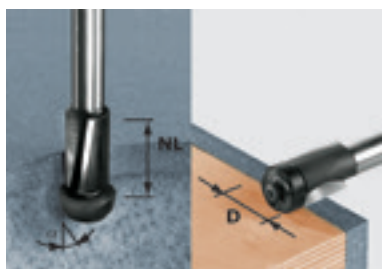

both replacement ball bearing guides included in delivery

<b>Edge trimming cutter with ball bearing, bottom, shank 12 mm</b>				<b>HW</b> s = 12
D	NL	RRP in £*	Order no.	
19	25	72,55 87,06	492661	

### Accessories for edge trimming cutter with ball bearing, bottom

<b>Ball bearing guide D19x8x4,76</b>	26,10	493055
Diameter 19 mm	31,32	
<b>Ball bearing guide D22x8x4,76/11°</b>	30,05	493056
Diameter 22 mm	36,06	

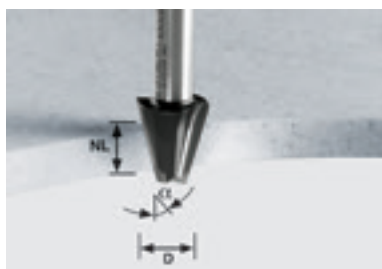

<b>Chamfer cutter HW</b>					<b>HW</b> s = 12
D	NL	alpha	RRP in £*	Order no.	
23	25	15	70,40 84,48	492663	



<b>Chamfer cutter, TC, with ball bearing, top, shank 12 mm</b>					<b>HW</b> s = 12
D	NL	alpha	RRP in £*	Order no.	
28	25	15	80,15 96,18	492703	

### Accessories for HW chamfer cutter with roller bearing at the top

<b>Ball bearing guide D28x8,3x15</b>	34,20	493063
Diameter 28 mm	41,04	

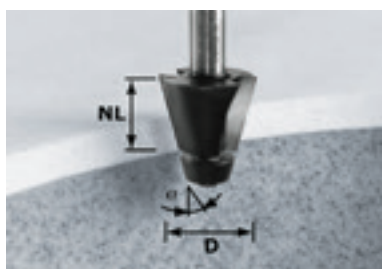

<b>Chamfer cutter HW with ball bearing guide, shank 12 mm</b>					<b>HW</b> s = 12
D	NL	alpha	RRP in £*	Order no.	
33,54	25	15	72,55 87,06	492665	

### Accessories for chamfer cutter with ball bearing guide

<b>Ball bearing guide D18,5x8x4,76/15°</b>	28,85	493057
Diameter 18,50 mm	34,62	

### Two tools in one.

Cutting inlays flush or routing overhangs on fitted basins at an angle of 11°. Both are possible simply by changing the ball bearing guide included in the delivery.



### Chamfer cutter with cutting bit

When cutting, the router is guided along the template by a copying ring. The cutting edge allows the cutter to plunge to full depth and finish the basin cut-out in a single operation.

### Chamfer cutter with ball bearing guide.

When cutting, the router is guided along the top of the template by the ball bearing. The tool can be used in any router without the need of a copying ring.

# Routing

## Cutters

### Specialised cutters for solid surface and mineral materials

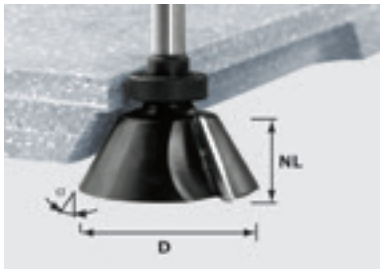

#### Chamfer cutter, TC, with undercut, shank 12 mm

**HW**  
s = 12

D	NL	alpha	RRP in £*	Order no.
66	28	30	120,70 144,84	492667

n max. 16,000

#### Accessories for chamfer cutter HW

<b>Ball bearing guide D28x8,3x15</b>	34,20	493063
Diameter 28 mm	41,04	

#### The perfect duo for modern counters.

Chamfer cutter undercut: the first step is to cut a chamfer. Benefit: the counter does not have to be turned over.

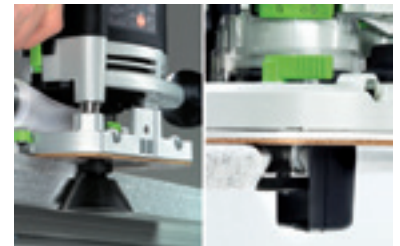

#### Ogee chamfer cutter HW with ball bearing guide, shank 12 mm

**HW**  
s = 12

D	NL	R	alpha	RRP in £*	Order no.
39,5	23	6,35	30	104,40 125,28	492707

#### Accessories for HW classic ogee cutter

<b>Ball bearing guide D39,5x8x4,76/30°</b>	35,65	493064
Diameter 39,50 mm	42,78	

The classic ogee cutter then adds a curve to the chamfer. The system was designed for 2 or 3 rebated boards with a thickness of 12.7 mm.

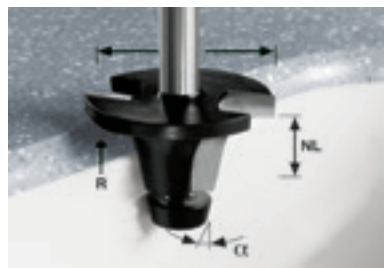

#### Reservoir cutter HW with ball bearing guide, shank 12 mm

**HW**  
s = 12

D	NL	R	alpha	RRP in £*	Order no.
53	25	6,35	18	107,55 129,06	492669
49	25	6,35	12	107,55 129,06	492670
45	25	6,35	6	107,55 129,06	492671
63	25	12,70	18	141,60 169,92	492675
59	25	12,70	12	141,60 169,92	492676
56	25	12,70	6	141,60 169,92	492677

n max. 22,000

#### Accessories for reservoir cutter

<b>Ball bearing guide D18,8x8x4,76/18°</b>	28,85	493059
for router 18°, Diameter 18,80 mm	34,62	
<b>Ball bearing guide D20x8x4,76/12°</b>	31,35	493060
for router 12°, Diameter 20 mm	37,62	
<b>Ball bearing guide D21,1x4,76/6°</b>	29,95	493061
for router 6°, Diameter 21,10 mm	35,94	

#### Simply ingenious.



Adjustable axial ball bearing guide on the basin cutter

If the cutting blade is not aligned with the ball bearing guide exactly after sharpening, the join to the cutter blade can be re-adjusted by moving the axial ball bearing guide, extending the service life of your Festool basin cutters even longer.

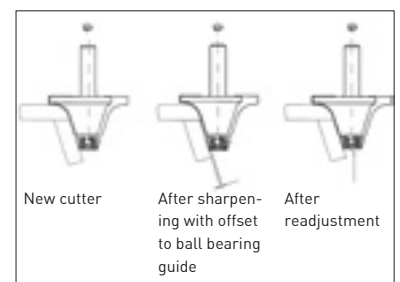

## Specialised cutters for solid surface and mineral materials



**Ogee cutter HW with ball bearing guide, shank 12 mm**

**HW**  
s = 12

D	NL	R	RRP in £*	Order no.
22	10	3	63,75 76,50	492681
26	12	5	68,20 81,84	492682
28,8	13,4	6,35	69,15 82,98	492683
32	15	8	71,35 85,62	492684
41,40	19	12,7	74,70 89,64	492685
54	25	19	92,20 110,64	492686
△ 66,80	31,40	25,4	119,55 143,46	492687

△ n max. 22,000

### Accessories for classic ogee cutter HW

<b>Ball bearing guide D12,7x4,97x4,76 (2x)</b> Diameter 12,7 mm	15,30 18,36	491383
<b>Ball bearing guide D9,53x3,17x4,76 (2x)</b> Diameter 9,53 mm	27,80 33,36	491382

### A full range.

Roundover cutters with radius of 3 mm to 25.4 mm – with this range, you can meet virtually any demand your customers may have.



03



**Ogee cutter, undercut, TC, with ball bearing, shank 12 mm**

**HW**  
s = 12

D	NL	R	RRP in £*	Order no.
44,70	13	6,35	97,75 117,30	492695
△ 57,40	20	12,70	123,90 148,68	492696
△ 70	25	19	145,95 175,14	492697

△ n max. 22,000

### Accessories for HW classic ogee cutter, undercut

<b>Ball bearing guide D28x8,3x15</b> Diameter 28 mm	34,20 41,04	493063
--	----------------	--------



**Carbide-tipped facing cutter, shank 12 mm**

**HW**  
s = 12

D	NL	R	RRP in £*	Order no.
52	7,30	1,50	81,25 97,50	492701

### To suit any task.

Flat protruding edges, e.g. pilaster strip inserts, can be trimmed flush without any problem using the plane cutter.

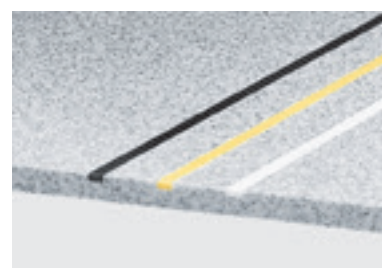





## Planing

**Overview of products and applications** 190

**One handed planer** EHL 65 EQ 192

**Planer** HL 850 193

**Accessories and consumable materials** 194

The Festool system

# Planing

## Overview of products and applications

Page 192 ————— 193

Whether lightweight and handy for assembly tasks or a large rebate depth for an unlimited range of applications – both planers have one thing in common: excellent results.

**EHL 65 EQ**

**HL 850**

**Hand-held planer**  
for wooden structures  
Next page 338



### Applications

### Electric planers

#### Rebating

Door and window rebates up to 23 mm

Unlimited rebate depth

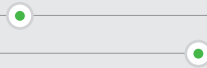

#### Strip material, edges, beams, planks, flat surfaces

Trimming work (strip material, edges, board material)

Planing beams, planks and broad surfaces

Proximate planing

Texturing wooden surfaces



#### Precise results

Drawing cut for clean surfaces

Trimming and planing precise angles

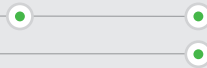

#### Operation and handling

One-handed operation

Suitable for stationary operation

Dust extraction connector on either side

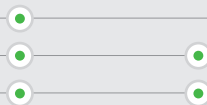

#### Technical data

	EHL 65 EQ	HL 850
Power consumption (W)	720	850
Rotational speed (rpm)	15600	11000
Planing width (mm)	65	82
Planing depth (mm)	0-4	0-3,5
Max. rebate depth (mm)	23	∞
Connection Ø d/e (mm)	27	36
Weight (kg)	2,4	3,9

Extremely appropriate

Appropriate



### The principle of the one-handed planer is exemplary.

Carpenters still regard the classic hand planer as the machine to use for demanding surfaces. With a drawing cut and perfect adjustment of the blade angle,



we have adopted and transferred this principle to the unique spiral blade.



### Noticeably more refined, considerably quieter.

The spiral blade is diagonal instead of horizontal and makes a drawing cut that reduces machine noise considerably and produces a much more refined planing pattern. No chatter marks. No reworking.



### Simply faster.

The simple blade replacement system with automatic adjustment function eliminates the need to adjust the blade cutting circle diameter.

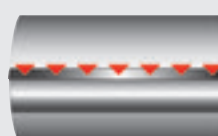

#### Operating principle: classic planer blade

The blade meets the wood head-on, resulting in a "chopping cut" that leaves behind chatter marks and splinters. The high forces exerted on the drive shaft also increase tool wear.

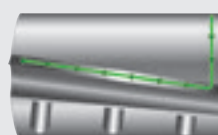

#### Operating principle: spiral blade

Initial contact is made over a small surface and force is then transferred smoothly across the entire width of the blade. The angled blade strips off the wood more gently and decreases tool wear.

## Planing

One-handed planer EHL 65 EQ

# EHL 65 EQ



### Modified slightly. Improved decisively.

- ▶ Only 2.4 kg, compact height, soft grip on handle and chip depth adjustment, additional grips for better support
- ▶ Quiet: The spiral blade reduces the noise level considerably
- ▶ Maximum 4 mm planing depth and 23 mm rebate depth for more speed and flexibility
- ▶ Infinitely variable chip depth adjustment and spiral blade for high surface quality in diverse application areas

#### Technical data

Power consumption (W)	720
Rotational speed (min <sup>-1</sup> )	15600
Planing width (mm)	65
Planing depth (mm)	0-4
Max. rebate depth (mm)	23
Connection Ø d/e (mm)	27
weight (kg)	2,4



= with electronics

Items Included	RRP in £*	Order no.
parallel side fence, operation tool, in a SYSTAINER SYS 2 T-LOC		
<b>EHL 65 EQ GB 240V</b>	243,00 291,60	<b>574560</b>
<b>EHL 65 EQ GB 110V</b>	243,00 291,60	<b>574561</b>

### Unique results.

The EHL 65 EQ operates with a drawing cut to produce a particularly fine planing pattern. No chatter marks. No rework.

\* Recommended retail price of manufacturer. Dealer prices may vary.  
Excl. VAT.  
Incl. VAT.

#### System accessories from page 196

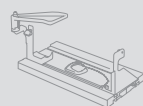

HL 850



**Planer with no limits.**

- ▶ Unlimited rebate depth – single-bearing planing head allows you to work right up to the edge and rebate to unlimited depths
- ▶ Precision chamfering – with 90° V groove in the planer foot
- ▶ Precision – stepless cutting depth
- ▶ Bench unit for greater precision when rebating and trimming

**Technical data**

Power consumption (W)	850
Rotational speed (min <sup>-1</sup> )	11000
Planing width (mm)	82
Planing depth (mm)	0-3,5
Connection Ø d/e (mm)	36
weight (kg)	3,9
Max. rebate depth (mm)	∞



■ = with electronics

Items Included	RRP in £*	Order no.
parallel side fence, rebate depth stop, extraction adapter, operation tool, in a SYSTAINER SYS 3 T-LOC		
<b>HL 850 EB-Plus GB 240V</b>	430,00 516,00	<b>574555</b>
<b>HL 850 E-Plus GB 110V</b>	430,00 516,00	<b>574552</b>

\* Recommended retail price of manufacturer. Dealer prices may vary.  
Excl. VAT.  
Incl. VAT.

**System accessories**  
from page 196

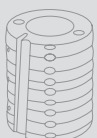

04



**Texturing surfaces.**

Individual rustic planer heads for creating textured surfaces – replaced with a single hand movement.

### The Festool system.

Because things work better when everything fits together: rebating, trimming and texturing of skirting, trim, door rebates, beams or planks. Always with unique results. An entire system consisting of planer heads, stationary units and angle stops complements the integral planer program.

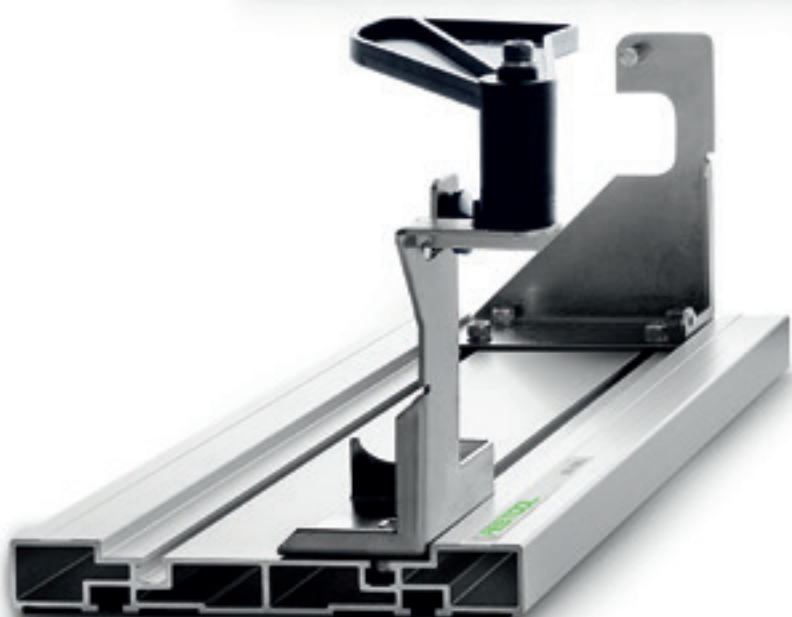
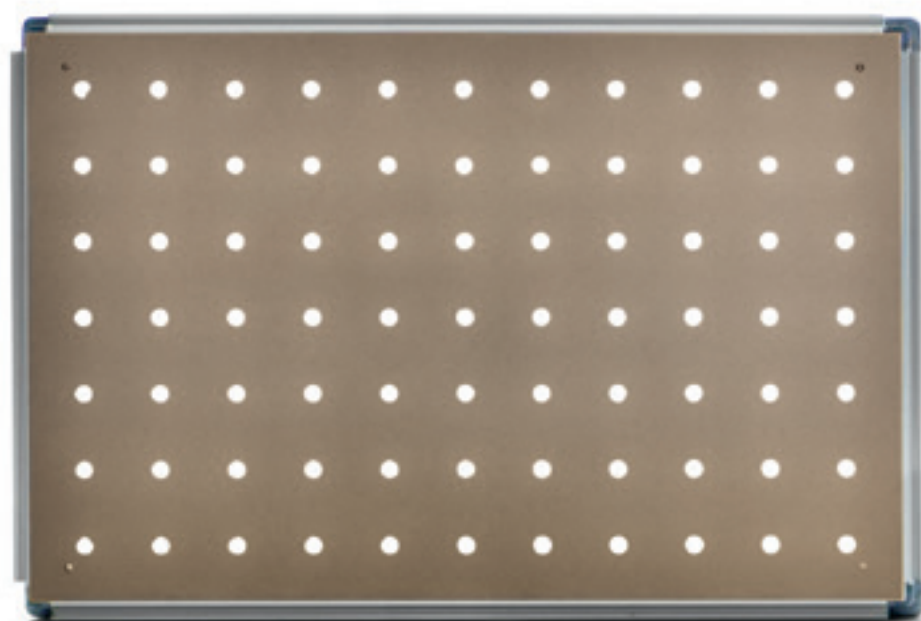

## Planing

Accessories and consumable materials



# Planing

## System accessories

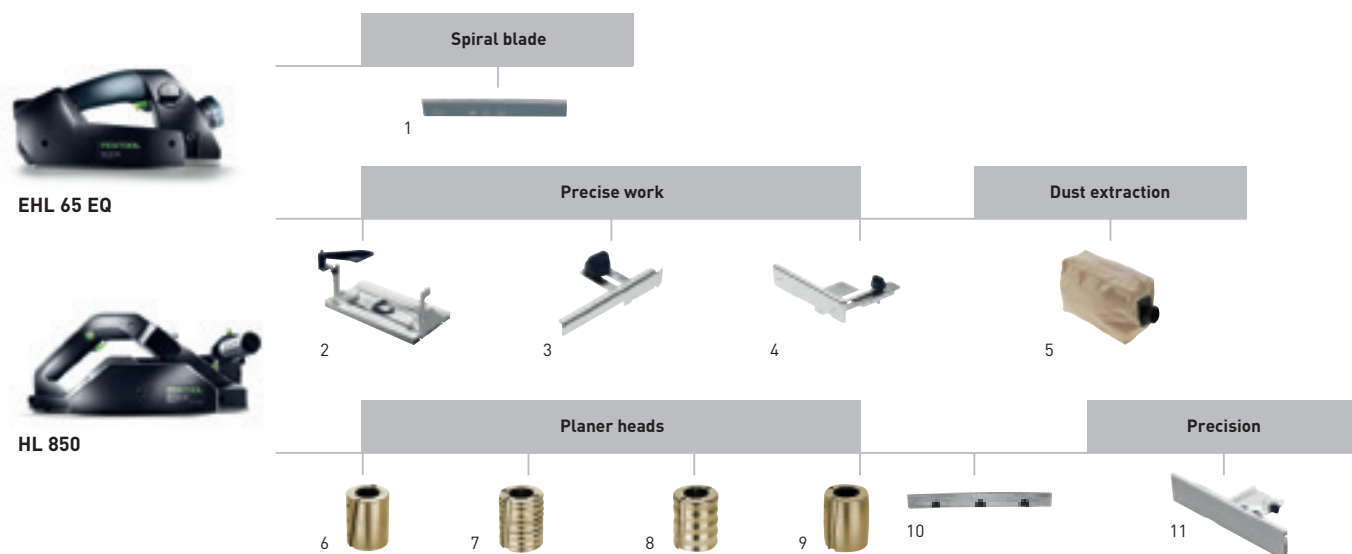

### Accessories for one-handed planer EHL 65, planer HL 850

Denomination	Explanation	RRP in £*	Order no.
<b>1 Spiral blade HW 65</b>	for EHL 65, HW standard planer blades with 65 mm width, HW version for the EHL 65, in self-service display pack	12,80 15,36	<b>488503</b>
<b>2 Bench unit SE-EHL</b>	for EHL 65, for bench-mounted trimming and rebating, swivelling protective cover, slotted assembly board with non-slip coating, including cutting depth scale, in a carton	51,90 62,28	<b>488524</b>
<b>Bench unit SE-HL</b>	for HL 850, for bench-mounted trimming and rebating, swivelling protective cover, slotted assembly board with non-slip coating, including cutting depth scale, in a carton	72,45 86,94	<b>485017</b>
<b>3 Rebate depth stop FA-EHL</b>	for EHL 65, for rebate depths of 0-23 mm, in self-service display pack	6,00 7,20	<b>488543</b>
<b>Rebate depth stop FA-HL</b>	for HL 850, for rebate depths of 0-30 mm, in self-service display pack	8,10 9,72	<b>484512</b>
<b>4 Parallel side fence PA-EHL</b>	for EHL 65, for side guidance, adjustable from 0-82 mm, in self-service display pack	11,80 14,16	<b>488544</b>
<b>Parallel side fence PA-HL</b>	for HL 850, for side guidance, adjustable from 0-82 mm, in self-service display pack	15,20 18,24	<b>484513</b>
<b>5 Chip collection bag SB-EHL</b>	for EHL 65, in a carton	29,40 35,28	<b>488566</b>
<b>Chip collection bag SB-HL</b>	for HL 850, without suction adapter, in a carton	44,75 53,70	<b>484509</b>
<b>Extraction adapter AD-HL</b>	for HL 850, for chip collection bag and suction hose with bushing, suction hose diameter 36 mm, in self-service display pack	11,80 14,16	<b>484507</b>
<b>6 Planing head HK 82 SD</b>	standard design, with HW carbide-tipped spiral blade HW 82 SD, in self-service display pack	107,15 128,58	<b>484520</b>
<b>7 Planing head HK 82 RF</b>	rustic design, fine, with spiral blade HS 82 RF, depth limiter, in self-service display pack	124,95 149,94	<b>484521</b>
<b>8 Planing head HK 82 RG</b>	for HL 850, rustic design, coarse, with HS spiral blade HS 82 RG, depth limiter, in self-service display pack	124,95 149,94	<b>484522</b>
<b>9 Planing head HK 82 RW</b>	for HL 850, rustic design, undulating, with HS spiral blade HS 82 RW, depth limiter, in self-service display pack	124,95 149,94	<b>485331</b>
<b>10 Spiral blade HW 82 SD</b>	for planer head HK 82 SD, HW standard planer blades with 82 mm width, HM standard design, in self-service display pack	20,50 24,60	<b>484515</b>
<b>Spiral blade HS 82 RF</b>	for planer head HK 82 RF, HSS rustic design, fine, in self-service display pack	24,85 29,82	<b>484518</b>
<b>Spiral blade HS 82 RG</b>	for planer head HK 82 RG, HSS rustic design, coarse, in self-service display pack	24,85 29,82	<b>484519</b>
<b>Spiral blade HS 82 RW</b>	for planer head HK 82 RW, HSS rustic design, undulating, in self-service display pack	24,85 29,82	<b>485332</b>
<b>11 Angle stop WA-HL</b>	for HL 850 EB, for planing at angles of 0-45°, can also be used as stop for bench unit SE-HL, stop area length x height 350 x 75 mm, in a carton	67,80 81,36	<b>485018</b>

### Narrow, wide or rustic waves.

Narrow, wide or rustic waves. Replacing the planing head for textured planing requires a single hand movement. Achieving attractive, living wooden surfaces could not be easier.

Narrow

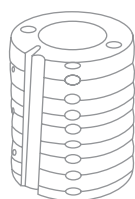

Wide

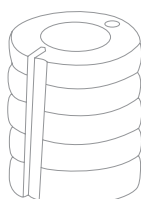

Rustic

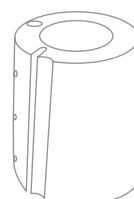

Special planer heads for individually textured wooden surfaces.







## Drilling and screwdriving

<b>Overview of products and applications</b>	200
<b>Cordless drills</b> CXS, C 15, T 15+3, T 18+3	203
<b>Cordless hammer drill</b> BHC 18	206
<b>Cordless drills QUADRIVE, cordless impact drills QUADRIVE</b> DRC 18/4, PDC 18/4	207
<b>Drills QUADRILL, impact drills QUADRILL</b> DR 18/4, PD 20/4	208
<b>Drill QUADRILL</b> DR 20	209
<b>Cordless drywall screwdriver DURADRIVE</b> DWC 18-2500, DWC 18-4500	210
<b>Accessories and consumable materials</b>	212
The Festool system	

# Drilling and screwdriving

## Overview of products and applications

Power or precision, compact or durable, high torque or high speed: the task determines the requirements, Festool cordless drills provide the answers.

Page 203 — 204 — 205 — 205 — 206

CXS

C 15

T 15+3

T 18+3

BHC 18



### Applications

#### Cordless drill

#### Cordless hammer drill

#### Screwdriving in wood, max. diameter

3x15	●	○	○		
4x35	●	●	●	○	○
5x40	●	●	●	●	○
6x80	○	●	●	●	

#### Screwdriving in wood, max. diameter

6x120		●	●	●	
8x220		○	○	○	
8x300					
10x300					
12x300					

#### Drilling in wood, max. diameter

8	●	○	○	○	
15	○	●	●	●	
35		●	●	●	
45		○	○	●	
50					
80					

Drilling in stone (max. Ø drilling in stone)					18 mm
Drilling in concrete (max. Ø drilling in concrete)					18 mm
Drywall screwdriving – Wooden substructure (max. screw Ø 4.2 mm)					
Drywall screwdriving – Sheet metal substructure (max. screw Ø 4.2 mm)		○	○	○	

### Technical data

Battery voltage [V] / capacity li-ion [Ah]	10,8 / 1,5	14,4 / 5,2	14,4 / 5,2	18 / 5,2	18 / 5,2
Power consumption (W)					
Idling speed, 1st gear/2nd gear (rpm)	0-400/0-1200	0-450/0-1500	0-450/0-1500	0-450/0-1500	0-1100/-
Idling speed, 3rd/4th gear (min. rpm)					
Max. torque, wood/steel (Nm)	10/16	25/40	27/40	30/45	10/25
Drilling diameter, wood/steel/stone	12/8/-	35/16/-	35/16	45/16	25/13/18
Chuck range (mm)	1-8	1,5-13	1,5-13	1,5-13	
Tool reception	CENTROTEC	CENTROTEC	CENTROTEC	CENTROTEC	SDS-Plus
Weight (kg)	0,9	1,6	1,5	1,7	2,6

# Drilling and screwdriving

## Overview of products and applications



**Cordless drills QUADRIVE**    **Cordless impact drill QUADRIVE**    **Drill QUADRILL**    **Impact drill QUADRILL**    **Drill QUADRILL**    **Cordless drywall screwdrivers DURADRIVE**

05

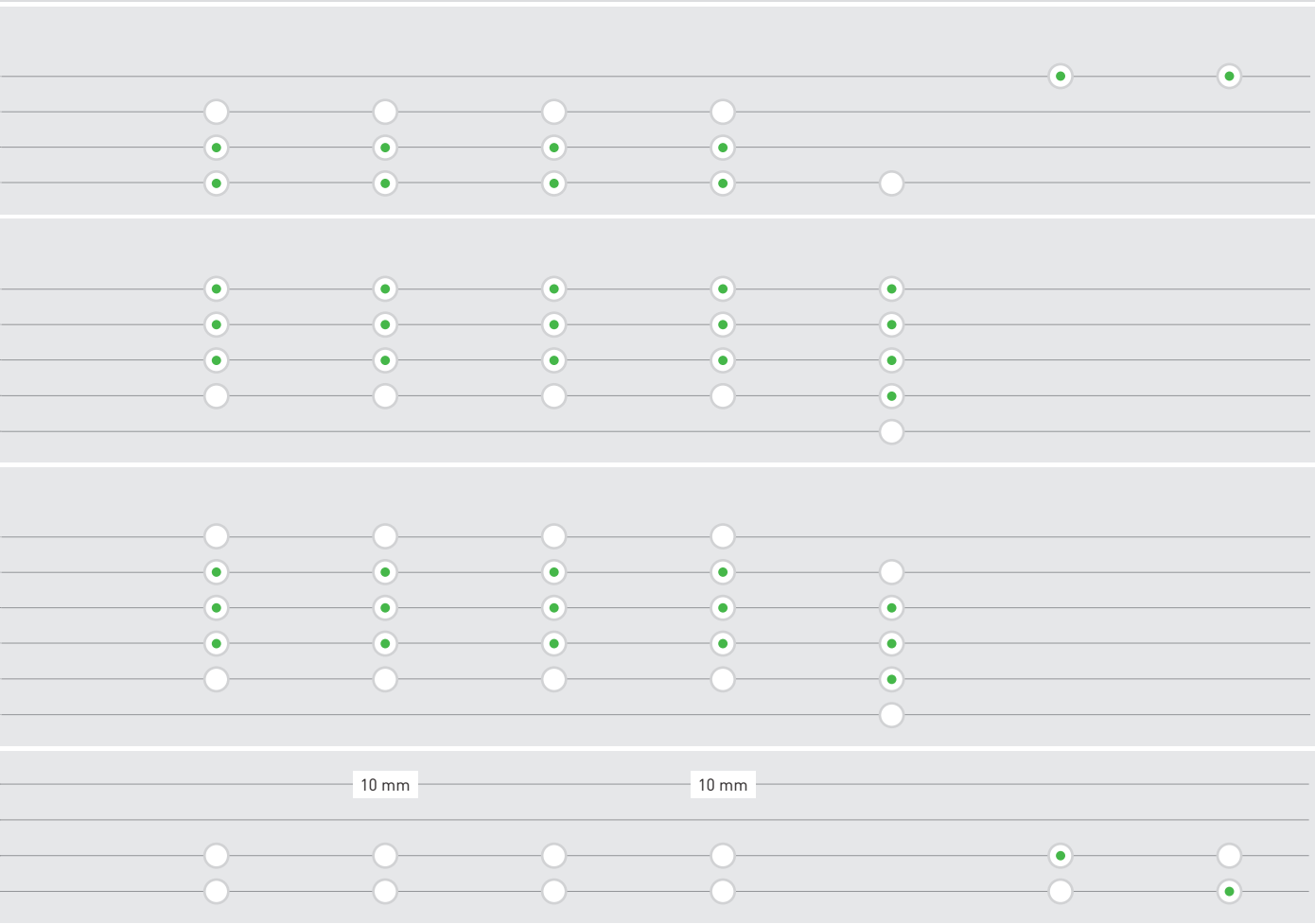

Extremely appropriate     Appropriate

	18 / 5,2	18 / 5,2	705	705	1100	18 / 5,2	18 / 5,2
	0-400/0-850	0-400/0-850	0-400/0-850	0-400/0-850	0-650	0-2500	0-4500
	0-1850/0-3800	0-1850/0-3800	0-1900/0-4000	0-1900/0-4000			
	40/60	40/60	30/50	30/50	98	7/18	5/14
	50/12/-	50/12/10	50/18/-	50/18/20	65/20/28		
	1,5-13	1,5-13	1,5-13	1,5-13	3-16		
	CENTROTEC	CENTROTEC	CENTROTEC	CENTROTEC	CENTROTEC XL	1/4	1/4
	1,8	1,9	1,7	1,8	3,4	2,1	2,1

Vibration and emissions values can be found in the operating manual at [www.festool.co.uk/vibration](http://www.festool.co.uk/vibration)

## Drilling and screwdriving

**Decidedly different:  
Cordless drills by Festool.**



### **More time working, less time charging.**

The EC-TEC drive concept stands for the extraordinary application of power with minimal power consumption across the entire speed range – from the insertion of large screws to drilling at speeds of up to 1500 rpm. The EC-TEC motor is wear-free, has no carbon brushes and is therefore maintenance-free and extremely robust.



### **Simply faster.**

Drilling, countersinking and screwdriving: the CENTROTEC quick-change system is a chuck and bit holder in one, 50% smaller and 80% lighter than a standard drill chuck. The hexagonal tools are centred by ball bearings – for optimised power transmission and 10 times greater true-running precision.



### **A tool that works without needing tools.**

Mounted and quickly replaced without the need for tools: The cordless drills or the powerful QUADRILL mains-operated drill can be retrofitted to 5 tools in an instant using the FastFix attachments: drill, screwdriver, elbow drill, elbow screwdriver or a drywall screwdriver.



# Drilling and screwdriving

## Cordless drill CXS



# CXS



### When it comes to performance, size really isn't that important.

- ▶ Impressive ergonomics and low weight (0.9 kg) for convenient drilling and fastening
- ▶ FastFix interface and CENTROTEC quick tool-change system
- ▶ 12 torque settings and torque switch-off for precision fastening
- ▶ Latest Lithium-ion battery technology for the longest sustained usage

#### Technical data

Battery voltage (V)	10,8
Gears	2
Idling speed, 1st gear/2nd gear (min <sup>-1</sup> )	0-400/0-1200
Drilling diameter, wood/steel	12/8
Torque adjustment (Nm)	0,3-3,4
Max. torque, wood/steel (Nm)	10/16
Chuck range (mm)	1-8
Li-Ion battery capacity (Ah)	2,6
Charging time Li Ion (min)	40
Weight with Li Ion (kg)	0,9



☐ = with electronics

Items Included	RRP in £*	Order no.
charger MXC, elbow adapter CXS, CENTROTEC tool chuck, CENTROTEC bit holder, FastFix keyless chuck 8 mm, bit PZ 2, spare battery pack BP-XS, in a SYSTAINER SYS 1 T-LOC		
<b>CXS Li 2,6 Set GB</b>	224,00 268,80	<b>564533</b>

\* Recommended retail price of manufacturer. Dealer prices may vary.  
Excl. VAT.  
Incl. VAT.

#### System accessories from page 215



#### Screwdriver and drill bits from page 218



#### Watch the product video



### Real power package.

The CXS can overcome any challenge with 10.8 volts. 12 available torque settings for controlled power.

# Drilling and screwdriving

## Cordless drill C 15



product  
design  
award

2010

Brushless EC-TEC motor for a long service life and a high level of efficiency



# C 15



### Distinctive stirrup shape.

Having won many awards for outstanding design, our cordless drills are available with a completely new drive concept. The combination of lithium-ion battery packs and EC-TEC motor make the C 15 even more lightweight, durable and powerful – the C series has reached new heights.

### The perfect shape.

- ▶ Modern EC-TEC motor technology – designed precisely for the requirements of a high-performance cordless drill
- ▶ Fully electronic torque adjustment and cut-out for maximum power utilisation in all working situations
- ▶ The CENTROTEC quick-change system and the FastFix attachments accelerate the work processes
- ▶ Switch easily from fastening to drilling without changing the torque setting

#### Technical data

Battery voltage (V)	14,4
Gears	2
Idling speed, 1st gear/2nd gear (min <sup>-1</sup> )	0-450/0-1500
Drilling diameter, wood/steel	35/16
Torque adjustment (Nm)	0,5-8/0,5-6
Max. torque, wood/steel (Nm)	25/40
Chuck range (mm)	1,5-13
Li-Ion battery capacity (Ah)	5,2
Charging time Li Ion (min)	90
Weight with Li Ion (kg)	1,6



= with electronics

#### Items Included

TCL 3 charger, CENTROTEC tool chuck, CENTROTEC bit holder, FastFix keyless chuck 13 mm, bit PZ 2, spare battery pack lithium-ion 5.2 Ah, 49 x 98 x 71 yellow plastic container, 98 x 147 x 71 green plastic container, in a SYSTAINER SYS 2 T-LOC

#### C 15 Li 5,2-Plus GB 240V

RRP in £\*

Order no.

357,00  
428,40

564553

#### C 15 Li 5,2-Set GB 240V

FastFix angle attachment, FastFix eccentric attachment

438,00  
525,60

564556

\* Recommended retail price of manufacturer. Dealer prices may vary.  
Excl. VAT.  
Incl. VAT.

#### System accessories from page 214



#### Screwdriver and drill bits from page 218



## Drilling and screwdriving

### Cordless drills T 15+3, T 18+3



Brushless EC-TEC motor for a long service life and a high level of efficiency



# T 15+3 / T 18+3



### The power pack that delivers.

- ▶ Ideal ergonomics: compact, lightweight and perfectly balanced
- ▶ Brushless EC-TEC motor with integrated motor management for an extended service life and maximum power
- ▶ Fast change between applications with the CENTROTEC quick-change system and FastFix attachments; all bits can also be inserted into the direct bit holder
- ▶ Switch easily from fastening to drilling without changing the torque setting

Technical data	T 15+3 LI 5,2	T 18+3 LI 5,2
Battery voltage (V)	14,4	18
Gears	2	2
Idling speed, 1st gear/2nd gear (min <sup>-1</sup> )	0-450/0-1500	0-450/0-1500
Drilling diameter, wood/steel	35/16	45/16
Torque adjustment (Nm)	0,5-8/0,5-6	0,5-8/0,5-6
Max. torque, wood/steel (Nm)	27/40	30/45
Chuck range (mm)	1,5-13	1,5-13
Li-Ion battery capacity (Ah)	5,2	5,2
Charging time Li Ion (min)	90	90
Weight with Li Ion (kg)	1,5	1,7



☐ = with electronics

Items Included	RRP in £*	Order no.
TCL 3 charger, CENTROTEC tool chuck, CENTROTEC bit holder, FastFix keyless chuck 13 mm, bit PZ 2, spare battery pack lithium-ion 5.2 Ah, 49 x 98 x 71 yellow plastic container, 98 x 147 x 71 green plastic container, in a SYSTAINER SYS 2 T-LOC		
<b>T 15+3 Li 5,2-Plus GB 240V</b>	357,00 428,40	<b>564560</b>
<b>T 15+3 Li 5,2-Set GB 240V</b> FastFix angle attachment, FastFix eccentric attachment	438,00 525,60	<b>564563</b>
<b>T 18+3 Li 5,2-Plus GB 240V</b>	383,00 459,60	<b>564569</b>
<b>T 18+3 Li 5,2-Set GB 240V</b> FastFix angle attachment, FastFix eccentric attachment	463,00 555,60	<b>564572</b>

\* Recommended retail price of manufacturer. Dealer prices may vary.  
Excl. VAT.  
Incl. VAT.

#### System accessories from page 214

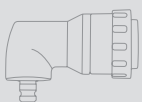

#### Screwdriver and drill bits from page 218



### Brains meet brawn.

15 volt, 18 volt – it's time to break with conventional thinking. With the cordless drills of the T+3-series, which no longer move in a volt class, but rather in a class completely redefined by the interaction of power and intelligence. With fully electronic torque setting and shutdown. And changeover from screwdriving to drilling, without having to adjust the set torque.

## Drilling and screwdriving

### Cordless hammer drill BHC 18

Brushless EC-TEC motor for a long service life and a high level of efficiency



## BHC 18



### Handy and compact – no compromises!

Thanks to its excellent ergonomic design, compact C shape and balanced weight distribution, the BHC 18 becomes the ideal partner for continuous applications. Weighing only 2.6 kg without an additional hand grip, it is considered the lightest tool in its class, which makes overhead work considerably easier. As a fixing hammer with a pneumatic stop, it is ideally suited for drilling dowels in concrete up to 18 mm. The impact function can be switched off for drilling tiles.



### The most powerful compact hammer drill

- ▶ Unbeatable power to weight ratio thanks to the combination of EC-TEC motor
- ▶ Vibration damping for effortless work; maximum working comfort in all work situations
- ▶ Brushless EC-TEC motor with integrated motor management for long service life and the highest output
- ▶ High-quality lithium-ion battery technology for the longest sustained usage

#### Technical data

Battery voltage (V)	18
Gears	1
Idle engine speed (min <sup>-1</sup> )	0-1100
Max. number of strokes (min <sup>-1</sup> )	4895
Drilling Ø (beton) (mm)	18
Crown borer Ø (mm)	68
Single impact energy (J [EPTA])	1,8
Dimensions (L x W x H) (mm)	280 x 88 x 237
Li-Ion battery capacity (Ah)	5,2
Charging time Li Ion (min)	90
Weight with Li Ion (kg)	2,6



= with electronics

Items Included	RRP in £*	Order no.
TCL 3 charger, spare battery pack lithium-ion 5.2 Ah incl. rubberised frame, additional side-mounted hand grip, depth stop, in a SYSTAINER SYS 2 T-LOC		
<b>BHC 18 Li 5,2 GB 240V</b>	454,00 544,80	<b>564589</b>

\* Recommended retail price of manufacturer. Dealer prices may vary.  
Excl. VAT.  
Incl. VAT.

#### System accessories from page 215



#### Hammer drills from page 222





## Drilling and screwdriving

Cordless drills QUADRIVE DRC 18/4  
and cordless impact drills QUADRIVE PDC 18/4



Brushless EC-TEC motor for  
a long service life and a high  
level of efficiency

# QUADRIVE DRC 18/4 / PDC 18/4



05



### The compact tool with impressive rotary power.

- ▶ Brushless EC-TEC motor combined with high-quality lithium-ion battery technology for up to 100% greater fastening capacity and longer service life
- ▶ 4-speed gearbox capable of 3800 rpm for rapid, clean drilling results
- ▶ Universal solution for fastening operations that require high torque and for drilling large diameter holes
- ▶ Axial impact feature (PDC) that can be deactivated for drilling in brickwork

Technical data	DRC 18/4 Li 5,2-Plus	PDC 18/4 Li 5,2-Plus
Battery voltage [V]	18	18
Gears	4	4
Idling speed, 1st gear/2nd gear (min <sup>-1</sup> )	0-400/0-850	0-400/0-850
Idling speed, 3rd/4th gear (min <sup>-1</sup> )	0-1850/0-3800	0-1850/0-3800
Max. torque, wood/steel (Nm)	40/60	40/60
Max. number of strokes (min <sup>-1</sup> )		76000
Drilling Ø (wood/steel) (mm)	50/12	50/12
Drilling Ø in brickwork (mm)		10
Weight with Li Ion (kg)	1,8	1,9
Chuck range (mm)	1,5-13	1,5-13
Li-Ion battery capacity (Ah)	5,2	5,2



■ = with electronics

Items Included	RRP in £*	Order no.
TCL 3 charger, CENTROTEC tool chuck, CENTROTEC bit holder, bit PZ 2, FastFix keyless chuck 13 mm, additional side-mounted hand grip, spare battery pack lithium-ion 5.2 Ah incl. rubberised frame, in a SYSTAINER SYS 2 DF T-LOC		
<b>DRC 18/4 Li 5,2-Plus GB 240V</b>	431,00 517,20	<b>564585</b>
<b>DRC 18/4 Li 5,2-Set GB 240V</b> angle chuck	522,00 626,40	<b>564586</b>
<b>PDC 18/4 Li 5,2-Plus GB 240V</b>	440,00 528,00	<b>564580</b>
<b>PDC 18/4 Li 5,2-Set GB 240V</b> angle chuck	531,00 637,20	<b>564581</b>

\* Recommended retail price of manufacturer. Dealer prices may vary.  
Excl. VAT.  
Incl. VAT.

#### System accessories from page 216



#### Screwdriver and drill bits from page 218



### Intelligent diversity.

Thanks to the FastFix interface the QUADRIVE DRC and PDC can be converted from drill to elbow drill and from drill to screwdriver to elbow screwdriver without using any tools. With the 4-speed transmission the speed and the power can be ideally adapted to all work situations, from powerful screwdriving in 1st gear to drilling at 3,800 rpm in 4th gear. With the PDC an axial impact can be switched on turning the QUADRIVE into a cordless impact drill.

## Drilling and screwdriving

Drill QUADRILL DR 18/4 and  
impact drill QUADRILL PD 20/4

Brushless EC-TEC motor for  
a long service life and a high  
level of efficiency



# QUADRILL DR 18/4 / PD 20/4



### One for all.

- ▶ Five machines in one thanks to the FastFix interface: drill, impact screwdriver, angle drill, angle screwdriver and screwdriver
- ▶ Universal application with 4-speed transmission and speed levels from 400 to 4000 rpm
- ▶ No run-down: The machine brakes immediately after the accelerator trigger is released
- ▶ Extremely manageable weighing only 1.7 kg and up to 10 cm shorter than traditional machines

Technical data	DR 18/4 E FFP-Plus	PD 20/4 E FFP-Plus
Power consumption (W)	705	705
Gears	4	4
Idling speed, 1st gear/2nd gear (min <sup>-1</sup> )	0-400/0-850	0-400/0-850
Idling speed, 3rd/4th gear (min <sup>-1</sup> )	0-1900/0-4000	0-1900/0-4000
Max. torque, wood/steel (Nm)	30/50	30/50
Max. number of strokes (min <sup>-1</sup> )		79000
Drilling Ø (wood/steel) (mm)	50/18	
weight (kg)	1,7	1,8
Drilling Ø (wood/steel/stone) (mm)		50/18/20

### Unbelievably versatile.

Makes your work easier! Because before where many machines were used, for example, to drill in narrow places, fasten large or small screws or screw to a defined depth, today only one machine is required – the QUADRILL DR 18/4 E or PD 20/4 E, also with impact function.

Items Included	RRP in £*	Order no.
CENTROTEC tool chuck, CENTROTEC bit holder, Keyless chuck, additional side-mounted hand grip, in a SYSTAINER SYS 2 DF T-LOC		
<b>DR 18/4 E FFP-Plus GB</b> TX 40	279,00 334,80	<b>769198</b>
<b>DR 18/4 E FFP-Set GB</b> TX 40, angle chuck	375,00 450,00	<b>769199</b>
<b>PD 20/4 E FFP-Plus GB</b> Bits	289,00 346,80	<b>769202</b>
<b>PD 20/4 E FFP-Set GB</b> Bits, angle chuck	384,00 460,80	<b>769203</b>

\* Recommended retail price of manufacturer. Dealer prices may vary.  
Excl. VAT.  
Incl. VAT.

System accessories  
from page 216



Screwdriver and drill bits  
from page 218





# QUADRILL DR 20

### The high-torque drill.

- ▶ Multiple reduction gears that achieve a high torque
- ▶ Removable keyless chuck and bit holder in spindle, perfect for drilling and screwdriving
- ▶ Extremely robust and durable with large attachment collar, heavy-duty drive spindle and large spindle bearing
- ▶ Precision keyed chuck with FastFix and locking device



05



#### Technical data

Power consumption (W)	1100
Gears	1
Idle engine speed (min <sup>-1</sup> )	0-650
Drilling Ø (steel/Al/wood) (mm)	20/28/65
Torque max. (Nm)	98
Chuck clamping range (mm)	3-16
Chuck interface	FastFix
Collar Ø (mm)	57
weight (kg)	3,4
Weight (without chuck) (kg)	2,7



☐ = with electronics

This product is not available in Great Britain.

### The large QUADRILL with excellent speed.

The key feature of the QUADRILL DR 20 E is the FastFix interface with which the machine can be set to different functions in an instant.

System accessories  
from page 216



## Drilling and screwdriving

### Cordless drywall screwdriver DURADRIVE DWC 18

Brushless EC-TEC motor for a long service life and a high level of efficiency



# DURADRIVE DWC 18



### Raises the standard to a very high level.

Nothing measures up to the DURADRIVE in terms of durability and endurance. The driving force behind it is the EC-TEC motor with electronic start/stop function – long life and huge efficiency guaranteed. DURADRIVE is equipped with numerous special features. The start/stop function is particularly innovative: The motor will run only when you are drilling or screwdriving and you don't even have to activate the main switch. One-handed operation for overhead work becomes a piece of cake. With the depth stop, the DWC can also be used for single screws.

### Power and durability for interior work.

- ▶ Precision, wear-free electronic switch-off function for accurate insertion depths and a long service life
- ▶ Energy-saving function for machine start/stop without actuating the main switch
- ▶ Robust, brushless EC motor for maximum efficiency and durability
- ▶ Lightweight and perfectly balanced for non-tiring work

Technical data	DWC 18-2500	DWC 18-4500
	5,2 Li	5,2 Li
Battery voltage (V)	18	18
Gears	1	1
Idle engine speed (min <sup>-1</sup> )	0-2500	0-4500
Max. torque, wood/steel (Nm)	7/18	5/14
Tool reception	1/4"	1/4"
Li-Ion battery capacity (Ah)	5,2	5,2
Weight with depth stop (kg)	1,9	1,9
Weight with magazine attachment (kg)	2,1	2,1



= with electronics

Items Included	RRP in £*	Order no.
TCL 3 charger, magazine attachment, depth stop, belt clip, scaffolding holder, magnetic bit holder, 2 bit PH2, long, spare battery pack lithium-ion 5.2 Ah incl. rubberised frame, in a SYSTAINER SYS 2 T-LOC		
<b>DWC 18-2500 5,2 Li-Plus GB 240V</b>	476,00 571,20	<b>564591</b>
<b>DWC 18-4500 5,2 Li-Plus GB 240V</b>	476,00 571,20	<b>564593</b>

\* Recommended retail price of manufacturer. Dealer prices may vary.  
Excl. VAT.  
Incl. VAT.

### System accessories from page 217



**The Festool battery and charging system.  
Measured power for more charge cycles**

Festool battery packs can be recharged again and again. Steady, gentle charging with an individually adapted charging current as well as a constantly monitored cell temperature and current charging state extend the service life of the cells.

**Robust, compact and ingenious.**

The new TCL 3 charger with state of charge indicator charges rapidly and preserves the battery. In addition to a compact design, the charger also comes with a practical cord holder with wall mounting option. It is also extremely robust due to the fully encapsulated electronics and enclosed housing. The continuous temperature control and undervoltage shutdown protect the battery pack.



**Always informed.**

The capacity indicator always displays the current battery charging state. The system batteries for the C and T series are compatible with all cordless machines from the same voltage class.



**Clever solution.**

With the belt clip the machine can be hooked on to the belt. A rubberised frame can be mounted to protect against impacts.



**Highest flexibility and economy:  
Battery packs in same voltage class can be used**

Cordless machines	Li-ion battery packs				
	10.8 V		14.4 V		18 V
	BP-XS (1.5 Ah)	Standard (3.0 Ah)	Compact (1.5 Ah)	Standard (5.2 Ah)	Standard (5.2 Ah)
DRC/PDC 18					●
DWC 18					●
T 18+3					●
BHC 18					●
PSC/PSBC 420 (18 V)*					●
PSC/PSBC 420 (14,4 V)*				●	
T 15+3				●	
C 15				●	
CXS	●				
<b>Battery charger</b>					
TCL 3		●	●	●	●
MXC	●				

\* Pendulum jigsaws      ● Some items included

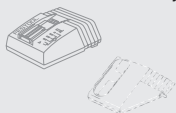

### The Festool system.

Because things work better when everything fits together: System accessories, matching quick-change attachments, a diverse range of screwdriver and drill bits as well as ingenious battery packs with a charge indicator have made Festool cordless drill and rotary impact driver series even better, more flexible and reliable.



## Drilling and screwdriving

Accessories and consumable materials

System accessories	214
CENTROTEC tool range	218
Hammer drill bit for cordless hammer drill BHC 18	222
CENTROTEC Forstner drill bit system ZOBO	223
ZOBO drilling systems	223
CENTROTEC other accessoires	224
Guide systems for drilling	225
Accessories for drywall screwdriver DWC	225



# Drilling and screwdriving

## System accessories

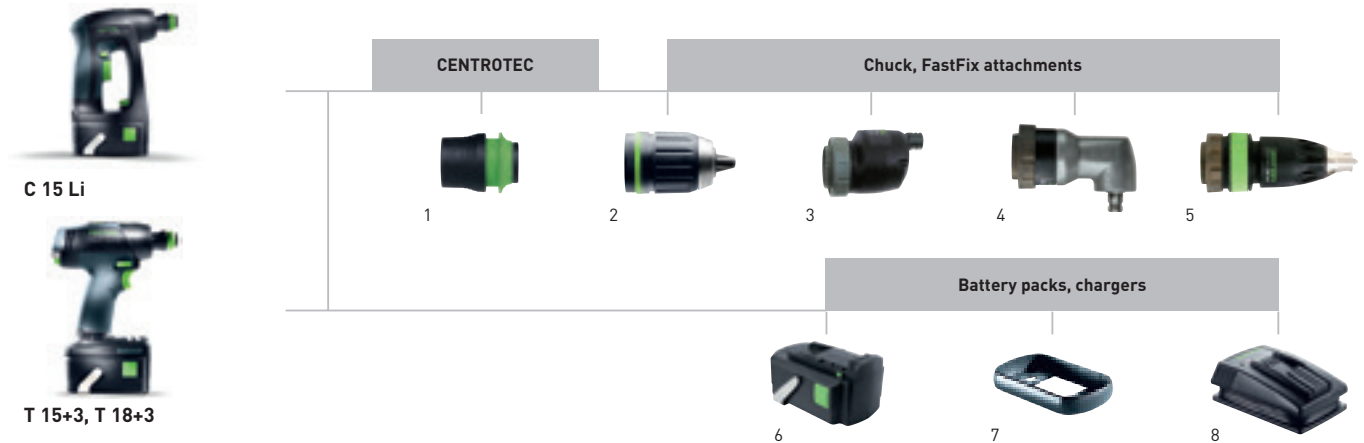

### Accessories for cordless drills C 15, T+3 series

Denomination	Explanation	RRP in £*	Order no.
<b>1 Tool chuck WH-CE CENTROTEC</b>	for all Festool cordless and mains-operated drills (except DR 20/DRP 20) with CENTROTEC interface, in self-service display pack	17,85 21,42	<b>492135</b>
<b>2 Keyless chuck BF-FX 10 FastFix</b>	for all Festool cordless and mains-operated drills (except DR 20/DRP 20) with CENTROTEC interface, Clamping range 1-10 mm, in self-service display pack	42,30 50,76	<b>491350</b>
<b>Keyless chuck KC 13-1/2-K-FFP</b>	for all Festool cordless drills, cordless impact drills, drills (except DR 20/DRP 20) and impact drills with CENTROTEC interface, impact resistant, plastic ring, with locking device, tool reception FastFix, Clamping range 1,5-13 mm, in self-service display pack	45,90 55,08	<b>769067</b>
<b>3 FastFix eccentric attachment DD-ES</b>	for all Festool C and T cordless drills with FastFix interfaces, except CXS, in self-service display pack	81,15 97,38	<b>490294</b>
<b>4 FastFix angle attachment DD-AS</b>	for all Festool C and T cordless drills with FastFix interfaces, except CXS, in self-service display pack	81,15 97,38	<b>490293</b>
<b>5 Depth stop FastFix DD-DC</b>	for all Festool C and T cordless drills with FastFix interfaces, except CXS, in self-service display pack	81,15 97,38	<b>493539</b>
<b>6 Battery pack BPC 15 5.2 Ah-Li Ion</b>	lithium-ion spare battery for cordless drills T 15+3, C 15 Li, TI 15 IMPACT and PSC/PSBC 420, Capacity 5,2 Ah, weight 0,580 kg, Voltage 14,4 V, in self-service display pack	67,95 81,54	<b>500434</b>
<b>Battery pack BPC 18 5.2 Ah-Li Ion</b>	lithium-ion spare battery for cordless drills T 18+3, DRC 18/4, PDC 18/4, BHC 18, DWC 18 and PSC/PSBC 420, TSC 55, Capacity 5,2 Ah, weight 0,680 kg, Voltage 18 V, in self-service display pack	76,45 91,74	<b>500435</b>
<b>7 Rubber frame GR-BPC 15/18</b>	for all BPC 15/18 battery packs, replacement frame for battery packs on DRC 18/4, PDC 18/4, BHC 18, DWC 18-4500, DWC 18-2500, in self-service display pack	4,75 5,70	<b>769240</b>
<b>8 Charger TCL 3 GB 240 V</b>	replacement charger for cordless drills C 12, TDK 12, T 12+3, C 15, TDK 15.6, T 15+3, TI 15, T 18+3, BHC 18, PS(B)C 400/420, TSC 55, DRC 18/4, PDC 18/4, DWC 18-2500 and DWC 18-4500, charger for NiCd, NiMH and li-ion battery packs, charging current 3.0 A, input voltage 220-240 V, in a carton	42,50 51,00	<b>499413</b>





CXS

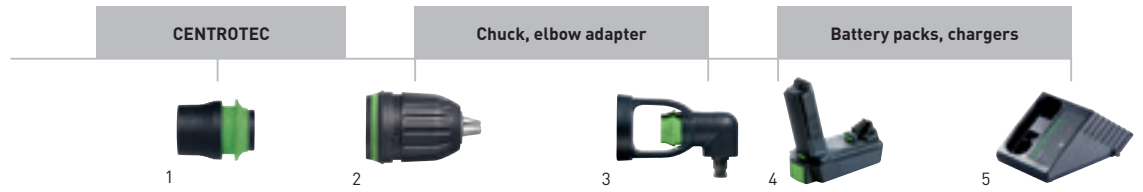

BHC 18

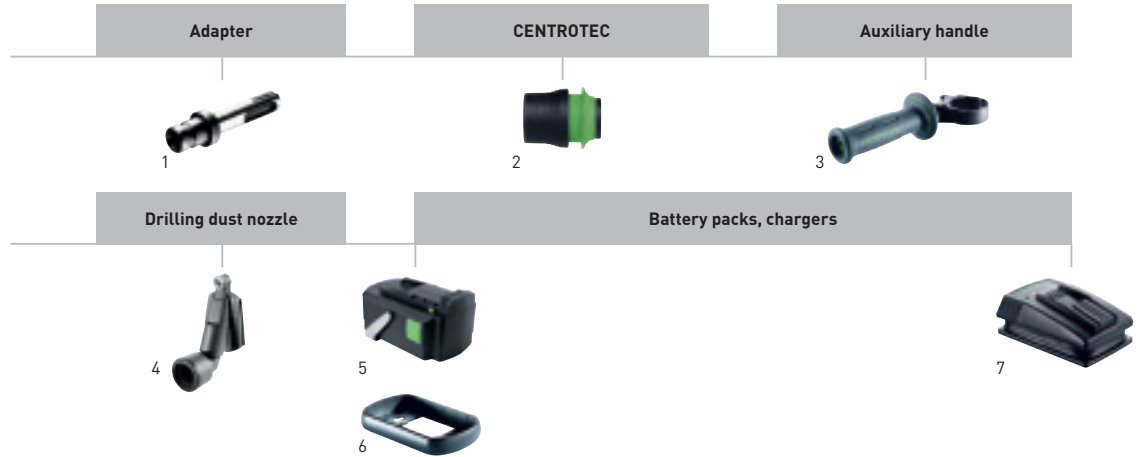

### Accessories for cordless drill CXS

Denomination	Explanation	RRP in £*	Order no.
1 Tool chuck WH-CE CENTROTEC	for all Festool cordless and mains-operated drills (except DR 20/DRP 20) with CENTROTEC interface, in self-service display pack	17,85 21,42	492135
2 Keyless chuck BF-FX 8 FastFix	for CXS cordless drills, Clamping range 1-8 mm, in self-service display pack	29,80 35,76	497216
3 Angle attachment XS-AS	for CXS, for working in tight spaces, in self-service display pack	55,20 66,24	497951
4 Battery pack BP-XS 1,5 Ah	lithium-ion spare battery for cordless drills CXS, Capacity 1,5 Ah, weight 0,200 kg, Voltage 10,8 V, in self-service display pack	65,65 78,78	498616
5 Charger MXC	for CXS and TXS cordless drills, for BP-XS battery packs, charging current 2,8 A, input voltage 220-240 V, in a carton	42,50 51,00	497496

### Accessories for cordless hammer drill BHC 18

Denomination	Explanation	RRP in £*	Order no.
1 Adapter AD SDS-plus/FastFix	for BHC 18, RHP 18, CHP 26, for holding a CENTROTEC tool chuck, in self-service display pack	13,75 16,50	769068
2 Tool chuck WH-CE CENTROTEC	for all Festool cordless and mains-operated drills (except DR 20/DRP 20) with CENTROTEC interface, in self-service display pack	17,85 21,42	492135
3 Auxiliary handle AH-43/185	for all QUADRIVE DRC 18/4, PDC 18/4 and BHC 18, for absorbing higher torques, Length 185 mm, holder Ø 43 mm, in self-service display pack	8,30 9,96	768615
4 Drilling dust nozzle D 27-BSD	for BHC 18, PDC 18, PD 20 and mobile dust extractors CT/CTL/CTM, drill sleeve made from nickel-plated steel, compatible with all standard industrial and domestic vacuum cleaners, exception: must be deactivated on extractors with automatic filter cleaning system, adapter with flexible insert, connection Ø 27-32 mm, drill bit dia. 0-12 mm, in self-service display pack	14,10 16,92	500483
5 Battery pack BPC 18 5.2 Ah-Li Ion	lithium-ion spare battery for cordless drills T 18+3, DRC 18/4, PDC 18/4, BHC 18, DWC 18 and PSC/PSBC 420, TSC 55, Capacity 5,2 Ah, weight 0,680 kg, Voltage 18 V, in self-service display pack	76,45 91,74	500435
6 Rubber frame GR-BPC 15/18	for all BPC 15/18 battery packs, replacement frame for battery packs on DRC 18/4, PDC 18/4, BHC 18, DWC 18-4500, DWC 18-2500, in self-service display pack	4,75 5,70	769240
7 Charger TCL 3 GB 240 V	replacement charger for cordless drills C 12, TDK 12, T 12+3, C 15, TDK 15.6, T 15+3, TI 15, T 18+3, BHC 18, PS(B)C 400/420, TSC 55, DRC 18/4, PDC 18/4, DWC 18-2500 and DWC 18-4500, charger for NiCd, NiMH and li-ion battery packs, charging current 3.0 A, input voltage 220-240 V, in a carton	42,50 51,00	499413

# Drilling and screwdriving

## System accessories

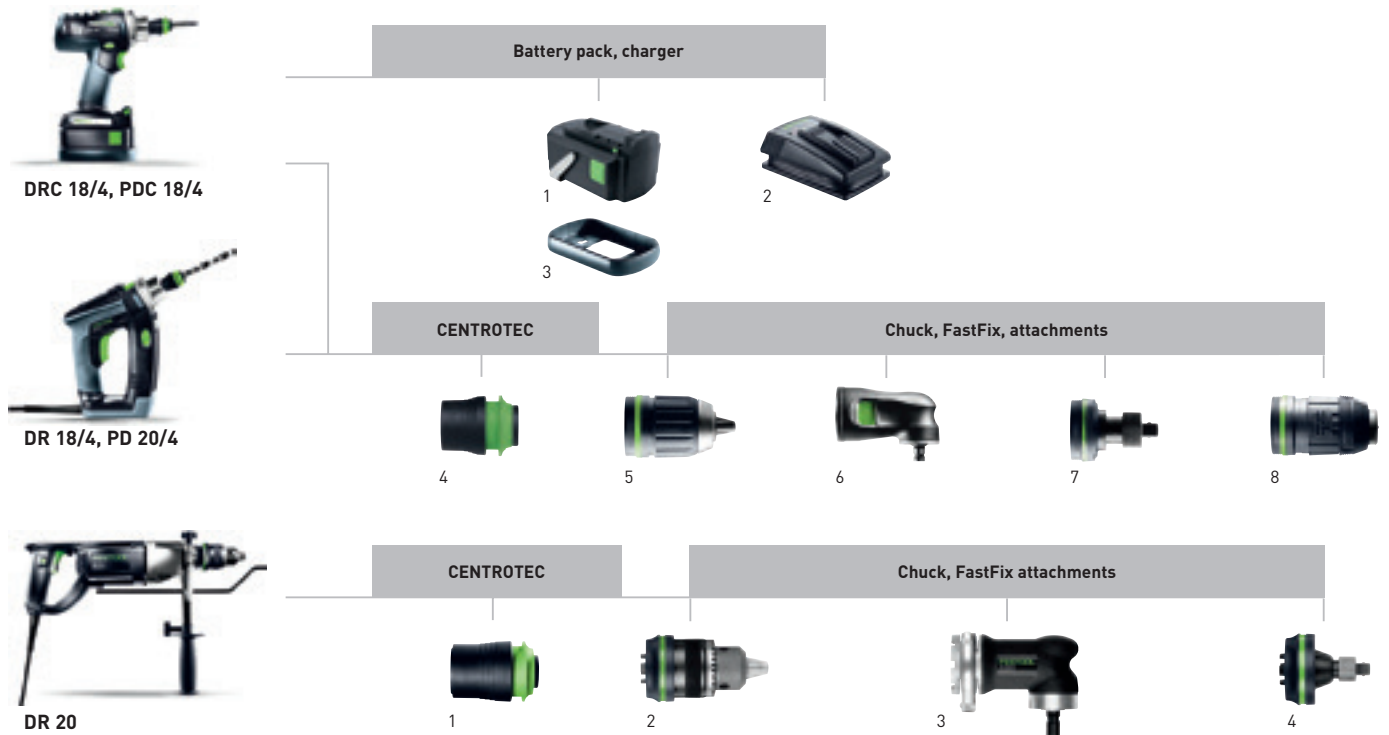

### Accessories for cordless drills QUADRIVE DRC 18/4, cordless impact drills QUADRIVE PDC 18/4, drills QUADRILL DR 18/4, impact drills QUADRILL PD 20/4

Denomination	Explanation	RRP in £*	Order no.
<b>1 Battery pack BPC 18 5.2 Ah-Li Ion</b>	lithium-ion spare battery for cordless drills T 18+3, DRC 18/4, PDC 18/4, BHC 18, DWC 18 and PSC/PSBC 420, TSC 55, Capacity 5,2 Ah, weight 0,680 kg, Voltage 18 V, in self-service display pack	76,45 91,74	<b>500435</b>
<b>2 Charger TCL 3 GB 240 V</b>	replacement charger for cordless drills C 12, TDK 12, T 12+3, C 15, TDK 15.6, T 15+3, TI 15, T 18+3, BHC 18, PS(B)C 400/420, TSC 55, DRC 18/4, PDC 18/4, DWC 18-2500 and DWC 18-4500, charger for NiCd, NiMH and li-ion battery packs, charging current 3.0 A, input voltage 220-240 V, in a carton	42,50 51,00	<b>499413</b>
<b>3 Rubber frame GR-BPC 15/18</b>	for all BPC 15/18 battery packs, replacement frame for battery packs on DRC 18/4, PDC 18/4, BHC 18, DWC 18-4500, DWC 18-2500, in self-service display pack	4,75 5,70	<b>769240</b>
<b>4 Tool chuck WH-CE CENTROTEC</b>	for all Festool cordless and mains-operated drills (except DR 20/DRP 20) with CENTROTEC interface, in self-service display pack	17,85 21,42	<b>492135</b>
<b>5 Keyless chuck KC 13-1/2-K-FFP</b>	for all Festool cordless drills, cordless impact drills, drills (except DR 20/DRP 20) and impact drills with CENTROTEC interface, impact resistant, plastic ring, with locking device, tool reception FastFix, Clamping range 1,5-13 mm, in self-service display pack	45,90 55,08	<b>769067</b>
<b>Keyless chuck KC 13-1/2-MMFP</b>	for all Festool cordless drills, cordless impact drills, drills (except DR 20/DRP 20) and impact drills with CENTROTEC interface, impact-resistant, metal ring, with locking device., tool reception FastFix, Clamping range 1,5-13 mm, in self-service display pack	53,10 63,72	<b>769065</b>
<b>6 Angle attachment AU-43 FFP</b>	for DRC 18/4, PDC 18/4, DR 18/4 E, PD 20/4 E, DRP 16 ET, DRP 18-4 DEC, PDP 20-4 DEC, tool reception FastFix, collar Ø 43 mm, in self-service display pack	128,55 154,26	<b>769097</b>
<b>7 Adapter AD-3/8" FF</b>	for DRC 18/4, PDC 18/4, DR 18/4 E, PD 20/4 E, DRP 16 ET, DRP 18-4 DEC, PDP 20-4 DEC and all C+T drivers, for holding socket wrenches with 3/8" square i.a.w. DIN 3121 (machine-operated assembly tools), tool reception FastFix, in self-service display pack	46,85 56,22	<b>769064</b>
<b>8 Depth stop DC UNI FF</b>	for DRC 18/4, PDC 18/4, DR 18/4 E, PD 20/4 E, DRP 16 ET, DRP 18-4 DEC, PDP 20-4 DEC and all C+T drivers, stop sleeves Ø 17 mm + 23 mm, bit PH 2, socket wrench, size 8, tool reception FastFix, in self-service display pack	89,55 107,46	<b>769126</b>

### Accessories for QUADRILL DR 20

Denomination	Explanation	RRP in £*	Order no.
<b>1 CENTROTEC CC-XL CENTROTEC</b>	for DR 20 E FF, DRP 20 ET FF, DRP 20-2 E FF, for holding CENTROTEC tools, tool reception FastFix, in self-service display pack	29,70 35,64	<b>769071</b>
<b>2 Key-type chuck CC-16 FFP</b>	for DR 20 E FF, DRP 20 ET FF, DRP 20-2 E FF, with wrench and locking device, tool reception FastFix, Clamping range 3-16 mm, in self-service display pack	95,35 114,42	<b>769061</b>
<b>3 Angle chuck AU DR 20</b>	for DR 20 E FF, DRP 20 ET FF, DRP 20-2 E FF, tool reception FastFix, collar Ø 57 mm, in self-service display pack	155,50 186,60	<b>769060</b>
<b>4 Adapter AD-1/2 FF</b>	for DR 20 E FF, DRP 20 ET FF, DRP 20-2 E FF, for quick-change adapters, For holding socket wrenches with 1/2" square, tool reception FastFix, in self-service display pack	53,80 64,56	<b>769062</b>



### Accessories for cordless drywall screwdrivers DURADRIVE DWC 18



Denomination	Explanation	RRP in £*	Order no.
<b>1 Magazine attachment AF 55-DWC</b>	for DWC, DWP, for taped screws, 25-55 mm, 1 bit PH2, long, in a carton	159,90 191,88	<b>769146</b>
<b>2 Bits PH2-AF-55 3x</b>	AF 55-DWP/DWC, Size PH 2, qty. in pack 3 piece(s), in self-service display pack	13,75 16,50	<b>769124</b>
<b>Bits PZ2-AF-55 3x</b>	AF 55-DWP/DWC, Size PZ 2, qty. in pack 3 piece(s), in self-service display pack	13,75 16,50	<b>769078</b>
<b>3 Bit holder BH-DWC</b>	for DWC, DWP, qty. in pack 1 piece(s), in self-service display pack	7,05 8,46	<b>769125</b>
<b>4 Battery pack BPC 18 5.2 Ah-Li Ion</b>	lithium-ion spare battery for cordless drills T 18+3, DRC 18/4, PDC 18/4, BHC 18, DWC 18 and PSC/PSBC 420, TSC 55, Capacity 5,2 Ah, weight 0,680 kg, Voltage 18 V, in self-service display pack	76,45 91,74	<b>500435</b>
<b>5 Charger TCL 3 GB 240 V</b>	replacement charger for cordless drills C 12, TDK 12, T 12+3, C 15, TDK 15.6, T 15+3, TI 15, T 18+3, BHC 18, PS(B)C 400/420, TSC 55, DRC 18/4, PDC 18/4, DWC 18-2500 and DWC 18-4500, charger for NiCd, NiMH and li-ion battery packs, charging current 3.0 A, input voltage 220-240 V, in a carton	42,50 51,00	<b>499413</b>
<b>6 Rubber frame GR-BPC 15/18</b>	for all BPC 15/18 battery packs, replacement frame for battery packs on DRC 18/4, PDC 18/4, BHC 18, DWC 18-4500, DWC 18-2500, in self-service display pack	4,75 5,70	<b>769240</b>

# Drilling and screwdriving

## System accessories

### 25 mm bits

#### Standard bits





	Type	RRP in £*	Order no.
 <b>PZ bit</b> Length 25 mm, qty. in pack 10 piece(s) Size PZ 1	PZ 1-25/10	7,20 8,64	<b>490481</b>
	PZ 2-25/10	7,20 8,64	<b>490482</b>
	PZ 3-25/10	7,20 8,64	<b>490483</b>
 <b>PH bit</b> Length 25 mm, qty. in pack 10 piece(s) Size PH 1	PH 1-25/10	7,20 8,64	<b>490501</b>
	PH 2-25/10	7,20 8,64	<b>490502</b>
	PH 3-25/10	7,20 8,64	<b>490503</b>
 <b>TX bit</b> Length 25 mm, qty. in pack 10 piece(s) Size TX 10	TX 10-25/10	9,95 11,94	<b>490504</b>
	TX 15-25/10	9,95 11,94	<b>490505</b>
	TX 20-25/10	9,95 11,94	<b>490506</b>
	TX 25-25/10	9,95 11,94	<b>490507</b>
	TX 30-25/10	9,95 11,94	<b>490508</b>
 <b>twinBOX</b> in a carton 8x twinbox PZ, content 10 pieces, 3x PZ 1, 4x PZ 2, 3x PZ 3 8x twinbox TX 8x twinbox Mix, content 10 pieces, PH 1, PH 2, PZ 1, PZ 2, PZ 3, TX 15, TX 20, TX 25, TX 30, SZ 0.8x55	BB-PZ/8x	89,25 107,10	<b>496930</b>
	BB-TX/8x	89,25 107,10	<b>496931</b>
	BB-MIX/8x	89,25 107,10	<b>496932</b>

#### ImpactPlus bits: impact-resistant, robust, durable

	Type	RRP in £*	Order no.
 <b>PZ bit</b> Length 25 mm, qty. in pack 5 piece(s) Size PZ 1	PZ 1-25 IMP/5	11,75 14,10	<b>499930</b>
	PZ 2-25 IMP/5	11,20 13,44	<b>498919</b>
	PZ 3-25 IMP/5	11,20 13,44	<b>498920</b>
 <b>PH bit</b> Length 25 mm, qty. in pack 5 piece(s) Size PH 1	PH 1-25 IMP/5	11,75 14,10	<b>499929</b>
	PH 2-25 IMP/5	11,20 13,44	<b>498917</b>
	PH 3-25 IMP/5	11,20 13,44	<b>498918</b>
 <b>TX bit</b> Length 25 mm, qty. in pack 5 piece(s) Size TX 10	TX 10-25 IMP/5	12,35 14,82	<b>499931</b>
	TX 15-25 IMP/5	12,35 14,82	<b>499932</b>
	TX 20-25 IMP/5	11,65 13,98	<b>498921</b>
	TX 25-25 IMP/5	11,65 13,98	<b>498922</b>
	TX 30-25 IMP/5	11,65 13,98	<b>498923</b>
	TX 40-25 IMP/5	11,65 13,98	<b>498924</b>
 <b>twinBOX</b> 8x twinbox impact plus, 8-piece, 2x PZ 2-25, 2x PZ 3-25, 2x TX 20, TX 30, TX 40, in a carton	impactplus-MIX/8	155,20 186,24	<b>498831</b>







### CENTROTEC tool range

#### 100 mm bits

		Type	RRP in £*	Order no.
	<b>PZ bit</b> Length 100 mm, qty. in pack 2 piece(s)			
	Size PZ 1	PZ 1-100 CE/2	12,60 15,12	<b>492527</b>
	Size PZ 2	PZ 2-100 CE/2	12,60 15,12	<b>492528</b>
	Size PZ 3	PZ 3-100 CE/2	12,60 15,12	<b>492529</b>
	<b>PH bit</b> Length 100 mm, qty. in pack 2 piece(s)			
	Size PH 1	PH 1-100 CE/2	12,60 15,12	<b>492530</b>
	Size PH 2	PH 2-100 CE/2	12,60 15,12	<b>492531</b>
	Size PH 3	PH 3-100 CE/2	12,60 15,12	<b>492532</b>
	<b>Slot bit</b> Length 100 mm, qty. in pack 2 piece(s)			
	Size SZ 0,8x5,5	SZ 0,8x5,5-100 CE/2	12,60 15,12	<b>492537</b>
	Size SZ 1,2x6,5	SZ 1,2x6,5-100 CE/2	12,60 15,12	<b>492538</b>
	<b>TX bit</b> for all Festool cordless drills with FastFix interface, Length 100 mm, qty. in pack 2 piece(s)			
	Size TX 15	TX 15-100 CE/2	12,60 15,12	<b>492533</b>
	Size TX 20	TX 20-100 CE/2	12,60 15,12	<b>492534</b>
	Size TX 25	TX 25-100 CE/2	12,60 15,12	<b>492535</b>
	Size TX 30	TX 30-100 CE/2	12,60 15,12	<b>492536</b>
	<b>Bits</b> for SYS TL with lid compartment, 6 CENTROTEC bits: PZ 2-100 CE, PZ 3-100 CE, TX 15-100 CE, TX 20-100 CE, TX 25-100 CE, TX 30-100 CE, qty. in pack 6 piece(s)	CENTROTEC BITS CE SET TL 6X	33,70 40,44	<b>769095</b>

05





#### Bits and bit holders

		Type	RRP in £*	Order no.
	<b>Bit box</b>			
	for all Festool cordless drills with FastFix interface, content 10 pieces, 2x PZ 1, 5x PZ 2, 2x PZ 3, CENTROTEC magnetic bit fastener BH 60 CE	PZ + BH 60-CE	14,55 17,46	<b>493260</b>
	for all Festool cordless drills with FastFix interface, content 10 pieces, TX 10, 2x TX 15, 3x TX 20, 2x TX 25, TX 30, CENTROTEC magnetic bit fastener BH 60 CE	TX + BH 60-CE	14,55 17,46	<b>493261</b>
	for all Festool cordless drills with FastFix interface, content 10 pieces, PH 1, PH 2, PZ 1, PZ 2, PZ 3, TX 15, TX 20, TX 25, SZ 0,8x55, CENTROTEC magnetic bit fastener BH 60 CE	MIX + BH 60-CE	14,55 17,46	<b>493262</b>
	for SYS TL with lid compartment, 24-piece, 2 standard bits: PH 1, PH 2, PH 3, PZ 1, PZ 2, PZ 3, TX 10, TX 15, TX 20, TX 25, TX 30, TX 40, 1 CENTROTEC quick-change bit holder: BHS 65 CE	BITS + BHS 65 CE TL 24x	29,85 35,82	<b>769094</b>
	for all Festool cordless drills with FastFix interface, qty. in pack 1 piece(s)	BHS 65 CE	22,65 27,18	<b>492648</b>
	for all Festool cordless drills with FastFix interface, qty. in pack 1 piece(s)	BV 150 CE	18,15 21,78	<b>492540</b>
	for all Festool cordless drills with FastFix interface, also suitable for use with impact screwdriver TI15 Impact, qty. in pack 1 piece(s)	BH 60 CE-Imp	9,20 11,04	<b>498974</b>
	for all Festool cordless drills with FastFix interface, for plug-in bits, with ball lock for manual operation, tool reception 1/4", Length 50 mm	1/4"-50 CE/KG CENTROTEC	17,95 21,54	<b>495131</b>
	for all Festool cordless drills with FastFix interface, for plug-in bits, with ball lock for manual operation, tool reception 3/8", Length 70 mm	3/8"-70 CE/KG CENTROTEC	25,60 30,72	<b>495133</b>
	for CENTROTEC tools for drilling and screwdriving	CENTROTEC-DRIVE	17,20 20,64	<b>495228</b>

# Drilling and screwdriving



## System accessories

### Bit cassette

		Type	RRP in £*	Order no.
	<b>Bit cassette</b> 31-piece, 1 magnetic bit holder 1/4", 3 x TX 10, TX 15, 6 x TX 20, TX 25, TX 30, each 3x TX 40, TX 50	TX 10-50/BH-SORT/31x	25,95 31,14	<b>769137</b>
	31-piece, 1 magnetic bit holder 1/4", 2x TX 10, TX 15, TX 20, TX 25, TX 30, TX 40, PH 1, PH 2, PH 3, PZ 1, PZ 2, PZ 3, 1x LS 4,5; LS 5,5; LS 6,5; HEX 4; HEX 5; HEX 6	BIT/BH-SORT/31x	25,95 31,14	<b>769138</b>
	1/4" socket set from 4 to 13 mm, 19 different bit inserts and 2 bit extensions, ratchet and CENTROTEC handle plus various adapters and extensions, in a SYSTAINER SYS MINI	1/4"-CE RA-Set 37	105,70 126,84	<b>497881</b>
	for all Festool cordless drills with FastFix interface, CENTROTEC-DRIVE screwdriver handle, WH-CE CENTROTEC tool chuck, magnetic bit holder BH-60 CE, extra-long CENTROTEC magnetic bit holder BV 150 CE, CENTROTEC drill adapter BA-CE, deburring countersink QLS D2-8 CE, deburring countersink QLS D5-15 CE, drill bit with depth stop BTA HW D5 CE, drill countersink with depth stop, BSTA HS D3.5 CE, centering bit ZB HS D5 EURO CE, hook driver HD D18 CE, twinBOX Mix, drill bit case HSS D3-10 CE/10, drill bit case BKS D3-8 CE/W-K, 12x long CENTROTEC bits PZ/PH/TX, bit assortment 25 mm, 50 pieces, in a SYSTAINER SYS 1 T-LOC	SYS 1 CE-SORT	338,15 405,78	<b>497628</b>

### CENTROTEC HSS twist drill bit, sanded DIN 338

#### Standard drill bit programme

		Type	RRP in £*	Order no.
	<b>Twist drill bit</b> hexagon socket wrench, qty. in pack 1 piece(s)			
	complete drill bit with bit holder and 2 replacement drill bits, Diameter 3 mm	HSS D 3/33 CE/M-Set	7,20 8,64	<b>493421</b>
	complete drill bit with bit holder and 2 replacement drill bits, Diameter 3,5 mm	HSS D 3,5/39 CE/M-Set	7,45 8,94	<b>493422</b>
	complete drill bit with bit holder and 2 replacement drill bits, Diameter 4 mm	HSS D 4/43 CE/M-Set	7,70 9,24	<b>493423</b>
	complete drill bit with bit holder and 2 replacement drill bits, Diameter 4,5 mm	HSS D 4,5/47 CE/M-Set	8,95 10,74	<b>493424</b>
	complete drill bit with bit holder and 2 replacement drill bits, Diameter 5 mm	HSS D 5/52 CE/M-Set	9,20 11,04	<b>493425</b>
	complete drill bit with bit holder and 2 replacement drill bits, Diameter 5,5 mm	HSS D 5,5/57 CE/M-Set	9,35 11,22	<b>493426</b>
	complete drill bit with bit holder and 2 replacement drill bits, Diameter 6 mm	HSS D 6/57 CE/M-Set	9,75 11,70	<b>493427</b>
	complete drill bit with bit holder and 2 replacement drill bits, Diameter 6,5 mm	HSS D 6,5/63 CE/M-Set	10,35 12,42	<b>493428</b>
	complete drill bit with bit holder and 1 replacement drill bit, Diameter 8 mm	HSS D 8,0/75 CE/M-Set	15,95 19,14	<b>495308</b>
	complete drill bit with bit holder and 1 replacement drill bit, Diameter 10 mm	HSS D 10,0/75 CE/M-Set	20,05 24,06	<b>495309</b>
	<b>Twist drill bit</b> Drill bit case, Diameter 3-10 mm, qty. in pack 10 piece(s)	HSS D3-10 CE/10	75,65 90,78	<b>495128</b>
	<b>Twist drill bit</b> spare part drill bit for CENTROTEC twist drill bit M Set			
	Diameter 3 mm, qty. in pack 10 piece(s)	HSS D 3/33 M/10	8,40 10,08	<b>493437</b>
	Diameter 3,5 mm, qty. in pack 10 piece(s)	HSS D 3,5/39 M/10	8,95 10,74	<b>493438</b>
	Diameter 4 mm, qty. in pack 10 piece(s)	HSS D 4/43 M/10	11,20 13,44	<b>493439</b>
	Diameter 4,5 mm, qty. in pack 10 piece(s)	HSS D 4,5/47 M/10	12,70 15,24	<b>493440</b>
	Diameter 5 mm, qty. in pack 10 piece(s)	HSS D 5/52 M/10	13,90 16,68	<b>493441</b>
	Diameter 5,5 mm, qty. in pack 10 piece(s)	HSS D 5,5/57 M/10	15,00 18,00	<b>493442</b>
	Diameter 6 mm, qty. in pack 10 piece(s)	HSS D 6/57 M/10	16,30 19,56	<b>493443</b>
	Diameter 6,5 mm, qty. in pack 10 piece(s)	HSS D 6,5/63 M/10	18,35 22,02	<b>493444</b>
	Diameter 8 mm, qty. in pack 5 piece(s)	HSS D 8,0/75 M/5	19,95 23,94	<b>495310</b>
	Diameter 10 mm, qty. in pack 5 piece(s)	HSS D 10,0/75 M/5	29,25 35,10	<b>495311</b>



**CENTROTEC wood twist drill bit and stone drill bit**

Drill bit	Type	RRP in £*	Order no.
 <p><b>Drill bit</b> for all Festool cordless drills with FastFix interface, qty. in pack 1 piece(s)</p>	Diameter 3 mm	D 3 CE/W 7,30 8,76	<b>492512</b>
	Diameter 4 mm	D 4 CE/W 7,30 8,76	<b>492513</b>
	Diameter 5 mm	D 5 CE/W 7,70 9,24	<b>492514</b>
	Diameter 6 mm	D 6 CE/W 8,00 9,60	<b>492515</b>
	Diameter 7 mm	D 7 CE/W 8,10 9,72	<b>492516</b>
	Diameter 8 mm	D 8 CE/W 9,85 11,82	<b>492517</b>
	Diameter 10 mm	D 10 CE/W 11,50 13,80	<b>492518</b>

**Spiral wood drill bit box, large**

Drill bit case	Type	RRP in £*	Order no.
 <p><b>Drill bit case</b> with brad point, long drill bit case, Diameter 3, 4, 5, 6, 8 mm, qty. in pack 5 piece(s)</p>	BKS D 3-8 CE/W	37,60 45,12	<b>493648</b>



**Spiral wood drill bit box, small**

Drill bit case	Type	RRP in £*	Order no.
 <p><b>Drill bit case</b> with brad point, short drill bit case, Diameter 3, 4, 5, 6, 8 mm, qty. in pack 5 piece(s)</p>	BKS D 3-8 CE/W-K	34,20 41,04	<b>495130</b>
 <p>6 CENTROTEC wood twist drills, Diameter 4, 2x5, 6, 8, 10 mm, qty. in pack 6 piece(s)</p>	DB WOOD CE SET TL 6x	46,15 55,38	<b>769093</b>

**HSS steel drill**

Drill bit box for HSS steel drill bits	Type	RRP in £*	Order no.
 <p><b>Drill bit box for HSS steel drill bits</b> Drill bit case, Diameter 1-10 mm, qty. in pack 19 piece(s)</p>	HSS D 1-10 Sort/19	45,55 54,66	<b>498981</b>

**CENTROTEC masonry drills with carbide-tipped cutter**

Masonry drill	Type	RRP in £*	Order no.
 <p><b>Masonry drill</b> qty. in pack 3 piece(s)</p>	Diameter 4 mm	DB STONE CE D4 3x 22,30 26,76	<b>769111</b>
	Diameter 5 mm	DB STONE CE D5 3x 22,80 27,36	<b>769112</b>
	Diameter 6 mm	DB STONE CE D6 3x 24,80 29,76	<b>769113</b>
	Diameter 8 mm	DB STONE CE D8 3x 27,00 32,40	<b>769114</b>
	Diameter 10 mm	DB STONE CE D10 3x 30,05 36,06	<b>769115</b>
	 <p><b>Masonry drill</b> for SYS TL with lid compartment, 6 CENTROTEC masonry drill bits: dia. 4, 5, 2 x 6, 8, 10 mm</p>	DB STONE CE SET TL 6x	43,30 51,96

## Drilling and screwdriving



### System accessories

#### Hammer drill bit range for cordless hammer drill BHC 18

	Type	RRP in £*	Order no.
 <b>Hammer drill</b>			
Diameter 5 mm, l1 50 mm, l2 110 mm, qty. in pack 2 piece(s)	SDS-Plus D5x50/2	13,00 15,60	<b>499910</b>
Diameter 5 mm, l1 100 mm, l2 160 mm, qty. in pack 2 piece(s)	SDS-Plus D5x100/2	15,05 18,06	<b>499911</b>
Diameter 6 mm, l1 50 mm, l2 110 mm, qty. in pack 3 piece(s)	SDS-Plus D6x50/3	16,95 20,34	<b>499912</b>
Diameter 6 mm, l1 100 mm, l2 160 mm, qty. in pack 3 piece(s)	SDS-Plus D6x100/3	20,25 24,30	<b>499913</b>
Diameter 6 mm, l1 200 mm, l2 260 mm, qty. in pack 3 piece(s)	SDS-Plus D 6 x 200/3	36,55 43,86	<b>500734</b>
Diameter 6,5 mm, l1 200 mm, l2 260 mm, qty. in pack 3 piece(s)	SDS-Plus D 6,5 x 200/3	41,65 49,98	<b>500735</b>
Diameter 8 mm, l1 100 mm, l2 160 mm, qty. in pack 2 piece(s)	SDS-Plus D8x100/2	16,95 20,34	<b>499914</b>
Diameter 8 mm, l1 200 mm, l2 260 mm, qty. in pack 1 piece(s)	SDS-Plus D8x200	12,75 15,30	<b>499915</b>
Diameter 8 mm, l1 250 mm, l2 310 mm, qty. in pack 1 piece(s)	SDS-Plus D8x250	17,65 21,18	<b>499916</b>
Diameter 8 mm, l1 400 mm, l2 460 mm, qty. in pack 1 piece(s)	SDS-Plus D8x400	28,65 34,38	<b>499917</b>
 Diameter 10 mm, l1 100 mm, l2 160 mm, qty. in pack 1 piece(s)	SDS-Plus D10x100	10,90 13,08	<b>499918</b>
Diameter 10 mm, l1 200 mm, l2 260 mm, qty. in pack 1 piece(s)	SDS-Plus D10x200	14,90 17,88	<b>499919</b>
Diameter 10 mm, l1 250 mm, l2 310 mm, qty. in pack 1 piece(s)	SDS-Plus D10x250	17,25 20,70	<b>499920</b>
Diameter 12 mm, l1 100 mm, l2 160 mm, qty. in pack 1 piece(s)	SDS-Plus D12x100	12,15 14,58	<b>499921</b>
Diameter 12 mm, l1 200 mm, l2 265 mm, qty. in pack 1 piece(s)	SDS-Plus D12x200	17,85 21,42	<b>499922</b>
Diameter 14 mm, l1 200 mm, l2 260 mm, qty. in pack 1 piece(s)	SDS-Plus D14x200	23,35 28,02	<b>499923</b>
 for cordless hammer drills BHC 18 and all other hammer drills with SDS-Plus tool reception, 1 x D 5x50, 2 x D 6x50, 1 x D 6x100, 1 x D 8x100, 1 x D 10x100, 1 x D 12x100qty. in pack 7 piece(s)	SDS+Set	52,55 63,06	<b>499924</b>



### CENTROTEC Forstner drill bit system ZOBO

		Type	RRP in £*	Order no.
	<b>Forstner drill bit, ZOBO system</b> qty. in pack 1 piece(s)			
	Diameter 15 mm	FB D 15 CE-Zobo	18,75 22,50	<b>496472</b>
	Diameter 20 mm	FB D 20 CE-Zobo	23,55 28,26	<b>496473</b>
	Diameter 25 mm	FB D 25 CE-Zobo	28,50 34,20	<b>496474</b>
	Diameter 30 mm	FB D 30 CE-Zobo	33,30 39,96	<b>496475</b>
	Diameter 35 mm	FB D 35 CE-Zobo	38,15 45,78	<b>496476</b>
	<b>Drill bit set, ZOBO system</b> Drill bit case, 5 drill bits D 15-35, Diameter 15-35 mm, qty. in pack 5 piece(s)	FB Set D 15-35 CE-Zobo	125,75 150,90	<b>496390</b>
	<b>Spare part set ZOBO</b> centre points (FB-CE 2.5x3.5/ZS and FB-CE 2.5x7.5/ZS), centring bit (FB-CE 2.5x30/ZB) and punch (FB-Set-D 15-35 CE), for CENTROTEC Forstner drill bit	FB-CE/Er-Zobo	14,55 17,46	<b>497268</b>



### ZOBO drilling system

		Type	RRP in £*	Order no.
	<b>Zobo drill bit</b>			
	for all cordless screwdrivers and drills with keyless chuck, this article is also available in Set, drill bit dia. 15 mm, shank dia. 9 mm, Total length 100 mm	WD C 15x100 S2	35,50 42,60	<b>768799</b>
	this article is also available in Set, for banister bore holes with staircase drill GD D10-40 A, drill bit dia. 18 mm, shank dia. 9 mm, Total length 100 mm	WD C 18x100 S2	36,25 43,50	<b>769362</b>
	for all cordless screwdrivers and drills with keyless chuck, this article is also available in Set, drill bit dia. 20 mm, shank dia. 9 mm, Total length 100 mm	WD C 20x100 S2	38,85 46,62	<b>768483</b>
	this article is also available in Set, for banister bore holes with staircase drill GD D10-40 A, drill bit dia. 22 mm, shank dia. 9 mm, Total length 100 mm	WD C 22x100 S2	43,55 52,26	<b>769363</b>
	for all cordless screwdrivers and drills with keyless chuck, this article is also available in Set, drill bit dia. 25 mm, shank dia. 9 mm, Total length 100 mm	WD C 25x100 S2	48,10 57,72	<b>768288</b>
	for all cordless screwdrivers and drills with keyless chuck, this article is also available in Set, drill bit dia. 30 mm, shank dia. 9 mm, Total length 100 mm	WD C 30x100 S2	58,75 70,50	<b>768166</b>
	for all cordless screwdrivers and drills with keyless chuck, this article is also available in Set, drill bit dia. 35 mm, Total length 100 mm, shank dia. 12 mm	WD C 35x100 S2	66,85 80,22	<b>768164</b>
	for all Festool cordless drills and drills with keyless chuck, 15 - 20 - 25 - 30 and 35 mm diameter bits, 1 centring point CP-WD 2.5 x 14.5, 1 centering bit CB-WD 2.5 x 30, 1 ejector rod, 2 extensions A-WD M6 9 x 150 MAN and A-WD M8 12 x 150 MAN for hand drills, in a SYSTAINER MINI	WD C SETL 15-35 S2	292,75 351,30	<b>768096</b>
	for all cordless screwdrivers and drills with keyless chuck, 15 - 20 - 25 - 30 and 35 mm diameter bits, 1 centring point CP-WD 2.5 x 14.5, 1 centering bit CB-WD 2.5 x 30, 1 ejector rod, in a SYSTAINER MINI	WD C SET5 15-35 S2	266,80 320,16	<b>768124</b>

## Drilling and screwdriving

### System accessories







#### Accessories for ZOBO drilling system

		Type	RRP in £*	Order no.
	<b>Depth gauge</b> for ZOBO drill bits			
	for drill Ø 10-30 mm, shank dia. 9 mm, with grub screw din 913 with hexagon socket M6x6 / SW 3	DG-WD 9/30	56,60 67,92	<b>768117</b>
	for drill Ø 31-40 mm, shank dia. 12 mm, with grub screw din 913 with hexagon socket M6x5 / SW 3	DG-WD 12/40	56,60 67,92	<b>768524</b>
	<b>Guide extension</b> for ZOBO drill bits, Length 150 mm, gl with drill bit 215 mm			
	for shank Ø 9mm, for drill Ø 15-30 mm, spanner opening 10, shank dia. 9 mm	A-WD M6 9x150 MAN	25,20 30,24	<b>768525</b>
	for shank Ø 12mm, for drill Ø 31-50 mm, spanner opening 14, shank dia. 12 mm	A-WD M8 12x150 MAN	28,00 33,60	<b>768137</b>
	<b>Brad point</b> for ZOBO drill bits, dia. 2,5 mm, suitable for drill bit wd c Ø 10-50 mm, suitable for drill bit wd hw Ø 10-30 mm			
	effective length 3,5 mm	CP-WD 2,5x3,5	3,10 3,72	<b>768126</b>
	effective length 7,5 mm	CP-WD 2,5x7,5	4,70 5,64	<b>768128</b>
	effective length 14,5 mm	CP-WD 2,5x14,5	5,90 7,08	<b>768121</b>
	effective length 19,0 mm	CP-WD 2,5x19	6,55 7,86	<b>768123</b>

#### CENTROTEC other accessoires

		Type	RRP in £*	Order no.
	<b>Deburring countersink</b> qty. in pack 1 piece(s)			
	Diameter 2-8 mm	QLS D 2- 8 CE	22,75 27,30	<b>492520</b>
	for pre-counterboring and flush screwing, Diameter 5-15 mm	QLS D 5-15 CE	28,25 33,90	<b>492521</b>
	<b>Drill bit with depth stop</b> carbide, adjustable depth stop, Diameter 5 mm, qty. in pack 1 piece(s)	BTA HW D 5 CE	32,75 39,30	<b>492522</b>
	<b>Spare part drill bit</b> for drill bit with depth stop, carbide, Diameter 5 mm, qty. in pack 1 piece(s)	HW D 5 F.BTA	21,90 26,28	<b>491794</b>
	<b>Drill countersink with depth stop</b> adjustable depth stop, Diameter 3,5 mm, qty. in pack 1 piece(s)	BSTA HS D 3,5 CE	43,00 51,60	<b>492523</b>
	<b>Spare part drill bit</b> for drill countersink with depth stop, Diameter 3,5 mm, qty. in pack 5 piece(s)	EB-BSTA D 3,5/5	11,40 13,68	<b>494445</b>
	<b>Drill countersink with depth stop</b> adjustable depth stop, Diameter 4,5 mm, qty. in pack 1 piece(s)	BSTA HS D 4,5 CE	45,25 54,30	<b>492524</b>
	<b>Spare part drill bit</b> for drill countersink with depth stop, Diameter 4,5 mm, qty. in pack 5 piece(s)	EB-BSTA D 4,5/5	11,40 13,68	<b>494446</b>
	<b>Drill countersink with depth stop</b> adjustable depth stop, Diameter 5 mm, qty. in pack 1 piece(s)	BSTA HS D 5 CE	47,55 57,06	<b>496451</b>
	<b>Spare part drill bit</b> for drill countersink with depth stop, Diameter 5 mm, qty. in pack 5 piece(s)	EB-BSTA D 5/5	11,40 13,68	<b>496452</b>
	<b>Depth stop</b> spare sleeves for drill bits/countersinks with depth stop, qty. in pack 5 piece(s)	BTA/BSTA/5	51,74 62,08	<b>495882</b>
	<b>Centering bit</b> with depth stop for 5 mm Euro-screws, Diameter 5 mm, qty. in pack 1 piece(s)	ZB HS D 5 EURO CE	43,00 51,60	<b>492525</b>
	<b>Spare part drill bit</b> for centring bits, Diameter 5 mm, qty. in pack 1 piece(s)	HS D 5	16,10 19,32	<b>493572</b>
	<b>Hook driver</b> for all Festool cordless drills with FastFix interface, Diameter 18 mm, qty. in pack 1 piece(s)	HD D 18 CE	8,70 10,44	<b>492526</b>
	<b>Drill adapter</b> qty. in pack 1 piece(s)	BA-CE CENTROTEC	14,55 17,46	<b>496450</b>

### Guide systems for drilling

		Type	RRP in £*	Order no.
	<b>Drill stand for carpentry</b> for powerful drills, easy movement thanks to precise guide rods and bronze slide bearing in the guide block, positive stability due to the square base plate with precision-milled supporting surface, Two depth gauges, Two parallel gauges, Centering plate for drill bits Ø 8 to 28 mm, Adapter ring Ø 57 mm / 43 mm, clamp for attachment collar Ø57/Ø43 mm, in a carton			
	drill depth max. 240 mm, drill bit length max. 320 mm, weight 2,8 kg	GD 320	230,00 276,00	<b>768768</b>
	drill depth max. 380 mm, drill bit length max. 460 mm, weight 3,2 kg	GD 460	248,35 298,02	<b>768119</b>
	swivel-mounted drill depth max. 310 mm, drill bit length max. 460 mm, weight 3,7 kg	GD 460 A	324,20 389,04	<b>769042</b>
	<b>Staircase drilling system</b> precise hole depth due to adjustable depth gauge, The drills are fitted and removed very quickly due to the bayonet lock function, clamp, adapter for the staircase bits with the 9 mm Ø shank, gauge ring, insert for the angular frame, adapter plate, open-end spanner SW8 and SW10, pin key SW3, drill bit dia. 10-40 mm			
	for mains-operated drills and powerful cordless screwdrivers, staircase bits Ø 18-20-22-25-30 mm, centring tips: 2 x CP-WD 2.5x3.5; 1 x CP-WD 2.5x7.5; 1 x CP-WD 2.5x14.5, 1 ejector rod, in a SYSTAINER SYS 1 T-LOC	GD D10-40 A Set	823,25 987,90	<b>768098</b>
	for powerful drills, swivel-mounted, in a carton	GD D10-40 A	544,20 653,04	<b>768182</b>
	<b>Guide extension</b> for staircase bits, for ZOBO drill bits			
	for drill Ø 10-30 mm, shank dia. 9 mm	PL-GD D9 12x185	51,70 62,04	<b>769364</b>
	for drill Ø 31-41 mm, shank dia. 12 mm	PL-GD D12 12x110	35,30 42,36	<b>769365</b>

### Accessories for drywall screwdriver DWC

		Type	RRP in £*	Order no.
	<b>Drywall screws</b> AF 55-DWP/DWC, Diameter 3,9 mm in a carton			
	magazine-loaded, 1000 pc. fine thread, Length 25 mm	DWS C FT 3,9x25 1000x	25,30 30,36	<b>769142</b>
	magazine-loaded, 1000 pc. fine thread, Length 35 mm	DWS C FT 3,9x35 1000x	25,30 30,36	<b>769143</b>
	magazine-loaded, 1000 pc. coarse thread, Length 35 mm	DWS C CT 3,9x35 1000x	25,30 30,36	<b>769144</b>
	magazine-loaded, 1000 pc. coarse thread, Length 45 mm	DWS C CT 3,9x45 1000x	25,30 30,36	<b>769145</b>





## The Festool 18 Volt system

<b>CARVEX cordless pendulum jigsaws</b> PSC 420, PSBC 420	232
<b>Cordless plunge-cut saw</b> TSC 55	233
<b>Cordless drill</b> T 18+3	234
<b>Cordless hammer drill</b> BHC 18	235
<b>Cordless drills QUADRIVE,</b> DRC 18/4, <b>cordless impact drills QUADRIVE</b> PDC 18/4	236
<b>Cordless drywall screwdriver</b> DWC 18-2500, DWC 18-4500	237

## Designed with a new approach in mind.

The Festool 18 Volt system:

Full of power. Full of endurance. And full of ideas.



With the combination of 5.2 Ah high-performance battery packs and brushless EC-TEC motor. For battery-powered tools that have been consistently developed for providing power, speed and impact energy but at no time reduce the tool to pure force. Tools that resist the conventional race for more ampere hours and replace qualities such as bigger, further, faster with more intelligence, more efficiency and more precision. For tools that combine dynamism, convenience and efficiency. And in their development, the most important aspect was paramount right from the start – the person actually working with the tools.

**Discover the new aspects of the Festool 18 Volt system. When drilling, screwdriving, sawing. For a new generation of independence. For greater convenience and excellent working results.**



### The heart of the 18 V system:

The combination of 5.2 Ah high-performance battery packs and brushless EC-TEC motor combines all the advantages expected of a cordless tool. Intelligent power electronics ensure optimal power development with finely metered energy for more efficient use of each battery charge. The intelligent motor control automatically regulates the torque to thresholds, thus guaranteeing a longer service life. And the omission of the brush unit enables a more compact and lighter design for noticeably less tiring work.

### Rethinking for more precision and endurance:

The cordless plunge-cut saw TSC 55 with variable dual battery system.



### Rethinking for more comfort and effortless work.

The compact drill hammer BHC 18 with the best weight/performance ratio in the 18 V class.



### Rethinking for quicker working progress:

The drywall screwdriver DWC 18 with magazine attachment and innovative stop-and-go function for series screw connections.



### Rethinking for more flexibility:

The cordless drills QUADRIVE and T 18+3 with FastFix change attachments when drilling and screwdriving.



### A new way of thinking for more ergonomic and comfortable work:

The super-light pendulum jigsaw family CARVEX PSC 420 and PSB 420 with excellent curve control.



# New: PowerSelect

Attractive. Fair. And as individual as your trade.

Buy what's necessary and supplement where possible. The 18-volt PowerSelect gives you all the possibilities you need to put together your individual battery-powered tools for drilling, working with screws and sawing. As an attractive starter set with battery packs, charger and accessories; a plus version with battery packs and charger; or as a basic version without battery and charger devices, but with the possibility of using existing battery packs and purchasing battery packs and charger individually at a later date. And there's no 'buy-later' trap – because even the individually purchased battery packs or chargers are calculated fairly and are no more expensive than the plus version.





NEW

PowerSelect: The freedom to buy only what you need.  
And only when it's needed.

## BASIC

**Example: PowerSelect basic PDC**

Ideal for extending the existing 18-volt system. The basic version in a SYSTAINER.



## ENERGY

**Example: PowerSelect Energy PDC**

Expand at any time without extra costs. The 5.2 Ah high-performance battery pack and charger as buy-later offer for your 18-volt system.



## STARTER-SET

**Example: PowerSelect starter set PDC**

Open up. Switch on. Get started. The starter set includes two battery packs and a charger, as well as suitable accessories\* in a SYSTAINER.

\* Depending on the product, the starter set is available as a plus version with battery pack and charger or as part of a set with battery pack, charger and suitable system accessories.



## EXTRA SECURITY

A new way of thinking for more investment security!  
**NEW from 01.01.2015:** SERVICE all-inclusive also for battery packs and charger accessories.



## The Festool 18 Volt system

### CARVEX PSC 420 and PSBC 420 cordless pendulum jigsaws

Brushless EC-TEC motor for a long service life and a high level of efficiency



## CARVEX PSC / PSBC 420



### Easy to manage and mobile.

The CARVEX PSC 420 and PSBC 420 follow every move with millimetre precision. The pendulum jigsaws in the hand are extremely light and intuitive to operate. 3,800 strokes per minute ensure overwhelming force on straight lines when working.

### The cordless version of CARVEX – hard working and powerful.

- ▶ Particularly efficient with lithium-ion batteries
- ▶ Battery packs for drills from C and T series can be used
- ▶ Excellent behaviour in curves thanks to threefold saw blade guide and rigid lifter rod
- ▶ Simple handling thanks to the softgrip and ergonomic design

Technical data	PSC 420 Li 18	PSBC 420 Li 18
Battery voltage (V)	18	18
Stroke rate (min <sup>-1</sup> )	1500-3800	1000-3800
Pendulum cover adjustment in stages	4	4
Cutting depth in wood (mm)	120	120
Cutting depth in NF metals (mm)	20	20
Cutting depth in steel (soft) (mm)	10	10
Li-Ion battery capacity (Ah)	5,2	5,2
weight (kg)	2,4	2,4



= with MMC electronics

Items Included	RRP in £*	Order no.
2 saw blades, splinterguard, in a SYSTAINER SYS 2 T-LOC		
<b>PSC 420 EB Li-Basic</b> without battery pack, without charger, rubberised frame for battery packs	263,00 315,60	<b>561738</b>
<b>PSC 420 EB Li 18-Plus GB</b> TCL 3 charger, battery pack BPC 18 Li 5.2 Ah	382,00 458,40	<b>561747</b>
<b>PSBC 420 EB Li-Basic</b> without battery pack, without charger, rubberised frame for battery packs	263,00 315,60	<b>561739</b>
<b>PSBC 420 EB Li 18-Plus GB</b> TCL 3 charger, battery pack BPC 18 Li 5.2 Ah	382,00 458,40	<b>561751</b>

Find the entire Festool sawing range from page 6

\* Recommended retail price of manufacturer. Dealer prices may vary.  
Excl. VAT.  
Incl. VAT.

System accessories  
from page 30

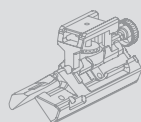

Jigsaw blades  
from page 38



## The Festool 18 Volt system

### Cordless plunge-cut saw TSC 55



Brushless EC-TEC motor for a long service life and a high level of efficiency

# TSC 55



#### Our best plunge-cut saw is now independent.

- ▶ Brushless EC-TEC motor combined with lithium-ion batteries for maximum cutting power
- ▶ Flexible dual battery concept: can be operated with two 18-volt battery packs (36V) for maximum power or one 18-volt battery pack for low weight
- ▶ High-speed EC-TEC motor for perfect cutting quality and rapid working progress
- ▶ Chip collection bag for clean, healthy working

#### Technical data

Battery voltage (V)	18/36
Idle engine speed (min <sup>-1</sup> )	2650-3800/5200
Saw blade diameter (mm)	160
Angular range (°)	-1-47
Cutting depth (mm)	0-55
Cutting depth at 45 degrees (mm)	0-43
Connection Ø d/e (mm)	27/36
Li-Ion battery capacity (Ah)	5,2
Weight 1x18V/2x18V (kg)	4,6/5,3



■ = with MMC electronics

Items Included	RRP in £*	Order no.
fine tooth saw blade HW W48, chip collection bag, splinterguard, Flag window; vision panel, operation tool, in a SYSTAINER SYS 5 T-LOC		
<b>TSC 55 REB Li-Basic</b> without battery pack, without charger	384,00 460,80	<b>561737</b>
<b>TSC 55 REB-Plus Li GB</b> spare battery pack lithium-ion 5.2 Ah, TCL 3 charger	580,00 696,00	<b>561713</b>

Find the entire Festool sawing range from page 6

\* Recommended retail price of manufacturer. Dealer prices may vary.  
Excl. VAT.  
Incl. VAT.

#### System accessories from page 31

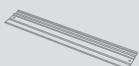

#### Saw blades from page 42



#### Precise and mobile.

Precise working instead of time-consuming reworking – with the cordless plunge-cut saw TSC 55. At a powerful 5,200 revolutions per minute. The flexible dual battery system ensures absolute mobility in use allowing you to forget about cables and sockets when working.

# The Festool 18 Volt system

## Cordless drill T 18+3



product  
design  
award

2009

Brushless EC-TEC motor for a long service life and a high level of efficiency



# T 18+3



### Brains meet brawn.

- ▶ Ideal ergonomics: compact, lightweight and perfectly balanced
- ▶ Brushless EC-TEC motor with integrated motor management for an extended service life and maximum power
- ▶ Fast change between applications with the CENTROTEC quick-change system and FastFix attachments; all bits can also be inserted into the direct bit holder
- ▶ Switch easily from fastening to drilling without changing the torque setting

#### Technical data

Battery voltage (V)	18
Gears	2
Idling speed, 1st gear/2nd gear (min <sup>-1</sup> )	0-450/0-1500
Drilling diameter, wood/steel	45/16
Torque adjustment (Nm)	0,5-8/0,5-6
Max. torque, wood/steel (Nm)	30/45
Chuck range (mm)	1,5-13
Li-Ion battery capacity (Ah)	5,2
Charging time Li Ion (min)	90
Weight with Li Ion (kg)	1,7



☐ = with electronics

#### Items Included

	RRP in £*	Order no.
CENTROTEC tool chuck, CENTROTEC bit holder, FastFix keyless chuck 13 mm, bit PZ 2, 49 x 98 x 71 yellow plastic container, 98 x 147 x 71 green plastic container, in a SYSTAINER SYS 2 T-LOC		
<b>T 18+3 Li-Basic</b> without battery pack, without charger	187,00 224,40	<b>564605</b>
<b>T 18+3 Li 5,2-Plus GB</b> TCL 3 charger, spare battery pack lithium-ion 5.2 Ah	383,00 459,60	<b>564569</b>

Find the entire Festool drilling and screw-driving range from page 198

### Flexible and mobile.

The T 18+3 is involved in every job without any work interruptions. With the lightweight and compact CENTROTEC quick-change system, you can quickly and easily replace the chuck and bit holder.

\* Recommended retail price of manufacturer. Dealer prices may vary.  
Excl. VAT.  
Incl. VAT.

#### System accessories from page 214

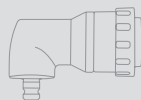

#### Screwdriver and drill bits from page 218



## The Festool 18 Volt system

### Cordless hammer drill BHC 18



Brushless EC-TEC motor for a long service life and a high level of efficiency

# BHC 18



06



### The most powerful compact hammer drill

- ▶ Unbeatable power to weight ratio thanks to the combination of EC-TEC motor
- ▶ Vibration damping for effortless work; maximum working comfort in all work situations
- ▶ Brushless EC-TEC motor with integrated motor management for long service life and the highest output
- ▶ High-quality lithium-ion battery technology for the longest sustained usage

#### Technical data

Battery voltage (V)	18
Gears	1
Idle engine speed (min <sup>-1</sup> )	0-1100
Max. number of strokes (min <sup>-1</sup> )	4895
Drilling Ø (beton) (mm)	18
Crown borer Ø (mm)	68
Single impact energy (J (EPTA))	1,8
Dimensions (L x W x H) (mm)	280 x 88 x 237
Li-Ion battery capacity (Ah)	5,2
Charging time Li Ion (min)	90
Weight with Li Ion (kg)	2,6



☐ = with electronics

Items Included	RRP in £*	Order no.
additional side-mounted hand grip, depth stop, in a SYSTAINER SYS 2 T-LOC		
<b>BHC 18 Li-Basic</b>	258,00	<b>564606</b>
without battery pack, without charger, 2x rubberised frame for battery packs	309,60	
<b>BHC 18 Li 5,2 GB</b>	454,00	<b>564589</b>
TCL 3 charger, spare battery pack lithium-ion 5.2 Ah incl. rubberised frame	544,80	

Find the entire Festool drilling and screw-driving range from page 198

\* Recommended retail price of manufacturer. Dealer prices may vary.  
Excl. VAT.  
Incl. VAT.

#### System accessories from page 215



#### Hammer drills from page 222



### Lightweight and mobile.

With the BHC 18 you save energy and can work effortlessly. With extremely high impact energy and integrated vibration damping, which absorbs the impact energy before it is transferred to the hands, the BHC 18 sits easily and smoothly in the hand.

## The Festool 18 Volt system

Cordless drills QUADRIVE DRC 18/4 and  
cordless impact drills QUADRIVE PDC 18/4

Brushless EC-TEC motor for  
a long service life and a high  
level of efficiency



# QUADRIVE DRC 18/4 / PDC 18/4



### The compact tool with impressive rotary power.

- ▶ Brushless EC-TEC motor combined with high-quality lithium-ion battery technology for up to 100% greater fastening capacity and longer service life
- ▶ 4-speed gearbox capable of 3800 rpm for rapid, clean drilling results
- ▶ Universal solution for fastening operations that require high torque and for drilling large diameter holes
- ▶ Axial impact feature (PDC) that can be deactivated for drilling in brickwork

Technical data	DRC 18/4 Li-Basic	PDC 18/4 Li-Basic
Battery voltage [V]	18	18
Gears	4	4
Idling speed, 1st gear/2nd gear [min <sup>-1</sup> ]	0-400/0-850	0-400/0-850
Idling speed, 3rd/4th gear [min <sup>-1</sup> ]	0-1850/0-3800	0-1850/0-3800
Max. torque, wood/steel [Nm]	40/60	40/60
Max. number of strokes [min <sup>-1</sup> ]		76000
Drilling #d# [wood/steel] [mm]	50/12	50/12
Drilling diameter in brickwork [mm]		10
Weight with Li Ion [kg]	1,8	1,9
Chuck range [mm]	1,5-13	1,5-13
Li-Ion battery capacity [Ah]	5,2	5,2



= with electronics

Items Included	RRP in £*	Order no.
CENTROTEC tool chuck, CENTROTEC bit holder, bit PZ 2, FastFix keyless chuck 13 mm, additional side-mounted hand grip, in a SYSTAINER SYS 2 DF T-LOC		
<b>DRC 18/4 Li-Basic</b> without battery pack, without charger, rubberised frame for battery packs	235,00 282,00	<b>500782</b>
<b>DRC 18/4 Li 5,2-Plus GB</b> TCL 3 charger, spare battery pack lithium-ion 5.2 Ah incl. rubberised frame	431,00 517,20	<b>564585</b>
<b>PDC 18/4 Li-Basic</b> without battery pack, without charger, rubberised frame for battery packs	244,00 292,80	<b>500781</b>
<b>PDC 18/4 Li 5,2-Plus GB</b> TCL 3 charger, spare battery pack lithium-ion 5.2 Ah incl. rubberised frame	440,00 528,00	<b>564580</b>

### Sturdy and mobile.

The QUADRIVE DRC and PDC are tough performers with excellent staying power. With the sturdy 4-speed metal transmission, you have 4 gears for every work situation. The 60 Nm torque ensures powerful screwdriving in 1st gear and precise drilling in 4th gear at 3,800 rpm.

Find the entire Festool drilling and screw-driving range from page 198

\* Recommended retail price of manufacturer. Dealer prices may vary.  
Excl. VAT.  
Incl. VAT.

System accessories  
from page 216



Screwdriver and drill bits  
from page 218



## The Festool 18 Volt system

### Cordless drywall screwdriver DURADRIVE DWC 18



Brushless EC-TEC motor for a long service life and a high level of efficiency

## DURADRIVE DWC 18

### Power and durability for interior work.

- ▶ Precision, wear-free electronic switch-off function for accurate insertion depths and a long service life
- ▶ Energy-saving function for machine start/stop without actuating the main switch
- ▶ Robust, brushless EC motor for maximum efficiency and durability
- ▶ Lightweight and perfectly balanced for non-tiring work

Technical data	DWC 18-2500	DWC 18-4500
	5,2 Li	5,2 Li
Battery voltage (V)	18	18
Gears	1	1
Idle engine speed (min <sup>-1</sup> )	0-2500	0-4500
Max. torque, wood/steel (Nm)	7/18	5/14
Tool reception	1/4"	1/4"
Li-Ion battery capacity (Ah)	5,2	5,2
Weight with depth stop (kg)	1,9	1,9
Weight with magazine attachment (kg)	2,1	2,1



■ = with electronics

Items Included	RRP in £*	Order no.
magazine attachment, depth stop, belt clip, scaffolding holder, magnetic bit holder, 2 bit PH2, long, in a SYSTAINER SYS 2 T-LOC		
<b>DWC 18-2500 Li-Basic</b>	281,00	<b>564607</b>
without battery pack, without charger, rubberised frame for battery packs	337,20	
<b>DWC 18-4500 Li-Basic</b>	281,00	<b>564608</b>
without battery pack, without charger, rubberised frame for battery packs	337,20	
<b>DWC 18-2500 5,2 Li-Plus GB</b>	476,00	<b>564591</b>
TCL 3 charger, spare battery pack lithium-ion 5.2 Ah incl. rubberised frame	571,20	
<b>DWC 18-4500 5,2 Li-Plus GB</b>	476,00	<b>564593</b>
TCL 3 charger, spare battery pack lithium-ion 5.2 Ah incl. rubberised frame	571,20	

Find the entire Festool drilling and screw-driving range from page 198

\* Recommended retail price of manufacturer. Dealer prices may vary.  
Excl. VAT.  
Incl. VAT.

System accessories  
from page 217



06



### Innovative and mobile.

The DURADRIVE DWC 18 allows you to make series screw connections comfortably and as efficiently as possible. The innovative stop-and-go function ensures up to 40% higher performance per battery charge.







## DOMINO joining system

Overview of products and applications 240

DOMINO joining machines DF 500, DF 700 242

Accessories and consumable materials 244

The Festool system

# DOMINO joining system

## Overview of products and applications

Page 242 ————— 243

The DOMINO system: Perfect for panel, frame and rack joints as well as narrow, wide, delicate and bulky workpieces. Dowel diameters ranging from 4 to 14 mm for unlimited jointing possibilities.

**DF 500**

**DF 700**



### Applications

### DOMINO joining machines

#### Joining boards

Drawers, Ø 4 mm dowels or larger	<input checked="" type="radio"/>	<input type="radio"/>
Cabinet with Ø 5 and 6 mm dowels	<input checked="" type="radio"/>	<input type="radio"/>
Solid wood furniture with Ø 8 and 10 mm dowels	<input checked="" type="radio"/>	<input type="radio"/>
Solid wood furniture (e.g. beds) with Ø 12 and 14 mm dowels	<input type="radio"/>	<input checked="" type="radio"/>

#### Rack joints

Lightweight frame construction (e.g. chairs) up to Ø 10 mm dowels	<input checked="" type="radio"/>	<input type="radio"/>
Stable frame construction (e.g. tables) with Ø 10 to 14 mm dowels	<input type="radio"/>	<input checked="" type="radio"/>
Frame and base structures	<input type="radio"/>	<input checked="" type="radio"/>

#### Frame joints

Furniture fronts with framework construction with Ø 8 and 10 mm dowels	<input checked="" type="radio"/>	<input type="radio"/>
Solid wood furniture with frame design	<input type="radio"/>	<input checked="" type="radio"/>
House doors and internal doors	<input type="radio"/>	<input checked="" type="radio"/>

#### Other applications

Joining thin strips, width 25 mm or more.	<input checked="" type="radio"/>	<input type="radio"/>
Joining round poles with the handrail fence.	<input checked="" type="radio"/>	<input type="radio"/>
Connecting wide cornices (e.g. solid wood panels)	<input checked="" type="radio"/>	<input checked="" type="radio"/>

**Extremely appropriate**

**Appropriate**

#### Technical data

Power consumption (W)	420	720
Max. routing depth (mm)	28	70
DOMINO slot cutter Ø (mm)	4, 5, 6, 8, 10	8, 10, 12, 14
Routing height adjustment (mm)	5-30	10-50
Mitre routing (°)	0-90	0-90
Weight (kg)	3,2	5,2

Every wooden joint has its advantages.  
The DOMINO joining system combines them all.



### The DOMINO long-hole principle.

Custom-fit alignment: The first DOMINO is positioned in a precision cut elongated hole, the next DOMINOS are inserted into wider holes with play so that the joint can be aligned effortlessly. The result is a stable joint, rotation-proof from the first dowel.

### Impressive time savings.

No complicated adjustments or measurements: with integral stop pins for positioning the machine quickly and accurately. It is easy to adapt the routing height and depth to different material thicknesses. When making solid joints, you can save up to half the time with the DOMINO XL.

### Enormous variety of applications.

Two machines, dowel sizes ranging from 4 to 14 mm in diameter, flexible adjustment options and compatible system accessories offer virtually unlimited joining possibilities. Even narrow strip material and round poles are easy to join.



#### Beechwood DOMINO dowel

Bear the Pan European Forest Council (PEFC) quality seal for wood products originating from sustainable, well-maintained, responsible forest cultivation.



#### Hardwood DOMINO dowel

Are weatherproof and resistant to insects and mould, making them ideal for outdoor applications. They are manufactured from wood from sustainably managed and monitored forests.

## DOMINO joining system

DOMINO DF 500 joining machine



product  
design  
award

2006



# DOMINO DF 500



### A system that joins everything up.

The DOMINO DF 500 is particularly handy and offers almost unlimited jointing possibilities. No matter whether it is panel or cabinet construction, for lightweight frame or rack joints – the DF 500 impresses with maximum precision and simple handling.

### More precise joints.

- ▶ Diverse use with dowels from 4 x 20 mm to 10 x 50 mm
- ▶ Patented routing principle unique to hand-held machines for accurate work with no kickbacks
- ▶ Stops that are quick and easy to adjust, for accurate results
- ▶ Ergonomic shape for ease of operation in any position

#### Technical data

Power consumption (W)	420
Idle engine speed (min <sup>-1</sup> )	24300
Depth stop for routing depth (mm)	12, 15, 20, 25, 28
Max. milling depth (mm)	28
DOMINO slot cutter Ø (mm)	4, 5, 6, 8, 10
Routing height adjustment (mm)	5-30
Mitre routing [°]	0-90
Connection Ø d/e (mm)	27
weight (kg)	3,2



Items Included	RRP in £*	Order no.
DOMINO cutter D5, support bracket, operation tool, in a SYSTAINER SYS 2 T-LOC		
<b>DF 500 Q-Plus GB 240V</b>	624,00 748,80	<b>574327</b>
<b>DF 500 Q-Plus GB 110V</b>	624,00 748,80	<b>574329</b>
<b>DF 500 Q-Set GB 240 V</b> trim stop, cross stop	677,00 812,40	<b>574429</b>

\* Recommended retail price of manufacturer. Dealer prices may vary.  
Excl. VAT.  
Incl. VAT.

#### System accessories from page 246

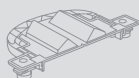

#### DOMINOs from page 246



# DOMINO joining system

## DOMINO XL DF 700 joining machine



product design award

2012

# DOMINO XL DF 700



### The quickest way to join large workpieces.

Comes to the workpiece and not vice versa: DOMINO XL. Quick, simple, precise and extremely stable – with measurably shorter tooling times and up to 50% time-saving in comparison to stationary machines. The DOMINO XL is therefore ideally suited for furniture and door construction and solid wood joints.

### Extra mobile. Extra stable.

- ▶ Maximum stability of joints up to a dowel size of 14 x 140 mm
- ▶ Patented routing principle unique to hand-held machines for accurate work with no kickbacks
- ▶ Saves more time compared to a stationary machine
- ▶ Stops that are quick and easy to adjust, for accurate results

#### Technical data

Power consumption (W)	720
Idle engine speed (min <sup>-1</sup> )	21000
Depth stop for routing depth (mm)	15-70
Max. milling depth (mm)	70
DOMINO slot cutter Ø (mm)	8, 10, 12, 14
Routing height adjustment (mm)	10-50
Mitre routing (°)	0-90
Connection Ø d/e (mm)	27
weight (kg)	5,2



☐ = with electronics

#### Items Included

DOMINO cutter D 12, support bracket, 2x dowel box, operation tool, in a SYSTAINER SYS 5 T-LOC

	RRP in £*	Order no.
<b>DF 700 EQ-Plus GB 240V</b>	846,00 1.015,20	<b>574420</b>

\* Recommended retail price of manufacturer. Dealer prices may vary.  
Excl. VAT.  
Incl. VAT.

#### System accessories from page 248

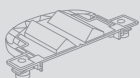

#### DOMINOs from page 248



### The Festool system.

Because things work better when everything fits together:  
The DOMINO jointing system offers the right dowels and cutters  
for every application. Even complicated shapes are easy to join  
using different stops compatible with both DOMINO jointers.

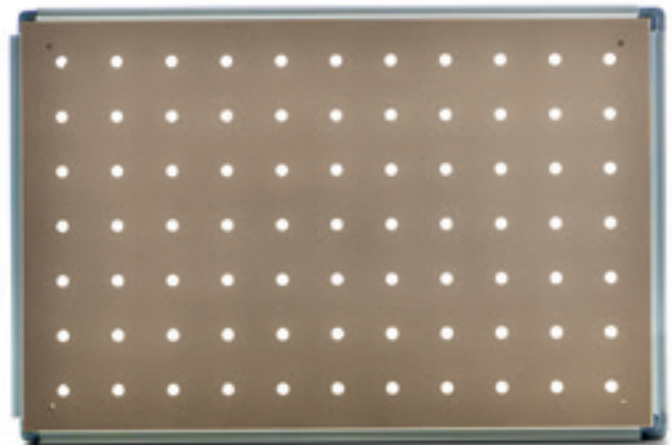

## DOMINO joining system

Accessories and consumable materials



# DOMINO joining system

## System accessories

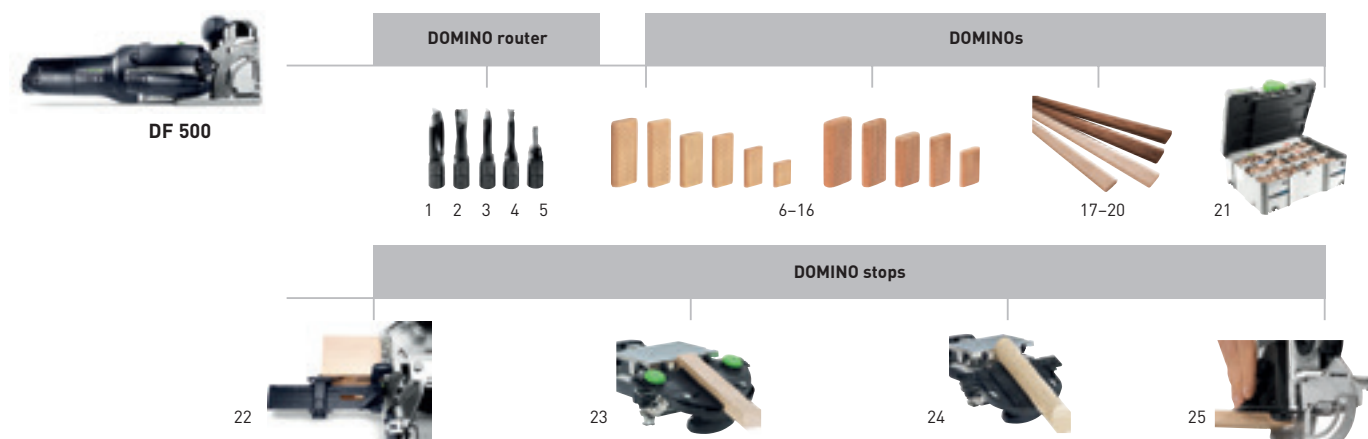

### Accessories for DOMINO DF 500 joining machine

Denomination	Explanation	RRP in £*	Order no.
1 Router D 4-NL 11 HW-DF 500	D 4 mm, NL 11 mm, in self-service display pack	28,80 34,56	495663
2 Router D 5-NL 20 HW-DF 500	D 5 mm, NL 20 mm, in self-service display pack	24,55 29,46	493490
3 Router D 6-NL 28 HW-DF 500	D 6 mm, NL 28 mm, in self-service display pack	25,00 30,00	493491
4 Router D 8-NL 28 HW-DF 500	D 8 mm, NL 28 mm, in self-service display pack	26,20 31,44	493492
5 Router D 10-NL 28 HW-DF 500	D 10 mm, NL 28 mm, in self-service display pack	29,40 35,28	493493
6 Beechwood dowel D 5x30/1800 BU	dimensions 5x30 mm, qty. in pack 1800 piece(s), in a carton	61,30 73,56	493296
7 Beechwood dowel D 6x40/1140 BU	dimensions 6x40 mm, qty. in pack 1140 piece(s), in a carton	61,30 73,56	493297
8 Beechwood dowel D 8x40/780 BU	dimensions 8x40 mm, qty. in pack 780 piece(s), in a carton	61,30 73,56	493298
9 Beechwood dowel D 8x50/600 BU	dimensions 8x50 mm, qty. in pack 600 piece(s), in a carton	61,30 73,56	493299
10 Beechwood dowel D 10x50/510 BU	dimensions 10x50 mm, qty. in pack 510 piece(s), in a carton	61,30 73,56	493300
11 Beechwood dowel D 4x20/450 BU	dimensions 4x20 mm, qty. in pack 450 piece(s), in self-service display pack	11,40 13,68	495661
12 Beechwood dowel D 5x30/300 BU	dimensions 5x30 mm, qty. in pack 300 piece(s), in self-service display pack	11,40 13,68	494938
13 Beechwood dowel D 6x40/190 BU	dimensions 6x40 mm, qty. in pack 190 piece(s), in self-service display pack	11,40 13,68	494939
14 Beechwood dowel D 8x40/130 BU	dimensions 8x40 mm, qty. in pack 130 piece(s), in self-service display pack	11,40 13,68	494940
15 Beechwood dowel D 8x50/100 BU	dimensions 8x50 mm, qty. in pack 100 piece(s), in self-service display pack	11,40 13,68	494941
16 Beechwood dowel D 10x50/85 BU	dimensions 10x50 mm, qty. in pack 85 piece(s), in self-service display pack	11,40 13,68	494942
17 DOMINO beechwood D 8x750/36 BU	dimensions 8x750 mm, qty. in pack 36 piece(s), in a carton	45,10 54,12	498686
18 DOMINO beechwood D 10x750/28 BU	dimensions 10x750 mm, qty. in pack 28 piece(s), in a carton	43,90 52,68	498687
19 DOMINO Sipo D 8x750/36 MAU	dimensions 8x750 mm, qty. in pack 36 piece(s), in a carton	87,75 105,30	498690
20 DOMINO Sipo D 10x750/28 MAU	dimensions 10x750 mm, qty. in pack 28 piece(s), in a carton	85,05 102,06	498691



**Accessories for DOMINO DF 500 joining machine**

Denomination	Explanation	RRP in £*	Order no.
<b>21 Beechwood dowel range DS 4/5/6/8/10 1060x BU</b>	DOMINO 4x20, 5x30, 6x40, 8x40, 8x50, 10x50 mm and DOMINO cutters for sizes 4, 5, 6, 8 and 10, dimensions 396 x 296 x 157,5 mm, qty. in pack 1060 piece(s), in a SYSTAINER SYS 2 T-LOC	170,00 204,00	<b>498899</b>
<b>Assortment SYS SORT-SYS DOMINO</b>	empty systainer SYS 2 T-LOC with dividers for DOMINOs	55,00 66,00	<b>497703</b>
<b>22 Cross stop QA-DF 500/700</b>	for DF 500 and DF 700, items included: a left and right cross stop, for repeat hole spacing between 100 and 205 mm, for precise positioning of the workpieces with edge clearance of 100-205 mm, in self-service display pack	38,95 46,74	<b>498590</b>
<b>23 Trim stop LA-DF 500/700</b>	for DF 500 and DF 700, for strip material with widths between 22 and 70 mm, qty. in pack 1 piece(s), in self-service display pack	37,50 45,00	<b>493487</b>
<b>24 Handrail fence RA DF 500/700</b>	for DF 500 and DF 700, for round wooden poles, dia. 35 – 60 mm, for precise routing of round poles Ø 35 – 60 mm, in self-service display pack	31,35 37,62	<b>494847</b>
<b>25 Additional stop ZA-DF 500</b>	for DF 500, support widener and side stop, for reducing the dowel centre from 37 mm to 20 mm, for secure positioning of the router, in a carton	18,55 22,26	<b>495666</b>

# DOMINO joining system

## System accessories



DF 700

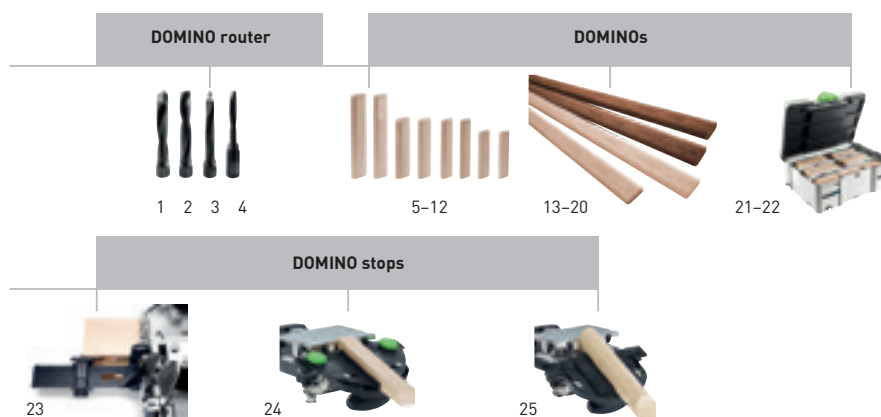

### Accessories for DOMINO XL DF 700 joining machine

Denomination	Explanation	RRP in £*	Order no.
1 <b>DOMINO router D 8-NL 50 HW-DF 700</b>	routing tools with threaded supports for the DOMINO joining machine XL DF 700, D 8 mm, NL 50 mm, in self-service display pack	34,90 41,88	<b>497868</b>
2 <b>DOMINO router D 10-NL 70 HW-DF 700</b>	routing tools with threaded supports for the DOMINO joining machine XL DF 700, D 10 mm, NL 70 mm, in self-service display pack	37,15 44,58	<b>497869</b>
3 <b>DOMINO router D 12-NL 70 HW-DF 700</b>	routing tools with threaded supports for the DOMINO joining machine XL DF 700, D 12 mm, NL 70 mm, in self-service display pack	38,95 46,74	<b>497870</b>
4 <b>DOMINO router D 14-NL 70 HW-DF 700</b>	routing tools with threaded supports for the DOMINO joining machine XL DF 700, D 14 mm, NL 70 mm, in self-service display pack	41,70 50,04	<b>497871</b>
5 <b>DOMINO D 8x80/190 BU</b>	dimensions 8x80 mm, qty. in pack 190 piece(s), in a carton	31,30 37,56	<b>498212</b>
6 <b>DOMINO D 8x100/150 BU</b>	dimensions 8x100 mm, qty. in pack 150 piece(s), in a carton	31,30 37,56	<b>498213</b>
7 <b>DOMINO D 10x80/150 BU</b>	dimensions 10x80 mm, qty. in pack 150 piece(s), in a carton	31,30 37,56	<b>498214</b>
8 <b>DOMINO D 10x100/120 BU</b>	dimensions 10x100 mm, qty. in pack 120 piece(s), in a carton	31,30 37,56	<b>498215</b>
9 <b>DOMINO D 12x100/100 BU</b>	dimensions 12x100 mm, qty. in pack 100 piece(s), in a carton	31,30 37,56	<b>498216</b>
10 <b>DOMINO D 12x140/90 BU</b>	dimensions 12x140 mm, qty. in pack 90 piece(s), in a carton	31,30 37,56	<b>498217</b>
11 <b>DOMINO D 14x100/80 BU</b>	dimensions 14x100 mm, qty. in pack 80 piece(s), in a carton	31,30 37,56	<b>498218</b>
12 <b>DOMINO D 14x140/70 BU</b>	dimensions 14x140 mm, qty. in pack 70 piece(s), in a carton	31,30 37,56	<b>498219</b>
13 <b>DOMINO beechwood D 8x750/36 BU</b>	dimensions 8x750 mm, qty. in pack 36 piece(s), in a carton	45,10 54,12	<b>498686</b>
14 <b>DOMINO beechwood D 10x750/28 BU</b>	dimensions 10x750 mm, qty. in pack 28 piece(s), in a carton	43,90 52,68	<b>498687</b>
15 <b>DOMINO beechwood D 12x750/22 BU</b>	dimensions 12x750 mm, qty. in pack 22 piece(s), in a carton	41,30 49,56	<b>498688</b>
16 <b>DOMINO beechwood D 14x750/18 BU</b>	dimensions 14x750 mm, qty. in pack 18 piece(s), in a carton	41,30 49,56	<b>498689</b>
17 <b>DOMINO Sipo D 8x750/36 MAU</b>	dimensions 8x750 mm, qty. in pack 36 piece(s), in a carton	87,75 105,30	<b>498690</b>
18 <b>DOMINO Sipo D 10x750/28 MAU</b>	dimensions 10x750 mm, qty. in pack 28 piece(s), in a carton	85,05 102,06	<b>498691</b>
19 <b>DOMINO Sipo D 12x750/22 MAU</b>	dimensions 12x750 mm, qty. in pack 22 piece(s), in a carton	82,45 98,94	<b>498692</b>
20 <b>DOMINO Sipo D 14x750/18 MAU</b>	dimensions 14x750 mm, qty. in pack 18 piece(s), in a carton	82,45 98,94	<b>498693</b>

**Accessories for DOMINO XL DF 700 joining machine**

Denomination	Explanation	RRP in £*	Order no.
<b>21 Beechwood DOMINO XL assortment DS/XL D8/D10 306x BU</b>	for DOMINO XL, dowel range, DOMINOs 8x50, 8x80, 8x100, 10x50, 10x80, 10x100 and DOMINO XL cutter for sizes 8 and 10, qty. in pack 306 piece(s), in a SYSTAINER SYS 2 T-LOC	152,00 182,40	<b>498204</b>
<b>22 Beechwood DOMINO XL assortment DS/XL D12/D14 128x BU</b>	for DOMINO XL, dowel range, DOMINO 12x100, 12x140, 14x100, 14x140 and DOMINO XL cutter for size 14, qty. in pack 128 piece(s), in a SYSTAINER SYS 2 T-LOC	131,20 157,44	<b>498205</b>
<b>23 Cross stop QA-DF 500/700</b>	for DF 500 and DF 700, items included: a left and right cross stop, for repeat hole spacing between 100 and 205 mm, for precise positioning of the workpieces with edge clearance of 100-205 mm, in self-service display pack	38,95 46,74	<b>498590</b>
<b>24 Trim stop LA-DF 500/700</b>	for DF 500 and DF 700, for strip material with widths between 22 and 70 mm, qty. in pack 1 piece(s), in self-service display pack	37,50 45,00	<b>493487</b>
<b>25 Handrail fence RA DF 500/700</b>	for DF 500 and DF 700, for round wooden poles, dia. 35 – 60 mm, for precise routing of round poles Ø 35 – 60 mm, in self-service display pack	31,35 37,62	<b>494847</b>



## Edging

**Overview of products and applications** 252

**CONTURO edge bander** CONTURO KA 65, KP 65/2 254

**Semi-stationary edge banding** AP-KA 65, MFT/3 CONTURO 256

**Accessories and consumable materials** 258

The Festool system

# Edging

## Overview of products and applications

Edging curves, radii, convex and concave shapes is easy with the CONTURO. Even mitred edges can be cut to an outstanding quality with the stationary unit. Quick, easy and clean – ideal for shaped parts and small batches. Suitable for machining all types of wood, plastic or melamine edging with a height of 18-65 mm and edge strength of 0.5-3.0 mm (depending on material). The CONTURO is packed away safely in a SYSTAINER, extremely mobile and delivers a perfect edge quality, even in combination with system accessories.

Page 254 ————— 257

KA 65

MFT/3 CONTURO



**CONTURO**  
edge bander

**Semi-stationary**  
edge banding

### Applications

#### Gluing with the edge bander

Affixing straight edging	<input checked="" type="radio"/>	<input type="radio"/>
Edging concave and convex moulded parts	<input checked="" type="radio"/>	<input type="radio"/>
Gluing circular sections	<input checked="" type="radio"/>	<input type="radio"/>
Edging inner corners	<input checked="" type="radio"/>	<input type="radio"/>

#### Stationary gluing of edges

Affixing narrow and straight edging	<input checked="" type="radio"/>	<input checked="" type="radio"/>
Affixing wide and straight edging	<input checked="" type="radio"/>	<input checked="" type="radio"/>
Edging small moulded parts	<input checked="" type="radio"/>	<input checked="" type="radio"/>
Edging mitre joints	<input checked="" type="radio"/>	<input checked="" type="radio"/>

Extremely appropriate  Appropriate

### Technical data

Power consumption (W)	1200
Edge height (mm)	18-65
Edge thickness (mm)	0,5-3,0
Inner radius (mm)	> 50
Warm-up time (min)	8
Melting temperature (°C)	100-210
Infeed speed (m/min)	2/4
Safety class	I
Weight (kg)	7,9



WORKING WITH MFT



WORKING WITH THE VAC SYS



PREPARING THE WORKPIECE



PERFECT EDGE FINISH

# SYSTEM

## The perfect edge. The CONTURO in a system.

At the heart of the system, the CONTURO is responsible for the gluing process while the surrounding system components perform all other working steps. From cutting and milling chipboard to size or applying glue, pressing down edging, cutting and flush trimming, smoothing and polishing – the Festool system operates with a level of professionalism and clean quality that only bench-mounted machines can achieve.



# CONTURO

GLUING EDGING

08



ADHESIVES



TRIMMING EDGING



SPECIAL ACCESSORIES



STATIONARY TASKS

# ACCESSORIES

## Edging

Edge bander CONTURO KA 65



# CONTURO KA 65



### The basis for the perfect edge.

Versatile and easy to operate, the CONTURO represents a genuine solution for manufacturing individual moulded parts, as well as affixing edging to workpieces or furniture components produced in small batches. Packed in a SYSTAINER, the CONTURO is also suitable for mobile use as well as manufacturing edging in situ with a perfect quality finish.

### The start of the perfect edge.

- ▶ Easy, clean and efficient working progress and patented cartridge gluing system for quick colour changes
- ▶ Precision glue application for a perfect join quality and maximum adhesion
- ▶ Nozzle system that is easy to clean, machine housing does not heat up, allowing safe working progress
- ▶ Adhesive melts according to requirements and does not boil, discolour or deteriorate

#### Technical data

Power consumption (W)	1200
Edge height (mm)	18-65
Edge thickness (mm)	0,5-3,0
Inner radius (mm)	> 50
Heating time (min)	8
Melting temperature (°C)	100-210
Feed speed (m/min)	2/4
Safety class	I
weight (kg)	7,9



Items Included	RRP in £*	Order no.
front handle, 4x natural EVA adhesive, in a SYSTAINER SYS 4 T-LOC		
<b>KA 65 Plus GB 240V</b>	1.865,00 2.238,00	<b>574606</b>
<b>KA 65 Set GB 240V</b> edge trimming set SYS KB-KA 65	2.083,00 2.499,60	<b>574614</b>

\* Recommended retail price of manufacturer. Dealer prices may vary.  
Excl. VAT.  
Incl. VAT.

#### System accessories from page 260







# KP 65/2



### The precise cut:

- ▶ Ergonomic handle location for easy, effortless trimming, even on thick edging
- ▶ Patented eccentric fine adjustment for precision impact trimming
- ▶ Tabletop on both sides of the trimming machine allows the user to trim left and right panel edges from above – with a perfect view of the workpiece
- ▶ Impact trimming function (for round table) and trimming of panel edges (final trimming) with a single machine

#### Technical data

Trimming height (mm)	65
Trimming thickness (mm)	2

Items Included	RRP in £*	Order no.
in a carton		
<b>KP 65/2</b>	121,10 145,32	<b>499896</b>

### Flush trimming.

The protruding edging is trimmed with the Festool trimming machine KP 65/2: Insert the edge band between the trimming blades, move the trimming machine up to the stop pin, position parallel to the workpiece and press the handles together.

\* Recommended retail price of manufacturer. Dealer prices may vary.  
Excl. VAT.  
Incl. VAT.

## Edging

Adapter plate AP-KA 65



# AP-KA 65

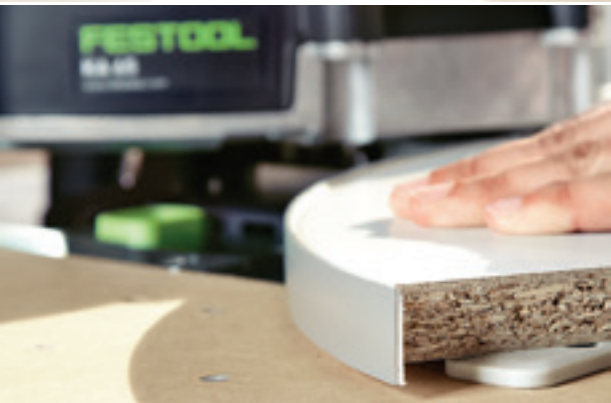

### Stationary gluing.

Stationary work with the CONTURO. Not a problem! With the adapter plate AP-KA 65. This allows not only the trimming of straight edges and curves, but also slanted edges at 90°-45° angles.

### Swivel-mounted stationary edging.

- ▶ For mounting the edge bander on a workbench
- ▶ Installation of adapter plate in a self-constructed table frame or in intended MFT perforated board
- ▶ For small batches, straight edges, free form elements and gluing inclined edges, angle from 0-47°

#### Technical data

Dimensions length x width (mm)	254 x 420
Min. installation height (mm)	150
Cutting angle adjustment (°)	0-47

Items Included	RRP in £*	Order no.
mounting plate for edge bander complete with 15 sliding guides, additional roll, in a carton		
<b>AP-KA 65</b>	259,65 311,58	<b>500175</b>

\* Recommended retail price of manufacturer. Dealer prices may vary.  
Excl. VAT.  
Incl. VAT.



## MFT/3 CONTURO

**1 table. 1000 possibilities.**

- ▶ For mounting the edge bander on a workbench
- ▶ Sliding guides for guiding the workpiece safely
- ▶ Allows the user to swivel the machine (0-47°) in the bench and position the workpiece horizontally during edging – for convenient and safe guidance, even with larger objects

**Technical data**

Table dimensions (mm)	1157 x 773
Work height (mm)	900
Swivel-mounted edge bander (°)	47
weight (kg)	29

Items Included	RRP in £*	Order no.
adapter plate AP-KA 65, cross brace QT-MFT/3, in a carton		
<b>MFT/3 Conturo</b>	611,45 733,74	<b>500869</b>

\* Recommended retail price of manufacturer. Dealer prices may vary.  
Excl. VAT.  
Incl. VAT.

**Stationary unit for edge banding**

Stationary edging? Yes, with the MFT/3 CONTURO – a special multifunction table for the CONTURO KA 65. Simply insert the edge bander in the multifunction table MFT/3 CONTURO via an adapter plate. As a result, not only straight edges and curves can be trimmed, but also sloping edges. The CONTURO KA 65 can be swivel-mounted in the stationary unit from 90° – 45°.

### **The Festool system.**

As the basis for the perfect edge, the CONTURO assumes the gluing process. Its system completes all the other steps. From the glue application, pressing the edges, trimming to smoothing down and polishing – the Festool system makes everything possible in an equally professional and clean quality which was previously only possible with bench-mounted machines.



## Edging

Accessories and consumable materials

System accessories

260



# Edging

## System accessories



### Accessories for edge bander CONTURO KA 65

Denomination	Explanation	RRP in €*	Order no.
<b>1 Additional roll ZR-KA 65</b>	for KA 65, for affixing edging to tight curves and shaped parts, offers additional pressure point for applying more pressure on the edge of the board when glued, roll height 65 mm, in self-service display pack	48,00 57,60	<b>499480</b>
<b>2 Scratch protector LAS-STF-KA 65</b>	for KA 65, for using the edge bander on delicate or high-gloss surfaces, 4x retaining screws, 3x felt pads, in self-service display pack	23,15 27,78	<b>499892</b>
<b>Spare felt EF-LAS-STF-KA 65 10x</b>	for scratch protector LAS-STF-KA 65, for using the edge bander on delicate or high-gloss surfaces, qty. in pack 10 piece(s), in self-service display pack	19,65 23,58	<b>499893</b>
<b>3 Magazine for holding edging KSP-KA 65</b>	for KA 65, for the safe guidance of delicate and thin edging into the edge bander KA 65, safe guidance of long edges without damaging or soiling, max. edge lengths of 8 m (edge thickness of 2mm) possible, max. edge height 45 mm, max. edge thickness 2 mm, in a carton	40,10 48,12	<b>499479</b>
<b>4 Sanding block HSK 80x133 H</b>	for attaching StickFix 80 x 133 mm abrasive sheets, hard, in self-service display pack	17,95 21,54	<b>495967</b>
<b>5 Polishing agent MPA 6000/1</b>	Sanding polish, does not contain silicone, volume 500 ml, In plastic bottle	12,95 15,54 25,90 / 1 l 31,08 / 1 l	<b>492424</b>
<b>6 Perforated top LP-KA65 MFT/3</b>	for KA 65, allows the user to swivel the machine [0-47°] in the bench in combination with adapter plate AP-KA 65 and position the workpiece horizontally during edging – for convenient and safe guidance, even with larger objects, dimensions length x width 1102 x 718 mm, in a carton	108,95 130,74	<b>500366</b>
<b>7 Natural adhesive EVA nat 48X-KA 65</b>	for KA 65, natural colour tone suitable for all types of decor, EVA universal adhesive with high melting point, also suitable for use on objects with a higher resistance to temperatures, 48x natural EVA adhesive, adhesive diameter 63 mm, adhesive height 26 mm, processing temperature 190 °C, in a carton	83,65 100,38	<b>499812</b>
<b>Adhesive, white EVA wht 48X-KA 65</b>	for KA 65, perfect join quality on white decor, EVA universal adhesive with high melting point, also suitable for use on objects with a higher resistance to temperatures, 48x white EVA adhesive, adhesive diameter 63 mm, adhesive height 26 mm, processing temperature 200 °C, in a carton	83,65 100,38	<b>499813</b>
<b>8 Scraper ZK HW 45/45</b>	smoothing away impact marks left by cutters during the routing process (R1, R1.5 and R2 mm curves), trimming overhanging material after the edge is cut (plastic edging) without damaging the surface of the workpiece, Dimensions [L x W x H] 45 x 45 x 1,2 mm, curves 1/1,5/2 mm, in self-service display pack	41,85 50,22	<b>499749</b>
<b>9 Edge trimming set KB-KA 65 SYS</b>	for KA 65, protective edging, additional roll, trimming device, scraper, base runner scratch protector with 3x felt layers, 5x polishing felts, 20x StickFix abrasive sheets BR2 80x133 P320, HSK-A 80x130, 5x StickFix sanding cloth S 800, polish MPA 6000, in a SYSTAINER SYS 4 T-LOC	321,50 385,80	<b>500177</b>
<b>10 Polishing felt PF-STF 80x133 STF H/5</b>	for hand sanding block HSK 80 x 133, dimensions length x width 80 x 133 mm, qty. in pack 5 piece(s), in self-service display pack	11,85 14,22	<b>499894</b>

## Additional roll

**Mobile attachment of edging to moulded parts with curves**

With the CONTURO, radii with an inner radius of 50 mm and a minimum outer radius of 25-30 mm can be cut. The following applies: The thicker and more fragile the edging material, the greater the radius must be. The additional roll supports you by using the two rolls to press against the radius.



## Magazine for holding edging

**Attaching long strips of edging**

With edge bands longer than 150 cm, there is a risk that the edging will drag on the floor and become soiled or stuck. The edging holder (accessory) was designed to avoid this situation. The edging is rolled up neatly in the holder to guarantee an even feed into the machine. As a result, you can process up to 8 m of edging both quickly and easily.



## Scraper

**Edge finish**

The final sanding process comes after the gluing and edge trimming: Cut off edge protrusion, smooth down the edge, perform finishing work on corners and polish the edge if necessary to high gloss. Ideal for routing edges: The edge router MFK 700 Basic with new ball bearing brake and chip deflection especially for clean processing, also for sensitive edges. There is the scraper made from longlife solid carbide especially for smoothing the edge. In order to smooth routed radii or round off edges, it is equipped with three integrated radii (R1, R1.5 and R2 mm).







## Dust extraction

<b>Overview of products and applications</b>	264
<b>Compact mobile dust extractor</b> CT 17, CTL MINI, CTL MIDI	268
<b>CLEANTEC mobile dust extractors</b> CT 26/36/48	271
<b>CLEANTEC AUTOCLEAN</b> CT 26/36/48 AC, <b>mobile dust extractors</b> CT 36 AC PLANEX, CT 36 AC HC	273
<b>CLEANTEC special extractors</b> CT 48 EC, CT 48 EC/B22, CTH 26/48	276
<b>Accessories and consumable materials</b>	280
The Festool system	



# Dust extraction

## Overview of products and applications

Compact yet effective. Lightweight yet powerful. Whether on the construction site or in the workshop – Festool mobile dust extractors are prepared for every challenge.

Page 268 — 269 — 270 — 271 — 271 — 272

CT 17

CTL MINI

CTL MIDI

CTL 26/36

CTM 26/36

CTL/CTM 48



### Applications

Compact mobile dust extractor CLEANTEC

CLEANTEC mobile dust extractors

#### Application area

Assembly (low quantities of coarse dust)

Workshop, industry

Building site, drywall construction (large quantities of fine dust)

Zone 22

#### Application

Extraction of dust from power tools

Dust extraction from air tools (LE variants)

Cleaning work

Continuous industrial use

#### Special features

Modular flexibility with 2 sockets/compressed air module

AUTOCLEAN fully automatic main filter cleaning system

Combination with ASA/EAA

#### Type of dust

wood dust

Mineral, quartziferous dust

Aluminium, powder coating and polyurethane dust

Carcinogenic dust and asbestos

#### Technical data

	CT 17	CTL MINI	CTL MIDI	CTL 26/36	CTM 26/36	CTL/CTM 48
Power consumption (W)	400-1200	400-1200	400-1200	350-1200	350-1200	350-1200
Max. flow rate (l/min)	3700	3700	3700	3900	3900	3900
Max. vacuum (Pa)	24000	24000	24000	24000	24000	24000
Max. container/filter bag capacity (l)	17/17	10/7,5	15/12,5	26/24 / 36/34	26/24 / 36/34	48/46
Dimensions (L x W x H) (mm)	445 x 380 x 485	430 x 330 x 420	430 x 330 x 470	630 x 365 x 540 / 630 x 365 x 596	630 x 365 x 540 / 630 x 365 x 596	740 x 406 x 1005
Weight (kg)	9,4	8,7	9	13,9 / 14,4	13,9 / 14,4	18,8

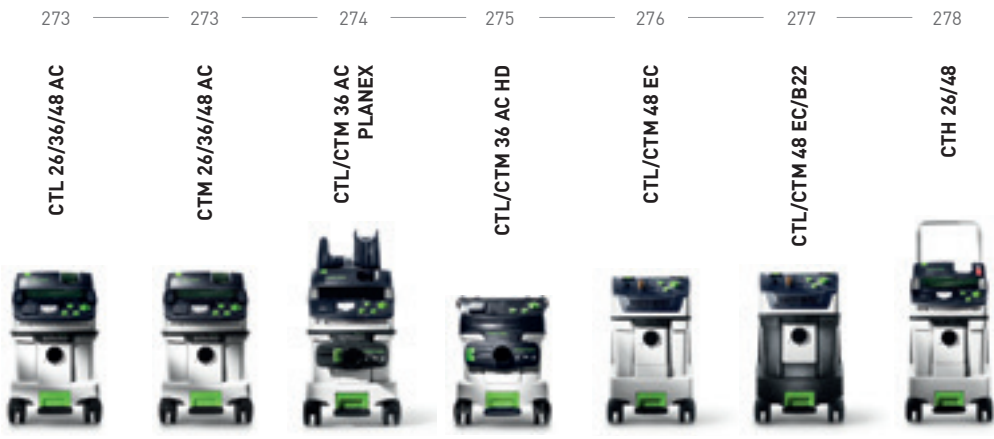

CLEANTEC AUTOCLEAN mobile dust extractors

CLEANTEC special extractors

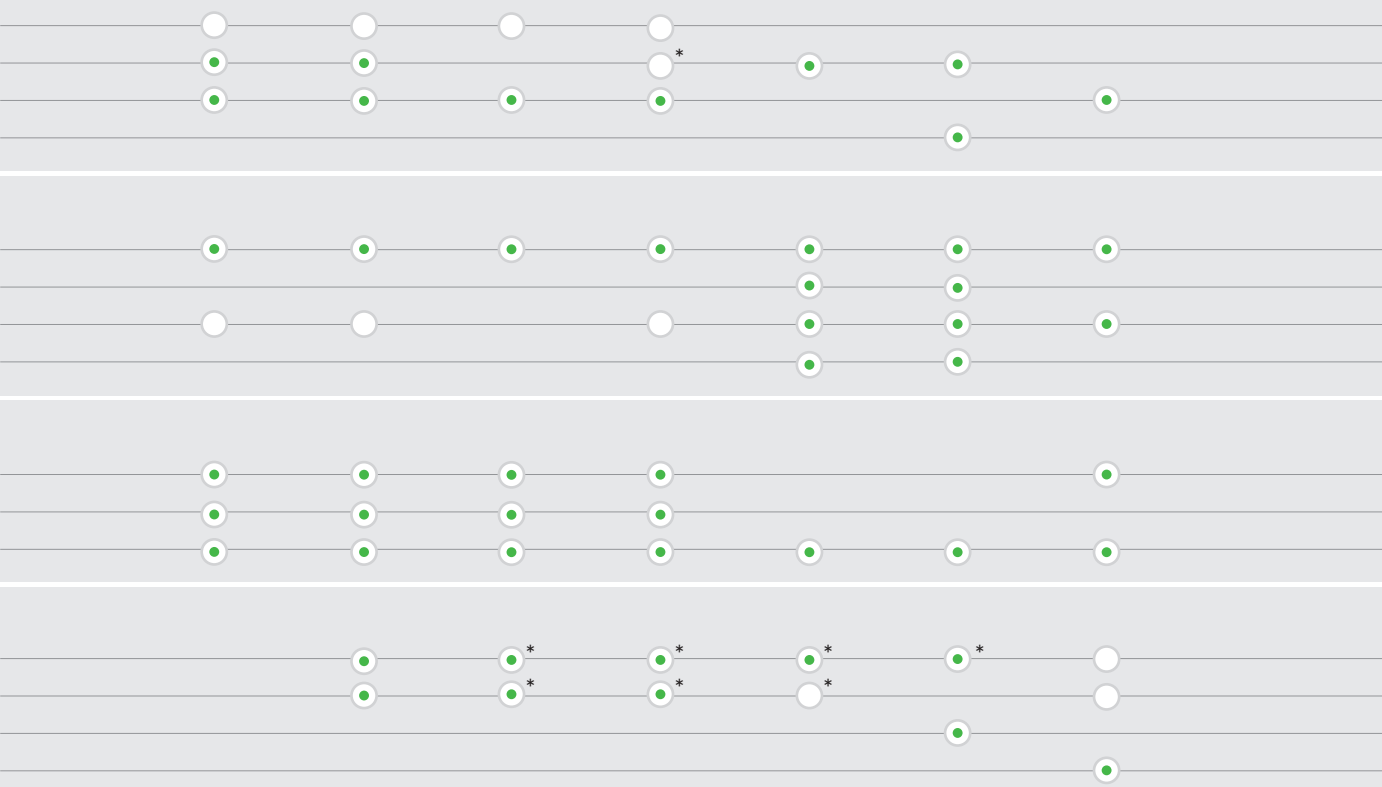

\* CTM only    ● Extremely appropriate    ○ Appropriate

350-1200	350-1200	350-1200	350-1200	150-1100	150-1100	350-1000
3900	3900	3900	3900	3400	3400	3900
24000	24000	24000	24000	23000	23000	24000
26/24 / 36/34 / 48/46	26/24 / 36/34 / 48/46	36/34	36/34	48/46	48/46	26/24 / 48/46
630 x 365 x 540 / 630 x 365 x 596 / 740 x 406 x 1005	630 x 365 x 540 / 630 x 365 x 596 / 740 x 406 x 1005	630 x 365 x 596	673 x 365 x 522	630 x 406 x 640	630 x 406 x 640	630 x 365 x 540 / 740 x 406 x 1005
14,7 / 15,2 / 19,6	14,7 / 15,2 / 19,6	15,2	15	17,9	18,6	13,9 / 18,8

## Dust extraction

**We recommend using a dust extraction system.**

**We strongly recommend choosing the right extractor when selecting a dust extraction system.**

When working in a dusty environment or handling materials that generate large quantities of dust, your main priority should be protecting your health. How harmful the dust is to your health depends on the size of the particles as well as the quantity and time that the materials remain inside your lungs.

The smaller the dust particles are, the deeper they can penetrate into the lung tissue and this is why finer particles are much more harmful to the airways, with many being categorised as extremely hazardous to health.

In the interests of your own health, it is imperative that you keep the air clean when handling mineral dust that invariably contains quartziferous substances and always work with a certified and approved dust extractor or safety extractor.

Your Industrial Employers' Liability Insurance Association will provide you with detailed information and specially prepared lists of substances that exceed specified OEL (occupational exposure limits).



CTL MINI/MIDI  
CTL 26/36/48/48  
EC

Specialists for dust with OEL  
> 1 mg/m<sup>3</sup>.



CTM 26/36/48/48  
EC

Specialists for dust with OEL  
> 0.1 mg/m<sup>3</sup>.  
For quartziferous, mineral dust and  
wood dust.



CTH 26/48

Specialists for dust with OEL  
≤ 0.1 mg/m<sup>3</sup>.  
For carcinogenic and pathogenic  
dust, e.g. asbestos and mould.



CTL 48 LE EC/B 22  
CTM 48 LE EC/B 22

Specialised in the extraction of  
flammable and explosive dust.

### Dust categories in accordance with EN 60335-2-69, Appendix AA

	Appropriate	Max. permeability (test)	Disposal	Contamination risk
<b>L (Low)</b>	- dust with OEL > 1 mg/m <sup>3</sup>	1% (filter material)		
<b>M (Medium)</b>	- dust with OEL ≤ 0.1 mg/m <sup>3</sup> - mineral dust - wood dust (also beech/oak)	0.1% (complete machine incl. upholstery nail test)	Dust-free	Cap for transportation
<b>H (High)</b>	- dust with OEL > 0.1 mg/m <sup>3</sup> - carcinogenic dust - dust containing pathogens	0.005% (complete machine incl. upholstery nail test)	dust-free	Cap for transportation

## As important as the air you breathe. 3 good reasons why you should work with a dust extractor.

1. Let us begin with the most important thing first: your health. Mobile dust extractors can collect up to 99.995% of dust generated during classic sanding, sawing and routing applications. In other words, any particles that would have otherwise been inhaled, find their way directly into a large collection container.
2. A pleasant side-effect: Mobile dust extractors also make your customers happy. They keep your work environment as clean as your working results. Not only do you leave a lasting impression but also significantly increase the likelihood of your customers recommending you.
3. And finally, they extend the life of your electric power tools. Particles are safely extracted into the container, meaning no contact with the motor.

### Full utilisation of the container volume

The sophisticated container geometry, compatible SELFCLEAN filter bag and space-saving flat filter combine to produce a net volume that corresponds almost exactly to the gross volume of the container.

### SYS-Dock

Simple transportation, better organisation and endless flexibility. The SYS-Dock for the safe connection of SYSTAINER, SORTAINER and SYS-ToolBox units.

### Hose holder

The integral hose holder eliminates the need for external hooks and protects the suction hose and mains cable from damage. The suction hose winds around the holder for clean, compact transportation.

### AUTOCLEAN technology

Less cleaning work and constant suction power. The AUTOCLEAN automatic cleaning system eliminates the need to clean the main filter manually. Individual cleaning intervals can be defined to guarantee powerful, constant suction.

### Systems get it done

Festool mobile dust extractors are an integral part of the system concept and perfectly adapted to Festool electric power and air tools. They switch on automatically when the tool is activated. Any mobile dust extractor can be fitted with an optional handle or tool holder or combined with a Workcenter or Tool-center to create a mobile work station.

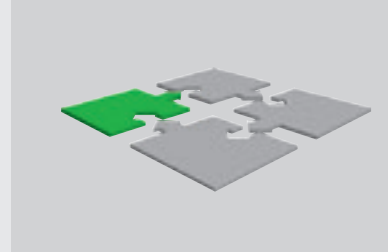

## Dust extraction

Mobile dust extractor CLEANTEC CT 17



# CLEANTEC CT 17



### Matter of cleanliness.

Ideal for cleaning offices, garages, vehicles and construction sites. Also suitable for extracting water.

### Specialists for cleaning work.

- ▶ Maximum utilisation of filter bag capacity due to new, innovative design principle.
- ▶ High suction performance and volume flow due to single-level powerful turbine.
- ▶ Blow function with end cap on the rear of the housing
- ▶ Electronic level control for liquid suction

#### Technical data

Power consumption (W)	400-1200
Airflow max. (l/min)	3700
Max. vacuum (Pa)	24000
Filter surface area (cm <sup>2</sup> )	4600
Rubber-insulated mains cable (m)	5,5
Container/Filter bag capacity (l)	17/17
Dimensions (L x W x H) (mm)	445 x 380 x 485
Max. appliance socket connected load (W)	2400
weight (kg)	9,4



= with electronics

Items Included	RRP in £*	Order no.
suction hose Ø 27 mm x 3,5 with rotatable dust extraction coupling, double-wall filtering bag, in a carton		
<b>CT 17 E GB</b>	208,00 249,60	<b>768472</b>

\* Recommended retail price of manufacturer. Dealer prices may vary.  
Excl. VAT.  
Incl. VAT.

#### System accessories from page 282





# CLEANTEC CTL MINI

#### The small assembly extractor with 10 l container volume.

- ▶ Extremely compact and lightweight, for simple transport
- ▶ Better organisation thanks to hose depot for safe storage of hose and cable
- ▶ Strong suction power thanks to compact high-performance turbine and conical suction hose
- ▶ SYSTAINERS are secured to Sys-Dock in an instant

#### Technical data

Power consumption (W)	400-1200
Airflow max. (l/min)	3700
Max. vacuum (Pa)	24000
Filter surface area (cm <sup>2</sup> )	5000
Rubber-insulated mains cable (m)	7,5
Container/Filter bag capacity (l)	10/7,5
Dimensions (L x W x H) (mm)	430 x 330 x 420
Max. appliance socket connected load (W)	2400
weight (kg)	8,7



= with electronics

Items Included	RRP in £*	Order no.
fitted filter bag, suction hose, Ø 27/32 x 3.5 m AS with rotating angle adapter at extractor side, hose holder, Sys-Dock with T-LOC function, in a carton		
<b>CTL MINI GB 240V</b>	306,00 367,20	<b>584153</b>
<b>CTL MINI GB 110V</b>	306,00 367,20	<b>584154</b>



09

#### Ideal for carrying en route.

With a low weight and compact dimensions, the CTL MINI is easy to transport and therefore the first choice for assembly tasks. The compact wet/dry extractor is ideal for extracting small to medium volumes of dust and dirt. For class L dust.

\* Recommended retail price of manufacturer. Dealer prices may vary.  
Excl. VAT.  
Incl. VAT.

#### System accessories from page 282



## Dust extraction

Mobile dust extractor CLEANTEC CTL MIDI



# CLEANTEC CTL MIDI



### Small on the outside, large on the inside.

The CTL MIDI is the ideal companion for assembly, installation and renovation work. The compact wet/dry extractor with 15 l container volume is perfect for extracting small to medium volumes of dust and dirt. For class L dust.

### The compact assembly extractor with 15 l container volume.

- ▶ Extremely compact and lightweight, for simple transport
- ▶ Better organisation thanks to hose depot for safe storage of hose and cable
- ▶ Strong suction power thanks to compact high-performance turbine and conical suction hose
- ▶ SYSTAINERS are secured to Sys-Dock in an instant

#### Technical data

Power consumption (W)	400-1200
Airflow max. (l/min)	3700
Max. vacuum (Pa)	24000
Filter surface area (cm <sup>2</sup> )	5000
Rubber-insulated mains cable (m)	7,5
Container/Filter bag capacity (l)	15/12,5
Dimensions (L x W x H) (mm)	430 x 330 x 470
Max. appliance socket connected load (W)	2400
weight (kg)	9



= with electronics

#### Items Included

fitted filter bag, suction hose, Ø 27/32 x 3.5 m AS with rotating angle adapter at extractor side, hose holder, Sys-Dock with T-LOC function, in a carton

	RRP in £*	Order no.
<b>CTL MIDI GB 240V</b>	333,00 399,60	<b>584162</b>
<b>CTL MIDI GB 110V</b>	333,00 399,60	<b>584163</b>

\* Recommended retail price of manufacturer. Dealer prices may vary.  
Excl. VAT.  
Incl. VAT.

#### System accessories from page 282







product design award

2009

# CLEANTEC CT 26 / CT 36

## The true size can be found inside.

- ▶ Maximum utilisation of the container volume – the gross volume is the same as the net volume
- ▶ For every requirement: option of individually upgrading with an additional socket or compressed air module
- ▶ Constantly high suction because of the compact high performance turbine
- ▶ Antistatic function gives electrostatic charging no chance

Technical data	CT 26	CT 36
Power consumption [W]	350-1200	350-1200
Airflow max. [l/min]	3900	3900
Max. vacuum [Pa]	24000	24000
Filter surface area [cm <sup>2</sup> ]	6318	6318
Rubber-insulated mains cable (m)	7,5	7,5
Container/Filter bag capacity [l]	26/24	36/34
Dimensions [L x W x H] (mm)	630 x 365 x 540	630 x 365 x 596
Max. appliance socket connected load [W]	2400	2400
weight [kg]	13,9	14,4



■ = with electronics

Items Included	RRP in £*	Order no.
SELF-CLEAN filter bag, suction hose Ø 27 mm x 3,5 m-AS, hose holder, Sys dock, cable holder, in a carton		
<b>CTL 26 E GB 240V</b>	445,00 534,00	<b>583499</b>
<b>CTL 26 E GB 110V</b>	445,00 534,00	<b>583498</b>
<b>CTL 36 E GB 240V</b>	536,00 643,20	<b>583844</b>

\* Recommended retail price of manufacturer. Dealer prices may vary.  
Excl. VAT.  
Incl. VAT.

System accessories  
from page 282



WCR 1000 Workcenter  
from page 358

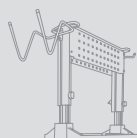

09

## All-rounder in the perfect size.

Compact yet effective. Lightweight yet powerful. Whether on the construction site or in the bodyshop – the perfected container geometry of the CLEANTEC CT 26/36 offers a significantly larger capacity with minimal external dimensions.

## Dust extraction

Mobile dust extractor CLEANTEC CT 48



# CLEANTEC CT 48



### There's more to it than meets the eye.

- ▶ Large capacity for large volumes of dust and coarse chips
- ▶ Constantly high suction because of the compact high performance turbine
- ▶ Antistatic function gives electrostatic charging no chance
- ▶ Can be individually equipped with additional socket or compressed air module for every application

#### Technical data

Power consumption (W)	350-1200
Airflow max. (l/min)	3900
Max. vacuum (Pa)	24000
Filter surface area (cm <sup>2</sup> )	6318
Rubber-insulated mains cable (m)	7,5
Container/Filter bag capacity (l)	48/46
Dimensions (L x W x H) (mm)	740 x 406 x 1005
Max. appliance socket connected load (W)	2400
weight (kg)	18,8



= with electronics

### For use in the workshop.

The CT 48 has a container volume of 48 litres, which is ideal for extracting large quantities of dust in the bodyshop. As CTL and CTM it is suitable for dust classes L and M.

Items Included	RRP in £*	Order no.
SELF CLEAN filter bag, suction hose Ø 27 mm x 3,5 m-AS, hose holder, Sys dock, cable holder, handle, in a carton		
<b>CTL 48 E</b>	605,00	<b>584070</b>
	726,00	
<b>CTL 48 E LE</b>	698,00	<b>584078</b>
compressed air module	837,60	
<b>CTM 48 E</b>	760,00	<b>584080</b>
end cap for intake adapter	912,00	
<b>CTM 48 E LE</b>	837,00	<b>584082</b>
compressed air module, end cap for intake adapter	1.004,40	

\* Recommended retail price of manufacturer. Dealer prices may vary.  
Excl. VAT.  
Incl. VAT.

#### System accessories from page 282



#### WCR 1000 Workcenter from page 358

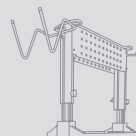

#### CT boom arm from page 290



## Dust extraction

Mobile dust extractors CLEANTEC  
CT 26 AC / CT 36 AC / CT 48 AC



# CLEANTEC

## CT 26 / 36 / 48 AC



### Fully automatic filter cleaning.

- ▶ AUTOCLEAN automatic main filter cleaning system with infinitely adjustable cleaning intervals
- ▶ ComfortClean closing slide (accessory) for even more powerful cleaning
- ▶ Constantly high suction because of the compact high performance turbine
- ▶ Antistatic function gives electrostatic charging no chance

Technical data	CT 26 AC	CT 48 AC
Power consumption [W]	350-1200	350-1200
Airflow max. [l/min]	3900	3900
Max. vacuum [Pa]	24000	24000
Filter surface area [cm <sup>2</sup> ]	6318	6318
Rubber-insulated mains cable (m)	7,5	7,5
Container/Filter bag capacity [l]	26/24	48/46
Dimensions [L x W x H] (mm)	630 x 365 x 540	740 x 406 x 1005
Max. appliance socket connected load [W]	2400	2400
weight [kg]	14,7	19,6



■ = with electronics

Items Included	RRP in £*	Order no.
High-performance main filter, SELFCLEAN filter bag, disposal bag, suction hose Ø 27 mm x 3,5 m-AS, hose holder, Sys dock, cable holder, in a carton		
<b>CTL 26 E AC GB 240V</b>	524,00 628,80	<b>584021</b>
<b>CTL 48 E AC</b>	680,00	<b>584085</b>
handle	816,00	
<b>CTM 48 E AC</b>	819,00	<b>584095</b>
handle, end cap for intake adapter	982,80	

**CT 36: This product is not available in Great Britain.**

### No more clogged filters.

We have got something against clogged filters: the CLEANTEC AC. An automatic filter cleaning system keeps the filter clean and maintains a constant suction power. One-touch cleaning can be initiated at any time.

\* Recommended retail price of manufacturer. Dealer prices may vary.  
Excl. VAT.  
Incl. VAT.

System accessories  
from page 282



WCR 1000 Workcenter  
from page 358

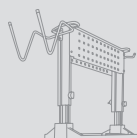

## Dust extraction

Mobile dust extractor CLEANTEC CT 36 AC PLANEX

# CLEANTEC CT 36 AC PLANEX



### Our contribution to a shorter work time.

The quicker a sander removes material, the more powerful the connected mobile dust extractor needs to be. The powerful CT 36 AC PLANEX was designed specifically for the extreme material removal rate of the PLANEX long-reach sander. Includes a tool holder, kink-proof hose and series standard ComfortClean closing slide for even more efficient filter cleaning. Perfect results every time at maximum speed.

### Ideal for drywall construction.

- ▶ The perfect mobile dust extractor for the PLANEX long-reach sander
- ▶ AUTOCLEAN automatic main filter cleaning system with infinitely adjustable cleaning intervals
- ▶ Constantly high suction because of the compact high performance turbine
- ▶ Antistatic function gives electrostatic charging no chance

#### Technical data

Power consumption (W)	350-1200
Airflow max. (l/min)	3900
Max. vacuum (Pa)	24000
Filter surface area (cm <sup>2</sup> )	6318
Rubber-insulated mains cable (m)	7,5
Container/Filter bag capacity (l)	36/34
Dimensions (L x W x H) (mm)	630 x 365 x 596
Max. appliance socket connected load (W)	2400
weight (kg)	15,2



= with electronics

Items Included	RRP in £*	Order no.
PLANEX tool holder, in a carton		
<b>CTM 36 E AC-PLANEX GB 110V</b>	794,00 952,80	<b>584061</b>

\* Recommended retail price of manufacturer. Dealer prices may vary.  
Excl. VAT.  
Incl. VAT.

#### System accessories from page 282



#### PLANEX LHS 225 from page 321





# CLEANTEC CT 36 AC HD

#### The construction site extractor with automatic cleaning.

- ▶ Constantly high suction power thanks to automatic cleaning AUTOCLEAN
- ▶ Full container volume of 36 can be used thanks to clever integration of filter technology in the head of the extractor
- ▶ Extremely robust design with large wheels and steel axis for use on the construction site
- ▶ Optimal for power tools with socket outlet and automatic switch-on with start-up and shut-down delay, as well as infinitely variable extraction power control

Technical data	CTL 36 E AC HD	CTM 36 E AC HD
Power consumption (W)	350-1200	350-1200
Airflow max. (l/min)	3900	3900
Max. vacuum (Pa)	24000	24000
Filter surface area (cm <sup>2</sup> )	6318	6318
Rubber-insulated mains cable (m)	7,5	7,5
Container/Filter bag capacity (l)	36/34	36/34
Dimensions (L x W x H) (mm)	673 x 365 x 522	673 x 365 x 522
Max. appliance socket connected load (W)	2400	2400
weight (kg)	15,2	15,2



■ = with electronics

This product is not available in Great Britain.



#### Heavy-duty tool.

The CT 36 AC HD is in its element when there is an abundance of dust, which occurs, for example, when working with masonry renovators and diamond grinders. The automatic main filter cleaning flushes the main filter regularly, thus ensuring a constantly high suction power.

09

System accessories  
from page 282



Renovation millers  
from page 317

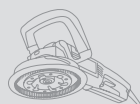

## Dust extraction

### Mobile dust extractor CLEANTEC CT 48 EC



1913

Brushless EC-TEC motor for a long service life and a high level of efficiency



# CLEANTEC CT 48 EC



### Designed for continuous industrial use.

- ▶ Constant power from the EC-TEC drive with a service life several times longer than a universal motor
- ▶ With suction power adjustment, flexible adaptation to any working situation
- ▶ Antistatic function gives electrostatic charging no chance
- ▶ Standard equipment for connecting to an energy box, with compressed air connection

#### Technical data

Power consumption (W)	150-1100
Airflow max. (l/min)	3400
Max. vacuum (Pa)	23000
Filter surface area (cm <sup>2</sup> )	6318
Rubber-insulated mains cable (m)	7,5
Container/Filter bag capacity (l)	48/46
Dimensions (L x W x H) (mm)	630 x 406 x 640
Max. appliance socket connected load (W)	2400
weight (kg)	17,9



= with electronics

### Reliable. Durable. Powerful.

Tough continuous operation is its speciality and the EC-TEC drive concept guarantees greater reliability and a longer life. For relentless suction power when processing plastic, ceramic, wooden or painted surfaces.

Items Included	RRP in £*	Order no.
SELF-CLEAN filter bag, suction hose Ø 27 mm x 3,5 m-AS, cable holder, compressed air module, in a carton		
<b>CTL 48 E LE EC</b>	1.162,00 1.394,40	<b>584134</b>
<b>CTM 48 E LE EC</b>	1.302,00 1.562,40	<b>584132</b>

\* Recommended retail price of manufacturer. Dealer prices may vary.  
Excl. VAT.  
Incl. VAT.

#### System accessories from page 105, 282



#### WCR 1000 Workcenter from page 358

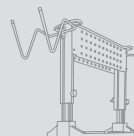

## Dust extraction

### Mobile dust extractor CLEANTEC CT 48 EC/B22



Brushless EC-TEC motor for a long service life and a high level of efficiency



2013

# CLEANTEC CT 48 EC/B22



#### For maximum safety.

- ▶ Conforms with ATEX Directive 94/9/EC for Zone 22 – dust from explosion classes St1, St2 and St3 is reliably extracted
- ▶ Constant power from the EC-TEC drive with a service life several times longer than a universal motor
- ▶ Antistatic function gives electrostatic charging no chance
- ▶ Standard equipment for connecting to an energy box, with compressed air connection

#### Technical data

Power consumption (W)	150-1100
Airflow max. (l/min)	3400
Max. vacuum (Pa)	23000
Filter surface area (cm <sup>2</sup> )	6318
Rubber-insulated mains cable (m)	7,5
Container/Filter bag capacity (l)	48/46
Dimensions (L x W x H) (mm)	630 x 406 x 640
Max. appliance socket connected load (W)	2400
weight (kg)	18,6



☐ = with electronics

Items Included	RRP in £*	Order no.
SELFCLEAN filter bag, suction hose Ø 27 mm x 3,5 m-AS, cable holder, no compressed air module, in a carton		
<b>CTL 48 E LE EC/B22</b>	1.626,00 1.951,20	<b>584131</b>
<b>CTM 48 E LE EC/B22</b>	1.767,00 2.120,40	<b>584130</b>

#### For flammable and explosive dusts.

The CT 48 EC/B22 special extractor with EC-TEC drive is designed for continuous use. The robust ABS plastic container is fitted with additional flame protection and is therefore suitable for the safe extraction of everything from aluminium, paper, soot and powder coating dust to glass-fibre and carbon-fibre reinforced plastics.

\* Recommended retail price of manufacturer. Dealer prices may vary.  
Excl. VAT.  
Incl. VAT.

#### System accessories from page 105, 282



#### WCR 1000 Workcenter from page 358

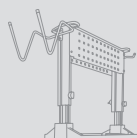

## Dust extraction

Mobile dust extractor CLEANTEC CTH 26 / CTH 48



2012

# CLEANTEC CTH 26 / CTH 48



### The specialist for the toughest demands.

Asbestos, mould, mineral fibre dust, lead, cadmium, nickel, zinc chromate. Many risks – one defence: the CTH special application extractor from Festool. Carcinogenic and pathogenic dust stand no chance. With a 99.995% degree of filtration even mould removal and asbestos abatement or wood-working with dangerous impregnating compounds pose no health problems.

### No chance for hazardous dust.

- ▶ Protects health: approved for dust category H and asbestos dust
- ▶ Sealed tight – with dual-layer safety filter bag
- ▶ Constantly high suction because of the compact high performance turbine
- ▶ With infinitely variable suction power adjustment and antistatic function

Technical data	CTH 26	CTH 48
Power consumption (W)	350-1000	350-1000
Airflow max. (l/min)	3900	3900
Max. vacuum (Pa)	24000	24000
Filter surface area (cm <sup>2</sup> )	6318	6318
Rubber-insulated mains cable (m)	7,5	7,5
Container/Filter bag capacity (l)	26/24	48/46
Dimensions (L x W x H) (mm)	630 x 365 x 540	
Max. appliance socket connected load (W)	2400	2400
Dimensions (L x W x H) (mm)	740 x 406 x 1005	
weight (kg)	13,9	18,8



= with electronics

Items Included	RRP in £*	Order no.
safety filter bag, suction hose Ø 27 mm x 3,5 m-AS, hose holder, Sys dock, cable holder, in a carton		
<b>CTH 26 E / a</b>	677,00 812,40	<b>584139</b>
<b>CTH 48 E / a</b>	857,00 1.028,40	<b>584137</b>
handle		

\* Recommended retail price of manufacturer. Dealer prices may vary.  
Excl. VAT.  
Incl. VAT.

### System accessories from page 282







**Festool filter bags. Pure quality every time.**

Compatible filter bags are available for all Festool mobile dust extractors:

**SELCLEAN filter bag**

For single use and all types of dust. Self-cleaning effect prevents the formation of filter blocks, and the bag is closed prior to disposal for maximum health protection.

**Longlife filter bag**

High-strength, three-layer polyester cloth, suitable for multiple uses. Ideal for large volumes of dust and non-hazardous dust. Easy to empty by opening the sealing strip.

**Disposable bag**

Perfect for mobile dust extractors with AUTOCLEAN, e.g. when used with the PLANEX long-reach sander or for the extraction of coarse dirt and chips. Seal on the disposal bag guarantees dust-free disposal.

**Double-layered safety filter bag**

Mandatory for class H dust. Particularly safe with additional disposal bag that encloses the cloth filter bag.

Mobile dust extractors/ Special extractors	Design approval	Filter bags				
		SELCLEAN	PAPER	Longlife	Disposable bag	Double-layered safety filter bag
	Dust class					
CT 17			●			
CTL MINI/CTL MIDI	L	●		●		
CT 26	L	●		●		
	M	●				
CT 26 AC	H					●
	L	○		○	●	
CT 36	M	○		○	●	
	L	○		○	●	
CT 36 AC / AC HD	M	○		○	●	
	L	○		○	●	
CT 48	L	●		●		
	M	●				
	H					●
CT 48 AC	L	○		○	●	
	M	○		○	●	
CT 48 LE EC	L	●		●		
	M	●				
CT 48 LE EC/B22	L	●				
	M	●				

● suitable and recommended      ○ Possible, but with limitations

### The Festool system.

Because things work better when everything fits together: Which is why all Festool mobile dust extractors are equipped with an integrated hose garage and SYS-Dock for holding the SYSTAINER. Many models are also fitted with modular plug-in slots. A handle or removable tool holder can be added as an option. Furthermore, they are not only compatible with all Festool power and compressed air tools, but the various accessories are also interchangeable.



## Dust extraction

Accessories and consumable materials

Cleaning sets	282
Suction hoses and hose sleeves	283
Tubes and nozzles	288
Modules and boom arms	290
Filters and filter bags	291
CT and compressed air accessories	296



## Dust extraction











### System accessories

#### CLEANTEC cleaning sets

		Type	RRP in £*	Order no.
	<b>Cleaning set</b> crevice nozzle D 36 FD-210, upholstery nozzle D 36 PD, suction brush D 36 SP	D 27 / D 36 D-RS	11,20 13,44	<b>492392</b>
	<b>Standard cleaning set</b> hand pipe, bent D 36 HR-K, 3 extension tubes D 36 VR-K, floor nozzle, 4-piece D 36 BD270, crevice nozzle D 36 FD-210, upholstery nozzle D 36 PD, in a carton	D 27 / D 36 S-RS	32,55 39,06	<b>492389</b>
	<b>Professional cleaning set</b> hand pipe, bent D 36 HR-M, extension tube, special steel 3-piece D 36 VR-M3x, floor nozzle, switchable D 36 TD, crevice nozzle D 36 FD-210, in a carton	D 27 / D 36 P-RS	65,80 78,96	<b>492390</b>
	<b>Compact cleaning set</b> curved hand tube D 36 HR-K, 3 extension tubes D 36 VR-K, floor nozzle 4-piece D 36 BD270, crevice nozzle D 36 FD, upholstery nozzle D 36 PD, in a SYSTAINER SYS 1 T-LOC	D 27/D 36 K-RS-Plus	58,70 70,44	<b>497697</b>
	<b>Cleaning set for tradesmen</b> antistatic suction hose D 36x3,5m-AS, curved handle 36 HR-M, 3 extension tubes D 36 VR-M, carpet nozzle D 36 TD, crevice nozzle D 36 FD, upholstery nozzle D 36 PD, suction brush D 36 SP, in a SYSTAINER SYS 5 T-LOC	D 36 HW-RS-Plus	177,30 212,76	<b>497700</b>
	<b>Cleaning set for the workshop</b> antistatic suction hose D 36 x 3,5m-AS, curved handle D 36 HR-M, 3 extension tubes D 36 VR-M, floor nozzle D 36 BD370, in a SYSTAINER SYS 5 T-LOC	D 36 WB-RS-Plus	189,70 227,64	<b>497701</b>
	<b>Universal cleaning set</b> suction hose D 36x3,5m, curved hand tube D 36 HR-K, 3 extension tubes D 36 VR-K, floor nozzle D 36 BD300, crevice nozzle D 36 PD, suction brush D36S, in a SYSTAINER SYS 5 T-LOC	D 36 UNI-RS-Plus	116,55 139,86	<b>497702</b>
	<b>Cleaning set for industrial use</b> suction hose Ø 50 x 2,5m, 2 extension tubes D50VR-K, floor nozzle D 50 BD370, square nozzle D 50 QD, suction brush D 50 SP, crevice nozzle D 50 FD, in a carton	D 50 GS-RS	88,60 106,32	<b>454770</b>
	<b>Masonry renovation cleaning set</b> curved hand tube, D 36 HR-M, 3 extension tubes, D 36 VR-M, carpet nozzle, D 36 TD, groove nozzle D 36 FD, upholstery nozzle D 36 PD, in a SYSTAINER SYS 2 T-LOC	D 36 RS-M-Plus	107,95 129,54	<b>497698</b>
	<b>Floor cleaning set</b> curved hand tube, D 36 HR-M, 3 extension tubes, D 36 VR-M, floor nozzle, D 36 BD 370, in a SYSTAINER SYS 2 T-LOC	D 36 BD 370 RS-Plus	162,70 195,24	<b>497699</b>

### for CT mobile dust extractors and SR dust extractors



#### CLEANTEC suction hose anti-static version

		Type	RRP in £*	Order no.
	<b>Suction hose D 22 antistatic</b> temperature-resistant to +70°C, with rotating adapter and reducing sleeve, high flexibility: optimal for the PS/LS/ETS/RTS/DTS/RS300/DX, bleeder resistor (DIN IEC 312) < 1 MΩ/m, Diameter 22 mm, Length 3,5 m, in a carton	D 22x3,5m-AS	82,25 98,70 23,50 / 1 m 28,20 / 1 m	<b>456745</b>
	<b>Suction hose D 32/27, antistatic</b> for CTL MINI/MIDI, temperature-resistant to +70°C, from YOM 09/2013, with rotating angle adapter at extractor side, bleeder resistor (DIN IEC 312) < 1 MΩ/m, Diameter 27/32 mm, Length 3,5 m, in a carton	D 27/32x3,5m-AS	102,50 123,00 29,29 / 1 m 35,15 / 1 m	<b>499742</b>
	<b>Suction hose D 27 antistatic</b> temperature-resistant to +70°C, bleeder resistor (DIN IEC 312) < 1 MΩ/m, Diameter 27 mm, in a carton			
	with rotating adapter and connector, Length 3,5 m	D 27x3,5m-AS	89,85 107,82 25,67 / 1 m 30,80 / 1 m	<b>452878</b>
	with rotating adapter and connector, Length 5 m	D 27x5m-AS	115,10 138,12 23,02 / 1 m 27,62 / 1 m	<b>452880</b>
	ordered by metre (without rotating adapter or reducing sleeve)	D 27 MW-AS	26,00 31,20	<b>452384</b>
	special design only for SRM 312 LE-AS/SRM 70 LE-EC/CT 48 EC B 22, Length 3,5 m	D 27x3,5m-AS/B1	140,05 168,06 40,01 / 1 m 48,01 / 1 m	<b>489266</b>
	<b>Suction hose D 36 antistatic</b> temperature-resistant to +70°C, bleeder resistor (DIN IEC 312) < 1 MΩ/m, in a carton			
	with rotating adapter and connector, Diameter 36 mm, Length 3,5 m	D 36x3,5m-AS	114,10 136,92 32,60 / 1 m 39,12 / 1 m	<b>452882</b>
	for long-reach sander PLANEX, extremely flexible, kink-resistant suction hose, Diameter 36 mm, Length 3,5 m	D 36x3,5-AS/KS/LHS 225	123,15 147,78 35,19 / 1 m 42,23 / 1 m	<b>496972</b>
	with rotating adapter and connector, Diameter 36 mm, Length 5 m	D 36x5m-AS	151,35 181,62 30,27 / 1 m 36,32 / 1 m	<b>452884</b>
	with rotating adapter and connector, Diameter 36 mm, Length 7 m	D 36x7m-AS	196,65 235,98 28,09 / 1 m 33,71 / 1 m	<b>452886</b>
	ordered by metre (without rotating adapter or reducing sleeve), Diameter 36 mm	D 36 MW-AS	32,55 39,06	<b>452385</b>
	for CT AC and VCP, for masonry renovation and cleaning work, Conical, Diameter 36/32 mm, Length 3,5 m	D 36/32x3,5m-AS	101,85 122,22 29,10 / 1 m 34,92 / 1 m	<b>497925</b>

## Dust extraction



### System accessories

#### CLEANTEC suction hose plug it D 27 and D 32









		Type	RRP in £*	Order no.
	<b>Suction hose plug it D 27 antistatic</b> with plug it-connection, antistatic, Diameter 27 mm, Length 3,5 m, in a carton	plug it D 27x3,5m-AS	120,05 144,06	<b>493996</b>
	<b>Suction hose</b> with rotating adapter and connector, temperature-resistant to +70°C, bleeder resistor (DIN IEC 312) < 1 MΩ/m, in a carton			
	Diameter 27/22 mm, Length 3,5 m	D27/22x3,5 AS-GQ	135,05 162,06	<b>500269</b>
	Diameter 32/22 mm, Length 10 m	D32/22x10 AS-GQ	253,95 304,74	<b>500281</b>

#### for CT mobile dust extractors and SR dust extractors

#### CLEANTEC suction hose anti-static version

		Type	RRP in £*	Order no.
	<b>Suction hose D 50 antistatic</b> temperature-resistant to +70°C, bleeder resistor (DIN IEC 312) < 1 MΩ/m, Diameter 50 mm, in a carton			
	with 2x rotating adapter, Length 2,5 m	D 50x2,5m-AS	101,20 121,44 40,48 / 1 m 48,58 / 1 m	<b>452888</b>
	with 2x rotating adapter, Length 4 m	D 50x4m-AS	153,10 183,72 38,28 / 1 m 45,94 / 1 m	<b>452890</b>
	ordered by metre (without rotating adapter or reducing sleeve)	D 50 MW-AS	35,85 43,02	<b>452386</b>









### CLEANTEC suction hose

		Type	RRP in £*	Order no.
	<b>Suction hose D 27</b> temperature-resistant to +70°C, Diameter 27 mm, in a carton			
	with rotating adapter and connector, Length 3,5 m	D 27x3,5m	55,05 66,06 15,73 / 1 m 18,88 / 1 m	<b>452877</b>
	with rotating adapter and connector, Length 5 m	D 27x5m	62,10 74,52 12,42 / 1 m 14,90 / 1 m	<b>452879</b>
	ordered by metre (without rotating adapter or reducing sleeve)	D 27 MW	16,80 20,16	<b>452383</b>
	<b>Suction hose D 36/32</b> temperature-resistant to +70°C, Diameter 36 mm, in a carton			
	with rotating adapter and connector, Length 3,5 m	D 36x3,5m	70,80 84,96 20,23 / 1 m 24,28 / 1 m	<b>452881</b>
	with rotating adapter and connector, Length 5 m	D 36x5m	91,45 109,74 18,29 / 1 m 21,95 / 1 m	<b>452883</b>
	with rotating adapter and connector, Length 7 m	D 36x7m	105,00 126,00 15,00 / 1 m 18,00 / 1 m	<b>452885</b>
	ordered by metre (without rotating adapter or reducing sleeve)	D 36 MW	20,60 24,72	<b>454157</b>
	<b>Suction hose D 36/32</b> for all CT (except VCP 30 E) and VCP, temperature-resistant to +70°C, with rotatable dust extraction coupling, Diameter 36/32 mm, Length 3,0 m, in a carton	D 36/32x3,0 m	63,25 75,90 21,08 / 1 m 25,30 / 1 m	<b>768114</b>
	<b>Suction hose D 50</b> temperature-resistant to +70°C, Diameter 50 mm, in a carton			
	with 2x rotating adapter, Length 2,5 m	D 50x2,5m	63,85 76,62 25,54 / 1 m 30,65 / 1 m	<b>452887</b>
	with 2x rotating adapter, Length 4 m	D 50x4m	93,95 112,74 23,49 / 1 m 28,19 / 1 m	<b>452889</b>
	ordered by metre (without rotating adapter or reducing sleeve)	D 50 MW	22,55 27,06	<b>454158</b>
	<b>Adapter hose</b> for CS50, CS 70, CMS, 0,5 m hose D36 with two rotating adapters and connection coupling, anti-static D50/D50 VM-AS, for Y-shaped connection in conjunction with CTL MINI/MIDI, in a carton	AD-D36/CS50/CS70/CMS	26,35 31,62	<b>499196</b>

## Dust extraction

### System accessories







#### for CT mobile dust extractors and SR dust extractors

CLEANTEC hose sleeves		Type	RRP in £*	Order no.
	<b>Antistatic rotating adapter</b> hose connector to fit inlet nozzle of dust extractor, external Ø 58 mm			
	for antistatic suction hose D 27	D 27 DAG-AS	17,60 21,12	<b>452892</b>
	for antistatic suction hose D 36	D 36 DAG-AS	21,35 25,62	<b>452894</b>
	for antistatic suction hose D 50	D 50 DAG-AS	25,60 30,72	<b>452896</b>
	<b>Antistatic rotating angle adapter</b>			
	for antistatic suction hoses D 22 and D 27 on CTL MINI and CTL MIDI, up to YOM 08/2013	D 27 DAG/90°-AS	17,85 21,42	<b>456806</b>
	for antistatic suction hose D 32/27 on CTL MINI and CTL MIDI, from YOM 09/2013	D 32/27 DAG/90°-AS	19,75 23,70	<b>499907</b>
	<b>Rotating adapter</b> hose connector to fit inlet nozzle of dust extractor, external Ø 58 mm			
	for suction hose D 27	D 27 DAG	14,20 17,04	<b>452891</b>
	for suction hose D 36	D 36 DAG	17,20 20,64	<b>452893</b>
	for suction hose D 50	D 50 DAG	20,80 24,96	<b>452895</b>
		<b>Reducing sleeve, antistatic</b>		
for suction hose D 22, hose connector for electric tool or suction nozzle		D 22 DM-AS	12,60 15,12	<b>456756</b>
for suction hose D 27, hose connector for electric tool or suction nozzle		D 27 DM-AS	12,60 15,12	<b>487071</b>
	for suction hose D 36, hose connector for electric tool or suction nozzle	D 36 DM-AS	15,95 19,14	<b>487721</b>
		for suction hose D 36/32, for suction side connections (power tool or suction nozzle)	D 36/32 DM-AS	16,55 19,86



### for CT mobile dust extractors and SR dust extractors











#### CLEANTEC hose sleeves

		Type	RRP in £*	Order no.
	<b>Reducing sleeve</b> for suction hose D 36, for reducing to D 27 (machine)	RM D36/27-AS	12,35 14,82	<b>498528</b>
	<b>Reducing sleeve, antistatic</b> for long-reach sander PLANEX, for suction hose D 36, hose connector for electric tool or suction nozzle	D 36 DM-AS-LHS 225	17,00 20,40	<b>495013</b>
	<b>Extraction adapter</b> for connecting a D 50 suction hose to D 36 accessory	D 50/D 36 AS	11,50 13,80	<b>452897</b>
	<b>Bypass adapter</b> for hose sleeve D27, adapter with bypass function for increasing air throughput with DTS/DS/RTS/RS 400 and ETS/ES 125	AB DTS/RTS400/ ETS125-AS	15,10 18,12	<b>496112</b>
	<b>Y-piece, antistatic</b> for D 50/D 36/D 27, with blanking plug, for connection of two dust extraction hoses, for extractors that admit hazardous dust, simultaneous operation is not permitted	D 50 SV-AS/D 50 V	31,45 37,74	<b>452898</b>
	<b>Blanking plug</b> for closing the inlet nozzle, for retrofitting all CT/CTL mobile dust extractors	D 50/V	12,25 14,70	<b>452899</b>
	<b>Antistatic connector sleeve</b> to connect suction hoses D 50 / D 36 / D 27, the reducing sleeve on D 27/D 36 hoses must be replaced with a D 36/D 27 rotating adapter	D 50/D 50 VM-AS	14,10 16,92	<b>493047</b>

## Dust extraction



### System accessories

#### for CT mobile dust extractors and SR dust extractors

Tubes		Type	RRP in £*	Order no.
	<b>Hand tube</b> for D 27/D 36 stainless steel, curved	D 36 HR-M	38,15 45,78	<b>452900</b>
	polypropylene (PP), curved, with sliding air regulator for suction power adjustment	D 36 HR-K	17,00 20,40	<b>452901</b>
<b>Extension pipe</b>				
	for D 27/D 36, of stainless steel, 3-piece, Length 950 mm	D 36 VR-M 3x	44,55 53,46	<b>452902</b>
	for D 27/D 36, polypropylene (PP), 3-piece, Length 950 mm	D 36 VR-K 3x	19,05 22,86	<b>452903</b>
	for D 50, anodised aluminium, 1 piece, Length 1100 mm, in a carton	D 50 VR-M	86,00 103,20	<b>447599</b>
	for D 50, plastic, 2 pieces, Length 970 mm, in a carton	D 50 VR-K 2x	27,75 33,30	<b>440412</b>
<b>Floor nozzles</b>		Type	RRP in £*	Order no.
	<b>Floor nozzle</b> for D 27/D 36, high-quality industrial design, aluminium, with 2 castors and 2 brush inserts, width 370 mm, in a carton	D 36 BD 370	108,80 130,56	<b>452908</b>
	for D 50, high-quality industrial design, aluminium, with 2 castors and 2 brush inserts, width 450 mm, in a carton	D 50 BD 450	122,15 146,58	<b>452910</b>
	for D 27/D 36, plastic, with 2 castors and 2 brush inserts, width 300 mm	D 36 BD 300	28,05 33,66	<b>452907</b>
	for D 50, plastic, with 2 castors and 2 brush inserts, width 370 mm, in a carton	D 50 BD 370	46,70 56,04	<b>452909</b>
	for D 27/D 36, 4 pieces, plastic, with 3 replaceable inserts (brushes, rubber lips, carpet), width 270 mm	D 36 BD 270	25,20 30,24	<b>452906</b>









**Carpet and combination suction hose**

**for CT mobile dust extractors and SR dust extractors**

		Type	RRP in £*	Order no.
	<b>Carpet nozzle</b> for D 27/D 36, with sliding base, changeover from carpet to smooth floor, in a carton	D 36 TD	38,15 45,78	<b>452911</b>
	<b>Turbo combination suction brush</b> for D 27/D 36, for textile and linoleum floors, with 4 castors, brush rollers driven by intake air, width 270 mm, in a carton	D 36 TKB	98,35 118,02	<b>450644</b>

**for CT mobile dust extractors**

**Special nozzles/brushes**

		Type	RRP in £*	Order no.
	<b>Crevice nozzle</b>			
	for D 27/D 36, plastic, Length 300 mm	D 36 FD-300	6,00 7,20	<b>452904</b>
	for D 27/D 36, plastic, Length 210 mm	D 36 FD-210	4,90 5,88	<b>492391</b>
	for D 50, Length 200 mm	D 50 FD	16,10 19,32	<b>452912</b>
	<b>Suction brush</b>			
	for D 27/D 36, Diameter 70 mm	D 36 SP	8,30 9,96	<b>440404</b>
	for D 50, Diameter 85 mm	D 50 SP	22,75 27,30	<b>440419</b>
	<b>Upholstery nozzle</b> for D 27/D 36, plastic, with brush insert, width 120 mm	D 36 PD	6,55 7,86	<b>440406</b>
	<b>Universal brush nozzle</b> for D 27/D 36, plastic, with brush rim and rotary hinge	D 36 UBD	12,00 14,40	<b>498527</b>
	<b>Bevel-ended nozzle</b> for D 27/D 36, Rubber, Length 190 mm, Diameter 40 mm	D 36 SRD	16,65 19,98	<b>411810</b>
	<b>Flat nozzle</b> for D 27, special rubber, oil resistant, width 100 mm	D 27 FDG	43,10 51,72	<b>440408</b>

## Dust extraction

### System accessories

#### Nozzle and tube accessory storage



**Nozzle and tube accessory storage**  
for CT 26/36/48, for accommodation of curved hand pipe, 3-piece extension pipes, floor nozzle and up to four further nozzles, in a carton

Type	RRP in £*	Order no.
ZBA-D/R CT26/36/48	28,80 34,56	<b>496370</b>

#### for CT mobile dust extractors

#### Modules for attachment system CTL/CTM 26/36/48



**Energy box module**  
for CT 26/36/48, for connecting a CT mobile dust extractor with an energy box or boom arm, not required in LE version, in a carton

Type	RRP in £*	Order no.
EAA CT 26/36/48	49,65 59,58	<b>496143</b>



**Electrical outlet module**  
for CT 26/36/48, in a carton

electrical outlet with continuous power

Modul-SD CT 26/36/48	38,65 46,38	<b>496142</b>
----------------------	----------------	---------------

electrical outlet with automatic On and Off switch

Modul-SD E/A CT 26/36/48	38,65 46,38	<b>496405</b>
--------------------------	----------------	---------------



**Compressed air module**  
for CT 26/36/48, for upgrading E model mobile dust extractors, with additional compressed air automatic On and Off switching mechanism, in a carton

DL CT 26/36/48	168,10 201,72	<b>496141</b>
----------------	------------------	---------------

#### CT boom arm



**CT boom arm**  
pipe set with connections, Length 2119 mm, width 1136 mm, in a carton

for CT 44, CT 48, without handle

Type	RRP in £*	Order no.
CT-ASA	223,30 267,96	<b>492452</b>

for CT22, CT 33, with handle SB-CT

CT-ASA/SB	259,85 311,82	<b>492770</b>
-----------	------------------	---------------



for CT 26/36, boom arm for mounting to all CT 26/36 models (except CT 36 AC HD), with the SB-CT 26/36 handle

CT-ASA CT 26/36/SB	279,45 335,34	<b>496468</b>
--------------------	------------------	---------------







**Tool holder**  
for CT-ASA, CT-ASA/SB, for safe, ergonomic storage of two electric power or pneumatic tools, in a carton

WHR/CT-ASA	45,45 54,54	<b>493558</b>
------------	----------------	---------------

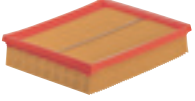
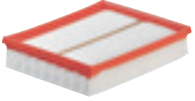
for CT mobile dust extractors

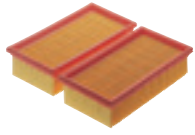
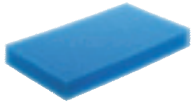
CLEANTEC filter and filter bags



		Type	RRP in £*	Order no.
	<b>Filter element</b>			
	for CT 17 E, VCP 170 E, VCP 320 E, for dry extraction, qty. in pack 1 piece(s), in a carton	HF-CT 17	23,95 28,74	<b>769134</b>
	for CTL MINI/MIDI, qty. in pack 1 piece(s)	HF-CT-MINI/MIDI	15,95 19,14	<b>456790</b>
	for CT 26/36/48, not suitable for mobile dust extractors with AUTOCLEAN function, qty. in pack 1 piece(s), in a carton	HF-CT 26/36/48	26,10 31,32	<b>496170</b>
	for CT 26/36/48, for CT AC and VCP, main filter optimised for self-cleaning, in a carton	High Performance HF CT 26/36/48	34,85 41,82	<b>496172</b>
	for CTH 26, CTH 48, special filter complies with the requirements of dust class H	HF CTH 26/48	54,90 65,88	<b>498995</b>
	for CT 26/36/48, not suitable for mobile dust extractors with AUTOCLEAN function, qty. in pack 1 piece(s)	HEPA-HF-CT 26/36/48	65,55 78,66	<b>498994</b>
	for CT 11, 22, 33, 44, 55, qty. in pack 2 piece(s), in a carton	HF-CT/2	26,10 31,32	<b>452923</b>
	for CT 11, 22, 33, 44, 55, used only for extraction of dust types which are not hazardous to health, qty. in pack 2 piece(s), in a carton	Longlife-HF-CT/2	56,35 67,62	<b>454869</b>
	<b>Wet filter</b>			
	for CTL MINI/MIDI	NF-CT MINI/MIDI	8,75 10,50	<b>456805</b>
	for CT 26/36/48	NF-CT 26/36/48	12,00 14,40	<b>496169</b>
	for CT 11, 22, 33, 44, 55, qty. in pack 2 piece(s), in a carton	NF-CT/2	12,00 14,40	<b>452924</b>

## Dust extraction

### System accessories





#### for CT mobile dust extractors

#### CLEANTEC filter and filter bags

	Type	RRP in £*	Order no.
 <p><b>SELCLEAN filter bag</b> optimum usage of filter bag volume and constantly high suction power thanks to SELFCLEAN filter bag, qty. in pack 5 piece(s), in a carton</p>	for CTL MINI	SC FIS-CT MINI/5 13,85 16,62	<b>498410</b>
	for CTL MIDI	SC FIS-CT MIDI/5 20,20 24,24	<b>498411</b>
	for CT 26	SC FIS-CT 26/5 30,90 37,08	<b>496187</b>
	for CT 36	SC FIS-CT 36/5 34,00 40,80	<b>496186</b>
	for CT 48	SC FIS-CT 48/5 36,75 44,10	<b>497539</b>
	 <p><b>Disposable bag</b> not suitable for CT standard version (without AC), qty. in pack 5 piece(s), in a carton</p>	for CT 26 AC	ENS-CT 26 AC/5 27,20 32,64
for CT 36 AC/CTL 36 E AC HD		ENS-CT 36 AC/5 29,45 35,34	<b>496215</b>
for CT/CTL/CTM 48 AC		ENS-CT 48 AC/5 31,75 38,10	<b>497540</b>

### for CT mobile dust extractors



#### CLEANTEC filter and filter bags

		Type	RRP in £*	Order no.
	<b>Safety filter bag</b> double-layered, qty. in pack 3 piece(s), in a carton			
	for CTH 26	FIS-CTH 26/3	44,15 52,98	<b>497541</b>
	for CTH 48	FIS-CTH 48/3	49,70 59,64	<b>497542</b>
	<b>Longlife filter bag</b> used only for extraction of dust types which are not hazardous to health, from high strength, 3-layer polyester fleece with a long service life, in a carton			
	for CTL MINI	Longlife-FIS-CTL MINI	62,60 75,12	<b>499703</b>
	for CTL MIDI	Longlife-FIS-CTL MIDI	89,80 107,76	<b>499704</b>
	for CT 26	Longlife-FIS-CT 26	120,00 144,00	<b>496120</b>
	for CT 36	Longlife-FIS-CT 36	126,40 151,68	<b>496121</b>
	for CT 48	Longlife-FIS-CT 48	132,80 159,36	<b>498506</b>
	for CT 22, qty. in pack 5 piece(s)	FIS-CT 22/5	30,90 37,08	<b>452970</b>
	for CT 22, qty. in pack 20 piece(s)	FIS-CT 22/20	111,10 133,32	<b>494631</b>
	for CT 33, qty. in pack 5 piece(s)	FIS-CT 33/5	34,00 40,80	<b>452971</b>
	for CT 33, qty. in pack 20 piece(s)	FIS-CT 33/20	121,50 145,80	<b>494632</b>
	for CT 44, qty. in pack 5 piece(s)	FIS-CT 44/5	36,75 44,10	<b>452972</b>
	for CT 55, qty. in pack 5 piece(s)	FIS-CT 55/5	39,75 47,70	<b>452973</b>
	<b>Filter bag</b> with spunbond outer layer, extremely tearproof, for extracting fine dust particles qty. in pack 5 piece(s), in a carton			
for CT 22	FIS-CT 22 SP VLIES/5	39,85 47,82	<b>456870</b>	
for CT 33	FIS-CT 33 SP VLIES/5	43,75 52,50	<b>456871</b>	
for CT 44	FIS-CT 44 SP VLIES/5	47,35 56,82	<b>456874</b>	
	<b>Longlife filter bag</b> used only for extraction of dust types which are not hazardous to health, from high strength, 3-layer polyester fleece with a long service life, in a carton			
	for CT 22	Longlife-FIS-CT 22	120,00 144,00	<b>456737</b>
	for CT 33	Longlife-FIS-CT 33	126,40 151,68	<b>456738</b>

## Dust extraction

### System accessories

#### for SR extractors

SR filter		Type	RRP in £*	Order no.
	<b>Absolute filter</b> in a carton			
	for SRM 45 LE-EC, SRM 70 LE-EC	AB-FI SRM 45/70	47,25 56,70	<b>493826</b>
	for SRH 45, qty. in pack 1 piece(s)	AB-FI SRH 45	61,10 73,32	<b>493825</b>
	<b>Main filter</b> for SRM 45 E-PLANEX, Nano, in a carton	NANO HF-SRM 45-LHS 225	44,30 53,16	<b>496406</b>

#### for SR extractors

SR filter bags		Type	RRP in £*	Order no.
	<b>Filter bag</b> qty. in pack 5 piece(s), in a carton			
	for SRM 45 LE-EC	FIS-SRM 45 /5	36,65 43,98	<b>493775</b>
	for SRM 45 E-PLANEX	FIS-SRM 45-LHS 225 /5	30,05 36,06	<b>495014</b>
	for SRM 70 LE-EC	FIS-SRM 70 /5	47,45 56,94	<b>493777</b>
	for SRH 45 E	FIS-SRH 45 /5	125,00 150,00	<b>493776</b>



### for SR extractors

#### SR disposal bag



**Disposable bag**  
for SRM 45 E-PLANEX, qty. in pack 5 piece(s), in a carton

Type	RRP in £*	Order no.
ENS-SRM 45-LHS 225/5	26,25 31,50	<b>495015</b>

#### SR filters and filter bags for discontinued models



##### Absolute filter

for SR 5, SR 200, SR 201, in a carton

Type	RRP in £*	Order no.
AB-FI/U	33,55 40,26	<b>485808</b>

for SR151, in a carton

AB-FI	43,50 52,20	<b>488461</b>
-------	----------------	---------------

for SR 6, SR 12, SR 14, SR 202, SR 203, SR 212, SR 301, SR 302, SR 303,  
application category C/M, in a carton

AB-FI/C	45,85 55,02	<b>486241</b>
---------	----------------	---------------



##### Longlife pre-filter

used instead of FIS filter bags for coarse dirt, suitable for all SR extractors,  
except for SR 15, SRH 204, SRM 312, SRM 45/70, SRH 45, in a carton

VF-Multi	94,90 113,88	<b>451230</b>
----------	-----------------	---------------



##### Filter bag

qty. in pack 5 piece(s), in a carton  
for SR 5, SR 6, double-layered

FIS-SR 5/6 /5	34,45 41,34	<b>483143</b>
---------------	----------------	---------------

for SR 12, SR 14

FIS-SR 12/14 /5	43,65 52,38	<b>483142</b>
-----------------	----------------	---------------

for SR 151, SRM 152

FIS-SR 150 /5	34,45 41,34	<b>488460</b>
---------------	----------------	---------------



for SR 200, SR 201, SR 203

FIS-SR 200 /5	37,50 45,00	<b>487070</b>
---------------	----------------	---------------



for SR 301, SR 303, SRM 312

FIS-SR 300 /5	48,65 58,38	<b>487790</b>
---------------	----------------	---------------

for SR15, SR12, SR14, for substances with dust emission limits and carcinogenic  
substances as defined by GefStoffV35, BIA-approved

FIS-SR 15 /5	72,75 87,30	<b>483889</b>
--------------	----------------	---------------

for SR 202, SR 212, SRH 204, SR 200, SR 201, SR 203

FIS-SR 202 /5	64,35 77,22	<b>487482</b>
---------------	----------------	---------------

for SR 302, SR 301, SR 303, SRM 312

FIS-SR 302 /5	90,65 108,78	<b>488439</b>
---------------	-----------------	---------------

## Dust extraction



### System accessories

#### for CT mobile dust extractors and SR dust extractors

CT accessories	Type	RRP in £*	Order no.
 <p><b>Hose holder</b> for CT 11, 22, 33, 44, 55, for storing the suction hose and mains cable, suitable hose sizes: plug it hose D 22 x 3.5 m / D 27 x 3.5 m / D 27 x 5 m / D 36 x 3.5 m / D 50 x 2.5 m / IAS 2-3500 AS, Dimensions [L x W x H] 530 x 360 x 110 mm, in a carton</p>	CT-SG	36,75 44,10	<b>494388</b>
 <p><b>Tool holder</b> in a carton</p>			
<p>for CT 36 PLANEX, with practical carrier handle, for storing PLANEX</p>	WHR-CT 36-LHS 225	81,35 97,62	<b>495964</b>
 <p>for SRM 45 E-PLANEX</p>	WHR/SRM 45-LHS 225	81,35 97,62	<b>495155</b>
 <p>for CT 26/36, galvanised steel tool holder for sanders, for stable and ergonomic placement of an electrical or compressed air power tool</p>	WHR-CT	38,70 46,44	<b>496122</b>
<p><b>Handle</b> for the convenient transportation of mobile dust extractors, in a carton</p>			
 <p>for CT 11, 22, 33, 44, 55</p>	SB-CT	75,05 90,06	<b>452921</b>
 <p>for CT 26/36, with nozzle holder</p>	SB-CT 26/36	58,70 70,44	<b>495802</b>
 <p>for CT 48, with nozzle holder</p>	SB-CT 48	136,80 164,16	<b>497295</b>
 <p><b>Hose holder</b> for CT 11, 22, 26, 33, 36, 44, 55, eliminates the trip hazard of hoses on the floor, in a carton</p>	SHR-CT/SR	27,10 32,52	<b>487072</b>
 <p><b>Sealing slide</b> for CT AC / CT 36 AC PLANEX, ensures extreme vacuum in container, the filter undergoes thorough cleaning, in a carton</p>	VS-CT AC/SRM45 PLANEX	38,00 45,60	<b>497926</b>
 <p><b>Adapter</b> adapter for attaching the WCR and/or service unit VE CT 26/36/48 for CT 48 EC and CT 48 EC B22, in a carton</p>	AD-WCR	47,10 56,52	<b>498805</b>
 <p><b>Vacuum clamping nozzle</b> for CT mobile dust extractors and D 27 suction hose, flexible aid for temporary clamping and fixing of workpieces at horizontal and vertical areas, max. clamping height 50 mm, max. load 3 kg, Dimensions [L x W x H] 130 x 80 x 50 mm, weight 0,35 kg</p>	CT-W	28,45 34,14	<b>500312</b>

### for CT mobile dust extractors and SR dust extractors

#### CT compressed air accessories

		Type	RRP in £*	Order no.
	<b>Compressed air module</b> to convert the CT mobile extractor, model E to LE design with additional automatic on/off switch for air tools, only suitable for CT 22/33/44, in a carton	DLM-CT	140,60 168,72	<b>452829</b>
	<b>Service unit</b> in a carton			
	not for the CT 11/CT MINI/CT MIDI, for LE versions of CT 22/33/44/55, consisting of a quick condensate drain, pressure regulator, oiler and oil-free compressed air outlet with quick coupling, for the CT 22/33, can only be installed with the SB-CT handle	VE-CT	347,90 417,48	<b>452797</b>
	for LE version of CT 26/36/48, condensate quick discharge, pressure controller, oiler and oil-free compressed air outlet with quick coupling	VE-CT 26/36/48	347,90 417,48	<b>495886</b>

#### SR compressed air accessories

		Type	RRP in £*	Order no.
	<b>Service unit</b> for SRM 45/SRM 70 LE-EC, for cleaning compressed air	VE-SRM 45/70	363,40 436,08	<b>499524</b>





## Stirring

---

**Overview of products and applications** 300

---

**Stirrers** MX 1000, MX 1000/2, MX 1200, MX 1200/2, MX 1600/2 303

**Duo stirrers** MX 1600/2 DUO 305

---

**Accessories and consumable materials** 306

---

The Festool system

# Stirring

## Overview of products and applications

Page 303 ————— 303 ————— 303

Our stirrers revolve around the most important requirements in your daily stirring and mixing applications: sturdiness, durability, constant power under load and outstanding ergonomics.

MX 1000

MX 1000/2

MX 1200



### Applications

### Stirrers

#### Mixing and stirring

Liquid materials: paints, clear coats, wallpaper paste



Viscous materials: filling mixtures and smoothing cement



Stiff, compact materials: plaster, tile cement, mortar



#### Mixing volume

up to 40 l



up to 70 l



up to 90 l



#### Technical data

Power consumption (W)	1020	1020	1200
Idling speed, 1st gear (rpm)	360-630	360-630	360-630
Idling speed, 2nd gear (rpm)		582-1010	
Tool reception	M14/ErgoFix	M14/ErgoFix	M14/ErgoFix
Clamping collar diameter (mm)	57	57	57
Max. stirrer basket diameter (mm)	120	120	140
Weight (kg)	4,5	4,9	4,5

304 ——— 304 ——— 305

MX 1200/2

MX 1600/2

MX 1600/2 DUO



Stirrers

DUO\_stirrers



Extremely appropriate  Appropriate

	1200	1500	1500
	150-360	150-300	100-250
	320-780	320-650	130-350
	M14/ErgoFix	M14/ErgoFix	FastFix
	57	57	57
	140	160	140
	6,2	6,4	7,9

## Stirring

### Maintains its position.

Stooped over mixing is now a thing of the past: The size of the MX stirrers can be adapted with the ErgoFix height adjustment. You work upright, protect your back and can completely rely on the powerful engines, which ensure intensive and quick mixing. For in between usage the stirrers have anti-slip rubber corners for positioning against the wall. And after the work is completed, they are easy to clean and transport – the machine and stirrer can be disconnected without the need for any tools.



### Ergonomic – mix while standing upright.

Simply adjust the stirrer to match your height with the patented ErgoFix height adjustment system. Mix in a natural upright position for relaxed and effortless working.



### One for all.

The ErgoFix adapter has a classic M14 tool holder so that all current stirrer baskets can be used. In addition, it is designed for the entire service life of the stirrer thanks to its special coating.



### Lightning quick changes without using tools.

The FastFix quick-change system allows the detachment of the stirrer basket from the machine and rapid basket changes without the need for tools, easy cleaning and space-saving transportation.







MX 1000 / MX 1000/2 / MX 1200

### Robust, ergonomic, powerful.

- ▶ ErgoFix height adjustment with integrated quick-change function
- ▶ No material splash upon start-up thanks to soft start with variable speed trigger
- ▶ Less effort required for guiding the stirrer thanks to ergonomic handle design with large lever arm
- ▶ Powerful motor with power electronics for constant power development



Technical data	MX 1000	MX 1000/2	MX 1200
Power consumption (W)	1020	1020	1200
Idling speed, 1st gear/2nd gear (min <sup>-1</sup> )	360-630/-	360-630/582-1010	360-630/-
Tool reception	M14/ErgoFix	M14/ErgoFix	M14/ErgoFix
Collar Ø (mm)	57	57	57
Max. mixer container diameter (mm)	120	120	140
Mix quantity (l)	40	40	60
weight (kg)	4,5	4,9	4,5



■ = with MMC electronics

This product is not available in Great Britain.

### Powerful.

Powerful motors combined with a perfectly adapted gear unit ensure a constant performance under load, can tackle even the most demanding mixing applications and withstand long periods of continuous use.

10

System accessories  
from page 308



## Stirring

Stirrers MX 1200/2, MX 1600/2



# MX 1200/2 / MX 1600/2



### Extremely sturdy design.

Whether it is stubborn dirt, hard impacts or collisions – the new stirrers can withstand the toughest of conditions thanks to the longlife drive, solid tubular steel frame and rubber edges.

### Extremely powerful for harsh industrial environments.

- ▶ For tough and heavy material with high torque, 2-gear transmission
- ▶ ErgoFix height adjustment with integrated quick-change function
- ▶ Less effort required for guiding the stirrer thanks to ergonomic handle design with large lever arm
- ▶ Powerful motor with power electronics for constant power development

Technical data	MX 1200/2	MX 1600/2
Power consumption (W)	1200	1500
Idling speed, 1st gear/2nd gear (min <sup>-1</sup> )	150-360/320-780	150-300/320-650
Tool reception	M14/ErgoFix	M14/ErgoFix
Collar Ø (mm)	57	57
Max. mixer container diameter (mm)	140	160
Mix quantity (l)	70	90
weight (kg)	6,2	6,4



= with MMC electronics

This product is not available in Great Britain.

System accessories  
from page 308





# MX 1600/2 DUO



### DUO stirrer: Quicker, easier, more intensive.

- ▶ Quicker at lower power thanks to mixing tools working in opposite direction
- ▶ Intensive and thorough mixing process with combing effect
- ▶ Quick change of stirring rod with FastFix system
- ▶ Electronic control and 2-gear manual transmission: The correct speed for every material

#### Technical data

Power consumption (W)	1500
Idling speed, 1st gear/2nd gear (min <sup>-1</sup> )	100-250/130-350
Tool reception	FastFix
Collar Ø (mm)	57
Max. mixer container diameter (mm)	140
Spindle pitch (mm)	110
Mix quantity (l)	90
weight (kg)	7,9



■ = with MMC electronics

This product is not available in Great Britain.

### Stationary application.

The DUO stirrer becomes the complete mixing station in the MS 57 stirrer stand. While you process the already mixed material, the next quantity is already being prepared in the stirrer stand.

System accessories  
from page 308



### The Festool system.

Because it's simply better when everything fits together: The right stirrer for every application. With the FastFix quick-change system, the stirrer basket can be changed easily and quickly for different materials.



## Stirring

Accessories and consumable materials

### System accessories

Stirrer rods	309
Adapter	311
Mixing centre, stirrer	311



# Stirring

## Stirrer rods

The ultimate solution for every mixing task.



**PJ Uni**      **RS Round stirrer**      **WS Disc stirrer**      **HS3L Helical stirrer with 3 anticlockwise spirals**      **CS Whisk**      **HS2 Helical stirrer with 2 spirals**      **HS3R Helical stirrer with 3 clockwise spirals**

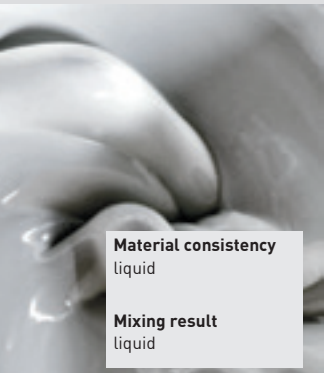

**Material consistency**  
liquid

**Mixing result**  
liquid

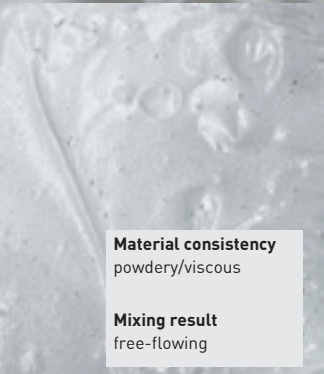

**Material consistency**  
powdery/viscous

**Mixing result**  
free-flowing







**Material consistency**  
powdery/viscous

**Mixing result**  
compact

	PJ Uni	RS Round stirrer	WS Disc stirrer	HS3L Helical stirrer with 3 anticlockwise spirals	CS Whisk	HS2 Helical stirrer with 2 spirals	HS3R Helical stirrer with 3 clockwise spirals
Paints	●	●	●	●			
Emulsion paint	●	○	●	●			
Wallpaper paste	●	○	○	○			
Clear coat, varnish	●	●	●	○			
Epoxy resin	○	○	○	○	●		
Filler					●	●	○
Bonding mortar					○	●	○
Levelling compound	○				●	○	
Waterproofing filler					●	●	○
Bitumen					○		○
Ready-mix plaster	●					○	○
Plaster				○		●	●
Tile cement						●	○
Joint mortar						●	●
Mortar						●	●
Quartz-filled epoxy resin						○	●
Concrete, screed						○	●





● Extremely appropriate      ○ Very appropriate

### Stirrer rods

		Type	RRP in £*	Order no.
	<b>ProJet Uni</b> ideal for organic products, wall and emulsion paints, ready-mix smoothing cement and plaster, adhesives, clear coats/varnish, Length 600 mm			
	for MX 1000, MX 1000/2, MXP 800, MXP 1000, MXP 1002, material quantity 10-20 kg, Diameter 140 mm	PJ UNI 140x600 M14	-	<b>769072</b>
	for MX 1200, MX 1200/2, MXP 1200, MXP 1202, material quantity 15-30 kg, Diameter 160 mm	PJ UNI 160x600 M14	-	<b>769073</b>
	for MX 1600/2, MXP 1602, material quantity 20-60 kg, Diameter 180 mm	PJ UNI 180x600 M14	-	<b>769074</b>
	<b>Round stirrers</b> for fluid materials, wall and emulsion paints, standard paste, sealing compounds, clear coats, bitumen, sludge			
	for chuck with clamping range >10mm, material quantity -15 kg, Diameter 85 mm, Length 400 mm	RS 2 85x400 SW 8	-	<b>769023</b>
	for chuck with clamping range >13mm, material quantity 15-25 kg, Diameter 100 mm, Length 600 mm	RS 2 100x600 SW 10	-	<b>769024</b>
	for MX 1000, MX 1000/2, MXP 800, MXP 1000, MXP 1002, material quantity 15-25 kg, Diameter 100 mm, Length 600 mm	RS 2 100x600 M14	-	<b>769020</b>
	for MX 1000, MX 1000/2, MXP 800, MXP 1000, MXP 1002, material quantity 20-40 kg, Diameter 120 mm, Length 600 mm	RS 2 120x600 M14	-	<b>769021</b>
	<b>Disc stirrer</b> for liquid materials, paints, varnishes, wall paint, emulsion paint, wallpaper paste, glue, tile cement			
	for chuck with clamping range >10mm, material quantity -5 kg, Diameter 60 mm, Length 350 mm	WS 2 60x350 SW 8	-	<b>769033</b>
	for chuck with clamping range >10mm, material quantity 5-10 kg, Diameter 80 mm, Length 350 mm	WS 2 80x350 SW 8	-	<b>769034</b>
	for chuck with clamping range >13mm, material quantity 10-15 kg, Diameter 100 mm, Length 600 mm	WS 2 100x600 SW 10	-	<b>769035</b>
	<b>Disc stirrer</b> for liquid materials, paints, varnishes, wall paint, emulsion paint, wallpaper paste, glue, tile cement, Length 600 mm			
	for MX 1000, MX 1000/2, MXP 800, MXP 1000, MXP 1002, material quantity 15-20 kg, Diameter 120 mm	WS 2 120x600 M14	-	<b>768122</b>
	for MX 1200, MX 1200/2, MXP 1200, MXP 1202, material quantity 20-30 kg, Diameter 140 mm	WS 2 140x600 M 14	-	<b>769022</b>
	for MX 1600/2, MXP 1602, material quantity 30-60 kg, Diameter 160 mm	WS 2 160x600 M 14	-	<b>769036</b>
	<b>Spiral stirrer</b> for thin materials, gypsum plaster, emulsion paint, clear coats, wall paints, sealing compounds, Length 600 mm			
	for MX 1000, MX 1000/2, MXP 800, MXP 1000, MXP 1002, material quantity 15-25 kg, Diameter 120 mm	HS 3 120x600 L M14	-	<b>767921</b>
	for MX 1200, MX 1200/2, MXP 1200, MXP 1202, material quantity 25-40 kg, Diameter 140 mm	HS 3 140x600 L M14	-	<b>768138</b>
	for MX 1600/2, MXP 1602, material quantity 30-60 kg, Diameter 160 mm	HS 3 160x600 L M14	-	<b>768709</b>

# Stirring

## System accessories

Stirrer rods		Type	RRP in £*	Order no.
	<b>Stirrer</b> Length 600 mm			
	for chuck with clamping range >13mm, material quantity 10-25 kg, Diameter 120 mm	CS 120x600 SW10	- -	<b>769119</b>
	for MX 1000, MX 1000/2, MXP 800, MXP 1000, MXP 1002, material quantity 10-15 kg, Diameter 120 mm	CS 120x600 M14	- -	<b>769118</b>
	for MX 1200, MX 1200/2, MXP 1200, MXP 1202, material quantity 20-40 kg, Diameter 140 mm	CS 140x600 M14	- -	<b>769117</b>
	for MX 1600/2, MXP 1602, material quantity 40-60 kg, Diameter 160 mm	CS 160x600 M14	- -	<b>769116</b>
	<b>Spiral stirrer</b> for chuck with clamping range >10mm, Length 400 mm			
	material quantity <8 kg, Diameter 70 mm	HS 2 70x400 SW 8	- -	<b>769025</b>
	material quantity 8-10 kg, Diameter 85 mm	HS 2 85x400 SW 8	- -	<b>769026</b>
	<b>Spiral stirrer</b>			
	for chuck with clamping range >10mm, material quantity 10-15 kg, Diameter 100 mm, Length 400 mm	HS 2 100x400 SW 8	- -	<b>769027</b>
	for chuck with clamping range >13mm, material quantity 15-20 kg, Diameter 120 mm, Length 600 mm	HS 2 120x600 SW 10	- -	<b>769028</b>
	for chuck with clamping range >13mm, material quantity 20-40 kg, Diameter 140 mm, Length 600 mm	HS 2 140x600 SW 12	- -	<b>769029</b>
	for MX 1000, MX 1000/2, MXP 800, MXP 1000, MXP 1002, material quantity 15-20 kg, Diameter 120 mm, Length 600 mm	HS 2 120x600 M14	- -	<b>769030</b>
	for MX 1200, MX 1200/2, MXP 1200, MXP 1202, material quantity 20-40 kg, Diameter 140 mm, Length 600 mm	HS 2 140x600 M14	- -	<b>769031</b>
	for MX 1600/2, MXP 1602, material quantity 30-60 kg, Diameter 160 mm, Length 600 mm	HS 2 160x600 M14	- -	<b>769032</b>
	<b>Spiral stirrer</b> Length 600 mm			
	for MX 1000, MX 1000/2, MXP 800, MXP 1000, MXP 1002, material quantity 15-25 kg, Diameter 120 mm	HS 3 120x600 R M14	- -	<b>767887</b>
	for MX 1200, MX 1200/2, MXP 1200, MXP 1202, material quantity 25-40 kg, Diameter 140 mm	HS 3 140x600 R M14	- -	<b>768708</b>
	for MX 1600/2, MXP 1602, material quantity 30-60 kg, Diameter 160 mm	HS 3 160x600 R M14	- -	<b>768710</b>



Stirring rods for MX 1600/2 EQ DUO		Type	RRP in £*	Order no.
	<b>Stirring rod</b> for MX 1600/2 DUO, MXP 1602 DUO, for liquid and viscous materials, lower part of the stirrer cage raises mixture from the bottom of the container upwards. Upper part of the stirrer cage pushes mixture downwards, Diameter 140 mm, Length 600 mm, in a carton	HS 3 COMBI 140x600 FF	- -	<b>768092</b>
	<b>Stirring rod</b> for MX 1600/2 DUO, MXP 1602 DUO, For high viscosity or heavy materials needing thorough mixing, two stirrer rods, each with three helices, counter-rotate. Mixture is pulverised and whisked, Diameter 140 mm, Length 600 mm, in a carton	HS 3 DOUBLE 140x600 FF	- -	<b>768800</b>





### ErgoFix adapter

		Type	RRP in £*	Order no.
	<b>Adapter</b> with M14 thread, For holding Festool stirrer rods M14 at ErgoFix stirrers, stroke length 80 mm	AD-EF-M14/80 ErgoFix	-	769091

### Adapters and extensions

		Type	RRP in £*	Order no.
	<b>Adapter</b> fitting stirrer rods with internal thread	MA M14-M14	-	769148
	Clamping drill chuck 5/8" to stirrer	MA M14-5/8" x 16	-	769149
	fitting 1/2" chucks to stirrers	MA M14-1/2" x 20	-	769150
	connects Festool stirring rod with M 14 external thread to stirrer (RW 1000) with external thread	MAI M14-M14	-	769151
	for drills with 5/8" holder – 16 UNF, fitting Festool stirrer rods to drills	MAI M14-5/8" x 16	-	769153
	for drills with 1/2" holder – 20 UNF, fitting Festool stirrer rods to drills	MAI M14-1/2" x 20	-	769152
	for extending all stirrer rods by 400 mm, thread M14, M14 thread on both ends	PL 400 M14/M14	-	769037

### Mixing centre, stirrer

		Type	RRP in £*	Order no.
	<b>Stirrer stand</b> excellent stability and reliability due to the robust zinc-coated steel construction, the stand can be simply disassembled for easy transport, stirrer stand with safety switch, 4 m power cord, spindle reception 57 mm, clamp for attachment collar 57 mm, length x width 950 x 550 mm, height adjustable 1000-1520 mm, max. Ø mixture container 400 mm, weight 30 kg, in a carton	MS 57	-	769039
	<b>Fixed rod</b> for attaching mixing containers to the stirrer stand MS 57, Suitable for container heights between 300 mm and 500 mm, in a carton	CL-MS	-	769048
	<b>Adapter ring</b> for holding stirrers with a collar dia. 43 mm in MS 57	A-GD 57/43	-	768712





## Renovation, refurbishment and drywalling

# 11

**Overview of products and applications** 314

**RENOFIX renovation millers** RG 80, RG 150 317

**Diamond grinders RENOFIX** RG 130 319

**Diamant grinding system** DSG-AG 125, DSC-AG 125, DSC-AG 230 320

**Long-reach sander** LHS 225 321

**Carpet remover** TPE 322

**Wallpaper perforator** TP 220 323

**Accessories and consumable materials** 324

The Festool system

11

 **SERVICE**  
all-inclusive

# Renovation, refurbishment and drywalling

## Overview of products and applications

Concrete, stone, plaster, adhesive, paint and other old coatings can often only be removed with great effort. That's why there is the RENOFIX renovation millers, with which you can easily master all challenges in material removal capacity.

Page

317

318

RG 80



RG 150



### Renovation miller RENOFIX



### Applications

#### Plaster

- Milling off mineral/soft plaster on walls and façades
- Milling off hard (cement) plaster on walls and façades
- Milling off synthetic resin plaster

#### Adhesive

- Removing tile adhesive/adhesive residue
- Removing elasticised adhesive for PVC or wooden flooring

#### Concrete

- Grinding unset concrete area/parts
- Light grinding of weathered and cured concrete areas
- Roughing up smooth surfaces on concrete
- Grinding very hard concrete (C30/37 and harder)
- Sanding off for levelling unevenness on cured concrete

#### Colour

- Removing latex paints, oil-based paints and paint coatings on plaster
- Removing concrete paint on concrete surfaces
- Removing elasticised protective coating

#### Coatings

- Removing bitumen
- Removing PU coatings
- Levelling unevenness on screed flooring
- Removing epoxy resin coatings
- Removing impaired fillers

#### Others

- Light sanding/Roughing of Terazzo/tiles

### Technical data

Power consumption (W)	1100	1600
Idle engine speed (rpm)	2000-5900	1000-2200
Disc Ø (mm)		
Tool diameter (mm)	80	150
Connection Ø d/e (mm)	36	36
Tool reception	2 x M5	D14/M8
Weight (kg)	3,2	5,5

# Renovation, refurbishment and drywalling

## Overview of products and applications

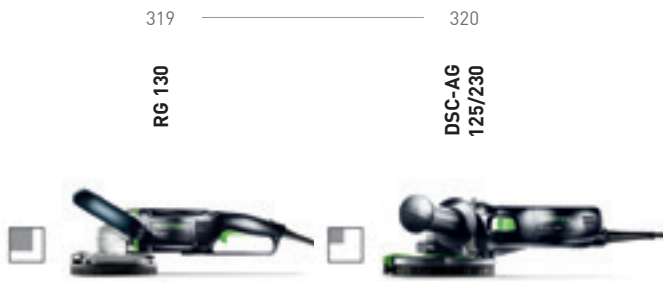

### Diamond grinders RENOFIX

### Diamant grinding system

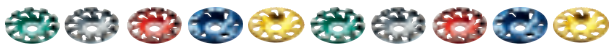

DIA STONE DIA HARD DIA ABRESIV DIA THERMO DIA UNI  
 DIA STONE DIA HARD DIA ABRESIV DIA THERMO DIA UNI

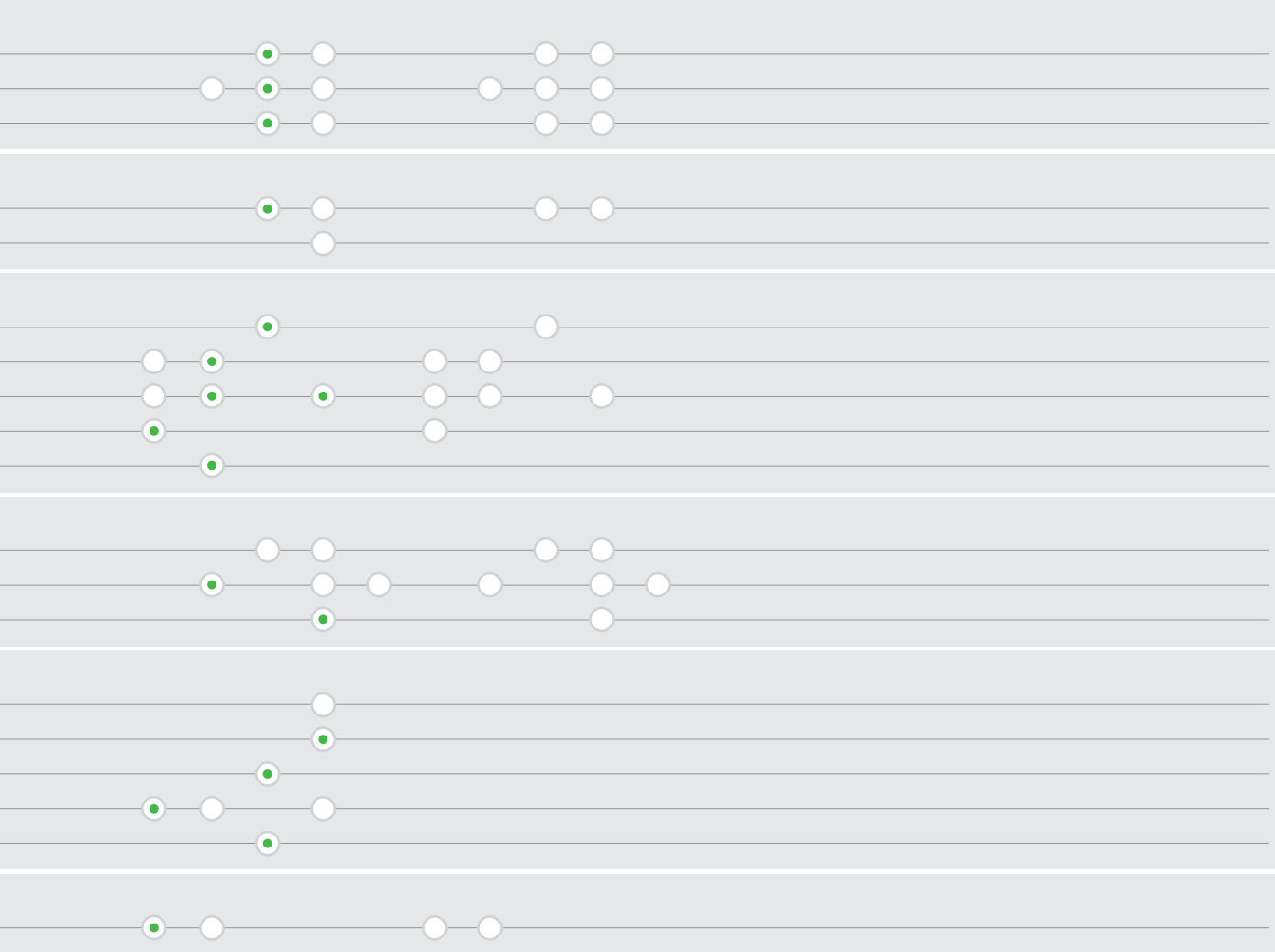

Suitable for areas in size shown, by comparison

Extremely appropriate

Appropriate

1600	1400
3000-7700	3500-11000
	125/130
130	
36	36/27
D25/M14	
3,8	2,7

# Renovation, refurbishment and drywalling

## Overview of products and applications

Removing carpet or wallpaper, sanding plasterboard – materials and requirements in the area of refurbishment, drywalling and renovation are diverse. Festool offers a wide range of solutions, incorporated in a complete system of accessories and consumables.

Page 321 — 322 — 323 — 210 — 210

LHS 225

TPE

TP 220

DWC 18-2500

DWC 18-4500



### Applications

Long-reach sander

Carpet remover

Wallpaper perforator

Cordless drywall screwdriver

### Drywalling

Sanding plasterboard and dry wall filler

Sanding set filler

Sanding filler on high ceilings

Screwing in plasterboards – wooden substructure

Screwing in plasterboards – sheet metal substructure



### Renovation and refurbishment

Removing wallpaper

Removing wallpaper residues

Carpet removal

Removing backing and adhesive layers



Extremely appropriate  Appropriate

### Technical data

Power consumption (W)	550	620			
Idle engine speed (rpm)	340-910	6000		0-2500	0-4500
No. of strokes (rpm)		12000			
Sanding stroke		5			
Weight (Length 1.10 m) (kg)	3,8				
Weight (Length 1.60 m) (kg)	4,6				
Weight (kg)		3,6	1,5	2,1	2,1

# RENOFIX RG 80



### The universal machine for walls, ceilings and floors.

- ▶ Constant speed under load due to MMC Electronic
- ▶ Electronic monitoring of winding temperature, prevents thermal deterioration of the motor
- ▶ Regulated electronics for constant speed
- ▶ Supporting base with smooth cutting 0 – 3.5 mm depth adjustment for safe operation

#### Technical data

Power consumption [W]	1100
Idle engine speed [min <sup>-1</sup> ]	2000-5900
Tool Ø [mm]	80
Tool reception	2 x M5
Connection Ø d/e [mm]	36
weight [kg]	3,2



■ = with electronics

This product is not available in Great Britain.

### One for all.

The RG 80 renovation miller is a multitasking tool for medium-sized and larger areas.

Thanks to the wide range of accessories, you can effortlessly remove hard and soft materials. Adhesives, paint and coatings, synthetic resin plaster, porous concrete and sand-lime brick on flooring, walls and ceilings can be removed easily and quickly.

System accessories  
from page 326

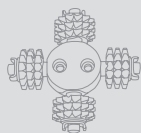

Mobile dust extractors  
from page 275



## Renovation, refurbishment and drywalling

Renovation miller RENOFIX RG 150



# RENOFIX RG 150



### The all-rounder for large areas.

The RG 150 renovation miller is your perfect partner for large areas thanks to the 150 mm tool diameter and a wide range of accessories. In conjunction with the laminate, screed, coatings and adhesive residue can be removed effectively. The ergonomic double grip in a D shape sits perfectly in the hands in every work position.

### The Large Space Ace.

- ▶ Renovation miller operates at the perfect speed for machining soft materials over large surface areas
- ▶ Robust and powerful 1,600 W motor
- ▶ "D" handles for safe, comfortable handling
- ▶ Efficient dust extraction and automatic seal with guard

#### Technical data

Power consumption (W)	1600
Idle engine speed (min <sup>-1</sup> )	1000-2200
Tool Ø (mm)	150
Tool reception	D14/M8
Connection Ø d/e (mm)	36
weight (kg)	5,5



= with electronics

This product is not available in Great Britain.

System accessories  
from page 327



Mobile dust extractors  
from page 275





## Renovation, refurbishment and drywalling

### Diamond grinder RENOFIX RG 130



## RENOFIX RG 130



### The ace of diamonds.

- ▶ Diamond grinder operates at the perfect speed for diamond tools
- ▶ 1,600 W motor for rapid material removal and working progress
- ▶ Folding segment allows you to work directly on walls
- ▶ Reliable guidance and adjustable, defined material removal with guide table

#### Technical data

Power consumption (W)	1600
Idle engine speed (min <sup>-1</sup> )	3000-7700
Tool Ø (mm)	130
Tool reception	D25/M14
Connection Ø d/e (mm)	36
weight (kg)	3,8



■ = with electronics

This product is not available in Great Britain.

### The ace of diamonds.

The RG 130 diamond grinder is the ace in material removal on larger areas. The optimised speed for diamond tools enables quick removal of concrete, screed and coatings on hard substrate. The folding cover segment which can be removed without any tools allows working right into edges and corners. Thanks to the patented extraction spiral, excellent dust extraction results are guaranteed.

System accessories  
from page 328



Mobile dust extractors  
from page 275



## Renovation, refurbishment and drywalling

Diamant grinding system DSG-AG 125 /

Diamond cutting system DSC-AG 125 / DSC-AG 230



DSG-AG 125 / DSC-AG 125 / DSC-AG 230



### The compact angle grinding system.

With the grinding system Festool provides a compact system for virtually dust-free grinding. Unevenness can be levelled, paints, concrete, adhesive and plaster can be removed and surfaces prepared for new coatings. The folding front segment enables working right into edges and corners.

### Diamant sanding system – dust-free working with the DSG-AG.

- ▶ FastFix system for quick and easy removal and attachment of the guard
- ▶ Sliding segment for working close to edges
- ▶ Brush ring for efficient dust extraction

Technical data	DSG-AG 125	DSC-AG 125	DSC-AG 230
Power consumption (W)	1400	1400	2600
Idle engine speed (min <sup>-1</sup> )	3500-11000	11000	6500
Disc Ø (mm)	125/130	125	230
Connection Ø d/e (mm)	36/27	36/27	36/27
Weight of guard/system (kg)	0,4/2,7	2,2/4,1	3,2/8,9

This product is not available in Great Britain.

System accessories  
from page 329



Mobile dust extractors  
from page 275





product  
design  
award

2008



# PLANEX LHS 225

### Efficient short-reach or long-reach sanding on walls and ceilings.

- ▶ Two lengths, one machine – extend or reduce in a few simple hand movements
- ▶ Two-speed gears for efficient, rapid material removal on walls and ceilings
- ▶ Robust, reliable drive components and efficient power transfer
- ▶ Adjustable suction power decreases the perceived weight of the machine

#### Technical data

Power consumption [W]	550
Idle engine speed [min <sup>-1</sup> ]	340-910
Interchangeable sanding pad Ø (mm)	215
Connection Ø d/e (mm)	36/27
Weight (length 1.60m) (kg)	4,6
Weight (length 1.10m) (kg)	3,8



☐ = with MMC electronics

Items Included	RRP in £*	Order no.
StickFix sanding pad Ø 215 mm, in a SYSTAINER SYS MAXI		
<b>LHS 225 EQ-Plus/IP GB 110V</b>	862,00	<b>571720</b>
2 Interface pads	1.034,40	
<b>LHS 225-IP/CTM 36-Set GB 110V</b>	1.575,00	<b>571832</b>
2 Interface pads, PLANEX tool holder, mobile dust extractor CTM 36E AC PLANEX	1.890,00	
<b>LHS 225/CTM 36 E AC-Set</b>	1.575,00	<b>571703</b>
mobile dust extractor CTM 36E AC PLANEX	1.890,00	



### Working near edges.

When sanding the area between two adjacent walls or a ceiling and wall, the PLANEX LHS 225 produces absolutely consistent results when sanding right up to the edge because of its removable brush segment.

\* Recommended retail price of manufacturer. Dealer prices may vary.  
Excl. VAT.  
Incl. VAT.

#### System accessories from page 330



#### Abrasives from page 116



#### Watch the product video



## Renovation, refurbishment and drywalling

### Carpet remover TPE-RS 100

TPE



#### Wear-resistant blade.

The carpet blade moves back and forth, doing all the hard work for you. Always reliable, easy to sharpen. It quickly works its way in between the sublayer and the adhesive layer. All you have to do is push forwards slightly. Saving time has never been easier.



#### Quick and easy.

- ▶ Hand-held use for awkward spots and stairs
- ▶ Extension handle for non-tiring work over large areas
- ▶ Powerful stirring action and reduction gearing for maximum economic efficiency
- ▶ High area capacity: 25 m<sup>2</sup> per hour on compact foam-backed carpets

#### Technical data

Power consumption (W)	620
Idle engine speed (min <sup>-1</sup> )	6000
No. of strokes (min <sup>-1</sup> )	12000
Sanding stroke (mm)	5
Blade width (mm)	195
weight (kg)	3,6



Items Included	RRP in £*	Order no.
in a SYSTAINER SYS 3 T-LOC		
<b>TPE-RS 100 Q-Plus GB 240V</b>	521,00 625,20	<b>567886</b>

\* Recommended retail price of manufacturer. Dealer prices may vary.  
Excl. VAT.  
Incl. VAT.

System accessories  
from page 331





# TP 220

### Attacks the wallpaper. Then removes it.

- ▶ Little effort is required because of the completely new working principle
- ▶ The adjustable penetration depth of the rollers protects the subsurface from being damaged
- ▶ The adjustable telescoping handle is perfect for working in rooms with high walls and on ceilings
- ▶ Protective cover for safe and clean transport



Technical data	
Telescoping handle length (m)	0,9-1,3
Depth adjuster (mm)	3,5
Cutting diameter (mm)	45
Dimensions (L x W x H) (mm)	168 x 224 x 52
weight (kg)	1,5

Items Included	RRP in £*	Order no.
protective cover, telescoping handle, in a carton		
<b>TP 220</b>	126,00 151,20	<b>495747</b>



### Completely new working principle.

Rollers rotating at different speeds create funnel-shaped openings so that water (blue in illustration) can flow in behind and then seep into the wallpaper (green in illustration).

\* Recommended retail price of manufacturer. Dealer prices may vary.  
Excl. VAT.  
Incl. VAT.

**System accessories  
from page 331**



### The Festool system.

Because it's simply better when everything fits together:  
The comprehensive system accessories for refurbishment, dry-walling and renovation provide the appropriate and dust-free solution for removing concrete, stone, plaster, adhesive, paint, carpet and wallpaper. Festool has the appropriate solution in its portfolio, starting with the correct tool heads for processing various substances with RENOFIX devices through to the exemplary mobile dust extractors for renovation millers and the PLANEX long-reach sander.



## Renovation, refurbishment and drywalling

Accessories and consumable materials

System accessories RG 80	326
System accessories RG 150	327
System accessories RG 130	328
System accessories DSG-AG 125	329
System accessories PLANEX LHS 225	330
System accessories TP 220, TPE	331



# Renovation, refurbishment and drywalling

## System accessories

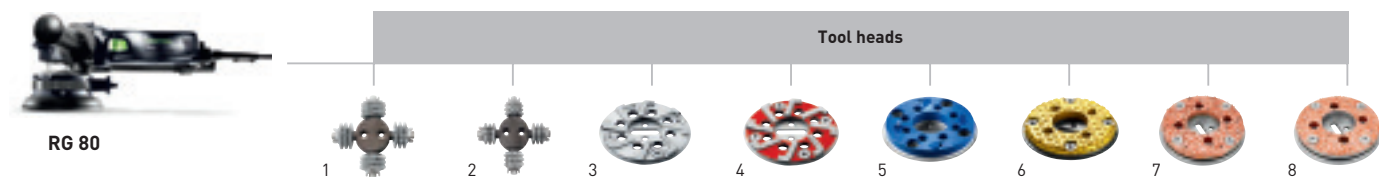

### Accessories for renovation miller RG 80 E

Denomination	Explanation	RRP in £*	Order no.
<b>1 Machine/tool head SZ-RG 80</b>	for RG 80, RGP 80, for hard plaster, adhesive residues and synthetic resin plaster, Diameter 80 mm, in self-service display pack	-	<b>767982</b>
<b>Cutter wheel HW-SZ 12</b>	12 carbide milling heads with "pointed teeth", replacement heads for SZ-RG 80, complete set with spacer discs and clamping elements, in self-service display pack	-	<b>769132</b>
<b>2 Machine/tool head FZ-RG 80</b>	for RG 80, RGP 80, for soft plaster, fresh concrete, adhesive residues and protective coatings, 12 carbide cutter wheels "flat", Diameter 80 mm, in self-service display pack	-	<b>769131</b>
<b>Cutter wheel HW-FZ 12</b>	12 "flat" carbide-tipped milling heads, replacement heads for FZ-RG 80, complete set with spacer discs and clamping elements, in self-service display pack	-	<b>769133</b>
<b>3 Machine/tool head DIA HARD-RG 80</b>	for RG 80, RGP 80, for old solid concrete, removal of epoxy resin from solid surfaces or coatings/paints from concrete, tool head with hard diamond disc, Diameter 80 mm, in self-service display pack	-	<b>767983</b>
<b>Diamond disc DIA HARD-D80</b>	replacement disc for tool head DIA HARD-RG 80, Diameter 80 mm, in self-service display pack	-	<b>769054</b>
<b>4 Machine/tool head DIA ABRASIVE-RG 80</b>	for RG 80, RGP 80, for sand-based materials, screed, fresh concrete, adhesive on screed, sand-lime brick and cellular concrete, tool head with abrasive diamond disc, Diameter 80 mm, in self-service display pack	-	<b>767984</b>
<b>Diamond disc DIA ABRASIVE-D80</b>	replacement disc for tool head DIA ABRASIV-RG 80, Diameter 80 mm, in self-service display pack	-	<b>769055</b>
<b>5 Machine/tool head DIA THERMO-RG 80</b>	for RG 80, RGP 80, For thermoelastic materials on concrete, screed, etc., tool head with THERMO diamond disc, Diameter 80 mm, in self-service display pack	-	<b>769082</b>
<b>Diamond disc DIA-THERMO 80</b>	replacement disc for tool head DIA THERMO-RG 80, Diameter 80 mm, in self-service display pack	-	<b>769084</b>
<b>6 Machine/tool head DIA UNI-RG 80</b>	for RG 80, RGP 80, for paint, adhesive on wooden flooring., tool head with Uni diamond disc, Diameter 80 mm, in self-service display pack	-	<b>769169</b>
<b>Diamond disc DIA UNI-D80</b>	replacement disc for tool head DIA UNI-RG 80, Diameter 80 mm, in self-service display pack	-	<b>769170</b>
<b>7 Machine/tool head HW COARSE-RG 80</b>	for RG 80, RGP 80, for elastic coatings, adhesive on soft plaster, plaster and limestone on beams, thick and old layers of paint and roughening GRP, tool head with Coarse tungsten-carbide disc, Diameter 80 mm, in self-service display pack	-	<b>769056</b>
<b>Tungsten Carbide disc HW COARSE-D80</b>	replacement disc for tool head HW COARSE-RG 80, Diameter 80 mm, in self-service display pack	-	<b>769058</b>
<b>8 Machine/tool head HW FINE-RG 80</b>	for RG 80, RGP 80, for elastic coatings, adhesive on soft plaster, plaster and limestone on beams, thick and old layers of paint and roughening GRP, tool head with Fine tungsten-carbide disc, Diameter 80 mm, in self-service display pack	-	<b>769057</b>
<b>Tungsten Carbide disc HW FINE-D80</b>	replacement disc for tool head HW FINE-RG 80, Diameter 80 mm, in self-service display pack	-	<b>769059</b>



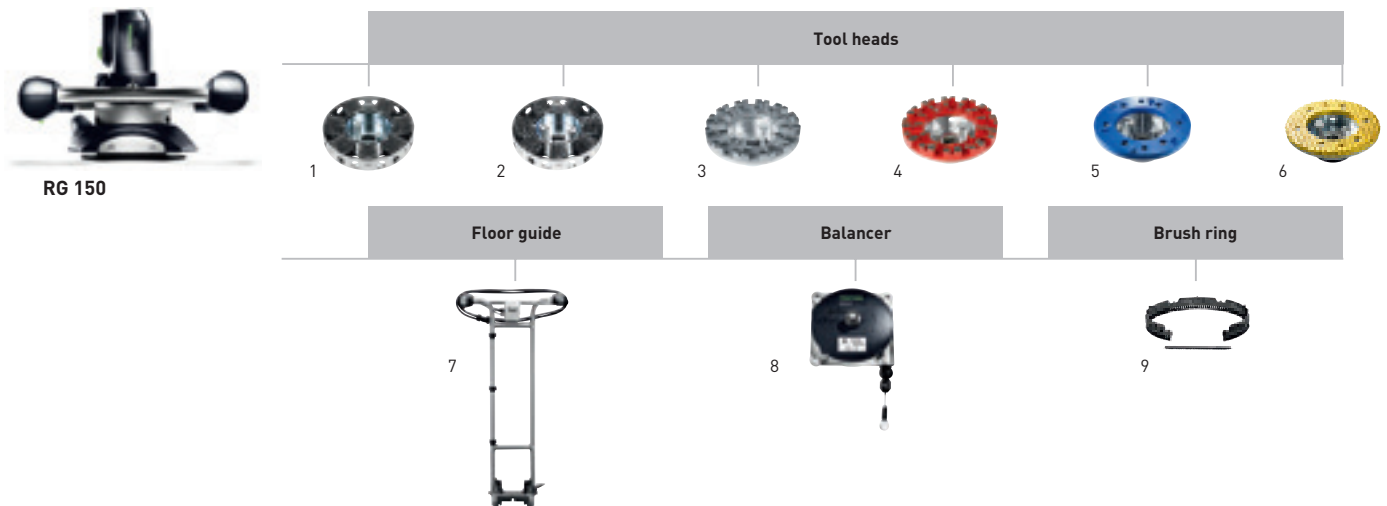

### Accessories for renovation miller RG 150 E

Denomination	Explanation	RRP in £*	Order no.
<b>1 Machine/tool head SZ-RG 150</b>	for RG 150, RGP 150, for hard plaster, adhesive residues and synthetic resin plaster, Diameter 150 mm, in self-service display pack	-	<b>768020</b>
<b>Cutter wheel HW-SZ 35</b>	35 carbide milling heads with "pointed teeth", replacement heads for SZ-RG 150, complete set with running sleeves, in self-service display pack	-	<b>769050</b>
<b>2 Machine/tool head FZ-RG 150</b>	for RG 150, RGP 150, for soft plaster, fresh concrete, adhesive residues and protective coatings, tool head with 35 carbide milling heads with "flat teeth", Diameter 150 mm, in self-service display pack	-	<b>769105</b>
<b>Cutter wheel HW-FZ 35</b>	35 "flat carbide-tipped milling heads", replacement heads for FZ-RG 150, complete set with running sleeves, in self-service display pack	-	<b>769051</b>
<b>3 Machine/tool head DIA HARD-RG 150</b>	for RG 150, RGP 150, for old solid concrete, removal of epoxy resin from solid surfaces or coatings/paints from concrete, tool head with hard diamond segments, Diameter 150 mm, in self-service display pack	-	<b>768021</b>
<b>Diamond disc DIA HARD-D150</b>	replacement disc for tool head DIA HARD-D150, Diameter 150 mm, in self-service display pack	-	<b>769069</b>
<b>4 Machine/tool head DIA ABRASIVE-RG 150</b>	for RG 150, RGP 150, for sand-based materials, screed, fresh concrete, adhesive on screed, sand-lime brick and cellular concrete, tool head with abrasive diamond segments, Diameter 150 mm, in self-service display pack	-	<b>768022</b>
<b>Diamond disc DIA ABRASIVE-D150</b>	replacement disc for tool head DIA ABRASIVE-D150, Diameter 150 mm, in self-service display pack	-	<b>769070</b>
<b>5 Machine/tool head DIA THERMO-RG 150</b>	for RG 150, RGP 150, For thermoelastic materials on concrete, screed, etc., tool head with THERMO diamond disc, Diameter 150 mm, in self-service display pack	-	<b>769083</b>
<b>Diamond disc DIA THERMO-D150</b>	replacement disc for tool head DIA THERMO-D150, Diameter 150 mm, in self-service display pack	-	<b>769085</b>
<b>6 Machine/tool head DIA UNI-RG 150</b>	for RG 150, RGP 150, for paint, adhesive on wooden flooring., tool head with Uni diamond disc, Diameter 150 mm, in self-service display pack	-	<b>769120</b>
<b>Diamond disc DIA UNI-D150</b>	replacement disc for tool head DIA UNI-D150, Diameter 150 mm, in self-service display pack	-	<b>769122</b>
<b>7 Floor guide BG-RG 150</b>	for RG 150, RGP 150, for easy guidance of RENOFIX RG 150 E over large areas, in a carton	-	<b>769109</b>
<b>8 Balancer BR-RG 150</b>	for RG 150 E-Plus for reliable and easy guidance along the wall	-	<b>769121</b>
<b>9 Brush ring BC-RG 150</b>	for RG 150, RGP 150, replaceable spare brush rim, in self-service display pack	-	<b>769123</b>

# Renovation, refurbishment and drywalling

## System accessories

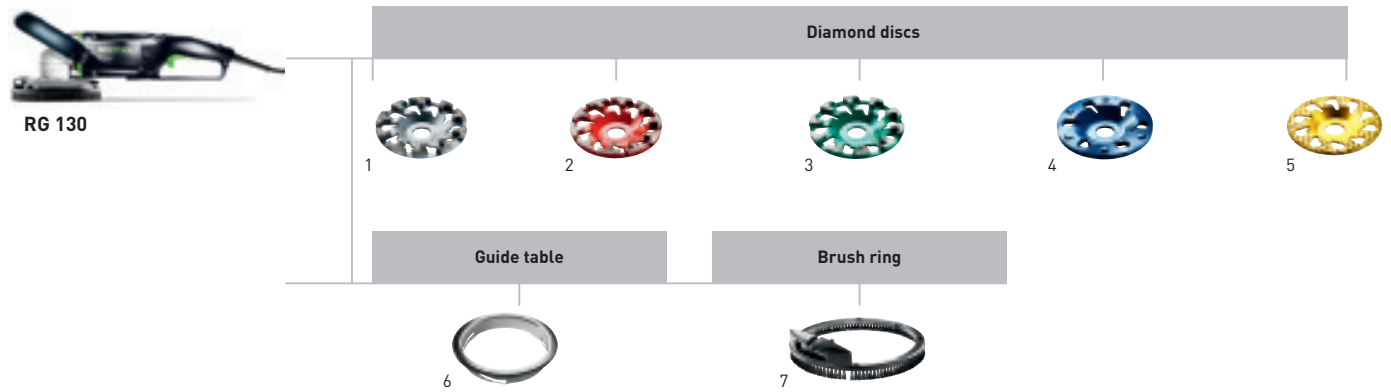

### Accessories for diamond grinder RENOFIX RG 130

Denomination	Explanation	RRP in £*	Order no.
<b>1 Diamond disc DIA HARD-D130 PREMIUM</b>	for RG 130, AG 125, RGP 130, AGP 125, for old solid concrete, removal of epoxy resin from solid surfaces or coatings/paints from concrete, Diameter 130 mm, Inside dia. 25/22,2 mm, in self-service display pack	- -	<b>768017</b>
<b>Diamond disc DIA HARD-RGP130-ST</b>	for RG 130, AG 125, RGP 130, AGP 125, for old solid concrete, removal of epoxy resin from solid surfaces or coatings/paints from concrete, Diameter 130 mm, Inside dia. 25/22,2 mm, in a carton	78,20 93,84	<b>499972</b>
<b>2 Diamond disc DIA ABRASIVE-D130 PREMIUM</b>	for RG 130, AG 125, RGP 130, AGP 125, for sand-based materials, screed, fresh concrete, adhesive on screed, sand-lime brick and cellular concrete, Diameter 130 mm, Inside dia. 25/22,2 mm, in self-service display pack	- -	<b>768018</b>
<b>Diamond disc DIA ABRASIVE-RGP130-ST</b>	for RG 130, AG 125, RGP 130, AGP 125, for sand-based materials, screed, fresh concrete, adhesive on screed, sand-lime brick and cellular concrete, Diameter 130 mm, Inside dia. 25/22,2 mm, in a carton	78,20 93,84	<b>499973</b>
<b>3 Diamond disc DIA STONE-D130 PREMIUM</b>	for RG 130, AG 125, RGP 130, AGP 125, for extremely hard materials and hard concrete (harder than B 35), Diameter 130 mm, Inside dia. 25/22,2 mm, in self-service display pack	- -	<b>769166</b>
<b>4 Diamond disc DIA THERMO-D130 PREMIUM</b>	for RG 130, AG 125, RGP 130, AGP 125, For removing thermoelastic materials, Diameter 130 mm, Inside dia. 25/22,2 mm, in self-service display pack	- -	<b>768023</b>
<b>5 Diamond disc DIA UNI-D130 PREMIUM</b>	for RG 130, AG 125, RGP 130, AGP 125, For paints on all materials, Diameter 130 mm, Inside dia. 25/22,2 mm, in self-service display pack	- -	<b>769167</b>
<b>6 Guide table GT-RG 130</b>	for RG 130, RGP 130, Enables the material removal capacity rate to be adjusted and thus the removal in defined layers, in self-service display pack	- -	<b>769080</b>
<b>7 Brush ring BC-RG 130</b>	for RG 130, RGP 130, replaceable spare brush rim, in self-service display pack	- -	<b>769110</b>

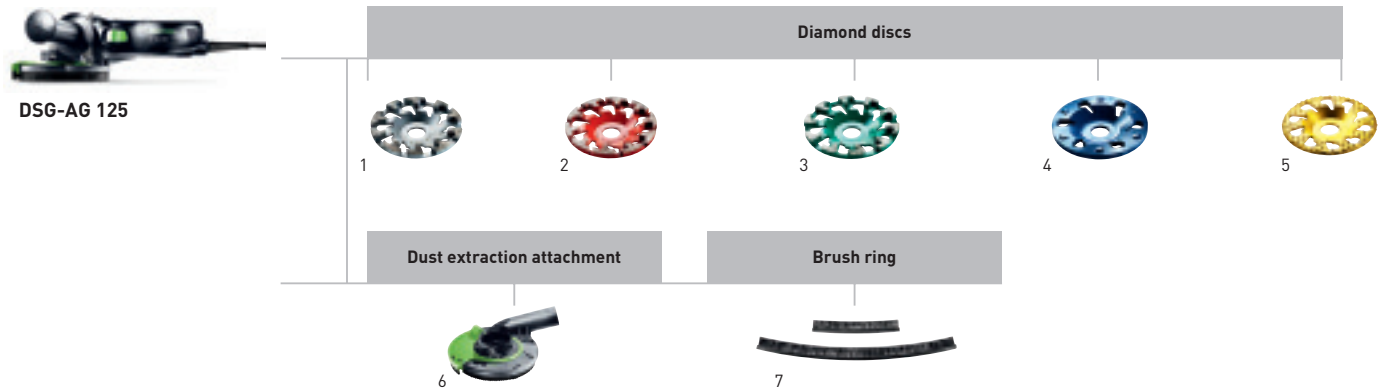

### Accessories for Diamant grinding system DSG-AG 125

Denomination	Explanation	RRP in £*	Order no.
<b>1 Diamond disc DIA HARD-D130 PREMIUM</b>	for RG 130, AG 125, RGP 130, AGP 125, for old solid concrete, removal of epoxy resin from solid surfaces or coatings/paints from concrete, Diameter 130 mm, Inside dia. 25/22,2 mm, in self-service display pack	-	<b>768017</b>
<b>2 Diamond disc DIA ABRASIVE-D130 PREMIUM</b>	for RG 130, AG 125, RGP 130, AGP 125, for sand-based materials, screed, fresh concrete, adhesive on screed, sand-lime brick and cellular concrete, Diameter 130 mm, Inside dia. 25/22,2 mm, in self-service display pack	-	<b>768018</b>
<b>3 Diamond disc DIA STONE-D130 PREMIUM</b>	for RG 130, AG 125, RGP 130, AGP 125, for extremely hard materials and hard concrete (harder than B 35), Diameter 130 mm, Inside dia. 25/22,2 mm, in self-service display pack	-	<b>769166</b>
<b>4 Diamond disc DIA THERMO-D130 PREMIUM</b>	for RG 130, AG 125, RGP 130, AGP 125, For removing thermoelastic materials, Diameter 130 mm, Inside dia. 25/22,2 mm, in self-service display pack	-	<b>768023</b>
<b>5 Diamond disc DIA UNI-D130 PREMIUM</b>	for RG 130, AG 125, RGP 130, AGP 125, For paints on all materials, Diameter 130 mm, Inside dia. 25/22,2 mm, in self-service display pack	-	<b>769167</b>
<b>6 Dust extraction attachment DCG-AG 125</b>	for AG 125, AGP 125-12/14, Clamping flange, disc Ø 125/130 mm, weight 0,4 kg, connection Ø d/e 36/27 mm, in self-service display pack	-	<b>769076</b>
<b>7 Brush ring BC-DCG AG 125</b>	for DCG-AGP 125, in self-service display pack	-	<b>769081</b>

# Renovation, refurbishment and drywalling

## System accessories



### Accessories for long-reach sander PLANEX LHS 225

Denomination	Explanation	RRP in £*	Order no.
<b>1 Sanding pad ST-STF-D215/8-LHS 225-HT</b>	for universal application on flat surfaces, high temperature durability burr, for heavy-duty applications, Diameter 215 mm, in self-service display pack	77,40 92,88	<b>495168</b>
<b>Sanding pad ST-STF-D215/8-IP-LHS 225</b>	for all types of applications, particularly suited for curved surfaces, incl. 2 interface pads, Diameter 215 mm, in self-service display pack	86,40 103,68	<b>496106</b>
<b>2 Interface pad IP-STF-D215/8/2x</b>	for use with sanding pad 496106, as damping element between sanding disc and sanding pad, Height 5 mm, Diameter 215 mm, qty. in pack 2 piece(s), in self-service display pack	23,45 28,14	<b>496140</b>
<b>3 Brush segment BS-LHS 225</b>	for long-reach sander PLANEX, detachable part of the brush strip of the PLANEX LHS 225 EQ sanding head, in self-service display pack	20,70 24,84	<b>495166</b>
<b>Brush strip BE-LHS 225</b>	for long-reach sander PLANEX, as a replacement for used brush strip, in self-service display pack	29,80 35,76	<b>495167</b>
<b>4 Abrasives</b>	from page 116		
<b>5 SYSTAINER T-LOC SYS-STF D225</b>	with insert for abrasive, dia. 225 mm, number of compartments 3, systainer size SYS 4 T-LOC	56,10 67,32	<b>497691</b>
<b>6 Guide extension VL-LHS 225</b>	for long-reach sander PLANEX, quick guide extension of the PLANEX for high ceilings, Length 500 mm, in self-service display pack	153,30 183,96	<b>495169</b>
<b>7 Carrying harness TG-LHS 225</b>	for long-reach sander PLANEX, working aid for sanding ceilings, additional side-mounted hand grip, in a SYSTAINER MAXI-SYS	192,90 231,48	<b>496911</b>
<b>Additional hand grip ZG-LHS 225</b>	for PLANEX and carrying harness, in a carton	38,00 45,60	<b>496916</b>
<b>8 SYSTAINER SYS-LHS 225</b>	for LHS 225, systainer size SYS MAXI	77,30 92,76	<b>495193</b>
<b>9 Tool holder WHR-CT 36-LHS 225</b>	for CT 36 PLANEX, with practical carrier handle, for storing PLANEX, in a carton	81,35 97,62	<b>495964</b>
<b>10 CT AC mobile dust extractor</b>	See "Extraction" chapter, CT AC series, page 275		
<b>11 plug-it-cable H05 RN-F/4</b>	rubber insulated cable 240V plug it, Length 4 m, in self-service display pack	19,60 23,52	<b>490650</b>
<b>plug-it-cable H05 RN-F/4 EU PLANEX</b>	for long-reach sander PLANEX, particularly suitable for use with the PLANEX LHS 225 thanks to extended cable bushing, for example for sanding work in dry construction, rubber insulated cable 240V plug it, Length 4 m, in self-service display pack	16,95 20,34	<b>499819</b>

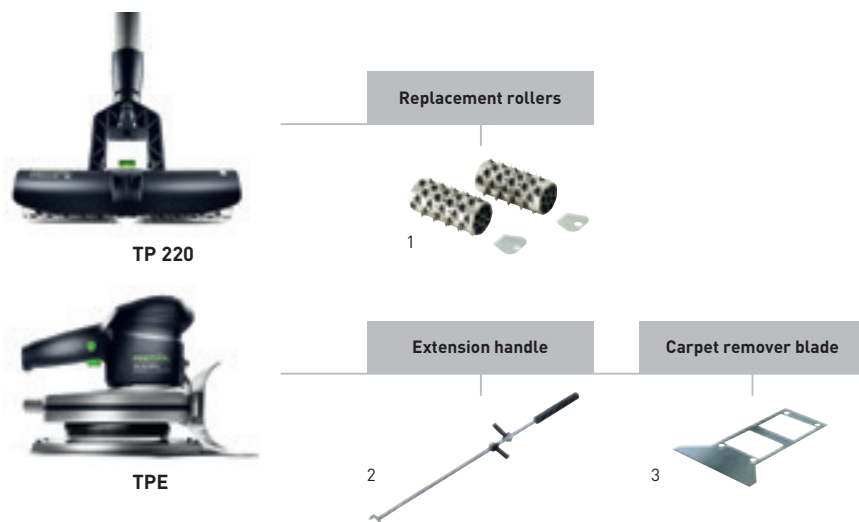

### Accessories for FAKIR TP 220 wallpaper perforator and TPE carpet remover

Denomination	Explanation	RRP in £*	Order no.
1 Replacement roller EW-TP 220	for TP 220, 2 rollers, in self-service display pack	32,85 39,42	496111
2 Extension-handle SG-TPE/RS 1	in two sections, allows use of TPE in standing position, with 2 additional hand grips and shoulder cushion, Length 1700 mm, in a carton	111,85 134,22	486375
3 Carpet remover-blade TM 195	for TPE-RS 100, blade width 195 mm, in a carton	30,80 36,96	486374



## Timber construction

**Overview of products and applications** 334

**Sword saws** SSU 200, IS 330 335

**Carpentry portable circular saw** HK 132 337

**Hand-held planer** PL 205, PL 245 338

**Chain mortiser** CM 150 339

**Accessories and consumable materials** 340

The Festool system

# Timber construction

## Overview of products and applications

Consistently further developed. The Festool electric power tools for wooden structures represent powerful, persistent and precise work in joinery and for renovation/masonry work in wooden structures. Whether it is cutting pressure-resistant insulating materials or planing wide beams.

Page 335 — 336 — 337 — 338 — 339

SSU 200

IS 330

HK 132

PL 205

PL 245

CM 150



### Applications

Sword saws

Carpentry portable circular saw

Hand-held planer

Chain mortiser

#### Cutting with sword saws

- Cutting soft and hard wood
- Cutting wood fibre insulating boards
- Cutting PUR insulating materials
- Cutting polystyrene



#### Sawing with carpentry circular saws

- Cross and rip cuts in wood
- Cutting insulating material (wood fibre, PUR)
- Routing notches and flat spots
- Cutting sandwich panels



#### Planing with beam planer

- Planing up to 205 mm
- Planing up to 245 mm



#### Routing with chain mortiser

- Making mortises up to 150 mm



● Extremely appropriate ○ Appropriate

#### Technical data

	SSU 200	IS 330	HK 132	PL 205	PL 245	CM 150
Power consumption (W)	1600	1600	2300	2000	2300	2000
Cutting depth 0°, 90°/45°/60° (mm)	200/140/100	330/230/165	50-132/85/50	-	-	-
Mitre cuts (°)	0-60	0-60	0-60	-	-	-
Idle engine speed (rpm)	4600	4600	2200	13500	13000	-
Cutting speed (idle speed) (m/s)	10,6	12	-	-	-	-
Sword position (°)	0-10	0-10	-	-	-	-
Max. planing width (mm)	-	-	-	205	245	-
Adjustable planing depth (mm)	-	-	-	0-3	0-3	-
Mortising depth (mm)	-	-	-	-	-	100/150
Speed of chain sprocket (rpm)	-	-	-	-	-	4250
Weight (kg)	6,5	7	18	13	15,7	8,5





SSU 200



### Small handy machine with 200 mm cutting depth

- ▶ 200 mm cutting depth and 6.5 kg weight
- ▶ Integrated guide slot in the aluminium die cast base plate for accurate cuts using the guide rail
- ▶ Wide application range for mitre cuts up to 60°
- ▶ Chain changed and tensioned without using tools

#### Technical data

Power consumption [W]	1600
Cutting depth 0°/90°/45°/60° mm [mm]	200/140/100
Mitre cutting [°]	0-60
Idle engine speed [min <sup>-1</sup> ]	4600
Chain speed [m/s]	10,6
Blade position [°]	0-10
weight [kg]	6,5



■ = with MMC electronics

#### Items Included

universal saw chain SC 3/8" 91 U-39E, chain oil 250 ml,  
7.5 m power cord, in a SYSTAINER SYS 5 T-LOC

	RRP in £*	Order no.
<b>SSU 200 EB-Plus GB 240V</b>	789,00 946,80	<b>769211</b>
<b>SSU 200 EB-Plus-FS GB</b>	819,00	<b>769212</b>
guide rail FS 800/2	982,80	

\* Recommended retail price of manufacturer. Dealer prices may vary.  
Excl. VAT.  
Incl. VAT.

**System accessories**  
from page 342



**Mobile dust extractors**  
from page 272



### Precise cut.

Whether it is wood or insulating material, the UNIVERS SSU 220 sword saw cuts all common materials in wooden structures up to 200 mm thick.

## Timber construction

### Sword saw IS 330



# IS 330



### The specialist for cutting insulating materials.

The sword saw IS 330 combines the advantages of a chain saw and a portable circular saw with a guide rail in a unique mobile system. Cutting pressure-resistant insulating materials such as wood fibre and PU boards is this easy, quick and accurate thanks to the guide rail.

### The size with 330 mm cutting depth.

- ▶ Ideal for construction sites: cutting depth of 330 mm for cutting thick insulating materials to size and 7.0 kg in weight
- ▶ 60° mitre cutting angle with a cutting depth of 165 mm
- ▶ Straight and splinter-free cuts thanks to guide rails
- ▶ Rotary dust-extraction attachment for connecting an extractor

#### Technical data

Power consumption (W)	1600
Cutting depth 0°/90°/45°/60° mm (mm)	330/230/165
Idle engine speed (min <sup>-1</sup> )	4600
Mitre cutting (°)	0-60
Chain speed (m/s)	12
Blade position (°)	0-10
weight (kg)	7,0



= with MMC electronics

This product is not available in Great Britain.

System accessories  
from page 342



Mobile dust extractors  
from page 272





HK 132



**3-in-1. Saw, notch cutter, flattening planer.**

- ▶ Trouble-free retraction control of the movable guard, particularly of benefit for mitre cutting
- ▶ Accurate, fixed adjustment for mitre-cutting up to 60°
- ▶ Multi-purpose electronics: soft starting, reduction of no-load speed, constant speed electronics, prevention of thermal destruction and protection against overload
- ▶ Optimum amount of force/control from the operator via rear pistol grip which is in the cutting plane

Technical data	HK 132 E	HK 132/RS-HK	HK 132/NS-HK
Power consumption [W]	2300	2300	2300
Cutting depth 0°/90° [mm]	50-132	50-132	50-132
Cutting depth at 45 degrees/60 degrees [mm]	85/50	85/50	85/50
Max. routing width [mm]		80	
Max. planing width [mm]			50
Max. planing depth [mm]			0-80
Max. milling depth [mm]		0-38	
Idle engine speed [min <sup>-1</sup> ]	2200	2200	2200
Mitre cutting [°]	0-60	0-60	0-60
weight [kg]	18	18	18



■ = with electronics

This product is not available in Great Britain.

**3-in-1. Saw, notch cutter, flattening planer.**

On the one hand, a portable circular saw with 132 mm cutting depth. Replace the saw blade for a notch cutter and the HK 132 E becomes a reliable milling machine. Also the retrofit to the planer is easy.

System accessories  
from page 343

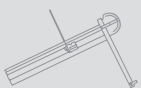

Saw blades  
from page 42



## Timber construction

### Beam planer PL 205 and PL 245



# PL 205 / PL 245



### Hand-held planer with turbo chip ejection.

In modern wooden structures, more and more visible wooden surfaces are on show. The beam planers PL 205 and PL 245 offer the optimal prerequisites for clean, smooth surfaces with an excellent planing result.

### Hand-held planer with turbo chip ejection.

- ▶ Safe guidance due to ideal positioning of the handles and lengthy planer base
- ▶ Superior chip discharge efficiency with the "turbo" mechanism, providing clear visibility to the work piece
- ▶ Ideal method of planing depth adjustment by means of the front handle situated adjuster
- ▶ Safe, accurate chamfering of material made easy by the V-groove in the planer base

#### Technical data

	PL 205 E	PL 245 E
Power consumption (W)	2000	2300
Idle engine speed (min <sup>-1</sup> )	13500	13000
Max. planing width (mm)	205	245
Planing depth range (mm)	0-3	0-3
weight (kg)	13,0	15,7



= with electronics

This product is not available in Great Britain.

System accessories  
from page 344

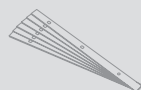



CM 150



### Chain mortiser: Professional mortising and slotting carpentry machine

- ▶ Accurate guidance via the precision adjustable parallel fence, with large supporting interface surface
- ▶ Sustainable performance from the heavy-duty motor
- ▶ Easy operation due to the ergonomic design and comfortable weight

#### Technical data

Power consumption (W)	2000
Mortising depth (mm)	100/150
Lateral fence adjustment (mm)	0-150
Drive sprocket speed (min <sup>-1</sup> )	4250
weight (kg)	8,5

This product is not available in Great Britain.

### The multitalented tool for mortising.

With its compact and lightweight design, the chain mortiser CM 150 is particularly easy to handle and thus ideally suited for subsequent roof constructions, the renovation and refurbishment of old buildings or aligning the roof truss, if adjustments or reworking are required on the construction site. With the stable and large side stop, the chain mortiser can be reliably guided, also when working at the installed beam and overhead.

System accessories  
from page 345

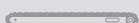

### **The Festool system.**

Because it's simply better when everything fits together:

The Festool electric power tools for wooden structures represent powerful, persistent and precise work in joinery and for renovation and refurbishment work. The suitable and comprehensive system accessories, from the notch cutter for the carpentry portable circular saws to the mortising chain sets for the chain mortisers, help complete the work efficiently and safely.



## Timber construction

Accessories and consumable materials

### Sword saws

System accessories 342

### Carpentry circular saws

System accessories 343

### Hand-held planer

System accessories 344

### Chain mortiser

System accessories 345



## Timber construction

### System accessories



SSU 200



IS 330

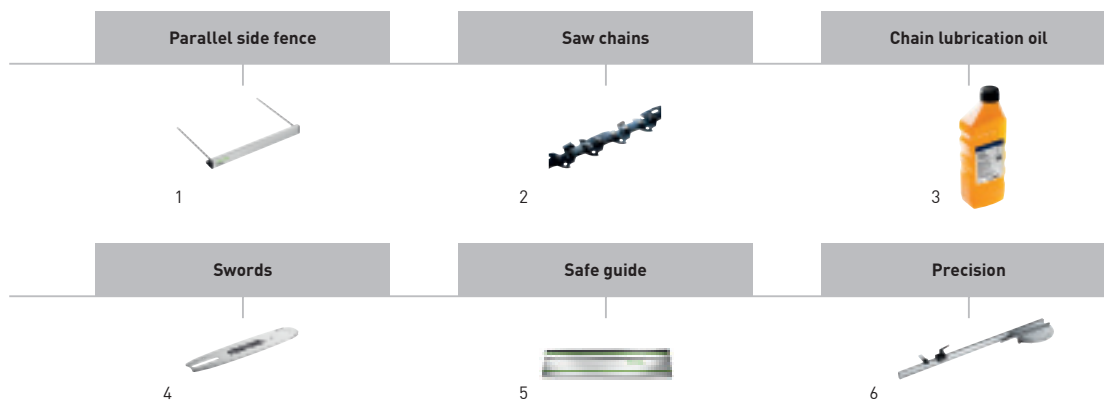

#### Accessories for sword saws SSU 200, IS 330

Denomination	Explanation	RRP in £*	Order no.
<b>1 Parallel side fence PA-SSU 200</b>	for SSU 200, IS 330, SSP 200, ISP 330, parallel guide, guided on both sides, in a carton	32,35 38,82	<b>769098</b>
<b>Parallel side fence PA-A SSU 200</b>	for SSU 200, IS 330, SSP 200, ISP 330, bilateral offset parallel stop, in a carton	56,40 67,68	<b>769099</b>
<b>2 Chainsaw chain SC 3/8"-91 U-39E</b>	for SSU 200, SSP 200, saw chain Uni, chain pitch 3/8", for rip and cross cuts, in self-service display pack	24,25 29,10	<b>769101</b>
<b>Chainsaw chain SC 3/8"-91 L-39E</b>	for SSU 200, SSP 200, saw chain, longitudinal cuts, chain pitch 3/8", for rip cuts, in self-service display pack	30,35 36,42	<b>769103</b>
<b>Chainsaw chain SC 3/8"-91 F-39E</b>	for SSU 200, SSP 200, saw chain fine, chain pitch 3/8", for fine and cross cuts, in self-service display pack	30,35 36,42	<b>769102</b>
<b>Chainsaw chain SC 3/8"-90 I-39E</b>	for SSU 200, SSP 200, saw chain ISO, chain pitch 3/8", for flexible to pressure-resistant insulating materials, in self-service display pack	49,35 59,22	<b>769100</b>
<b>Chainsaw chain SC 3/8"-90 I-57E</b>	for IS 330, ISP 330, saw chain ISO, chain pitch 3/8", for flexible to pressure-resistant insulating materials, in self-service display pack	- -	<b>769088</b>
<b>Chainsaw chain SC 3/8"-91 IH-57E</b>	for IS 330, ISP 330, saw chain ISO Hard, chain pitch 3/8", for extremely pressure-resistant insulating materials, in self-service display pack	- -	<b>769090</b>
<b>3 Chain lubrication oil CO 1 L</b>	for SSU 200, IS 330, SSP 200, ISP 330, CCP 380, volume 1 litre, In plastic bottle	7,70 9,24	<b>769038</b>
<b>4 Blade GB 10"-SSU 200</b>	for SSU 200, SSP 200, in self-service display pack	45,35 54,42	<b>769066</b>
<b>Blade GB 13"-IS 330</b>	for IS 330, ISP 330, in self-service display pack	- -	<b>769089</b>
<b>5 Guide rail</b>	see chapter Workplace organisation on page 352		
<b>6 Angle stop</b>	see chapter Workplace organisation on page 370		





HK 132

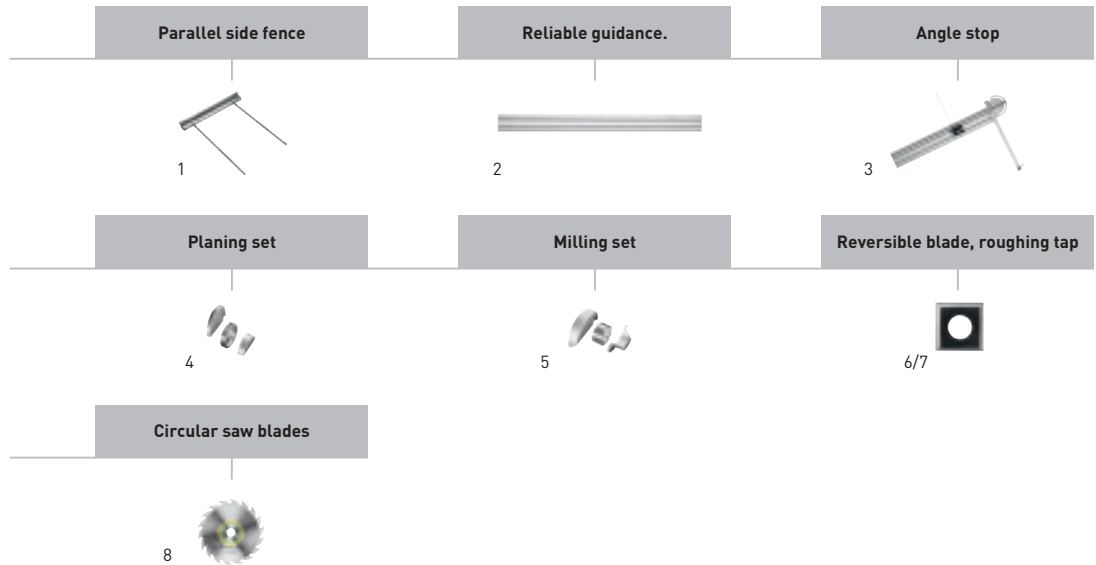

### Accessories for carpentry portable circular saws HK 132

Denomination	Explanation	RRP in £*	Order no.
<b>1 Parallel side fence PG-HK 132</b>	for HK 132, CSP 132, for using HK 132 E/W with guide rails, type GC 2000/3000, in a carton	-	<b>769538</b>
<b>2 Guide rail GC 2000</b>	for HK 132, CSP 85/60, CSP 132, CSP 165, CCP 380, NRP 90, 2000 mm long, in wooden box	-	<b>769669</b>
<b>Guide rail GC 3000</b>	for HK 132, CSP 85/60, CSP 132, CSP 165, CCP 380, NRP 90, 3000 mm long, in wooden box	-	<b>769670</b>
<b>3 Angle stop GC 1000-WA</b>	for HK 132, CSP 85/60, CSP 132, CSP 165, CCP 380, NRP 90, angle indicator with 1000 mm guide rail and gauge marker, Angle stop, for variable angle adjustment up to 90° on both sides, With gauge marker for adjusting each mitre cut to scribe mark, in a carton	-	<b>769671</b>
<b>4 Planing set NS-HK 250x50</b>	for HK 132, CSP 132, carbide pre-cutter 14 x 14 x 2.0 mm, carbide reversible blade 50 x 12 x 1.5 mm, 1 fixed guard, 1 movable guard with remote control, clamping rails, planing head Ø 250 mm, planing width 50 mm, planing depth 0-80 mm, drilling 30 mm, weight 6,8 kg, in a carton	-	<b>769539</b>
<b>5 Milling set RS-HK 160x80</b>	for HK 132, CSP 132, milling head Ø 160 x 80 mm, carbide reversible blade 80 x 13 x 2.2 mm, carbide pre-cutter 14 x 14 x 2.0 mm, 1 fixed guard, 1 movable guard with remote control, clamping rails, planing head Ø 160 mm, planing width 80 mm, planing depth 0-38 mm, drilling 30 mm, weight 7,1 kg, in a carton	-	<b>769540</b>
<b>6 Reversible cutter blade CT-HK HW 50x12x1,5/3</b>	for planer head NS-HK 250 x 50 and flattening head Ø 260 x 50, NS-CSP 250 x 50, HK 132, NRP 90, qty. in pack 3 piece(s), dimensions 50 x 12 x 1,5 mm, in self-service display pack	-	<b>769544</b>
<b>Reversible cutter blade CT-HK HW 80x13x2,2/3</b>	for notch cutter head RS-HK 160 x 80, RS-CSP 160 x 80, HK 132, CSP 132 E, qty. in pack 3 piece(s), dimensions 80 x 13 x 2,2 mm, in self-service display pack	-	<b>769543</b>
<b>7 Pre-cutter CT-HK HW 14x14x2/6</b>	for planer and notch cutter head, for HK 132, CSP 132, NRP 90, qty. in pack 6 piece(s), dimensions 14 x 14 x 2 mm, in self-service display pack	-	<b>769542</b>
<b>8 Circular saw blades</b>	from page 42	-	

## Timber construction

### System accessories



PL 205/245

Cutter block with two tri-metal reversible blades

1



#### Accessories for beam planer PL 205, PL 245

Denomination	Explanation	RRP in £*	Order no.
1 Reversible cutter blade RN-PL 19x1x205 Tri. 6x	for PL 205 E, PLP 205 E, Tri-metal, qty. in pack 6 piece(s), dimensions 19 x 1 x 205 mm	-	769545
Reversible cutter blade RN-PL 19x1x245 Tri. 6x	for PL 245 E, PLP 245 E, Tri-metal, qty. in pack 6 piece(s), dimensions 19 x 1 x 245 mm	-	769546



CM 150



### Accessories for chain mortiser CM 150

Denomination	Explanation	RRP in £*	Order no.
<b>1 Guide frame GM 145</b>	for chain cutters 100-150 mm in length, for mortising, pneumatic springs, depth stop, side stop, mort. depth with the chain cutter 100 mm: 95 mm, mort. depth with the chain cutter 125: 120 mm, mort. depth with the chain cutter 150: 145 mm, lateral fence adjustment range 5-150 mm, weight 4,8 kg, in a carton	-	<b>769541</b>
<b>2 Chain cutter MF-CM 28x35x100 A</b>	for CM 150, CMP 150, slot, -chain width 28 mm, slot length 35 mm, slot depth 100 mm, in a carton	-	<b>769547</b>
<b>Chain cutter MF-CM 28x40x100 A</b>	for CM 150, CMP 150, slot, -chain width 28 mm, slot length 40 mm, slot depth 100 mm, in a carton	-	<b>769548</b>
<b>Cutting chain MC-CM 28x35/40x100 A</b>	for chain cutter MF-CM 28 x 35/40 x 100 A, MF-CMP 28 x 35/40 x 100 A, Individual milling machine chain for fittings, slot, -chain width 28 mm, slot length 35/40 mm, slot depth 100 mm, in a carton	-	<b>769551</b>
<b>Chain cutter MF-CM 28x40x150 A</b>	for CM 150, CMP 150, slot, -chain width 28 mm, slot length 40 mm, slot depth 150 mm, in a carton	-	<b>769549</b>
<b>Cutting chain MC-CM 28x40x150 A</b>	for chain cutter MF-CM 28 x 40 x 150 A, MF-CMP 28 x 40 x 150 A, Individual milling machine chain for fittings, slot, -chain width 28 mm, slot length 40 mm, slot depth 150 mm, in a carton	-	<b>769552</b>
<b>Chain cutter MF-CM 30x30x125 B</b>	for CM 150, CMP 150, slot, -chain width 30 mm, slot length 30 mm, slot depth 125 mm, in a carton	-	<b>769550</b>
<b>Cutting chain MC-CM 30x30x125 B</b>	for chain cutter MF-CM 30 x 30 x 125 B, MF-CMP 30 x 30 x 125 B, Individual milling machine chain for fittings, slot, -chain width 30 mm, slot length 30 mm, slot depth 125 mm, in a carton	-	<b>769553</b>



## Workplace organisation

<b>Compact Module System</b> CMS	348
<b>Multifunction table</b> MFT 3	350
<b>Vacuum clamping system</b> VAC-SYS	351
<b>Guide systems</b> FS/2, GECKO	352
<b>Vacuum clamping nozzle</b> CT WINGS	355
<b>Boom arm</b> ASA	356
<b>Energy box</b> EAA	357
<b>Workcenter</b> WCR	358
<b>Multifunction stool</b> MFH 1000, UCR 1000	359
<b>Toolcenter</b> TC 3000/2	360
<b>Working light</b> SYSLITE KAL II	361
<b>Storage systems</b> SYSTAINER, SORTAINER, ToolBox	362
<b>Transportation systems</b> SYS-Port, SYS-Roll, SYS-Cart	363

<b>Accessories and consumable materials</b>	364
---	-----

The Festool system

## Workplace organisation

### The CMS Compact Module System

#### CMS Compact Module System. Open to change.

Five machines in one. Stationary or handheld. Covers 0.5 m<sup>2</sup>. Only possible with a system. The CMS Compact Module System consists of a basic unit and compatible modules that transform the unit into a stationary bench-mounted saw, jigsaw, bench-mounted router or belt sander.

#### Safe and convenient.

The machines can be switched on and off from the basic unit.

#### Mobile and stable.

At only 10.8 kg, the basic unit is extremely lightweight yet robust.

#### Adjustable height.

Foldaway legs on the basic unit allow you to work on the floor or standing up.

#### Easy to extend.

A comprehensive selection of accessories such as the sliding table, angle stop and extension table are available so the CMS can be adapted for a wide range of applications.

### CMS modules



**Circular saw TS 55 R**  
Page 16



**Module mounting CMS-TS 55 R**  
Page 19



**Module CMS-MOD-TS 55-R**  
Page 19



**Circular saw TS 75**  
Page 18



**Module mounting CMS-TS 75**  
Page 19



**Module CMS-MOD-TS 75**  
Page 19



**Router OF**  
Page 138



**Module mounting CMS-OF**  
Page 142



**Pendulum jigsaws PS**  
Page 12



**Module mounting CMS-PS**  
Page 15  
**ADT-PS 400 adapter table**  
Page 371



(PS 420/400)



All modules in the established Basis-Plus System can be combined with the basic unit of the CMS, except for the Basis 1 A module.

All CMS modules are compatible with the Basis Plus basic unit, except for the CMS-TS 75. The sliding table Basis SAS must be fitted in the Basis Plus before the CMS-TS 55 R can be used (order no. 493955).



**Basis module tower MT 1600**  
for space-saving storage of the CMS and Basis modules



**Module CMS-MOD BS 120**  
Page 76

# Workplace organisation

## The CMS Compact Module System

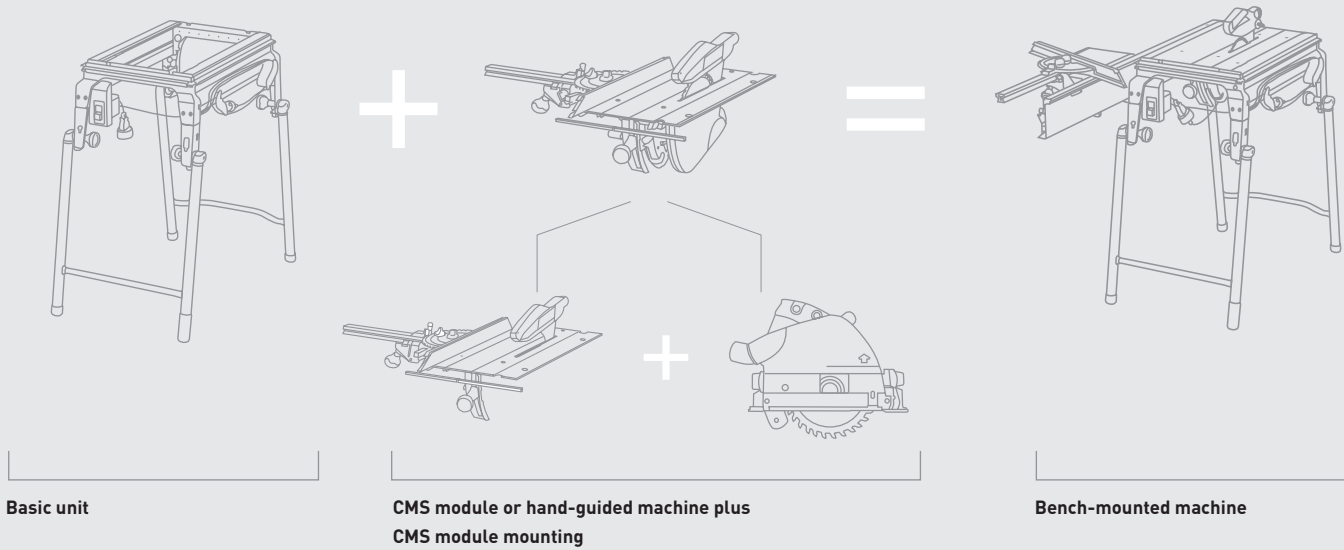

### Basic unit

### Bench-mounted machine

+

+

+

+

+



#### Technical data

Table height, legs unfolded	900 mm
Table height, legs folded away	316 mm
Table dimensions	585 x 400 mm
weight	10.8 kg

#### Items Included

Items Included	RRP in £*	Order no.
<b>Basic unit CMS-GE</b>	401,00	561261
Basic unit for fitting CMS modules, foldaway legs, main safety switch, cable holder/workpiece holder, cable and socket	481,20	

\* Recommended retail price of manufacturer. Dealer prices may vary.  
Excl. VAT.  
Incl. VAT.

=

=

=

=

=



**Bench saw CMS-TS 55 R Set**  
Page 19



**Bench saw with TS 75**



**Bench-mounted router TF 2200 Set**  
Page 143

**TF 1400 set**  
Page 143

**Bench-mounted router with OF 1010**



**Bench-mounted jigsaw with PS**



**Bench-mounted belt sander with BS 120**

## Workplace organisation

### Multifunction table MFT 3

# MFT 3



### Always the right accessories.

Everything is secured safely in place, from guide rails to combination bevells. The MFT/3 extension allows the insertion of all CMS modules, while the sliding table enables cross cuts with a maximum width of 830 mm.



### 1 table. 1000 possibilities.

- ▶ Maximum precision – with aluminium profile for retaining a guide rail and the angle stop
- ▶ Firm hold – specially developed clamping elements secure workpieces with maximum flexibility
- ▶ Avoid straining your back – the working height of 90 cm is comfortable even for taller users
- ▶ Ideal for mobile applications – the MFT 3 folds down easily

#### Technical data

Table dimensions (mm)	1157 x 773
Table height, legs folded away (mm)	180
Table height, legs unfolded (mm)	900
Maximum workpiece thickness (mm)	78
Max. workpiece width (mm)	700
Load capacity (kg)	120
weight (kg)	28

Items Included	RRP in £*	Order no.
table with perforated top and foldaway legs, in a carton		
<b>MFT/3</b>	533,00	<b>495315</b>
swivel unit, support unit, angle stop, adjustable stop, guide rail FS 1080/2, deflector FS-AW, additional clamp	639,60	
<b>MFT/3 Basic</b>	417,00	<b>500608</b>
	500,40	

\* Recommended retail price of manufacturer. Dealer prices may vary.  
Excl. VAT.  
Incl. VAT.

#### System accessories from page 367

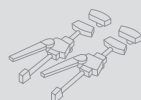

#### Watch the product video







# VAC SYS

### The future of clamping.

- ▶ Machine workpieces from all sides – rotate 360° and tilt 90°
- ▶ Suitable for delicate surfaces – the pads are made from soft, flexible plastic
- ▶ Powerful control – each clamping unit can secure workpieces up to 30 kg and 1 x 1 m
- ▶ For mobile use – pump and clamping units are stored in a SYSTAINER for easy transportation

#### Technical data

Power consumption at 50 Hz (W)	160-200
Power consumption at 60 Hz (W)	200-230
Pump capacity at 50 Hz (m³/h)	2,7
Pump capacity at 60 Hz (m³/h)	3,5
Minimum vacuum (mbar)	≥ 81% / ≥ 810
weight (kg)	8



Items Included	RRP in £*	Order no.
vacuum hose		
<b>VAC SYS Set SE1 GB 240V</b>	885,00	<b>712257</b>
vacuum pump VAC SYS VP, vacuum clamping unit VAC SYS SE1, vacuum pad VAC SYS VT D 215, foot valve	1.062,00	
<b>VAC SYS SE 2</b>	410,00	<b>580062</b>
vacuum pad VAC SYS VT 275 x 100 mm, connector, in a SYSTAINER SYS 4	492,00	



### Pads replaced without using tools.

There are four pad sizes for different workpieces to choose from and they can be replaced quickly with FastFix.

\* Recommended retail price of manufacturer. Dealer prices may vary.  
Excl. VAT.  
Incl. VAT.

System accessories  
from page 368



Watch the product video



## Workplace organisation

### Guide rail FS/2

The guide rail is available in 8 different lengths, from 800 mm to 5000 mm.

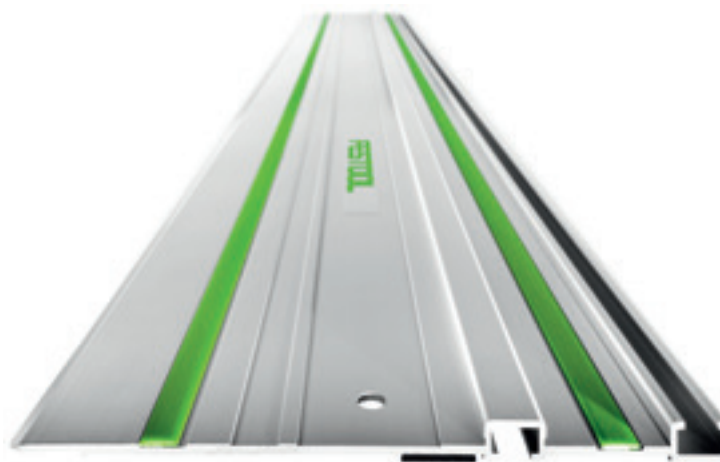

# FS/2



### Impeccable guidance.

- ▶ Zero-play guidance – you can adjust the guidance jaws on the circular saw to fit the guide rail without using tools
- ▶ Splinter-free cuts – the splinter guards positioned directly on the scribe line prevent the edges from splintering, even on angled cuts.
- ▶ Precision results – the router guide stop was designed for precision grooves
- ▶ Quick for diagonal cuts – with guide rail and combination bevel, angles are easy to transfer from the workpiece or wall

Items Included	RRP in £*	Order no.
in a carton		
<b>FS 800/2</b>	46,90 56,28	<b>491499</b>
<b>FS 1080/2</b>	59,55 71,46	<b>491504</b>
<b>FS 1400/2</b>	70,30 84,36	<b>491498</b>
<b>FS 1900/2</b>	120,60 144,72	<b>491503</b>
<b>FS 2400/2</b>	173,05 207,66	<b>491502</b>
<b>FS 2700/2</b>	201,40 241,68	<b>491937</b>
<b>FS 3000/2</b>	216,30 259,56	<b>491501</b>
<b>FS 5000/2</b>	356,25 427,50	<b>491500</b>
<b>FS 1400/2-LR 32</b>	86,10 103,32	<b>496939</b>
<b>FS 2424/2-LR 32</b>	210,05 252,06	<b>491622</b>

### Suitable for furniture construction.

A router and guide rail with rows of holes simplify the installation of shelves or fittings.

FS 800/2 = length 800 mm, FS 1080/2 = length 1080 mm, FS 1400/2 = length 1400 mm etc. FS 1400/2-LR 32 and FS 2424/2-LR 32 = guide rails with rows of holes 32 mm apart.

\* Recommended retail price of manufacturer. Dealer prices may vary.  
Excl. VAT.  
Incl. VAT.

### System accessories from page 370

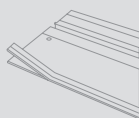



#### Precision in series

The workpiece width can be conveniently adjusted using the parallel stop with a scale and adjustable stop. Ideal for a small series of cuts identical in length.

#### The guide rail is synonymous with Festool.

After all, who else other than the inventor can look fondly back over 50 years of experience? In 1964 Festool made a breakthrough in precision and simplifying work with the guide rail. It included a host of useful details such as the slideway lining, splinter-guard for splinter-free cuts, groove for fastening and lever clamps as well as groove accessories for attaching combination bevels, kickback stops and dual suction pads. For perfect cuts and straight grooves.

#### A firm hold

The adhesive cushion strips keep the rail secure while simultaneously protecting the surface. Clamps, FS-Rapid quick-action clamp and GECKO DOSH are also available for a more secure grip.



#### Runs smoothly to the end

The deflector enables the extractor hose to glide smoothly during work.



#### Safe limit

The kickback stop serves as a limit stop or secures the plunge-cut saw against kickbacks when inserting in the tool.



## Workplace organisation

### GECKO dual suction pad



product  
design  
award

2006



# GECKO



### Designed for a system.

The GECKO can be mounted directly to a guide rail using the guide rail adapter.

### Secure connection for a long time.

- ▶ Ergonomic – the torsionally rigid handle makes it much easier to lift heavy loads
- ▶ Retains the position, preserves the material – special sliding rings mounted on both suction cups allow you to position the GECKO precisely and release it just as easily
- ▶ Secure hold – the green clamping levers provide quick and reliable suction. For a loading capacity of 50 kg
- ▶ Designed for a system – the GECKO can be mounted directly to a guide rail using the guide rail adapter

#### Technical data

Load capacity (kg)

50

Items Included	RRP in £*	Order no.
in self-service display pack		
<b>GECKO DOSH</b>	49,30	<b>492617</b>
	59,16	
<b>GECKO DOSH-Set</b>	65,00	<b>493507</b>
adapter DOSH-FSAD, dual suction pad GECKO DOSH	78,00	

\* Recommended retail price of manufacturer. Dealer prices may vary.  
Excl. VAT.  
Incl. VAT.

#### System accessories from page 370





## CT WINGS

### The third hand. Precisely when you need it.

- ▶ In many cases replaces the assistant when it comes to having a free hand for marking, clamping, gripping, etc.
- ▶ For effortless, precise and safe work
- ▶ Small, compact and always at hand
- ▶ Perfect in the system – in combination with a Festool mobile dust extractor and suction hose with 27 mm diameter

#### Technical data

Max. clamping height (mm)	50
Max. load (kg)	3
Dimensions (L x W x H) (mm)	130 x 80 x 50
weight (kg)	0,35

Items Included	RRP in £*	Order no.
in self-service display pack		
<b>CT-W</b>	28,45 34,14	<b>500312</b>



### Assembly aid through suction force.

The practical assembly aid for clamping and fixing workpieces on horizontal and vertical areas. Simply position CT WINGS at a 27 mm suction hose with machine sleeve, switch on the mobile dust extractor and then the workpiece is held in place with the suction power.

\* Recommended retail price of manufacturer. Dealer prices may vary.  
Excl. VAT.  
Incl. VAT.

**CT mobile dust extractors**  
from page 268



## Workplace organisation

### Boom arms ASA

ASA



### Workplace changes made easy.

Boom arms are primarily used in locations where workplaces need to be flexible or where a large operating radius is required. Power and dust extraction is supplied where it is needed, while avoiding tripping hazards. This saves you time moving equipment and creates more space in the workshop.



### For large working areas.

- ▶ Large usage range of up to 84 m<sup>2</sup>
- ▶ Maximum flexibility, extra safety, no dangerous obstacles
- ▶ For use with Festool CT/SRM mobile dust extractors
- ▶ Integrated compressed air and electrical lines for connection to EAA and CT

#### Technical data

	ASA 5000 CT/ SR-EU	ASA 6000 CT/ SR-EU
Connecting line length (m)	3	3
weight (kg)	92	105
Boom extension (m)	2 x 2,5	2 x 3,0
Cutting angle adjustment (°)	39-58	56-84



#### Items Included

double-jointed arm with wall bracket, cable duct, wall mounting components are not included, in a carton

	RRP in £*	Order no.
<b>ASA 5000 CT/SR-EU</b>	2.087,00 2.504,40	<b>583867</b>
<b>ASA 6000 CT/SR-EU</b>	2.181,00 2.617,20	<b>583868</b>

\* Recommended retail price of manufacturer. Dealer prices may vary.  
Excl. VAT.  
Incl. VAT.

#### System accessories from page 369

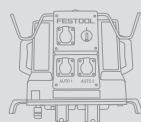

## Workplace organisation

EAA energy box CT/SR



### For greater ease of movement.

- ▶ Manual adjustment – the slide valve provides suction power wherever an electric and/or air tool is currently in operation
- ▶ Flexible – the EAA can be mounted on a ceiling, wall or boom arm
- ▶ Ready for immediate use – two electric or air tools can be hung directly on the housing of the EAA
- ▶ Better organisation – two hoses can be stored and kept clean in the hose holders on the rear of the EAA

Technical data	EAA EW CT/ SRM/M-EU	EAA EW/DW CT/ SRM/M-EU
Dimensions (L x W x H) (mm)	506 x 580 x 367	516 x 580 x 367
Pressure range (bar)	4-8	4-8
weight (kg)	10,2	13



This product is not available in Great Britain.



### Sophisticated design right down to the smallest detail.

The EAA with connectible, manually operated sliders for use with the CT mobile dust extractor saves the user annoying handles and paths and ensures optimal dust extraction. Electric power tools and compressed air tools are ready for use and ready to hand at all times.

System accessories  
from page 369



## Workplace organisation

WCR 1000 Workcenter



product  
design  
award

2011

# WCR 1000



## Customised configuration.

SYSTAINER sizes 1 to 4 or SORTAINERS can be integrated into the Workcenter.



## Mobility in the tightest of spaces.

- ▶ Compact and mobile – the WCR can be coupled with any Festool mobile dust extractor with integral SYS-Dock (except CTL MINI/MIDI)
- ▶ Flexible equipment – hooks for hanging two machines with extractor hoses, a universal holder, storage compartment and rotating storage tray for sundries
- ▶ Individual extension – additional storage trays, hooks or holders can be mounted on the perforated plate and profiled groove
- ▶ Work without straining your back – the height of the Workcenter, hooks and storage trays is easy to adjust

### Technical data

Length (mm)	1050
Width (mm)	362
Height adjustable (mm)	545-785
Size of square hole pattern (mm)	9,2 x 9,2
Inner hole distance of square hole pattern (mm)	38
weight (kg)	10,2

Items Included	RRP in £*	Order no.
Storage shelf, Storage trough, Storage base for pegboard, Double tool hook, Double universal hook, 6 standard hooks (125 mm long), 2 pegboards with square holes, SYSTAINER retainer, in a carton		
<b>WCR 1000</b>	315,00 378,00	<b>497471</b>

\* Recommended retail price of manufacturer. Dealer prices may vary.  
Excl. VAT.  
Incl. VAT.

### System accessories from page 372







## Workplace organisation

Multifunction stool MFH 1000  
and Universalcenter UCR 1000

# MFH 1000 / UCR 1000

### More tidiness. More speed.

- ▶ Multifunction stool MFH 1000 + Workcenter WCR 1000 = Universalcenter UCR 1000
- ▶ Use the Universalcenter UCR 1000 in mobile applications and benefit from the advantages of the Workcenter WCR 1000
- ▶ Pleasant working environment – without the Workcenter WCR, the multifunction stool MFH 1000 is a stable, comfortable seat
- ▶ Efficient organisation – hooks and storage trays ensure quick access to machines, accessories and work equipment

Technical data	UCR 1000	MFH 1000
Length (mm)	695	
Dimensions (L x W x H) (mm)		695 x 436 x 524
Width (mm)	436	
Height adjustable (mm)	1031-1271	
Width of roller (mm)	32	32
Roller Ø (mm)	100	100
Inner hole distance of square hole pattern (mm)	38,1	38,1
Size of square hole pattern (mm)	9,2 x 9,2	9,2 x 9,2
weight (kg)	37	27

Items Included	RRP in £*	Order no.
in a carton		
<b>MFH 1000</b>	255,00	<b>498967</b>
seat cushion MFH 1000 SK, Assembly set	306,00	
<b>UCR 1000</b>	536,00	<b>498966</b>
WCR 1000 Workcenter, multifunction stool MFH 1000 (without seat cushion)	643,20	



### Clever, mobile organisation.

Pull-out drawer that can be locked – for storing accessories, work equipment and personal effects.

\* Recommended retail price of manufacturer. Dealer prices may vary.  
Excl. VAT.  
Incl. VAT.

System accessories  
from page 372



## Workplace organisation

Toolcenter TC 3000/2

# TC 3000/2



### Safety included.

Locking cabinet compartment for size 3 SYSTAINERS or smaller provides safe storage for machines and accessories.



### Flexibility and extra work space.

- ▶ Beneficial organisation – tools, materials and mobile dust extractor are always stored away tidily and close at hand
- ▶ Mobile equipment – simple transportation between different locations in the workshop
- ▶ Secure attachment – the mobile dust extractor is secured safely in the extractor dock
- ▶ More space – machine and hose holders keep storage areas free for working equipment

#### Technical data

Dimensions (L x W x H) (mm)	470 x 1070 x 960
Storage area (mm)	460 x 990
Storage area working height (mm)	925
weight (kg)	43

Items Included	RRP in £*	Order no.
hose holder, anti-slip mat, in a carton		
<b>TC 3000/2</b>	521,00 625,20	<b>583881</b>

\* Recommended retail price of manufacturer. Dealer prices may vary.  
Excl. VAT.  
Incl. VAT.

#### System accessories from page 373

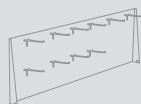

## Workplace organisation

### SYSLITE KAL II working light



2012



## SYSLITE KAL II

### The light to the tool.

- ▶ Outstanding illumination with 12 high-performance LEDs and a choice of intensive or dimmed light
- ▶ Long life and robust thanks to shatter-proof housing
- ▶ Continuous use – any Festool battery pack can be attached to supplement the internal battery. The 240 V mains power pack and vehicle charging cable offer additional charging and power supply options
- ▶ Universal spherical head with magnet and clamp attachment

#### Technical data

Light source (W)	12 x 1,5
Lux value (average measurement on 1m <sup>2</sup> )	133
Duration (internal battery) 1st/2nd stage (min)	290/110
Li-Ion battery capacity (Ah)	2,9
Charging time Li Ion (min)	200
Permissible operating temperature range (°C)	-5/+ 55
Operation with external Festool battery packs (V)	12-18
Hook opening (mm)	40
Thread size stand (")	1/4
Dimensions (L x W x H) (mm)	80 x 100 x 150
Weight (without external battery pack) (kg)	0,7

#### Items Included

	RRP in £*	Order no.
integrated lithium-ion battery 7.2 V, charger adapter 240 V, car charger adapter, transport bag, in self-service display pack		
<b>KAL II GB 240V</b>	130,00 156,00	<b>500722</b>
<b>KAL II-Set GB 240V</b>	153,00	<b>499816</b>
magnetic spherical head with flat disc	183,60	



### Total flexibility.

5 available installation and mounting positions: The SYSLITE lights up the darkest of corners for up to 6 hours non-stop. The housing is made from shatter-proof, shock-proof and impact-resistant cast aluminium – durable enough for any construction site. The light dispersion angle of 170° ensures extensive, homogeneous illumination of the work space.

\* Recommended retail price of manufacturer. Dealer prices may vary.  
Excl. VAT.  
Incl. VAT.

#### Magnet spherical head Order No. 499814



## Workplace organisation

SYSTAINER T-LOC, SORTAINER, SYS-ToolBox

### Simply tidier, more clearly arranged and better organised.

SYSTAINERS and SORTAINERS from Festool.

### SYSTAINER/SORTAINER – can be stacked or connected, are extremely robust and virtually indestructible.

Machines, accessories and consumable materials are protected from dust, water, changes in temperature and heavy impacts. All your sundries and consumables are stored tidily and are easier to transport – size 1 and 2 SYS T-LOC units can even be carried upright with the attachable additional handle (accessory).

### SYS-ToolBox – the open SYSTAINER for instant access.

A robust design made from high-quality plastic provides a maximum load capacity of 7 kg. Two spacious compartments keep your workplace tidy and an open top gives quick access to hand tools, consumable materials and accessories.



#### Combines three functions.

The central control element of the SYSTAINER: Lock, open, connect with a single turn.



#### Secure connection.

In combination with a SYSTAINER or a mobile dust extractor, Systainer-Port and Workcenter WCR.



#### Easy to open.

The new SYSTAINER T-LOC can be opened at any time without having to be disconnected.



### Everything at a glance – the drawers of the SORTAINER offer lots of space for sundries..

1. Individual compartments and additional labelling options provide a better overview.
2. From the left or right. The drawers can be opened from both sides to allow quick access to the contents.
3. The pull-out catch and individual safety lock prevent accidental removal of the drawers.
4. A range of different sizes and a modular drawer system offer a SORTAINER to suit every requirement.



# Workplace organisation

## SYS-Port, SYS-Roll, SYS-Cart



### Good for quick transportation.

Everything in its place, stored close at hand at all times. The Systainer-Port, roll board and SYS-Roll SYSTAINER transporter provide greater mobility at the workplace and on assembly sites.



### How many SYSTAINERS fit in a SYS-PORT? Combination options

SYSTAINER size	SYS-PORT 500/2						SYS-PORT 1000/2																																				
	Number of SYSTAINERS						Number of SYSTAINERS																																				
Version	1	2	3	4	5	6	1	2	3	4	5	6	7	8	9	10	11	12	13	14	15	16	17	18	19	20	21	22	23	24	25	26	27	28	29	30	31	32	33				
<b>SYS 1 T-LOC/DF*</b>	3	2	1				8	6	6	5	5	4	4	3	3	3	3	2	2	2	2	2	1	1	1													2	4	1	1		
<b>SYS 2 T-LOC/DF*</b>		1	2	1				1	2	1	1	2	3		1	2	4					2	3	1	1	2	3	4	5											2			
<b>SYS 3 T-LOC/DF*</b>			1	1					1		1	2	1	1	2			3				2	1	2		3	1	1		4	1	1								2			
<b>SYS 4 T-LOC/DF*</b>					1					1		1		1		1					2		1	2		1	1					2							1				
<b>SYS 5 T-LOC/DF*</b>																																						1	1	2	1	1	1
Drawers required**	3	3	2	2	2	1	8	7	7	7	6	6	6	6	5	6	6	5	5	5	5	6	5	4	5	5	4	3	4	4	4	5	5	4	3	4	5	2	3	3	4		

\* DF = Lid compartment    \*\* The SYS-PORT 500/2 is supplied with 3 drawers, the SYS-PORT 1000/2 with 5 drawers.

### From machines to sundries. From the workshop to the assembly site.

	SYSTAINER 1-5 SYS-MFT	SORTAINER	SYS-ToolBox SYS-StorageBox	MAXI- SYSTAINER	MIDI- SYSTAINER	MINI- SYSTAINER	SYS-Roll	SYS-Cart	Systainer- Port
Organisation/Storage									
Power tools	1	2		1					3
Sundries	1					1			3
Abrasives	1								3
Cartridges	1								3
Hand tool	1								3
Combinations									
SYSTAINER 1-5									
SORTAINER									
SYS-ToolBox I/II									
MAXI-SYSTAINER									
MIDI-SYSTAINER									
MINI-SYSTAINER									
SYS roller									
SYS-Cart									
Systainer-Port									
CT mobile dust extractors									
Use/Transportation									
Workshop									
Construction site									

● Extremely appropriate    ● Very appropriate    ○ Appropriate  
<sup>1</sup> In combination with insert    <sup>2</sup> Only with Sys 3-Sort/4  
<sup>3</sup> In combination with a suitable SYSTAINER or SORTAINER

### **The Festool system.**

Because things work better when everything fits together:  
Workplace organisation is at least as important as an accurate  
power tool, because ultimately almost inexhaustible potential lies  
behind this. The Festool system always creates a tidy environment  
and guarantees better organisation.



## Workplace organisation

Accessories and consumable materials



# Workplace organisation

## System accessories

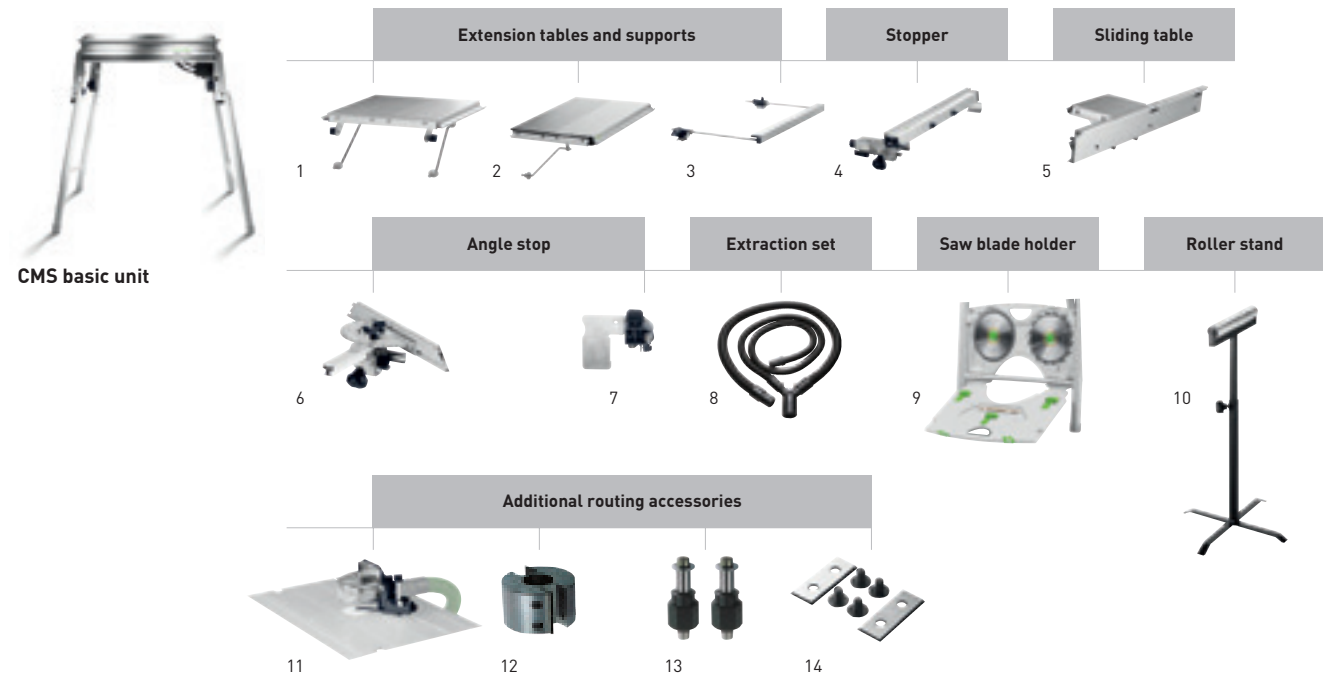

### Accessories for Compact Module System CMS

Denomination	Explanation	RRP in £*	Order no.
1 Extension table VL	for CS 50, CMS-GE, simple fitting, folds away, enlarges the support surface by 405 mm, for safe support of long workpieces when sawing to width, dimensions length x width 375 x 454 mm, in a carton	165,05 198,06	492092
2 Extension table VB-CMS	for CMS-GE, with adjustable dimension scale, extends the support area by 410 mm, Cutting width 570 mm, dimensions length x width 664 x 438 mm, in a carton	212,35 254,82	493822
3 Support AF	for CS 50, CMS-GE, support for both side use, supports workpieces while cutting, enlarges the support surface by 300 mm, dimensions length x width 662 x 390 mm, in a carton	70,90 85,08	492242
4 Stopper LA-CS 50/CMS	for CS 50, CMS-GE, with fine adjustment and rear clamp, can be operated from front, with moveable stop profile for precise and safe longitudinal cuts, in a carton	171,00 205,20	492095
5 Sliding table ST	for CS 50, CMS-GE, max. working width for trimming cuts 830 mm, in a carton	235,80 282,96	492100
6 Angle stop WA	for CS 70, CS 50, CMS-GE, for work requiring 2 stops, in a carton	114,90 137,88	488451
7 Adjustable stop WA-AR	for CS 50, CS 70, to stop workpieces on trimming attachment CS 70 WA, CS 50 WA and Basis WRA 500, in self-service display pack	25,40 30,48	491712
8 Dust extraction set CS 70 AB	for CT/CTM, can be used with Basis, CS 70, CS 50 and CMS, comprising: dust extraction hose D27x2.0 m, dust extraction hose D36x1.0 m, Y terminal, (not compatible with CTL MINI/MIDI), Diameter 27/36 mm, in a carton	71,95 86,34	488292
Adapter hose AD-D36/CS50/CS70/CMS	for CS50, CS 70, CMS, 0.5 m hose D36 with two rotating adapters and connection coupling, anti-static D50/D50 VM-AS, for Y-shaped connection in conjunction with CTL MINI/MIDI, in a carton	26,35 31,62	499196
9 Saw blade holder SGA	for CS 50, CMS-GE, for safe and space-saving storage of up to 4 saw blades (max. Ø 190 mm) and up to 3 splinterguards (not included in contents), in a carton	34,30 41,16	492228
10 Roller stand RB	for all semi-stationary devices (CS/KS/CMS), to use longer workpieces for longitudinal sections and cross sections and cutting and grinding work, may be used with the CS 50, CS 70, CB 120, Basis Plus System, CMS-GE, multifunction table, height adjustable 630 – 1000 mm, in a carton	125,75 150,90	488711
11 Guard BF-OF-CMS	for CMS-OF 1010, for CMS-OF 1400/OF 2000/OF 2200, guard and extractor hood, connection Ø d/e 27/36 mm, in a carton	43,40 52,08	494643
12 Rebating head FK D 50x30	for CMS-OF, for use with cutter spindles, Diameter 50 mm, in self-service display pack	90,90 109,08	489284
13 Cutter spindle ASL20/OF1400-OF2200	for CMS-OF 1400/OF 2000/OF 2200, for use with rebating head Basis FK D 50x30 in the Basis 6 A and CMS-OF, in self-service display pack	34,40 41,28	490131
Cutter spindle ASL20/OF1010	for CMS-OF, allows use of rebating head Basis FK D 50x30 in the Basis 5 A and CMS-OF 1010, in self-service display pack	29,05 34,86	489285
14 Reversible blade WP 30x12x1,5	for rebating head, qty. in pack 2 piece(s), in self-service display pack	18,30 21,96	489286



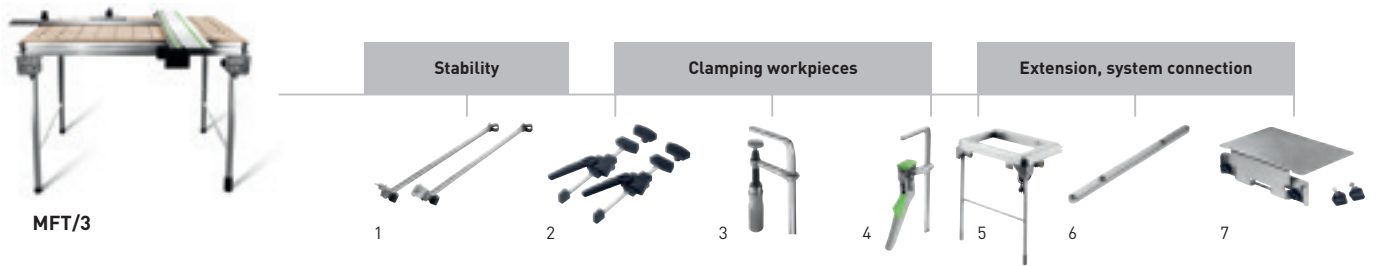

### Accessories for the MFT 3 multifunction table

Denomination	Explanation	RRP in £*	Order no.
<b>1 Cross brace MFT 3-QT</b>	for additional MFT 3 stability, qty. in pack 2 piece(s), Diameter 20 mm, Length 675 mm, in a carton	71,00 85,20	<b>495502</b>
<b>2 Fixed clamps MFT-SP</b>	for MFT, for safe and precise securing of the workpiece (sawing, sanding, routing, drilling, etc.), qty. in pack 2 piece(s), in self-service display pack	72,90 87,48	<b>488030</b>
<b>3 Fastening clamp FSZ 120</b>	for MFT, solid steel version, Span 120 mm, qty. in pack 2 piece(s), in self-service display pack	28,80 34,56	<b>489570</b>
<b>Fastening clamp FSZ 300</b>	for MFT, solid steel version, Span 300 mm, qty. in pack 2 piece(s), in self-service display pack	35,75 42,90	<b>489571</b>
<b>4 Lever clamp FS-HZ 160</b>	for MFT, solid steel version, Span 160 mm, in self-service display pack	40,10 48,12	<b>491594</b>
<b>5 Guide extension MFT 3-VL</b>	for the MFT 3, foldaway legs, main safety switch, cable and socket, in a carton	339,00 406,80	<b>495510</b>
<b>6 Connecting piece VS</b>	for attachment of FST660/85 or MFT 800 to Basis Plus, for connecting several MFT 3, in self-service display pack	10,45 12,54	<b>484455</b>
<b>7 Adapter VAC SYS AD MFT 3</b>	for VAC SYS SE 1, VAC SYS SE 2, for connecting the VAC SYS clamping unit with the MFT 3, in a carton	177,00 212,40	<b>494977</b>

## Workplace organisation

### System accessories

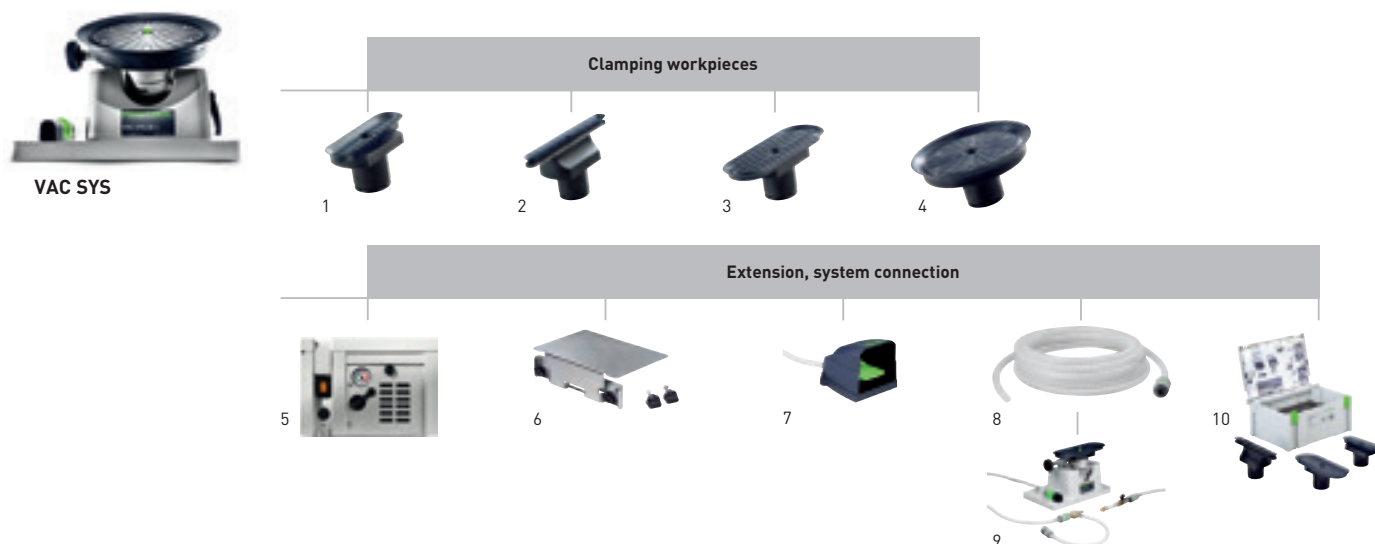

### Accessories for the VAC SYS vacuum clamping system

Denomination	Explanation	RRP in £*	Order no.
1 Vacuum pad VAC SYS VT 200x60	for VAC SYS SE 1, VAC SYS SE 2, pad dimensions 200x60 mm, in a carton	62,55 75,06	580064
2 Vacuum pad VAC SYS VT 277x32	for VAC SYS SE 1, VAC SYS SE 2, pad dimensions 277x32 mm, in a carton	93,10 111,72	580065
3 Vacuum pad VAC SYS VT 275x100	for VAC SYS SE 1, VAC SYS SE 2, pad dimensions 275x100 mm, in a carton	73,30 87,96	580066
4 Vacuum pad VAC SYS VT D 215	for VAC SYS SE 1, VAC SYS SE 2, Diameter 215 mm, in a carton	73,30 87,96	580067
5 Vacuum pump VAC SYS VP	power consumption at 50 Hz 160-200 W, power consumption at 60 Hz 200-230 W, pump capacity at 50 Hz 2,7 m <sup>3</sup> /h, pump capacity at 60 Hz 3,5 m <sup>3</sup> /h, minimum vacuum ≥ 81%/ ≥ 810 mbar, weight 8 kg, in a carton	501,00 601,20	580072
6 Adapter VAC SYS AD MFT 3	for VAC SYS SE 1, VAC SYS SE 2, for connecting the VAC SYS clamping unit with the MFT 3, in a carton	177,00 212,40	494977
7 Foot valve VAC SYS FV	for the VAC SYS SE 1 or in a combination of the VAC SYS SE 1 with the VAC SYS SE 2, for releasing the vacuum pad, in a carton	68,30 81,96	580063
8 Vacuum hose D 16 x 5m VAC SYS	for VAC SYS Set SE 1 and VAC SYS SE2, for guide extension, Length 5 m, in a carton	68,30 81,96 13,66 / 1 m 16,39 / 1 m	495293
9 Vacuum unit VAC SYS SE 2	vacuum pad VAC SYS VT 275 x 100 mm, vacuum hose, connector, power consumption at 50 Hz 160-200 W, power consumption at 60 Hz 200-230 W, pump capacity at 50 Hz 2,7 m <sup>3</sup> /h, pump capacity at 60 Hz 3,5 m <sup>3</sup> /h, minimum vacuum ≥ 81%/ ≥ 810 mbar, weight 8 kg, in a SYSTAINER SYS 4	410,00 492,00	580062
10 Accessories SYSTAINER VAC SYS VT Sort	for VAC SYS SE 1, VAC SYS SE 2, also provides space for the VAC SYS VT D 215, VAC SYS VT 200x60, VAC SYS VT 277x32, VAC SYS VT 275x100, also provides space for the VAC SYS VT D 215, in a SYSTAINER SYS 3	246,10 295,32	495294

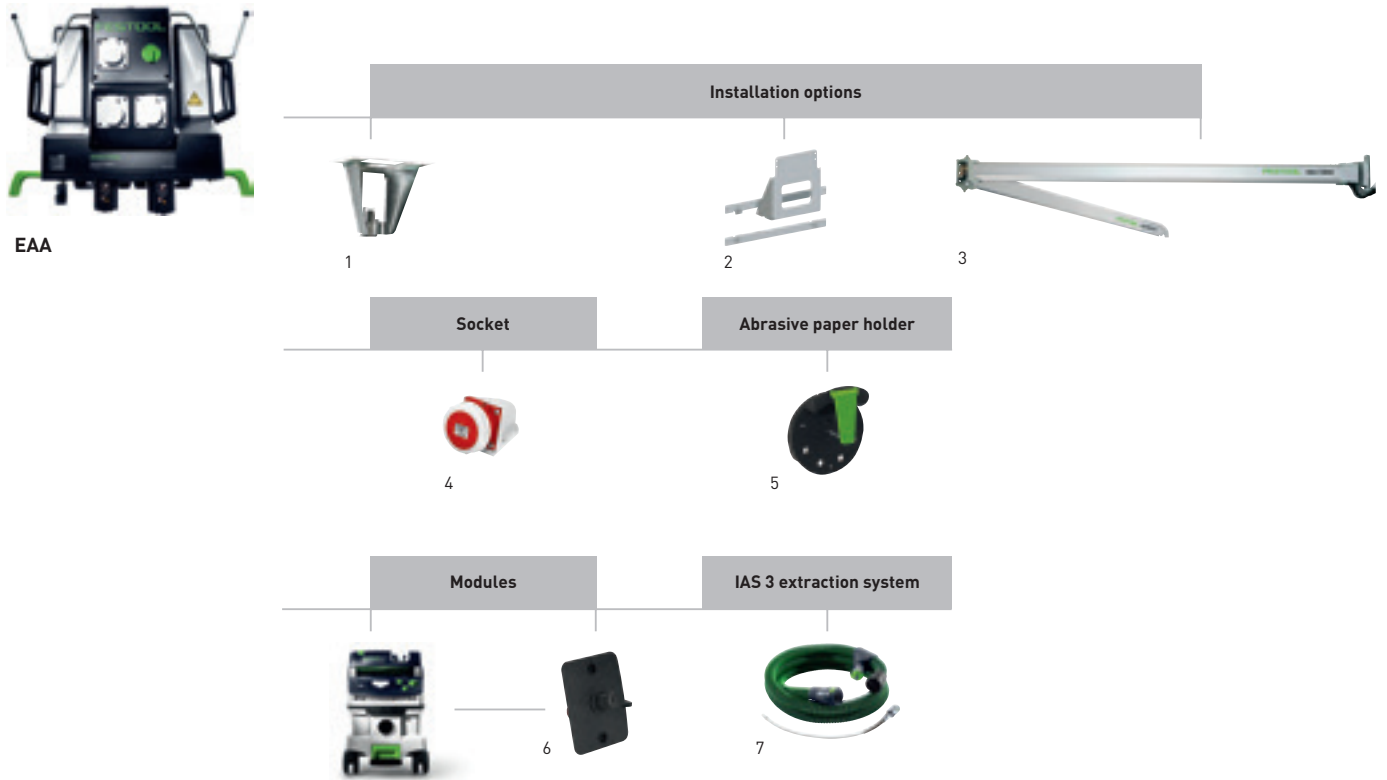

### Accessories for the ASA boom arm, EAA energy box

Denomination	Explanation	RRP in £*	Order no.
<b>1 Ceiling suspension EAA-D-EU</b>	for energy boxes (models starting in 2009), 2.5 m cable set, 2.5 m compressed air hose, mounting, aluminium tube (1310 mm) with connecting sleeve, in a carton	313,70 376,44	<b>495890</b>
<b>2 Wall mounting EAA-W-EU</b>	for energy boxes (models starting in 2009), 4 m cable sets, 4 m compressed air hose, aluminium tube (350 mm) with connecting sleeve, installation set for energy boxes, in a carton	231,65 277,98	<b>495889</b>
<b>3 Boom arm ASA 5000 CT/SR-EU</b>	for CT mobile dust extractors and SRM extractors, double-jointed arm with wall bracket, cable duct, wall mounting components are not included, connecting line length 3 m, weight 92 kg, boom extension 2 x 2,5 m, cutting angle adjustment 39-58°, in a carton	2.087,00 2.504,40	<b>583867</b>
<b>Boom arm ASA 6000 CT/SR-EU</b>	for CT mobile dust extractors and SRM extractors, double-jointed arm with wall bracket, cable duct, wall mounting components are not included, connecting line length 3 m, boom extension 2 x 3,0 m, cutting angle adjustment 56-84°, weight 105 kg, in a carton	2.181,00 2.617,20	<b>583868</b>
<b>4 Socket CEE 400V-EAA (IP67)</b>	400 V socket for EAA, three-phase socket mounted on the back next to the service unit is connected to on-site power supply, in a carton	55,40 66,48	<b>543984</b>
<b>5 Abrasive paper holder SH-EAA</b>	for abrasives up to Ø 150 mm, without mounting hardware, in a carton	20,05 24,06	<b>496044</b>
<b>6 Energy box module EAA CT 26/36/48</b>	for CT 26/36/48, for connecting a CT mobile dust extractor with an energy box or boom arm, not required in LE version, in a carton	49,65 59,58	<b>496143</b>
<b>7 IAS 3 hose</b>	see chapter Surface finishing on page 109		

# Workplace organisation

## System accessories

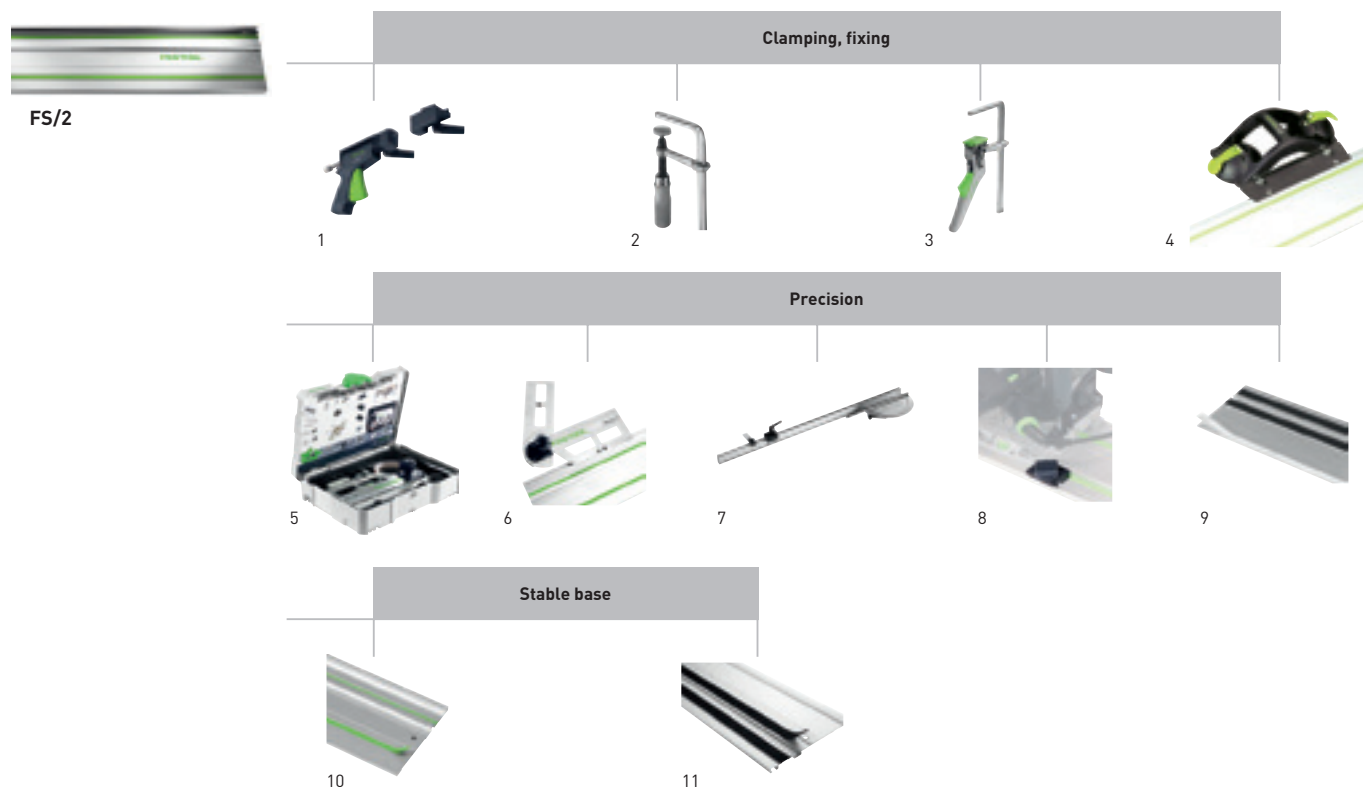

### Accessories for the guide rail FS/2

Denomination	Explanation	RRP in £*	Order no.
<b>1 Quick-action clamp FS-RAPID/R</b>	for clamping and positioning the Festool guide rails FS and FS/2, clamping jaws, fixed jaws, in self-service display pack	34,40 41,28	<b>489790</b>
<b>Quick-action clamp FS-RAPID/L</b>	for use of SSU 200, IS 330 with guide rail, for clamping and positioning guide rails FS, FS/2 and GRP/2, Clamping jaws, fixed jaws, in self-service display pack	35,70 42,84	<b>768116</b>
<b>2 Fastening clamp FSZ 120</b>	for MFT, solid steel version, Span 120 mm, qty. in pack 2 piece(s), in self-service display pack	28,80 34,56	<b>489570</b>
<b>Fastening clamp FSZ 300</b>	for MFT, solid steel version, Span 300 mm, qty. in pack 2 piece(s), in self-service display pack	35,75 42,90	<b>489571</b>
<b>3 Lever clamp FS-HZ 160</b>	for MFT, solid steel version, Span 160 mm, in self-service display pack	40,10 48,12	<b>491594</b>
<b>4 GECKO DOSH dual suction pad</b>	from page 354		
<b>Adapter DOSH-FSAD</b>	to fix the guide rail at the GECKO, in self-service display pack	15,75 18,90	<b>492616</b>
<b>5 Accessories set FS-SYS/2</b>	2 clamps FSZ 120, deflector FS-AW, combination angle FS-KS, set-back stop FS-RSP, 2 connecting elements FSV, splinter guard FS-SP 1400, in a SYSTEMAINER SYS 1 T-LOC	128,25 153,90	<b>497657</b>
<b>6 Combination bevel FS-KS</b>	for FS/2, for angle cuts on guide rail between 0 and 180, in self-service display pack	70,50 84,60	<b>491588</b>
<b>7 Angle stop FS-AG-2</b>	for FS/2 and GRP/2, for straight angle cuts for use with the guide rail, in a carton	102,15 122,58	<b>768168</b>
<b>8 Kickback stop FS-RSP</b>	for TS 55, TS 55 R, TSC 55, TS 75, ATF 55, AP 55, AT 65, AP 65, AP 85, used as a rear and front stop position on guide rail FS/2, can also be used as guide stop, in self-service display pack	12,25 14,70	<b>491582</b>
<b>9 Splinter guard FS-SP 1400/T</b>	replacement splinterguard for guide rails, transparent, Length 1400 mm, in self-service display pack	8,30 9,96	<b>495207</b>
<b>Splinter guard FS-SP 5000/T</b>	replacement splinterguard for guide rails, transparent, Length 5000 mm, in self-service display pack	20,50 24,60	<b>495209</b>
<b>10 Slideway lining FS-GB 10M</b>	replacement sliding surface for guide rail, 10 m length, in self-service display pack	26,10 31,32	<b>491741</b>
<b>11 Adhesive cushion strip FS-HU 10M</b>	replacement adhesive strips for guide rails, in 10 m rolls, in self-service display pack	14,45 17,34	<b>485724</b>

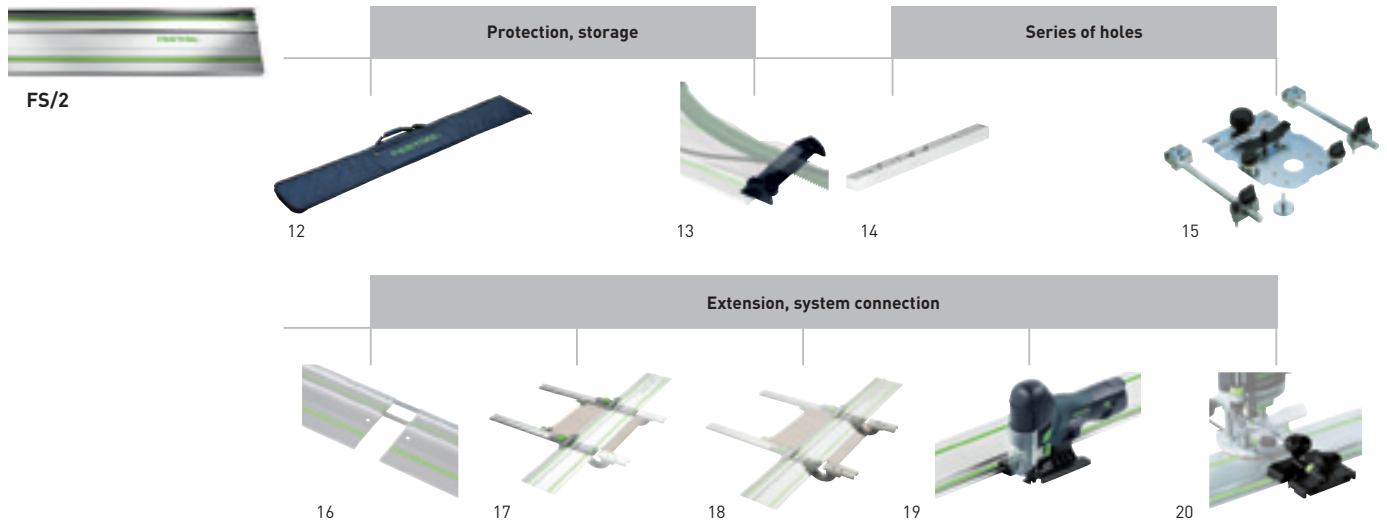

### Accessories for the guide rail FS/2

Denomination	Explanation	RRP in £*	Order no.
12 <b>Bag FS-BAG</b>	up to length of FS 1400/2, carrying bag with shoulder straps, in a carton	52,10 62,52	<b>466357</b>
13 <b>Deflector FS-AW</b>	prevents suction hoses and cables from catching on the end of the guide rail, in self-service display pack	15,10 18,12	<b>489022</b>
14 <b>Stopper LA-LR 32 FS</b>	positions the first hole on the hole series guide rail at a distance of 9,5, 16 or 32 mm from the workpiece edge, qty. in pack 2 piece(s), in self-service display pack	39,75 47,70	<b>496938</b>
15 <b>Hole series system for FS/2</b>	from page 157		
16 <b>Connecting piece FSV</b>	to connect guide rails for long workpieces, qty. in pack 1 piece(s), in self-service display pack	12,60 15,12	<b>482107</b>
17 <b>Parallel side fence FS-PA</b>	for FS/2, for sawing along the width, for fixed cuts, can be re-set using the scale and end stop, mounting on the guide rail without the use of tools, stop ruler, clamp, adjustable stop, max. workpiece width 650 mm, qty. in pack 2 piece(s), in self-service display pack	163,00 195,60	<b>495717</b>
18 <b>Guide extension FS-PA-VL</b>	for FS/2, only for use with the FS-PA, bridge, stop ruler, scale, max. workpiece width 195 mm, max. material strength 70 mm, qty. in pack 2 piece(s), in self-service display pack	96,80 116,16	<b>495718</b>
19 <b>Guide rail adapter FS-PS/PSB 300</b>	for PS 200, PS 300, PSB 300, PS 2, allows use of jigsaws with FS and FS/2 guide systems, in self-service display pack	11,30 13,56	<b>490031</b>
<b>Adapter table ADT-PS 420</b>	for PS 400/420, for using the PS on the guide rail, for installation in the Compact Module System CMS, in conjunction with circle cutting attachment KS-PS 400, in self-service display pack	11,40 13,68	<b>497303</b>
20 <b>Guide stops for routers</b>	from page 156, 158, 159		

## Workplace organisation

### System accessories



WCR 1000



UCR 1000



MFH 1000

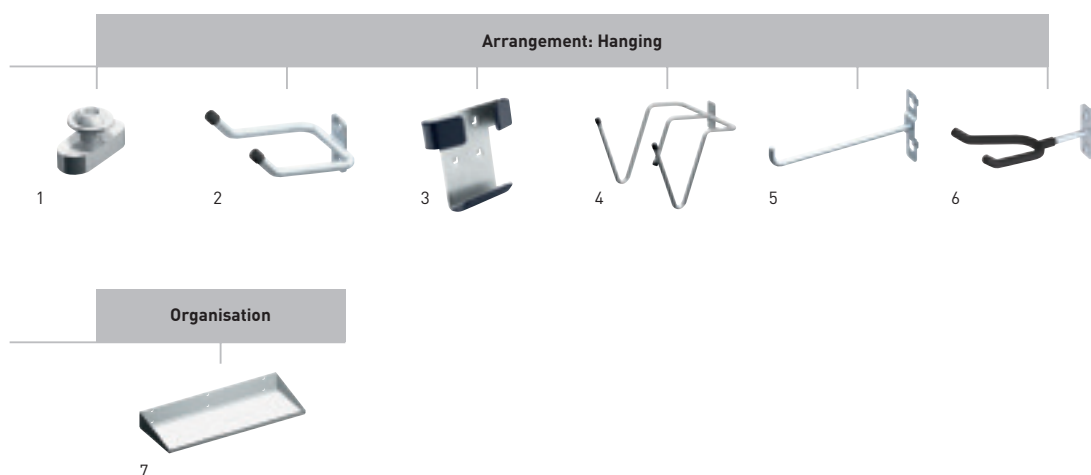

#### Accessories for Workcenter WCR 1000, Universalcenter UCR 1000, multifunction stool MFH 1000

Denomination	Explanation	RRP in €*	Order no.
1 Feather key WCR 1000 PF 2x	for WCR 1000, UCR 1000, The keys enable the attachment of individual accessories to the profiled groove, 2x keys incl. bits, in a carton	9,65 11,58	497476
2 Universal hook WCR 1000 UH	for WCR 1000, UCR 1000, for hanging different tools, for use as a hose holder, in a carton	32,15 38,58	497473
3 Pegboard hook HSK LWH HSK-A	for WCR 1000, MFH 1000, UCR 1000, the protective coating prevents damage, not suitable for hand sanding block HSK-A 80x400, for hanging hand sanding blocks HSK-A 80x130, HSK-A 80x200 and HSK-A 115x226, dimensions length x width 38,1 x 38,1 mm, in self-service display pack	25,40 30,48	498968
4 Tool hook WCR 1000 WH	for WCR 1000, UCR 1000, for hanging two tools, for use as a hose holder, in a carton	44,85 53,82	497474
5 Hook WCR 1000 SHQ	for WCR 1000, UCR 1000, Standard hooks for mounting on the pegboard, qty. in pack 6 piece(s), in a carton	16,80 20,16	497475
6 Holder for spray gun WCR 1000 LPH	for WCR 1000 Workcenter, holder for paint gun, for assembly at the profile groove for the WCR 1000 Workcenter, 2x screw, 2x square nut, Dimensions (L x W x H) 148 x 76 x 60 mm, weight 0,5 kg, in a carton	20,60 24,72	498361
7 Storage surface WCR 1000 AB	for WCR 1000, UCR 1000, Large storage surface for placing sundries, boxes of abrasives or screws, etc., in a carton	34,10 40,92	497477



TC 3000/2

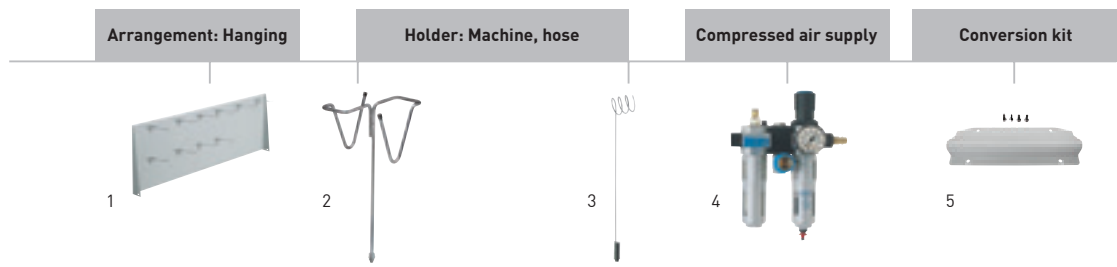









### Accessories for the TC 3000/2 Toolcenter

Denomination	Explanation	RRP in £*	Order no.
<b>1 Rear wall TC 3000 RW</b>	for Toolcenters TC 3000, TC 3000/2 incl. 10 hooks, dimensions length x width 990 x 340 mm, in a carton	127,60 153,12	<b>452986</b>
<b>2 Tool holder WHR/D-TC</b>	for the TC 2000, TC 3000, TC 3000/2, for safe, ergonomic storage of two electric and air tools at the same time, in a carton	42,30 50,76	<b>493415</b>
<b>3 Hose holder TC-SH</b>	for the TC 2000, TC 3000, TC 3000/2, for retrofitting TC 3000, in a carton	45,55 54,66	<b>487304</b>
<b>4 Service unit VE-TC 3000</b>	for Toolcenter TC 2000, TC 3000, for compressed air supply to mobile dust extractors CT 22/33 and SR 151, SR 200 series dust extractors in LE design, in a carton	349,55 419,46	<b>454808</b>
<b>5 Conversion kit UBS TC 3000 CT26/36</b>	for TC 3000, for conversion of the TC 3000, for supporting the CT 26/36, in a carton	38,70 46,44	<b>496371</b>



## Workplace organisation

### System accessories





SYSTAINER T-LOC		Type	RRP in £*	Order no.
	<b>SYSTAINER T-LOC</b> 1x cover for label field			
	Dimensions (L x W x H) 396 x 296 x 105 mm, dimensions with floor stand (L x W x H) 396 x 296 x 112 mm, inner dimensions (L x W x H) 383 x 273 x 75 mm, weight 1,3 kg	SYS 1 TL	41,75 50,10	<b>497563</b>
	Dimensions (L x W x H) 396 x 296 x 157,5 mm, dimensions with floor stand (L x W x H) 396 x 296 x 164,5 mm, inner dimensions (L x W x H) 383 x 267 x 127,5 mm, weight 1,5 kg	SYS 2 TL	45,45 54,54	<b>497564</b>
	Dimensions (L x W x H) 396 x 296 x 210 mm, dimensions with floor stand (L x W x H) 396 x 296 x 217 mm, inner dimensions (L x W x H) 382 x 266 x 180 mm, weight 1,8 kg	SYS 3 TL	49,30 59,16	<b>497565</b>
	Dimensions (L x W x H) 396 x 296 x 315 mm, dimensions with floor stand (L x W x H) 396 x 296 x 322 mm, inner dimensions (L x W x H) 382 x 266 x 285 mm, weight 2,1 kg	SYS 4 TL	52,90 63,48	<b>497566</b>
	Dimensions (L x W x H) 396 x 296 x 420 mm, dimensions with floor stand (L x W x H) 396 x 296 x 427 mm, inner dimensions (L x W x H) 381 x 265 x 384 mm, weight 2,7 kg	SYS 5 TL	56,55 67,86	<b>497567</b>
MAXI-SYSTAINER		Type	RRP in £*	Order no.
	<b>MAXI-SYSTAINER</b> to connect with SYS 1, SYS 2, SYS 3, SYS 4, SYS 5, SORTAINER			
	Dimensions (L x W x H) 590 x 390 x 210 mm, weight 4,0 kg	SYS MAXI	72,65 87,18	<b>490701</b>
	Dimensions (L x W x H) 590 x 390 x 157,5 mm, weight 3,0 kg	SYS MAXI 2	66,45 79,74	<b>492582</b>
MIDI-SYSTAINER T-LOC		Type	RRP in £*	Order no.
	<b>MIDI-SYSTAINER T-LOC</b> can be connected to SYS T-LOC, for clear and structured arrangement of small parts, power tools, hand-hand tools and accessories, Dimensions (L x W x H) 503 x 296 x 210 mm, weight 2,0 kg	SYS-MIDI 3 TL	62,30 74,76	<b>499621</b>
MINI-SYSTAINER T-LOC		Type	RRP in £*	Order no.
	<b>MINI-SYSTAINER T-LOC</b> for clear and structured arrangement of small parts and hand-held tools, cannot be connected to SYS 1, SYS 2, SYS 3, SYS 4, SYS 5, SORTAINER, SYS MINI classic, Dimensions (L x W x H) 265 x 171 x 71 mm, weight 0,4 kg	SYS-MINI TL	13,65 16,38	<b>499622</b>





### SYSTAINER SYS T-LOC with lid compartment

	Type	RRP in £*	Order no.
 <p><b>SYSTAINER T-LOC DF</b> 1x cover for label field</p>			
	Dimensions (L x W x H) 396 x 296 x 105 mm, dimensions with floor stand (L x W x H) 396 x 296 x 112 mm, inner dimensions (L x W x H) 383 x 273 x 68 mm, weight 1,5 kg	SYS 1 TL-DF	54,15 64,98
 <p>Dimensions (L x W x H) 396 x 296 x 157,5 mm, dimensions with floor stand (L x W x H) 396 x 296 x 164,5 mm, inner dimensions (L x W x H) 383 x 267 x 121 mm, weight 1,7 kg</p>	SYS 2 TL-DF	54,15 64,98	<b>497852</b>
	Dimensions (L x W x H) 396 x 296 x 210 mm, dimensions with floor stand (L x W x H) 396 x 295 x 217 mm, inner dimensions (L x W x H) 382 x 266 x 173 mm, weight 2 kg	SYS 3 TL-DF	56,80 68,16

### SORTAINER

	Type	RRP in £*	Order no.
 <p><b>SORTAINER</b> 2 dividers per drawer, Dimensions (L x W x H) 395 x 295 x 210 mm</p>			
	2 small drawers, medium drawer (L x W x D) 255 x 165 x 30 mm, large drawer (L x W x D) 255 x 348 x 85 mm, 8 label holders, 8 lettering strips, weight 4,0 kg	SYS 3-SORT/4	99,60 119,52
 <p>6 medium drawers (L x W x T) 255 x 165 x 30 mm, 8 label holders, 8 lettering strips, weight 4,9 kg</p>	SYS 3-SORT/6	110,65 132,78	<b>491984</b>
 <p>6 small drawers (L x W x T) 255 x 75 x 30 mm, 3 medium drawers (L x W x T) 255 x 165 x 30 mm, 9 label holders, 16 labels, weight 5,1 kg</p>	SYS 3-SORT/9	110,65 132,78	<b>491985</b>
 <p>12 small drawers (L x W x T) 255 x 75 x 30 mm, 12 label holders, 16 labels, weight 5,3 kg</p>	SYS 3-SORT/12	110,65 132,78	<b>491986</b>

### SYS tool box









	Type	RRP in £*	Order no.
 <p><b>SYS tool box</b> for practical transportation of hand tools, consumable materials and accessories, contact surface 396 x 296 mm</p>			
	Height 150 mm, carrying power 7 kg, volume 12,5 l	SYS-TB-1	33,65 40,38
 <p>Height 257 mm, carrying power 14 kg, volume 20 l</p>	SYS-TB-2	42,20 50,64	<b>499550</b>

### SYS-StorageBox





	Type	RRP in £*	Order no.
 <p><b>SYS-StorageBox</b> plastic container, no content, with individually removable plastic containers, 2 x Box 60x60x71 SYS-SB, 2 x Box 60x60x71 SYS-SB, 2 x Box 180x120x71 SYS-SB, can be connected to the entire Systainer range (except SYS-Mini), Dimensions (L x W x H) 396 x 296 x 167 mm, height including handle 240 mm, weight 2,5 kg</p>			
	SYS-SB	74,70 89,64	<b>499901</b>

## Workplace organisation

### System accessories











Systainer-Port		Type	RRP in £*	Order no.
	<b>Systainer-Port</b> no admission for assembly in car, stable full metal body, 5 labels for drawers, without SYSTAINER, in a carton			
	with 3 SYSTAINER telescopic drawers, Dimensions (L x W x H) 400 x 500 x 500 mm, weight 19 kg	SYS-PORT 500/2	330,90 397,08	<b>491921</b>
	with 5 SYSTAINER telescopic drawers, with roller set, 4 ball bearing-mounted swivel castors (2 with locking brakes), Dimensions (L x W x H) 400 x 500 x 1100 mm, weight 33 kg	SYS-PORT 1000/2	445,20 534,24	<b>491922</b>
Systainer pull-out		Type	RRP in £*	Order no.
	<b>Pull-out drawer</b> for all Systainers (Classic and T-LOC), for constructing an individual shelf system, in 32 hole grid, Dimensions (L x W x H) 426 x 373 x 57 mm, max. load 20 kg, in a carton			
		SYS-AZ	30,60 36,72	<b>500692</b>
	qty. in pack 5 piece(s)	SYS-AZ-Set	144,40 173,28	<b>500767</b>
Means of transport for SYSTAINER		Type	RRP in £*	Order no.
	<b>SYS-Cart</b> for easy transportation of SYSTAINER sizes 1-5 and SORTAINERS., 4 steering rollers, 2 of which can be locked, robust handles, base area 360x520 mm, load capacity 100 kg, roller Ø 100 mm, weight 2,8 kg, in a carton	RB-SYS	64,80 77,76	<b>495020</b>
	<b>SYS roller</b> transportation of SYS Classic and SYS T-LOC, extra large wheels (D 200 mm) for easy transportation up and down steps, rotating lockable front rollers – manoeuvre in all directions, incl. safety belt, carrying power 100 kg, carrying power 5 kg, front roller Ø 75 mm, rear roller Ø 200 mm, Dimensions (L x W x H) 440 x 600 x 1100 mm, weight 6,5 kg, in a carton	SYS-Roll 100	121,00 145,20	<b>498660</b>
SYSTAINER T-LOC with inlays for abrasives		Type	RRP in £*	Order no.
	<b>SYSTAINER T-LOC</b>			
	with insert for abrasive Ø 115 mm, number of compartments 5, systainer size SYS 1 T-LOC	SYS-STF D115	45,05 54,06	<b>497683</b>
	with insert for abrasives Ø 125 mm, number of compartments 5, systainer size SYS 1 T-LOC	SYS-STF D125	45,05 54,06	<b>497685</b>
	with insert for abrasives 80x133 mm, number of compartments 6, systainer size SYS 1 T-LOC	SYS-STF 80x133	45,05 54,06	<b>497684</b>
	with insert for abrasives STF Delta 100x150, number of compartments 5, systainer size SYS 1 T-LOC	SYS-STF Delta 100x150	45,05 54,06	<b>497686</b>
	with insert for Ø 90 mm abrasives and 93V abrasives, number of compartments 8, systainer size SYS 1 T-LOC	SYS-STF-D77/D90/93V	44,55 53,46	<b>497687</b>
	with insert for abrasives 115x228mm, number of compartments 6, systainer size SYS 2 T-LOC	SYS-STF 115x228	48,90 58,68	<b>497688</b>
	with insert for abrasives 93x178mm, number of compartments 6, systainer size SYS 2 T-LOC	SYS-STF 93x178/93V	48,90 58,68	<b>497689</b>
	with insert for abrasives Ø 150 mm, number of compartments 10, systainer size SYS 3 T-LOC	SYS-STF D150	52,60 63,12	<b>497690</b>
	with insert for abrasive, dia. 225 mm, number of compartments 3, systainer size SYS 4 T-LOC	SYS-STF D225	56,10 67,32	<b>497691</b>
	with insert for abrasives Ø 150 mm, for grits P80, P180, P280, P400 and P500 according to the Festool "4-step sanding" system, systainer size SYS 3 T-LOC	SYS-STF D150 4S	56,20 67,44	<b>497821</b>

### SYSTAINER T-LOC / SYSTAINER SYS MAXI with inserts for Festool machines

	Type	RRP in €*	Order no.	
	<b>SYSTAINER T-LOC</b>			
	for cordless drills C 12/15 Li, systainer size SYS 1 T-LOC	SYS-C 12/15 Li	45,05 54,06	<b>498167</b>
	for CXS cordless drills, systainer size SYS 1 T-LOC	SYS-CXS	45,05 54,06	<b>498168</b>
	for LS 130, systainer size SYS 1 T-LOC	SYS-LS 130	45,05 54,06	<b>497664</b>
	for RS 400, RTS 400, systainer size SYS 1 T-LOC	SYS-RS/RTS 400	45,05 54,06	<b>497663</b>
	for cordless drills in the T-series, systainer size SYS 1 T-LOC	SYS-T+3	45,05 54,06	<b>497667</b>
	for DS 400, DTS 400, systainer size SYS 2 T-LOC	SYS-DS/DTS 400	48,90 58,68	<b>497676</b>
	for DX 93, systainer size SYS 2 T-LOC	SYS-DX	45,05 54,06	<b>497670</b>
	for ES 125, ETS 125, systainer size SYS 2 T-LOC	SYS-ETS 125/ES 125	48,90 58,68	<b>497674</b>
	for OFK 500, systainer size SYS 2 T-LOC	SYS-OFK 500	48,90 58,68	<b>497675</b>
	for RAS 115, systainer size SYS 2 T-LOC	SYS-RAS 115	48,90 58,68	<b>497672</b>
	for RO 150 E, WTS 150, systainer size SYS 2 T-LOC	SYS-RO 150 E/WTS 150	49,90 59,88	<b>497662</b>
	for RS 100, RS 1, systainer size SYS 2 T-LOC	SYS-RS 100/RS 1	48,90 58,68	<b>497668</b>
	for RS 200, RS 2, systainer size SYS 2 T-LOC	SYS-RS 200/RS 2	48,90 58,68	<b>497671</b>
	for RS 300, RS 3, systainer size SYS 2 T-LOC	SYS-RS 300/RS 3	48,90 58,68	<b>497669</b>
		for ES 150, ETS 150, systainer size SYS 3 T-LOC	SYS-ETS/ES 150	52,60 63,12
	for HL 850, systainer size SYS 3 T-LOC	SYS-HL	52,60 63,12	<b>497679</b>
	for OF 1010 and putty router KF, systainer size SYS 3 T-LOC	SYS-OF 1010/KF	52,60 63,12	<b>497678</b>
	for RO 150 FEQ, systainer size SYS 3 T-LOC	SYS-RO 150 FEQ	52,60 63,12	<b>497680</b>
	for TPE-RS 100, systainer size SYS 3 T-LOC	SYS-TPE	52,60 63,12	<b>497677</b>
		for PF 1200, ATF, AP 55, systainer size SYS 4 T-LOC	SYS-PF 1200/ATF/AP 55	56,35 67,62
	for TS 55, TS 55 R, systainer size SYS 4 T-LOC	SYS-TS 55	56,35 67,62	<b>497681</b>
		for TS 75, systainer size SYS 5 T-LOC	SYS-TS 75	70,00 84,00
	for BS 75, systainer size SYS MAXI	SYS-BS 75	79,60 95,52	<b>490751</b>
	for BS 105, systainer size SYS MAXI	SYS-BS 105	79,60 95,52	<b>490752</b>

## Workplace organisation

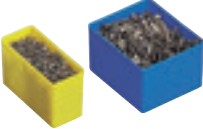
### System accessories

<b>SYSTAINER with universal insert</b>		Type	RRP in £*	Order no.
	<b>SYSTAINER T-LOC</b>			
	with universal insert for sundries, systainer size SYS 1 T-LOC	SYS 1 UNI	45,05 54,06	<b>497692</b>
	with single diced foam insert to produce an aperture of any desired shape, systainer size SYS 1 T-LOC	SYS 1 VARI	48,45 58,14	<b>497693</b>
	with double diced foam insert to produce an aperture of any desired shape, systainer size SYS 2 T-LOC	SYS 2 VARI	52,30 62,76	<b>497696</b>
	with foam insert, for safe storage of cutters D 8, D 12, in a SYSTAINER SYS 1 T-LOC	SYS-OF D8/D12	58,80 70,56	<b>497695</b>
	with individual removable plastic containers, plastic container, no content, systainer size SYS 1 T-LOC	SYS 1 BOX	58,80 70,56	<b>497694</b>
<b>Plastic containers and inserts for SYS-StorageBox and SYS 1 BOX</b>				
	<b>Plastic containers</b>			
	for SYS-Storage Box SYS-SB, qty. in pack: 6, Dimensions [L x W x H] 60 x 60 x 71 mm, qty. in pack 6 piece(s)	Box 60x60x71/6 SYS-SB	8,15 9,78	<b>500066</b>
	for SYS-Storage Box SYS-SB, qty. in pack: 4, Dimensions [L x W x H] 60 x 120 x 71 mm, qty. in pack 4 piece(s)	Box 60x120x71/4 SYS-SB	9,45 11,34	<b>500067</b>
	for SYS-Storage Box SYS-SB, qty. in pack: 2, Dimensions [L x W x H] 180 x 120 x 71 mm, qty. in pack 2 piece(s)	Box 180x120x71/2 SYS-SB	10,35 12,42	<b>500068</b>
	for SYS 1 T-LOC box, red, Dimensions [L x W x H] 49 x 49 x 71 mm, qty. in pack 12 piece(s), in a carton	Box 49x49/12 SYS1 TL	9,95 11,94	<b>498038</b>
	for SYS 1 T-LOC box, yellow, Dimensions [L x W x H] 49 x 98 x 71 mm, qty. in pack 6 piece(s), in a carton	Box 49x98/6 SYS1 TL	7,70 9,24	<b>498039</b>
	for SYS 1 T-LOC box, blue, Dimensions [L x W x H] 98 x 98 x 71 mm, qty. in pack 3 piece(s), in a carton	Box 98x98/3 SYS1 TL	6,50 7,80	<b>498040</b>
	for SYS 1 T-LOC box, green, Dimensions [L x W x H] 98 x 147 x 71 mm, qty. in pack 2 piece(s), in a carton	Box 98x147/2 SYS1 TL	8,35 10,02	<b>498041</b>
	for SYS 1 T-LOC box, orange, Dimensions [L x W x H] 49 x 245 x 71 mm, qty. in pack 2 piece(s), in a carton	Box 49x245/2 SYS1 TL	8,35 10,02	<b>498042</b>
	<b>Deep-drawer insert</b>			
	for SYS 1 T-LOC box, insert for fixing and positioning boxes, in a carton	Box TZE-SYS 1 TL	5,55 6,66	<b>498043</b>

### SYSTAINER T-LOC with insert for hand tools



#### SYSTAINER T-LOC

the required tool can be found quickly since all hand tools are clearly displayed for the joiner, items included without tools, wooden insert, installation recommendations, systainer size SYS 4 T-LOC

Type	RRP in £*	Order no.
SYS-HWZ	117,15 140,58	497658

### SYSTAINER T-LOC SYS-MFT



#### SYSTAINER T-LOC

1x cover for label field, can be connected to the entire Systainer range (except SYS-MINI), simple, compact transportation, cover with MDF board for clamping and fixing workpieces, Dimensions [L x W x H] 396 x 296 x 105 mm, dimensions with floor stand [L x W x H] 396 x 296 x 112 mm, inner dimensions [L x W x H] 383 x 273 x 75 mm, weight 2,0 kg

Type	RRP in £*	Order no.
SYS-MFT	53,75 64,50	500076

### Hole drilling set



#### Hole drilling set

for OF 900, OF 1000, OF 1010, OF 1400, for use with hole line guide rails, guide plate, centring mandrel, operation tool, hinge location cutter HM Ø 35 mm, dowel drill HW Ø 5 mm (V-shaped tip), dowel drill HM Ø 5 mm (with centring bit and pre-cutter), 2 parallel side fences with adjustable stop, 2 clamps FSZ 120, 2 longitudinal stops, in a SYSTAINER SYS 1 T-LOC

Type	RRP in £*	Order no.
LR 32-SYS	338,90 406,68	584100

### Foam inserts for SYSTAINER

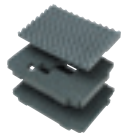

#### Foam insert

for SYS 1-5 T-LOC, dimpled insert (for lid), base insert and diced insert, qty. in pack 3 piece(s)

Type	RRP in £*	Order no.
SYS-VARI SE TL	15,95 19,14	497877

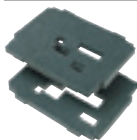

#### Diced foam insert set

for SYS 1-5 T-LOC, diced sections can be pushed out to produce any desired aperture, qty. in pack 2 piece(s)

Type	RRP in £*	Order no.
SYS-VARI RM TL	12,60 15,12	497878

### Lids and bottoms for Systainers

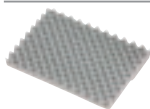

#### Cover pad

for SYS 1-5 T-LOC, with knobs, Dimensions [L x W x H] 355 x 245 x 30 mm

Type	RRP in £*	Order no.
SE-DP SYS 1-5 TL	4,50 5,40	498044

for SYS MAXI, with knobs, Dimensions [L x W x H] 560 x 340 x 30 mm

Type	RRP in £*	Order no.
SE-DP SYS-MAXI	12,30 14,76	491633

for SYS MIDI 3 TL, Dimensions [L x W x H] 472 x 247 x 30 mm

Type	RRP in £*	Order no.
SE-DP SYS-MIDI	11,35 13,62	499617

for SYS MINI, with knobs

Type	RRP in £*	Order no.
SE-DP SYS-MINI	3,95 4,74	491638

for SYS MINI TL, Dimensions [L x W x H] 247 x 134 x 15 mm

Type	RRP in £*	Order no.
SE-DP SYS-MINI TL	4,75 5,70	499619



#### Base pad

for SYS 1-5 T-LOC, protects the content

Type	RRP in £*	Order no.
SE-BP SYS 1-5 TL	4,95 5,94	498045

for SYS MAXI

Type	RRP in £*	Order no.
SE-BP SYS-MAXI	8,40 10,08	491632



for SYS MIDI 3 TL, Dimensions [L x W x H] 480 x 278 x 30 mm

Type	RRP in £*	Order no.
SE-BP SYS-MIDI	9,45 11,34	499618

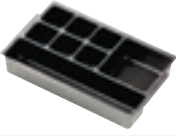
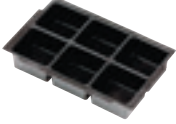
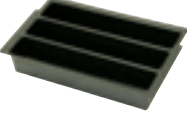

## Workplace organisation

### System accessories









#### Inlays and inserts for SYSTAINER

		Type	RRP in £*	Order no.
	<b>Multi-purpose insert</b>			
	for SYS MINI	TZE-UNI SYS-MINI	4,70 5,64	<b>491634</b>
	for SYS MINI TL, Dimensions [L x W x H] 258 x 163 x 45 mm	TZE-UNI SYS MINI TL	6,45 7,74	<b>499620</b>
	<b>Deep-drawer insert</b>			
	for SYS MINI			
	with 6 dispositions, dimensions 72 x 68 x 40 mm	TZE-6 SYS-MINI	4,70 5,64	<b>491635</b>
	with 5 dispositions, dimensions 140 x 40 x 40 mm	TZE-5 SYS-MINI	4,70 5,64	<b>491636</b>
	with 3 dispositions, dimensions 230 x 42 x 40 mm	TZE-3 SYS-MINI	4,55 5,46	<b>491637</b>
	<b>Cartridge inlay</b>			
	for SYS 5 T-LOC, to store cartridges, Height 130 mm, in a carton	TZE-KT SYS 5 TL	15,75 18,90	<b>497876</b>

#### Other accessories

		Type	RRP in £*	Order no.
	<b>Additional hand grip</b>			
	for carrying SYS 1 T-LOC and SYS 2 T-LOC upright	ZSG -Sys 1/2 TL / 1	13,90 16,68	<b>497856</b>
	<b>Cover</b>			
	cover for labelling panels SYS T-LOC, protects the labelling panels on the SYSTAINER T-LOC from damage and moisture, qty. in pack 10 piece(s)	AB-BF SYS TL 55x85mm /10	3,45 4,14	<b>497855</b>

Plug-It accessories

		Type	RRP in £*	Order no.
	<b>Suction hose plug it D 27 antistatic</b> with plug it-connection, antistatic, Diameter 27 mm, Length 3,5 m, in a carton	plug it D 27x3,5m-AS	- - - -	<b>456746</b>
	<b>plug it-cable</b>			
	rubber insulated cable 240V plug it, Length 4 m	H05 RN-F/4	19,60 23,52	<b>490650</b>
	rubber insulated cable 240V plug it, Length 4 m, qty. in pack 3 piece(s)	H05 RN-F/4 3x	- - -	<b>499851</b>
	for long-reach sander PLANEX, particularly suitable for use with the PLANEX LHS 225 thanks to extended cable bushing, for example for sanding work in dry construction, rubber insulated cable 240V plug it, Length 4 m	H05 RN-F/4 EU PLANEX	16,95 20,34	<b>499819</b>
	rubber insulated cable 240V plug it, Length 7,5 m	H05 RN-F/7,5	- - -	<b>489661</b>
	rubber insulated cable 240V plug it, Length 10 m	H05 RN-F 2x1,0/10	24,80 29,76	<b>500636</b>
	green rubber-insulated cable, Length 4 m	H05 BQ-F/4	22,45 26,94	<b>489662</b>
	green rubber-insulated cable, Length 7,5 m	H05 BQ-F/7,5	29,50 35,40	<b>489663</b>
	<b>plug it conversion-kit</b>			
	For RS1, RS 1 C, DX 93, RO 150/R02, RAS 115, BF 1, PS 200/PS/2, KF 4, Length 360 mm	UBS-PUR 360 plug it 240 V	15,20 18,24	<b>491144</b>
	For RS 2, RS 3, RS 400/RS 4, DS 400, ES 125, OF 1000, OF 900, ATF 55, AT 65, AP 55, AP 65, EHL 65, Length 420 mm	UBS-PUR 420 plug it 240 V	15,20 18,24	<b>491145</b>

Like working with Festool electric power tools?  
Then you will definitely like our select Festool fan products.

# LEISURE



### Training top

#### Sports top in jersey style.

Breathable, quick-drying and anti-odour item suitable for every type of sport. Zip at neck for even more comfort. Fashionable look with green collar and green and blue contrasting-colour stripes on sleeve and along the side. Festool print on the chest.  
Material: 100% Polyester.

Sizes	Order no.	RRP in £
S	<b>498447</b>	28,35
M	<b>498448</b>	28,35
L	<b>498449</b>	28,35
XL	<b>498450</b>	28,35



### Golf cap

#### Sports cap with embroidered Festool logo.

Curved visor with green stripes. Width adjustment at back for optimal fit.  
Material: Denim.

Size	Order no.	RRP in £
One size	<b>497899</b>	7,35

### Softshell jacket

#### Breathable, windproof and waterproof softshell jacket with microfleece on the inside and two-way zip for ultimate comfort.

Two hip pockets and one chest pocket, all have zips. Size and range of vision of detachable hood are individually adjustable. Trendy details include the green decorative stitching, the green Festool logo on the left upper arm and the silver-coloured decorative print on the sleeve and back.  
Inner material: 93% Polyester, 7% Spantex.  
Outer material: 100% Polyester-Microfleece, anti-pilling.

Sizes	Order no.	RRP in £
M	<b>498477</b>	62,40
L	<b>498478</b>	62,40
XL	<b>498479</b>	62,40
XXL	<b>498480</b>	62,40



More products from our current collection can be found on:

[www.festool.co.uk](http://www.festool.co.uk)



# BODYSHOP



**uvex**

## Safety goggles

Original UVEX safety goggles uvex i-vo.

Duo-Component Technology for outstanding working comfort: Soft components around sensitive areas (nose, forehead, ear) prevent pressure marks.

Size	Order no.	RRP in £
One size	<b>500119</b>	14,30



## Yardstick

Quality standard from Adga.

Inner precision fields made from hardened steel for wear-free and continuous suspension. The joint always remains smooth and can be accurately stopped. With Festool logo.

Measuring length	Order no.	RRP in £
2 m	<b>497901</b>	4,55

## Toolie

Practical hexagon spherical head tool for almost every screwing situation

There are nine hexagon socket wrenches with MagicRing in the sturdy and ergonomically designed housing, which can be selected and folded out simply using an eject button.



Size	Order no.	RRP in £
12 cm long	<b>498863</b>	18,75



## Tape measure

Practical 3-metre tape measure which displays measurement in cm and inches.

Fold-out compass to mark a circle. Dark blue with printed Festool logo.

Measuring length	Order no.	RRP in £
3 m	<b>495415</b>	8,85

## Notebook

Large hardcover notebook with 200 pages.

This practical hardback notebook offers lots of space on 200 chequered pages for notes, thoughts and ideas.

Size	Order no.	RRP in £
DIN A4	<b>498866</b>	10,90



## Thermal cup

Vacuum thermal cup with matt stainless steel finish.

Double-walled, thermo-insulated lid with sealable opening. Capacity: 0.3 l. Lasered Festool logo.

Dimensions	Order no.	RRP in £
Height: 17 cm	<b>500326</b>	11,40



# OFFICE

- A**
- Abrasive paper holder ..... 369
  - Abrasive system ..... 65
  - Abrasives ..... 107
    - Brilliant 2 ..... 108, 110-112, 115, 117-121, 123
    - Diamant ..... 108-109, 113, 115
    - Granat ..... 108-110, 112, 114, 116-121, 123
    - Platin 2 ..... 108-110, 113, 115
    - Rubin 2 ..... 108-112, 114, 116-117, 119-122
    - Saphir ..... 108, 111, 113, 115-117, 122
    - Titan 2 ..... 108-109, 113, 115-116, 118, 124
    - Vlies ..... 108, 113, 115, 118
  - Accessories Systemer
    - SYS ZH-SYS-PS 420 ..... 30
  - Adapter
    - MX 1000, MX 1000/2, MX 1200, MX 1200/2,  
MX 1600/2, MX 1600/2 DUO ..... 311
  - Adapter AD
    - BHC 18, RHP 18, CHP 18 ..... 215
    - DRC 18/4, PDC 18/4, DR 18/4, PD 20/4,  
DRP 16, DRP 18, PDP 20-4 ..... 216
  - Adapter DOSH ..... 370
  - Adapter plate
    - AP-KA 65 ..... 256
  - Adapter table
    - ADT-PS 420 ..... 30, 371
  - Adapter VAC SYS ..... 367, 368
  - Additional hand grip
    - LHS 225 ..... 330
  - Additional roller ..... 260-261
  - Additional side-mounted hand grip
    - DRC 18/4, PDC 18/4, BHC 18 ..... 215
  - Additional stop
    - DF 500 ..... 247
    - ZA-SYM 70 E ..... 33
  - Adhesive
    - KA 65 ..... 260
  - Adhesive cushion strip
    - FS, FS/2 ..... 370
  - Aluminium composite milling
    - machine ..... 153, 163
  - Aluminium cutter ..... 179
  - Angle adapter
    - DR 20, DRP 20 ..... 216
  - Angle attachment
    - C 12, C 15, T 12+3, T 15+3, T 18+3 ..... 214
    - CXS ..... 215
    - DRC 18/4, PDC 18/4, DR 18/4, PD 20/4,  
DRP 16, DRP 18, PDP 20-4 ..... 216
  - Angle stop
    - WA ..... 34, 35, 196, 343, 370
  - Angle table
    - WT-PS 420 ..... 30
  - Anti-static suction hose ..... 283-284
  - AP-KA 65 ..... 256
  - APS ..... 145, 159
  - ASA ..... 356, 369
  - AUTOCLEAN ..... 267
- B**
- Balancer
    - RG 150 ..... 327
  - Baluster bit ..... 225
  - Base pad
    - SYSTEMER ..... 379
- C**
- Base runner
    - LA-OF 1400 ..... 157
    - LA-OF 2200 ..... 158
    - LAS-HGW-PS 420 ..... 30
    - LAS-PS 420 ..... 30
    - LAS-Soft-PS 420 ..... 30
    - LAS-STF-PS 420 ..... 30
    - LAS-St-PS 420 ..... 30
  - Battery ..... 211
  - Battery pack
    - BPC 15 5.2 Ah li-ion ..... 30, 31, 214
    - BPC 18 5.2 Ah li-ion ..... 30-31, 214, 215-216, 217
    - BP-XS ..... 215
  - Beam planer
    - PL 205 ..... 338, 344
    - PL 245 ..... 338, 344
  - Beechwood dowel ..... 246
  - Belt sander
    - BS 105 ..... 75, 101
    - BS 75 ..... 75, 101
  - Belt sander module
    - CMS-BS ..... 76
  - Bench saw module
    - CMS-TS 55 R ..... 19, 349
    - CMS-TS 75 ..... 19
  - Bench-mounted router
    - TF 1400, TF 2200 ..... 143
  - Bevel
    - SM-KS 120 ..... 32
  - BHC 18 ..... 206, 215, 235
  - Bi-metal saw blade, metal
    - MSB ..... 47
  - Bi-metal universal saw blade
    - USB ..... 47
  - Bit holder
    - Bit box ..... 219
    - Bit cassette ..... 220
    - DWC 18 ..... 217
  - Bits
    - 100 mm bits ..... 219
    - for DWC ..... 217
    - ImpactPlus bits ..... 218
    - Standard bits ..... 218
  - Blade
    - SSU 200, IS 330 ..... 342
  - BMS 180 ..... 89, 106
  - Boom arm
    - ASA ..... 290, 356, 369
  - BPC 15 5.2 Ah li-ion ..... 30
  - BPC 18 5.2 Ah li-ion ..... 30
  - Brilliant 2 ..... 108, 110-112, 115, 117-121, 123
  - Brush machine
    - RUSTOFIX BMS 180 ..... 89
  - Brush ring
    - DSG-AG 125 ..... 329
    - RG 130 ..... 328
    - RG 150 ..... 327
  - Brush segment
    - LHS 225 ..... 330
  - Brush strip
    - RAS 115, RAS 180 ..... 100
  - BS 105 ..... 75, 101
  - BS 75 ..... 75, 101
- C**
- C 15 ..... 204, 214
  - Carbide-tipped disc
    - RG 80 ..... 326
  - Carpentry drill stands ..... 225
  - Carpentry portable circular saw
    - HK 132 ..... 337, 343
  - Carpet nozzle ..... 289
  - Carpet remover
    - TPE-RS 100 ..... 322, 331
  - Carpet remover blade ..... 331
  - Carrying harness
    - LHS 225 ..... 330
  - CARVEX
    - PS 420 ..... 13
    - PSB 420 ..... 13
    - PSBC 420 ..... 14, 232
    - PSC 420 ..... 14, 232
  - Ceiling suspension EAA ..... 369
  - Centering bit ..... 224
  - Centring mandrel
    - OF 900, OF 1000, OF 1010, OF 1400,  
OF 2200 ..... 156
  - CENTROTEC ..... 202, 214-216, 220-221, 223-224
  - Chain cutters
    - CM 150 ..... 345
  - Chain lubrication oil ..... 342
  - Chain mortiser
    - CM 150 ..... 339, 345
  - Chainsaw chain
    - SSU 200, IS 330 ..... 342
  - Chamfer cutter ..... 169
  - Charger
    - TLC 3 ..... 30, 31, 214-217
  - Charging system ..... 211
  - Chip collection bag
    - EHL 65, HL 850 ..... 196
  - Chip deflector
    - OF 1400 ..... 157
    - OF 2200 ..... 158
    - OF 900, OF 1000, OF 1010 ..... 156
  - Circle cutter
    - KS-PS 420 ..... 30
    - KS-PS/PSB 300 ..... 30
  - Circular brush RB
    - RAS 115, RAP 80 ..... 100
  - Circular saw blade, wood
    - HSB 100/HCS ..... 47
  - Circular saw blades ..... 42
  - Clamp
    - KL-KS ..... 32
  - Clamping kit
    - SZ-KS ..... 32
  - Clamping nut SM
    - RAS 115, RAP 80 ..... 100
  - Cleaning cloth ..... 126, 133
  - Cleaning sets ..... 282
  - CLEANTEC
    - Anti-static suction hose ..... 283-284
    - Cleaning sets ..... 282
    - CT 17 ..... 268
    - CT 26 AC/CT 36 AC/CT 48 AC ..... 273
    - CT 26/CT 36 ..... 271
    - CT 36 AC HD ..... 275
    - CT 36 AC PLANEX ..... 274
    - CT 48 ..... 272
    - CT 48 EC ..... 276
    - CT 48 EC/B22 ..... 277
    - CTH 26/CTH 48 ..... 278
    - CTL MIDI ..... 270
    - CTL MINI ..... 269
    - Filters and filter bags ..... 291-293
    - Hose sleeves ..... 286-287
    - Suction hose ..... 285
  - CM 150 ..... 339, 345

CMS	348-349, 366
CMS and Basis module tower MT 600	
CMS	101
CMS TS 55 R	19, 348
CMS TS 75	19, 348
CMS-BS	76, 101, 348
CMS-OF	142, 348
CMS-PS	15, 348
Collet	
MFK 700, OFK 700, OF 900, OF 1000,	
OF 1010, KF	156
OF 1400, OF 2000, OF 2200	157, 158
OFK 700, MFK 700, OF 900, OF 1000,	
OF 1010	162
Combination bevel	
FS/2	370
Combination suction hose	289
Compact Module System	348-349, 366
Compound mitre saw	
SYMMETRIC SYM 70	22
Compressed air	297
Compressed air eccentric sander	
LEX 2 185/7	81, 102
LEX 3 125	79, 102
LEX 3 150	80, 102
LEX 3 77	78, 102
Compressed air orbital sander	
LRS 400	83, 104
LRS 93	82, 104
Connector	163, 367, 371
CONTURO	
KA 65	254, 260
Conversion kit	
TC 3000	373
Copier scanning set	
OF 900, OF 1000, OF 1010, KF	161
Copying ring	
OF 1400	157
OF 2200	158
OF 900, OF 1000, OF 1010, KF	156
Cordless drills	
C 15	204, 214
CXS	203, 215
QUADRIVE DRC 18/4	207, 216, 236
T 15+3	124
T 15+3, T 18+3	205, 214, 234
Cordless drywall screwdriver	
DURADRIVE DWC 18	210, 217, 237
Cordless hammer drill	
BHC 18	206, 215, 235
Cordless impact drill	
QUADRIVE PDC 18/4	207, 216, 236
Cordless pendulum jigsaws	
CARVEX PSC, CARVEX PSBC 420	14, 232
Cordless plunge-cut saw	
TSC 55	17, 233
Counterprofile cutters	177
Cover	
ABSA-TS 55	31
Cover pad	
SYSTEMER	379
Cross brace	
MFT 3	367
Cross stop	
DF 500, DF 700	247, 249
Crown stop	
AB-KS	32

CS 50	24, 34
CS 70	25, 35
CT 17	268
CT 26 AC/CT 36 AC/CT 48 AC	273
CT 26/CT 36	271
CT 36 AC HD	275
CT 36 AC PLANEX	274
CT 48	272
CT 48 EC	276
CT 48 EC/B22	277
CT accessories	296-297
Compressed air	297
CT Wings	296, 355
CTH 26/CTH 48	278
CTL MIDI	270
CTL MINI	269
Cup brush, TB	
RAS 115, RAP 80	100
Curve saw blade	40
Cutter D	
DOMINO DF 500	246
Cutter spindle	
CMS-OF	366
Cutter tools for OFK 500	182
Cutter tools for OFK 700 and	
MFK 700	180-181
Cutter tools for putty router KF 5	183
Cutter V groove	179
Cutter wheel	
RG 150	327
RG 80	326
Cutters Accessories	155-187
Cutters Overview Products and	
Applications	136-137
CXS	203, 215

## D

Deburring countersink	224
Deflector	
FS	371
Delta sander	
DTS 400	70
DELTEX	
DX 93	71, 98
deNibber	127
Depth stop	
OS-TA-Set	46
Depth stop DC UNI FF	
DRC 18/4, PDC 18/4, DR 18/4, PD 20/4,	
DRP 16, DRP 18, PDP 20-4	216
Depth stop FastFix	214
DF 500	242, 246-247
DF 700	243, 248-249
Diamant	108-109, 113, 115
Diamond disc	
DSG-AG 125	329
RG 130	328
RG 150	327
RG 80	326
Diamond grinders	
RENOFIX RG 130	319, 328
Diamond grinding system	
DSG-AG 125	320, 329
Disk groove cutter	175
Disposal bag	279, 292

DOMINO	
Beechwood	248
Cutter	248
DF 500	242, 246-247
DF 700	243, 248-249
Dowel pin, beechwood	246, 248
Dowel pin, sipo	246, 248
Jointing System Accessories	244-249
Jointing System Overview Products	
and Applications	240
DOMINO joining machine	
DOMINO DF 500	242, 246-247
DOMINO XL DF 700	243, 248-249
DOMINO joining system	241
Double-layered safety filter bag	279
Dovetail cutters	173
Dovetail joint template	
OF 1010, OF 1400	160
Dowel drill	160
Dowel/Through-hole drill	176
DR 18/4	208, 216
DR 20	209, 216
DRC 18/4	207, 216, 236
Drill	
QUADRILL DR 18/4	208, 216
QUADRILL DR 20	209, 216
Drill bit	221
Drill bit with depth stop	224
Drill countersink with depth stop	224
Drilling and Fastening Accessories	212-225
Drilling and Fastening Overview	
Products and Applications	200-201
Drilling cutter	172
Drilling dust nozzle	
BHC 18, PDC 18, PD 20, CT, CTL, CTM	215
Drywall screwdriver	210, 217
Drywall screws	225
Drywalling	312-331
DSG-AG 125, DSC-AG 125,	
DSC-AG 230	320, 329
DTS 400	70, 98
DUPLEX LS 130	72, 99
DURADRIVE DWC 18	210, 217, 237
Dust bag	
BS 75, BS 105	101
SB-TSC	31
Dust classes	266
Dust extraction	266
DWC 18	210, 217, 237
DX 93	71, 98

## E

EAA	357, 369
Eccentric sander	
ETS 125	61
ETS 150	62
ETS EC 150	63
WTS 150	64
EC-TEC motor	23, 202
Edge bander	
CONTURO KA 65	254, 260
Edge finish	260
Edge processing system	
OF-FH 2200	148, 161
Edge trimming chamfer cutter	172
Edge trimming cutter	171

- Edging Accessories ..... 258-261  
 Edging Overview Products  
   and Applications ..... 252  
 EHL 65 EQ ..... 192, 196  
 Energy box EAA CT/SR ..... 357, 369  
 ErgoFix ..... 302  
 ErgoFix adapter ..... 311  
 ETS 125 ..... 61, 95, 124  
 ETS 150 ..... 62, 96  
 ETS EC 150 ..... 63  
 Extension  
   FS/2 ..... 371  
   MFT 3 ..... 367  
 Extension handle ..... 331  
 Extension profile MFS  
   MFS 400, MFS 700 ..... 159  
 Extension table  
   CMS-GE ..... 366  
   CS 70 VB ..... 35  
   OF 900, OF 1000, OF 1010, KF ..... 156  
   CS 70 VL ..... 35  
   VL ..... 34, 366  
 Extraction Accessories  
   and Consumables ..... 280-297  
 Extraction adapter  
   BS 75, BS 105 ..... 101  
   HL 850 ..... 196  
 Extraction and workplace system ..... 65  
 Extraction hood  
   DSG-AG 125 ..... 329  
   OF 1400, OF 2000, OF 2200 ..... 157, 158  
   OF 900, OF 1000, OF 1010, KF ..... 156  
 Extraction Overview Products  
   and Applications ..... 264-265  
 Extraction ring ..... 141  
 Extractor set  
   CS 70 AB ..... 34, 35, 366
- F**
- Facing cutter ..... 178  
 Fastening clamp  
   for MFT ..... 163, 367, 370  
 FastFix ..... 141, 214  
 FastFix eccentric attachment ..... 214  
 FastFix louver pad  
   RO 125 ..... 93  
 FastFix polishing pad PT-STF  
   RO 125, RO 150 ..... 93, 94  
   RO 90 DX ..... 92  
 FastFix sanding pad ST-STF  
   RO 125, RO 150 ..... 93, 94  
   RO 90 DX ..... 92  
 Feather key  
   WCR 1000, UCR 1000 ..... 372  
 Feeler roller for disc cutter ..... 163  
 Filter ..... 291-293  
   Filter elements ..... 291  
   Wet filter ..... 291  
 Filter bags ..... 279, 291-293  
   Disposal bag ..... 292  
   SELFCLEAN ..... 292  
 Fine adjuster for guide stop  
   OF 900, OF 1000, OF 1010, KF ..... 156  
 Fine adjuster for parallel side fence  
   OF 900, OF 1000, OF 1010, KF ..... 156, 163  
 Fine tooth saw blade ..... 42  
 Fine-cut saw blade ..... 38  
 Finish Cleaner ..... 124, 126  
 Fixed clamps ..... 367
- Flat sanding pad SSH-STF-LS130  
   LS 130 ..... 99  
 Flat tooth saw blade ..... 44  
 Flexible sanding pad ST-D115 ..... 100  
 Floor guide  
   RG 150 ..... 327  
 Floor nozzles ..... 288  
 Flute cutters ..... 170  
 Flute profile sanding pad  
   LS 130 ..... 99  
 Foam inserts  
   SYSTEMER ..... 379  
 Foldaway legs  
   CS 50 KB ..... 34  
 Foot valve VAC SYS ..... 368  
 Forstner drill bit ..... 223  
 FS 1400/2 ..... 161  
 FS 2424/2 ..... 161  
 FS/2 ..... 352-353, 370
- G**
- Geared chuck  
   DR 20, DRP 20 ..... 216  
 Geared eccentric sander  
   ROTEX RO 125 ..... 59, 93, 124  
   ROTEX RO 150 ..... 60, 94, 124  
   ROTEX RO 90 DX ..... 58, 92, 124  
 GECKO ..... 163, 354  
 GECKO dual suction pad ..... 163, 354  
 Granat ..... 108-110, 112, 114, 116-121, 123, 160  
 Groove cutter ..... 159, 165-166  
 Guard ..... 366  
 Guide ..... 23  
 Guide control black powder ..... 103  
 Guide frame ..... 345  
 Guide plate  
   OF 900, OF 1000, OF 1010, OF 1400 ..... 161  
 Guide rail ..... 352, 141, 163, 370  
   FS 1400/2 ..... 161  
   FS 2424/2 ..... 161  
   FS/2 ..... 352-353, 370  
   HK 132, CSP 85/60, CSP 132, CSP 165,  
   CCP 380, NRP 90 ..... 343  
 Guide rail adapter  
   FS-PS/PSB 300 ..... 30, 371  
   OF 1400 ..... 157  
   OF 2200 ..... 158  
 Guide system for drilling ..... 225  
 Guide table  
   RG 130 ..... 328
- H**
- Half-round cutters ..... 168  
 Hammer drill  
   BHC 18 ..... 222  
   QUADRILL PD 20/4 ..... 208  
 Hand abrasive Vlies ..... 123  
 Hand rail cutter ..... 179  
 Handle  
   CT 11/22/33/44/55, CT 26/36, CT 48 ..... 296  
 Handrail fence  
   DF 500, DF 700 ..... 247, 249  
 Hand-sanding block HSK ..... 106  
 Hard fibre base runner  
   OF 900, OF 1000, OF 1010, KF ..... 156  
 High gloss sealant ..... 124, 128  
 Hinge location cutter ..... 175
- HK 132 ..... 337, 343  
   Milling set ..... 337, 343  
   Planing set ..... 337, 343  
 HL 850 ..... 193, 196  
 Holder for spray gun  
   WCR 1000, UCR 1000 ..... 372  
 Hole drilling set  
   OF 900, OF 1000, OF 1010,  
   OF 1400 ..... 161, 379  
 Hole punch  
   RS 300, RS 3, LRS 93 ..... 104  
 Hole series system  
   LR 32 ..... 147, 161  
 Hook  
   WCR 1000, UCR 1000 ..... 372  
 Hook driver ..... 224  
 Hook for punched walls  
   WCR 1000, UCR 1000, MFH 1000 ..... 372  
 Hose garage ..... 296  
 Hose holder ..... 296, 373  
 Hose sleeves ..... 286-287  
 HSS saw blade, elbowed  
   SSB ..... 47  
 HSS steel drill ..... 221  
 HSS twist drill ..... 220
- I**
- IAS 3 hose  
   LEX 3, LEX 2, LRS ..... 105  
 IAS 3 system ..... 77  
   LEX 3 77, LEX 3 125, LEX 3 150,  
   LEX 2 185 ..... 103  
   LRS 93, LRS 400 ..... 104  
 Insert boxes and inlays  
   SYS storage box, SYS 1 BOX ..... 378  
 Inserts and inlays  
   SYSTEMER ..... 380  
 Insulating material saw blade ..... 40  
 Interface pad IP-STF  
   ETS 125 ..... 95  
   ETS 150, ETS EC 150, WTS 150 ..... 96  
   LEX 3 77, LEX 3 125, LEX 3 150,  
   LEX 2 185 ..... 102  
   LHS 225 ..... 330  
   LS 30 ..... 99  
   RO 125 ..... 93  
   RO 150 ..... 94  
   RO 90 DX ..... 92  
 IS 330 ..... 336, 342
- J**
- Jigsaw module ..... 221  
   CMS-PS ..... 15  
 Jointing system  
   VS 600 GE ..... 146, 160
- K**
- KA 65 ..... 254, 260  
 KAPEX KS 120 ..... 21, 32  
 KAPEX KS 88 ..... 20, 32  
 Key-hole cutter ..... 176  
 Keyless chuck ..... 214, 216  
   CXS ..... 215  
 KF 5 ..... 152, 163, 183  
 Kickback stop  
   FS-RSP ..... 31, 370

KP 65/2 ..... 255  
KS 120 ..... 21, 32  
KS 88 ..... 20, 32

**L**

Laminate trimmer  
OFK 500 ..... 149, 162  
OFK 700 ..... 150, 162  
Lever clamp  
MFT ..... 163, 367, 370  
LEX -2  
LEX 2 185/7 ..... 81, 102  
LEX -3 ..... 77  
LEX 3 125 ..... 79, 102  
LEX 3 150 ..... 80, 102  
LEX 3 77 ..... 78, 102  
LHS 225 ..... 321, 330  
Linear sander  
DUPLEX LS 130 ..... 72  
Longitudinal stop ..... 371  
BS 75, BS 105 ..... 101  
CS 50, CMS-GE ..... 366  
CS 70 LA ..... 35  
LA-CS 50/CMS ..... 34  
LR 32 ..... 161  
Longlife filter bag ..... 279, 293  
Long-reach sander  
PLANEX LHS 225 ..... 321, 330  
LR 32 ..... 147, 161  
LRS 400 ..... 83, 104  
LRS 93 ..... 82, 104  
LS 130 ..... 72, 99

**M**

Magazine attachment  
DWC, DWP ..... 217  
Manual sanding ..... 106  
Masonry drill  
MAXI-SYSTAINER ..... 374  
Metal saw blade ..... 40  
MFH 1000 ..... 359, 372  
MFK 700 ..... 151, 162, 180-181  
MFS ..... 144  
MFS 400 ..... 159  
MFS 700 ..... 159  
MFT ..... 350  
MFT 3 ..... 350, 367  
MFT/3 CONTURO ..... 257  
Microfibre cloth ..... 126  
MIDI-SYSTAINER T-LOC ..... 374  
Milling set ..... 343  
Mineral materials ..... 184-187  
MINI-SYSTAINER T-LOC ..... 374  
Mixing centre, stirrers ..... 311  
Mobile dust extractor  
CLEANTEC CT 17 ..... 268  
CLEANTEC CT 26 AC/CT 36 AC/  
CT 48 AC ..... 273  
CLEANTEC CT 26/CT 36 ..... 271  
CLEANTEC CT 36 AC HD ..... 275  
CLEANTEC CT 36 AC PLANEX ..... 274  
CLEANTEC CT 48 ..... 272  
CLEANTEC CT 48 EC ..... 276  
CLEANTEC CT 48 EC/B22 ..... 277  
CLEANTEC CTH 26/CTH 48 ..... 278  
CLEANTEC CTL MIDI ..... 270  
CLEANTEC CTL MINI ..... 269

Module edge router  
MFK 700 ..... 151, 162  
Module mounting  
CMS-OF ..... 142  
CMS-PS ..... 15  
CMS-TS ..... 19  
Modules  
CTL/CTM/CTH 26/36/48 ..... 290  
Multifunction stool  
MFH 1000 ..... 359, 372  
Multifunction table  
MFT 3 ..... 350, 367  
MFT KAPEX ..... 32  
MFT/3 CONTURO ..... 257  
Multi-profile cutter ..... 176  
MX 1000, MX 1000/2, MX 1200 ..... 303  
MX 1200/2, MX 1600/2 ..... 304  
MX 1600/2 DUO ..... 305

**N**

Natural oil ..... 133

**O**

OF 1010 ..... 138, 156, 159, 163  
OF 1400 ..... 139, 157, 159  
OF 2200 ..... 140, 158, 159  
OF-FH 2200 ..... 148, 161  
OFK 500 ..... 149, 162, 182  
OFK 700 ..... 150, 162, 180-181  
Oil application ..... 84  
Oil dispenser  
SURFIX OS ..... 88, 133  
Oil sponge ..... 133  
One-handed planer  
EHL 65 EQ ..... 192, 196  
ORBITAL SANDER  
RS 100 ..... 66, 97  
RS 200 ..... 67, 97  
RS 300 ..... 68, 97  
RTS 400 ..... 69  
OS 400 ..... 27, 46  
Oscillator  
VECTURO OS 400 ..... 27, 46  
Oscillators ..... 29  
Ovolo edge cutter ..... 168

**P**

Pad ..... 124  
Panther saw blade ..... 42  
Parallel stop  
FS/2 ..... 371  
HK 132 ..... 343  
PA-EHL, PA-HL ..... 196  
PA-PS/PSB 300 ..... 30  
PA-TS 55 ..... 31  
PA-TS 75 ..... 31  
SSU 200, IS 330 ..... 342  
PD 20/4 ..... 208, 216  
PDC 18/4 ..... 207, 216, 236  
Pendulum jigsaws ..... 29  
CARVEX PS 420 ..... 13, 30  
CARVEX PSB 420 ..... 13, 30  
CARVEX PSBC 420 ..... 14, 30  
CARVEX PSC 420 ..... 14, 30  
TRION PS 300 ..... 12, 30  
TRION PSB 300 ..... 12, 30  
Perfect edge ..... 253

PF 1200 ..... 153, 163  
PL 205 ..... 338, 344  
PL 245 ..... 338, 344  
Planer  
HL 850 ..... 193, 196  
PLANEX  
LHS 225 ..... 321, 330  
Planing Accessories ..... 194-197  
Planing head  
EHL 65, HL 850 ..... 196  
Planing Overview Products  
and Applications ..... 190  
Planing set ..... 343  
Plastic saw blade ..... 40  
Plate  
TP-STF-DX93 ..... 98  
Platin 2 ..... 108-110, 113, 115  
Plug-it accessories ..... 381  
Plug-it cable ..... 330  
Plunge-cut saw  
TS 55 R ..... 16, 31  
TS 75 ..... 18, 31  
TSC 55 ..... 17, 31  
Plunge-cut saws ..... 29  
Polishing ..... 124  
Polishing agent  
MPA 5000, MPA 6000, MPA 8000,  
MPA 9000, MPA 11000 ..... 124, 126, 128  
MPA 6000/1 ..... 260  
Polishing felt ..... 128-132  
HSK ..... 260  
Polishing fleece STF ..... 133  
Polishing pads ..... 124  
RAP 80, RAP 150, RAP 180 ..... 125  
Polishing sponge ..... 128  
PoliStick ..... 129-132  
POLLUX 180 ..... 87, 124-125  
Positioning aid  
OS-AH Set ..... 46  
PRECISIO CS 50 ..... 24, 34  
PRECISIO CS 70 ..... 24, 35  
Precision adjustable square  
SM-SYM 70 ..... 33  
Precutter ..... 343  
Profile cutter ..... 177  
Profile groove cutter ..... 178  
Profile tongue cutter ..... 178  
Protective edging  
KA 65 ..... 260-261  
Protector  
RO 125 ..... 93  
RO 150 ..... 94  
RO 90 DX ..... 92  
PS 300 ..... 12, 30  
PS 420 ..... 13, 30  
PSB 300 ..... 12, 30  
PSB 420 ..... 13, 30  
PSBC 420 ..... 14, 30, 232  
PSC 420 ..... 14, 30, 232  
Putty router  
KF 5 ..... 152, 163, 183

**Q**

QUADRILL  
DR 18/4 ..... 208, 216  
DR 20 ..... 209, 216  
QUADRIVE  
DRC 18/4, PDC 18/4 ..... 207, 216, 236  
Quick-action clamp ..... 370

- R**
- Radius profile sanding pad
    - LS 130..... 99
  - RAP 150.....86, 124-125
  - RAP 80.....85, 124-125
  - Rapid charger MXC.....215
  - RAS 115.....73, 100
  - RAS 180.....74, 100
  - Rebate depth stop.....196
  - Rebate profile sanding pad
    - SSH-STF-LS130-90 GR
      - LS 130..... 99
  - Rebating cutter.....172
  - Rebating head.....366
  - Recessed grip/Hand rail cutter.....173
  - Refurbishment, Drywalling and Renovation
    - Accessories and Consumables.....324-331
    - Overview Products and Applications.....314-316
  - RENOFIX
    - RG 130.....319, 328
    - RG 150.....318, 327
    - RG 80.....317, 326
  - Renovating.....312-331
  - Renovation miller
    - RENOFIX RG 150.....318, 327
    - RENOFIX RG 80.....317, 326
  - Repair compound
    - SSP.....47
  - Replacement roller
    - TP 220.....331
  - Reversible blade.....366
  - Reversible blade rebating cutter.....159, 167
  - Reversible cutter blade.....343, 344
  - RG 130.....319, 328
  - RG 150.....318, 327
  - RG 80.....317, 326
  - RO 125.....59, 93, 124
  - RO 150.....60, 94, 124
  - RO 90 DX.....58, 92, 124
  - Rod
    - OF 2200.....158
  - Roller stand
    - RB.....34, 35, 366
  - Roman ogee cutter.....176
  - Rotary polisher
    - POLLUX 180.....87, 124-125
    - RAP 80.....85, 124-125
    - SHINEX RAP 150.....86, 124-125
  - Rotary sanders
    - RAS 115.....73, 100
    - RAS 180.....74, 100
  - ROTEX
    - RO 125.....59, 93, 124
    - RO 150.....60, 94, 124
    - RO 90 DX.....58, 92, 124
  - Roundover cutter.....168
  - Roundover/Chamfer cutter.....169
  - Router
    - OF 1010.....138, 156, 159, 163
    - OF 1400.....139, 157, 159
    - OF 2200.....140, 158, 159
  - Router carriage
    - MFS 400, MFS 700.....159
  - Router table.....162
    - MFK 700.....162
  - Routing aid
    - OF 900, OF 1000, OF 1010, OF 1400,  
OF 2000, OF 2200.....157, 158, 161
  - Routing template
    - MFS.....144, 159
    - OF 1010, OF 1400, OF 2200.....159
  - RS 100.....66, 97
  - RS 200.....67, 97
  - RS 300.....68, 97
  - RTS 400.....69, 98
  - Rubber battery pack frame
    - BPC 15, BPC 18.....214, 215, 216, 217
  - Rubin 2.....108-112, 114, 116-117, 119-122
  - Rustic planer heads.....197
  - Rustilon brushes
    - BMS 180.....106
  - RUSTOFIX
    - BMS 180.....89, 106

**S**

    - Safety filter bag.....293
    - Sanding base
      - BS 75, BS 105.....101
    - Sanding block HSK.....106, 260
    - Sanding cloth STF.....133
    - Sanding frame
      - BS 75, BS 105.....101
    - Sanding pad StickFix ST-STF, SSH-STF
      - LRS 93, LRS 400, RS 300, RS 3.....104
      - RO 90 DX.....92
      - RS 100, R 200, RS 300, RS 1, RS 2, RS 3,  
LRS 93.....97
      - RTS 400, RS 400, DS 400, DX 93,  
RO 90 DX.....98
    - Sanding pad ST-STF
      - ETS 125.....95, 125
      - ETS 150, LEX 150, WTS 150/7.....96
      - LEX 3 77, LEX 3 125, LEX 3 150,  
LEX 2 185.....102
      - LHS 225.....330
      - RAS 115, RAS 180.....100
    - Sanding pad system.....65
    - Saphir.....108, 111, 113, 115-117, 122
    - Saw blade holder
      - SGA.....34, 366
    - Saw blades
      - for circular saws.....38-41
      - for jigsaws.....42-45
      - Overview.....36, 37
    - Sawing and Oscillating Accessories.....28-47
    - Sawing and Oscillating Overview
      - Products and Applications.....8-11, 26
    - Scraper.....260
    - Scraper SSH
      - LS 130.....99
    - Scratch protector.....260
    - Script cutter.....174
    - Sealant.....126
    - Sealing slide
      - CT AC, CT 36 AC PLANEX.....296
    - Self-adhesive sanding disc.....127
    - SELCLEAN filter bag.....279, 292
    - Semi-stationary sawing.....29
    - Service unit
      - TC 2000, TC 3000.....373
    - Sheepskin.....124, 128-132
    - Shelf
      - WCR 1000, UCR 1000.....372
    - Side stop
      - MFK 700.....162
      - OF 1400.....157
      - OF 2200.....158
      - OF 900, OF 1000, OF 1010, KF.....156
    - Slat sanding pad
      - LS 130.....99
      - RTS 400, DTS 400, DX 93.....98
    - Slideway lining
      - FS/2.....370
    - Sliding compound mitre saw
      - KAPEX KS 120.....21, 32
      - KAPEX KS 88.....20, 32
    - Sliding table
      - CS 70 ST.....35, 366
      - ST.....34
    - Slot joint template.....160
    - Socket
      - EAA.....369
    - SORTAINER.....375
    - Spare felt
      - KA 65.....260
      - PS 420.....30
    - Special blade
      - SSB 32.....47
    - Special nozzles/brushes.....289-290
    - Special saw blade.....40, 44
    - Special wood saw blade.....38
    - Specialised cutters for mineral
      - materials.....184-187
    - Spiral blade
      - EHL 65, HL 850.....191, 196
    - Spiral groove cutter.....161
    - Splinterguard
      - CS 50 SP/10.....34
      - CS 70 SP/10.....35
      - FS-SP.....370
      - SP-PS/PSB 300/20.....30
      - SP-PS/PSB 300/5.....30
      - SP-TS 55 R/5.....31
      - SP-TS 55/5.....31
    - Spot sander.....127
    - Spray sealant.....126, 128
    - SR compressed air accessories.....297
    - SR disposal bag.....295
    - SR filter.....294
    - SR filter bags.....294
    - SR filters and filter bags for discontinued
      - models.....295
    - SSU 200.....335
    - Standard saw blade.....42
    - Stationary unit SE
      - EHL 65, HL 850.....196
    - Stepped cutters.....168
    - Stirrer rods.....308-310
    - Stirrers
      - MX 1000, MX 1000/2, MX 1200.....303
      - MX 1200/2, MX 1600/2.....304
      - MX 1600/2 DUO.....305
    - Stirring Accessories and
      - Consumables.....304-311
    - Stirring Overview Products and
      - Applications.....300-301
    - Stop tab
      - KA-AR.....32, 34, 35
      - OF 900, OF 1000, OF 1010, OF 1400.....161
      - WA-AR.....34, 35, 366
    - Suction hose.....285
    - Support
      - AF.....34, 366
      - AFB.....158
    - Surface Finishing Accessories.....90-133
    - Surface Finishing Overview Products
      - and Applications.....50-57

**SURFIX**  
 OS ..... 88, 133  
 Switch cover  
 SAB ..... 35  
 Sword saw  
 IS 330 ..... 336, 342  
 UNIVERS SSU 200 ..... 335, 342  
 SYM 70 ..... 22, 33  
 SYMMETRIC SYM 70 ..... 22, 33  
 SYS roller ..... 363, 376  
 SYS tool box ..... 362, 375  
 SYS-Cart ..... 363  
 SYS-Dock ..... 76  
 SYSLITE KAL ..... 361  
 SYS-Port ..... 363  
 SYS-StorageBox ..... 375  
 SYSTAINER ..... 362  
 SYS-STF-D77/D90/93V ..... 92, 98, 103  
 Systainer pull-out ..... 376  
 SYSTAINER T-LOC ..... 362, 374  
 for Festool machines ..... 377  
 SYS-MFT ..... 379  
 SYS-STF ..... 93-100, 103, 104, 330  
 with inlay for hand tools ..... 379  
 with inserts for abrasives ..... 376  
 with lid compartment DF ..... 375  
 with universal insert ..... 378  
 without inserts ..... 362, 374  
 Systainer-Port ..... 376

**T**  
 T 15+3 ..... 124, 205, 214  
 T 18+3 ..... 205, 214, 234  
 Table preparation  
 VB ..... 34  
 Table top insert  
 TE-SYM 70 ..... 33  
 TC 3000/2 ..... 360, 373  
 TCL 3 ..... 30, 31  
 Template set VS 600 ..... 160  
 TF 1400 ..... 143  
 TF 2200 ..... 143  
 Titan 2 ..... 108-109, 113, 115-116, 118, 124  
 Tongue and groove cutters ..... 174  
 Tool chuck  
 CENTROTEC ..... 214-216  
 Tool head  
 RG 150 ..... 327  
 RG 80 ..... 326  
 Tool holder  
 CT 36 PLANEX ..... 296, 330  
 TC 2000, TC 3000, TC 3000/2 ..... 373  
 Tool hook  
 WCR 1000, UCR 1000 ..... 372  
 Toolcenter  
 TC 3000/2 ..... 360, 373  
 Tooling times ..... 23  
 TP 220 ..... 323, 331  
 TPE-RS 100 ..... 322, 331  
 Trammel unit  
 OF 900, OF 1000, OF 1010, KF ..... 156  
 Transport rollers  
 CS 70 TR ..... 35  
 Triangular sander  
 DELTEX DX 93 ..... 71  
 Trim stop  
 DF 500, DF 700 ..... 247, 249

Trimming attachment  
 CS 70 KA ..... 34, 35  
 KA-KS-L ..... 32  
 KA-KS-R ..... 32  
 KA-UG-L ..... 32  
 KA-UG-R ..... 32  
 Trimming machine KP 65/2 ..... 255  
 Trimming saw  
 KAPEX KS 120 ..... 21  
 KAPEX KS 88 ..... 20  
 PRECISIO CS 50 ..... 24, 34  
 PRECISIO CS 70 ..... 25, 35  
 TRION PS 300 ..... 12  
 TRION PSB 300 ..... 12  
 TS 55 R ..... 16, 31  
 TS 75 ..... 18, 31  
 TSC 55 ..... 17, 31, 233  
 Tubes ..... 288  
 Turbfilter TF  
 RS 300, R 3, RS 200, R2, ETS 150,  
 ES 150, ET 2 ..... 96, 97  
 RS 400, RTS 400, DS 400, DTS 400,  
 ES 125, ETS 125 ..... 95, 98  
 Turning plate chamfer/edge trimming  
 cutter ..... 169  
 Turning plate edge trimming cutter ..... 171  
 Twin-column guide ..... 23  
 Twist drill bit ..... 220

**U**  
 UCR 1000 ..... 359, 372  
 Underframe  
 UG-KAPEX ..... 32  
 UG-KA-Set ..... 32  
 UNIVERS  
 SSU 200 ..... 335  
 Universal hook  
 WCR 1000, UCR 1000 ..... 372  
 Universal saw blade ..... 38, 42  
 Universalcenter  
 UCR 1000 ..... 359, 372

**V**  
 VAC SYS ..... 351, 368  
 Vacuum clamping nozzle  
 CT WINGS ..... 296, 355  
 Vacuum clamping system  
 VAC SYS ..... 351, 368  
 Vacuum hose ..... 368  
 Vacuum pad VAC SYS ..... 368  
 Vacuum pump VAC SYS ..... 368  
 VECTURO  
 OS 400 ..... 27, 46  
 V-groove cutters ..... 163, 174  
 V-groove profile sanding pad  
 LS 130 ..... 99  
 Vlies ..... 108, 113, 115, 118

**W**  
 Wallpaper perforator  
 TP 220 ..... 323, 331  
 Water gutter cutter ..... 170  
 WCR 1000 ..... 358, 372  
 Wet filter ..... 291  
 Wood saw blade  
 HSB ..... 47

Wooden Structures Accessories  
 and Consumables ..... 340-345  
 Wooden Structures Overview Products  
 and Applications ..... 334  
 Work light ..... 361  
 Workcenter  
 WCR 1000 ..... 358, 372  
 Worktop template  
 APS ..... 145, 159  
 WTS 150 ..... 64, 96

**Z**  
 ZOBO  
 Centering tip ..... 224  
 Depth gauge ..... 224  
 Drill bit ..... 223  
 Extension ..... 224  
 Forstner drill bit ..... 223

## General notes on the catalogue:

1. Please remember to fit appropriate protective devices or wear personal protective equipment when using Festool products such as compressed air and electric power tools with accessories and consumable materials or when machining hazardous materials. For further information, please refer to the relevant safety documentation or consult the relevant regulating authority if you have questions.
2. Machine specifications included in the catalogue, such as quantity specifications, time savings, coverage capacities, etc., are average values and may deviate significantly, depending on the material being processed. The manufacturer does not guarantee that the values will be achieved in each individual case. Your Festool specialist dealer will be glad to answer any queries you may have concerning this matter.
3. All trade mark rights, patent rights and other commercial rights mentioned in this catalogue remain the property of the relevant beneficiary, even in cases where this is not explicitly stated. The use of brand names, trade names, trade marks, etc. in this catalogue (even if not identified as such) does not render these names exempt from trade mark protection and does not therefore authorise anyone to use them.
4. We reserve the right to make modifications, especially to technical data or specifications, without prior notification. Individual features may vary in accordance with country-specific conditions.
5. Products may differ from those pictured and the images may at times present components or parts that are not included with the products. If you have any questions, please contact your Festool dealer.
6. Safety: All electric and compressed air tools listed in this catalogue conform to all valid and applicable IEC or EN safety standards, depending upon the type of tool (IEC/EN 61 029, IEC/EN 60 745, IEC/EN 60 335, EN ISO 11 148, IEC/CISPR/EN 55 014, IEC/EN 61 000).
7. CE conformity: All electric power tools and compressed air tools listed in this catalogue comply with the conditions specified in applicable EU directives (Machine Directive 2006/42/EC, Low Voltage Directive 2006/95/EC, EMC Directive 2004/108/EC, RoHS guideline 2011/65/EU).
8. ISO certification: all the electric power tools and compressed air tools listed in this catalogue are manufactured in production plants that are ISO 9001 certified.
9. Insulation: The electric power tools listed in this catalogue are fully insulated in accordance with regulations.
10. The machine weights specified in the catalogue usually refer to the weight of a machine ready for use and with a standard tool attached, but without a cable, accessories or consumable materials. Please remember that specified weights may deviate from the specifications detailed in the catalogue, depending on the tool, battery pack, accessories or other additional parts.





## Egypt

Equipment plus sarl  
Mkales street 41  
Beirut  
Tel. 00961 16 92 136  
Fax 00961 99 25 993  
info@equipment-plus.com  
[www.equipment-plus.com](http://www.equipment-plus.com)



## Algeria

PRO DISTRIBUTEUR sarl  
NIF 099909080287849  
BP 61F LOT AIDJAT NORD  
09400 W. Blida Algerie  
Tel. 00213 25 47 12 94  
Fax 00213 25 47 35 85  
info@pro-dist.com  
[www.pro-dist.com](http://www.pro-dist.com)



## Armenia

Niko International LLC  
16 Tigranyan Str.  
0014 Yerevan  
Tel. 0037 41 028 54 14  
Fax 0037 41 028 74 47  
importexport@niko.am  
[www.kapeuro.am](http://www.kapeuro.am)



## Azerbaijan

Alman Texnikalari Evi MMC  
Darnagol, Z. Bunyadov str. 1  
1069 Baku  
Tel. 0099 41 25 61 87 03  
Fax 0099 41 25 61 87 03  
ate\_mmc@yahoo.com



## Australia

Festool Australia  
63-65 Quantum Close  
South Dandenong VIC 3175  
Postal address: PO Box 4401  
Dandenong South VIC 3164  
Tel. 1300 063 900  
Fax 0061 3 9799 9766  
customer@tooltechnic.com.au  
[www.festool.com.au](http://www.festool.com.au)



## Belgium

Tooltechnic Systems (Belgium) N.V./S.A.  
Agent Festool  
Rue Colonel Bourgstraat 101  
1030 Brussel  
Tel. 0032 2 702 32 38  
Fax 0032 2 726 98 81  
info-be@tts-festool.com  
[www.festool.be](http://www.festool.be)



## Bosnia-Herzegovina

MAJO D.O.O.  
Goričica pri Ihanu 2  
1230 Domžale (Slovenija)  
Tel. 00386 17 24 82 16  
Fax 00386 17 24 11 07  
majo.doc@siol.net  
[www.majo.si](http://www.majo.si)



## Brazil

LINK Comercial Importadora e Exportador Ltda  
Rua Arnaldo Hass, 100  
BLUMENAU, SC. Brazil  
89107-000 Pomerode-SC  
Tel. +55 47 32859697  
Fax +55 47 88369697  
hermes@mafetec.com.br  
[www.mafetec.com.br](http://www.mafetec.com.br)



## Brazil

W&S Saura Ltda.  
Av. José Fortunato Santon 580  
Distrito Industrial Abdo Najjar  
13474-750 Americana/ São Paulo  
Tel. 0055 19 3469-9889  
Fax 0055 19 3469-9888  
ws@wsequipamentos.com.br  
[www.wsequipamentos.com.br](http://www.wsequipamentos.com.br)



## Bulgaria

Tooltechnic Systems E00D  
9, Christopher Columbus Blvd.  
1592 Sofia  
Bulgaria  
Tel. 00359 888574208, 00359 888989911  
office@festool.bg  
[www.festool.bg](http://www.festool.bg)



## Chile

Barends y Perez Limitada  
San Martin 225  
4780000 Temuco  
Tel. 0056 9 98810207  
fperez@bypools.cl



## China

Festool China  
1159 Kangqiao East Rd, No.91-Buildg 1  
Kangqiao Industrial Zone  
201315 Shanghai (Pudong)  
Tel. 0086 21 68 18 28 00  
Fax 0086 21 68 18 26 90  
info@festool.com.cn  
[www.festool.cn](http://www.festool.cn)



## Denmark

Tooltechnic Systems ApS  
Postboks 1242  
2300 København S  
Tel. 0045 44 84 20 24  
Fax 0045 44 84 20 44  
info-dk@festool.com  
[www.festool.dk](http://www.festool.dk)



## Germany

TTS Tooltechnic Systems Deutschland GmbH  
Markenvertrieb Festool  
Wertstrasse 20  
73240 Wendlingen a.N.  
Tel. 0049 (0)7024/ 804-24010  
Fax 0049 (0)7024/ 804-29699  
vertrieb@tooltechnicsystems.com  
[www.festool.de](http://www.festool.de)



## Estonia

UAB „TTS Tooltechnic Systems“  
Ašigalio g. 6  
LT-49142, Kaunas, Lietuva  
Tel. 00370 37 308 414  
Fax 00370 37 323 848  
info@tts-company.lt  
[www.festool.ee](http://www.festool.ee)



## Finland

Tooltechnic OY  
Mäkituvantie 7  
01510 Vantaa  
Tel. 00358 10 22 95 110  
Fax 00358 98 25 47 132  
tooltechnic@tooltechnic.fi  
[www.festool.fi](http://www.festool.fi)



## France

Festool France  
47 Grande Allée du 12 Février 1934, Noisiel  
77448 Marne la Vallée Cedex 2  
Tel. 00 33 (1) 60 06 44 30  
Fax 00 33 (1) 60 06 62 26  
info-fr@tts-festool.com  
[www.festool.fr](http://www.festool.fr)



## Georgia

LTD Electron  
Gardabani highway No. 48  
0160 Tbilisi  
Tel. 00995 322 38 23 02  
Fax 00995 322 38 23 01  
contact@rcheuli.com



## Greece

Hellenic Tool Center  
Driadon 4  
141 22 Neo Heraklio (Attica)  
Tel. 0030 21 02 81 10 72  
Fax 0030 21 02 81 17 64  
festool@otenet.gr  
[www.festool.gr](http://www.festool.gr)



## Great Britain

TTS Tooltechnic Systems GB Ltd.  
Saxham Business Park, Saxham  
Bury St. Edmunds, Suffolk  
IP28 6RX  
Tel. 0044 1284 760 791  
Fax 0044 1284 702 156  
info@festool.co.uk  
[www.festool.co.uk](http://www.festool.co.uk)



## India

Cable Traders  
Gr Floor, Navdurga Shah Arcade Bldg No 8  
Near Rani Sati (Pathanwadi)  
Flyover & Sai Baba Mandir  
WE Highway, Malad E, Mumbai 400097  
Tel. 00919930069901  
info@cable.in



## Ireland

TTS Tooltechnic Systems Ireland Ltd  
C/O McCann Duffy Cleary, E12 Calmount Park  
Ballymount  
Dublin 12  
Tel. 00353 18 64 22 40  
Fax 00353 18 64 22 47  
sales@festool.ie  
[www.festool.ie](http://www.festool.ie)



## Iceland

ISOL Ltd.  
P.O. Box 8436  
128 Armúli 17 Reykjavik  
Tel. 00354 53 31 234  
Fax 00354 56 80 499  
isol@isol.is  
[www.isol.is](http://www.isol.is)



## Israel

A. Sherizly & Son Ltd.  
Shderot Hamiksoot, 15  
Einav Center  
Modiin - 7177849  
Tel. 00972 89 23 37 77  
Fax 00972 89 23 44 77  
sherizly@sherizly.com  
[www.festool.com](http://www.festool.com)



## Italy

Festool Italia S.r.l.  
Distributore del marchio Festool  
Via Enrico Fermi 36-38  
20090 Assago MI  
Tel. 0039 02 457851  
Fax 0039 02 45785320  
marketingit@festool.com  
[www.festool.it](http://www.festool.it)



## Japan

Háfele Japan K.K.  
14-17, Kami-Shinano, Totsuka-ku  
244-0806 Yokohama  
Tel. 0081 45 82 83 111  
Fax 0081 45 82 83 110  
festool@hafele.co.jp  
[www.festool.jp](http://www.festool.jp)



## Jordan

Equipment plus sarl  
Mkales street 41  
Beirut  
Tel. 00961 16 92 136  
Fax 00961 99 25 993  
info@equipment-plus.com  
[www.equipment-plus.com](http://www.equipment-plus.com)



## Canada

Tooltechnic Systems, LLC  
400 N. Enterprise Blvd  
Lebanon, IN 46052  
Tel. 001 88 83 37 86 00  
Fax 001 76 54 83 09 03  
sales@festoolcanada.com  
[www.festoolcanada.com](http://www.festoolcanada.com)



## Kazakhstan

Voronin I.V.  
Mikrorayon Aksay 3 a, dom 80  
050031 Almaty  
Tel. 007 727 2757007  
ritm@escort.kz  
[www.ritm.ltd.kz](http://www.ritm.ltd.kz)



## Qatar

Equipment plus sarl  
Mkales street 41  
Beirut  
Tel. 00961 16 92 136  
Fax 00961 99 25 993  
info@equipment-plus.com  
[www.equipment-plus.com](http://www.equipment-plus.com)



## Columbia

Pinturas Solvana Ltda.  
Cr 59C 131-56  
Bogotá, D.C.  
Tel. 0057 613 4023  
Fax 0057 226 1609  
info@pinturassolvana.com  
[www.pinturassolvana.com](http://www.pinturassolvana.com)



## Croatia

ALAGO d.o.o.  
Horvati 112  
10436 Rakov Potok  
Tel. 00385 1 653 93 92  
Fax 00385 1 653 93 93  
info@alago.hr  
[www.alago.hr](http://www.alago.hr)



## Latvia

UAB „TTS Tooltechnic Systems“  
Ašigalio g. 6  
LT-49142, Kaunas, Lietuva  
Tel. 00370 37 308 414  
Fax 00370 37 323 848  
info@tts-company.lt  
[www.festool.lv](http://www.festool.lv)



## Lebanon

Equipment plus sarl  
Mkales Street 41  
Beirut, Lebanon  
Tel. 00961 1 692136  
Mobile 00961 71 861234  
info@equipment-plus.com  
[www.equipment-plus.com](http://www.equipment-plus.com)



## Lithuania

UAB „TTS Tooltechnic Systems“  
Ašigalio g. 6  
LT-49142, Kaunas, Lietuva  
Tel. 00370 37 308 414  
Fax 00370 37 323 848  
info@tts-company.lt  
[www.festool.lt](http://www.festool.lt)



## Luxembourg

Tooltechnic Systems (Belgium) N.V./S.A.  
Agent Festool  
Rue Colonel Bourgstraat 101  
1030 Brussel  
Tel. 0032 2 702 32 38  
Fax 0032 2 726 98 81  
info-be@tts-festool.com  
[www.festool.be](http://www.festool.be)



## Malta

PIOVE HOLDINGS Ltd.  
Triq id-Dielja 43  
5200 Qormi QRM 04  
Tel. 00356 21 44 67 98  
Fax 00356 21 44 44 76  
piove@usa.net  
[www.festool.net](http://www.festool.net)



## Macedonia

Rosa Doel  
str. Jadranska magistrala 90  
1000 Skopje  
Tel. 00389 022 602 092  
Fax 00389 022 602 093  
info@rosa.com.mk  
[www.rosa.com.mk](http://www.rosa.com.mk)



## Moldova

UAB „TTS Tooltechnic Systems“  
Ašigalio g. 6  
LT-49142, Kaunas, Lietuva  
Tel. 00370 37 308 414  
Fax 00370 37 323 848  
info@tts-company.lt  
[www.tts-company.lt](http://www.tts-company.lt)



## Mexico

Etapel, S.A. de C.V.  
California No. 167  
Col. Parque San Andrés  
D.F. 04040 Mexico  
Tel. 0052 55 56 89 50 55  
Fax 0052 55 56 89 99 11  
mfrandes@etapel.com.mx  
[www.etapel.com](http://www.etapel.com)



## New Zealand

Hindin Marquip Ltd.  
1012 Great South Road  
1061 Penrose - Auckland  
Tel. 0064 9 9131661  
hamish@hml.co.nz



## The Netherlands

Tooltechnic Systems BV  
Coenecoop 2 G  
2741 PG Waddinxveen  
Tel. 0031 18 26 21 940  
Fax 0031 18 26 21 949  
info-nl@festool.com  
[www.festool.nl](http://www.festool.nl)



## Norway

MOTEK AS  
Alf Bjerkesvei 22 B  
BOX 81 Oekern  
0508 Oslo  
Tel. 0047 23 05 25 00  
Fax 0047 22 64 00 63  
odd-arve.rygh@motek.no  
[www.motek.no](http://www.motek.no)



## Austria

Tooltechnic Systems GmbH  
Markenvertrieb Festool  
Schloss Glanegg 2  
5082 Grödig  
Tel. 0043 62 46 74 103  
Fax 0043 62 46 74 279  
vertrieb\_at@tts-company.com  
[www.festool.at](http://www.festool.at)



## Panama

Formica Distribution Center, S.A.  
City of Panama, Panama, street  
85, Urb. Ind. Los Angeles  
0832-2532 WTC PANAMA  
Tel. 00507 260 5503  
Fax 00507 260 1440  
grettel.amores@bacosa.com



## Paraguay

Renpar S.A.  
Juan Leopardi N° 1879 c/ Pedro Peña  
2160 San Lorenzo  
Tel. 00595 21 51 13 29  
Fax 00595 21 51 13 29  
nlopes@renpar.com.py  
[www.festool.com](http://www.festool.com)



## Peru

EURO IMPORT TOOLS SRL.  
Costa Rica N° 513  
J. Hunter, Arequipa  
Tel. 0054 959 26 03 46  
Fax. 0054 61 99 67  
euroimportacion@hotmail.com  
[www.euro-importacion.com](http://www.euro-importacion.com)



## Philippines

HAFELE PHILIPPINES INCORPORATED  
Levi Mariano Avenue  
Barangay Ususan, Taguig City  
1638 Metro Manila  
Tel. 0063 [2] 571 3678  
Fax 0063 [2] 571 3693  
stefan.wolf@hafele.com.ph



## Poland

Festool Polska Sp. z o.o.  
Sokotów, ul. Sokotowska 47a  
05-806 Komorów  
Tel. 0048 22 122 74 00  
Fax 0048 22 122 74 01  
info-pl@festool.com  
[www.festool.pl](http://www.festool.pl)



## Portugal

Tooltechnic Systems Unipessoal, Lda  
Zona Industrial Pau Queimado  
E.N. 5, Armazém 25  
2870-500 Montijo  
Tel. 0034 932 643 030  
Fax 0034 932 643 031  
info-pt@tts-company.com  
[www.festool.pt](http://www.festool.pt)



## Romania

Tooltechnic System Kft.  
Gyömrői út 150. V-3 épület  
1103 Budapest  
Tel. 0036 12 97 13 50  
Fax 0036 12 97 13 59  
info@festool.hu  
[www.festool.hu](http://www.festool.hu)



## Russia

TTS Tooltechnic Systems 000  
Russia, Moscow region  
Noginsk district, 142400 Noginsk,  
„Noginsk-Technopark“ area, 13  
Tel. 007 49 57 75 83 54  
Fax 007 49 56 41 23 72  
festool@tooltechnic.ru  
[www.festool.ru](http://www.festool.ru)



## Sweden

Tooltechnic Systems Sverige AB  
Stenåldersgatan 3  
213 76 Malmö  
Tel. 0046 40 670 10 00  
Fax 0046 40 670 10 39  
info-se@festool.com  
[www.festool.se](http://www.festool.se)



## Switzerland

Festool Schweiz AG  
Moosmattstr. 24  
8953 Dietikon  
Tel. 0041 44 744 27 27  
Fax 0041 44 744 27 28  
info-ch@festool.com  
[www.festool.ch](http://www.festool.ch)



## Serbia

MAKSAL LINE D.O.O.  
Pavla Pavlovića 11  
11000 BEOGRAD  
Tel. 00381 64 127 7581  
maksal.bg@gmail.com  
[www.maksal-line.rs](http://www.maksal-line.rs)



## Slovakia

Festool SK s.r.o.  
Kamenná 91  
SK - 010 01 Žilina  
Tel. 00420 48 16 45 16 2  
Fax 00420 48 16 45 16 3  
festool.info@festool.com  
[www.festool.sk](http://www.festool.sk)



## Slovenia

MAJO D.O.O.  
Goričica pri Ihanu 2  
1230 Domžale  
Tel. 00386-17 248 216  
Fax 00386-17 241 107  
majo.doo@siol.net  
[www.majo.si](http://www.majo.si)



## Spain

TTS Tooltechnic Systems, S.L.U.  
Paseo de la Zona Franca 69-73  
08038 Barcelona  
Tel. 0034 93 26 43 030  
Fax 0034 93 26 43 031  
info-es@tts-company.com  
[www.festool.es](http://www.festool.es)



## South Korea

URO Corporation  
52-20 Ogum-dong, Songpa-Gu  
138-857 Seoul  
Tel. 0082 24 03 80 11  
Fax 0082 24 48 95 11  
shin@uro.kr  
[www.uro.kr](http://www.uro.kr)



## Sri Lanka

Hafele India Pvt. Ltd.  
Sri Lanka Branch  
885 ETHUL KOTTE ROAD  
ETHUL KOTTE  
Sri JAYAWARDENAPURA  
Tel. 0094 112 889 882  
Fax 0094 11 7537 701  
srilanka@hafeleindia.com



## Taiwan

Bestor Trading Corp.  
No.12, Chung-Yang Lane  
Kuang-Fu Village Shetou  
Hsiang Chang-Hua Hsien  
Tel. 00886 48 72 66 97  
Fax 00886 48 72 52 09  
bestor.steven@msa.hinet.net  
[www.bestor.com.tw](http://www.bestor.com.tw)



## Thailand

Häfele (Thailand) Ltd.  
57 Soi Sukhumvit 64  
Bangjak Prakhonong  
10260 Bangkok  
Tel. 0066 27 41 71 71  
Fax 0066 27 41 72 72  
festool@hafele.co.th  
[www.hafele.com/th/en](http://www.hafele.com/th/en)



## Czech Republic

Festool CZ s.r.o.  
Chelčického 1932  
CZ - 470 37 Česká Lípa  
Tel. 00420 48 16 45 162  
Fax 00420 48 16 45 163  
festool.info@festool.com  
[www.festool.cz](http://www.festool.cz)



## Turkey

GEDORE EL ALETLERI SAN. ve TİC. LTD. ŞTİ.  
Birlik Org. San. Bölgesi Tem Yan Yolu  
1. Cad. 4. Sok. No:1  
34953 Aydınlı-Tuzla / İstanbul  
Tel. 0216 395 32 00  
Fax 0216 395 32 03  
info@gedore.com.tr  
[www.festool.com.tr](http://www.festool.com.tr)



## Ukraine

UAB „TTS Tooltechnic Systems“  
Ašigalio g. 6  
LT-49142, Kaunas, Lietuva  
Tel. 00370 37 308 414  
Fax 00370 37 323 848  
info@tts-company.lt  
[www.festool.ua](http://www.festool.ua)



## Hungary

Tooltechnic System Kft.  
Gyömrői út 150. V-3 épület  
1103 Budapest  
Tel. 0036 12 97 13 50  
Fax 0036 12 97 13 59  
info@festool.hu  
[www.festool.hu](http://www.festool.hu)



## Uruguay

Luganer S.A.  
Democracia 2090  
Montevideo 11800  
Tel. 00598 24 01 76 08  
Fax 00598 24 01 76 08  
centrodeventas@luganer.com.uy  
[www.luganer.com.uy](http://www.luganer.com.uy)



## USA

Tooltechnic Systems, LLC  
400 N. Enterprise Blvd  
Lebanon, IN 46052  
Tel. 001 88 83 37 86 00  
Fax 001 76 54 83 09 03  
sales@festoolusa.com  
[www.festoolusa.com](http://www.festoolusa.com)



## United Arab Emirates

POLIMAR  
Unit D-8 Sharjah Furniture Complex  
Al Wahda Street  
P.O. Box 433 Sharjah  
Tel. 00971 65 33 41 47  
Fax 00971 65 33 00 09  
polimar@emirates.net.ae  
[www.polimar.com](http://www.polimar.com)



## Belarus

UAB „TTS Tooltechnic Systems“  
Ašigalio g. 6  
LT-49142, Kaunas, Lietuva  
Tel. 00370 37 308 414  
Fax 00370 37 323 848  
info@tts-company.lt  
[www.festool.by](http://www.festool.by)



## Cyprus

K and S Industrial Supplies Ltd.  
31 Vasilissis Freiderikis Road  
P.O. Box 27147  
1642 - Nicosia  
Tel. 00357 22 67 46 64  
Fax 00357 22 67 22 40  
seraphim@cytanet.com.cy  
[www.festool.com](http://www.festool.com)

# FESTOOL

Tools for the toughest demands

## **Festool GmbH**

Wertstrasse 20  
D-73240 Wendlingen

## **TTS Tooltechnic Systems GB Ltd**

Saxham Business Park  
Saxham  
Bury St Edmunds  
Suffolk  
IP28 6RZ  
Great Britain  
Phone : +44 (0) 1284 760 791  
Fax: +44 (0) 1284 702 156  
E-mail [info@festool.co.uk](mailto:info@festool.co.uk)

[www.festool.co.uk](http://www.festool.co.uk)

**Product No. 064 316 GB/en**



4 0 1 4 5 4 9 1 2 3 9 4 4 5

## **Festool catalogue 2015**

Date: 01/2015, replaces all previous catalogues.

Subject to alterations and errors. Products may differ from those pictured.

Recommended retail price of manufacturer. Prices valid from 01.01.2015.

Dealer prices may vary.

## Product identification key

Product type	Performance class	Equipment variants	Packed in a SYSTAINER	Also included in delivery
<b>RO</b>	<b>150</b>	<b>FEQ</b>	<b>Plus</b>	<b>Set</b>
	Pad Ø, container volume, etc.	<b>F</b> Tool change system <b>E</b> Electronic <b>CE</b> CENTROTEC <b>Q</b> Plug it <b>SG</b> Hose garage <b>EW</b> Electric tool <b>DW</b> Compressed air tool <b>LE</b> Compressed air variant	with a SYSTAINER	Extensive range of accessories included with the product

**In self-service display pack** Accessory is positioned in the retailer for self-operation

## Product performance features



### Antistatic function

Mobile dust extractors and tools with the antistatic function to prevent static charge from accumulating when working.



### Dual-line laser

Two laser lines for simple, precision positioning along the scribe mark from the left or right.



### Torque shut-off

Intelligent technology ensures the optimum screwdriving force for every material.



### Electronic

Speed control for adjusting to all types of materials.



### AUTOCLEAN

AUTOCLEAN automatic main filter cleaning system with infinitely adjustable cleaning intervals.



### FlowDetect

Flow sensor checks for a minimum air speed of 20 m/sec and issues a warning if the air speed falls below this value. For better health protection.



### Jigsaw with precision guidance

Long-wearing carbide jaws guide the saw blade directly over the cutting location. For precise work results.



### MMC electronics

Modern "Multi Material Control" power electronics with constant adjustable speed and temperature monitor for work on all types of material.



### Standard connection

Built-in connector for dust extraction



### PoliStick

Fast fixing concept for attaching polishing felt, polishing sponges or sheepskins - for greater efficiency.



### MMC digital electronics

Processor controlled "Multi Material Control" power electronics provide adjustable and constant speeds as well as temperature monitoring for work on all types of material.



### IAS 3 system

Hose system incorporates compressed air, dust extraction and exhaust air.



### MPE sanding pad

Sanding pads and sanding discs made from extremely durable materials for long service life.



### Spir-O-Cut

The single-edged planer head offers decisive advantages - no need to adjust the cutting circle diameter after blade replacement as well as a drawing cut for high surface quality.



### IAS 3-SD

For connecting a Festool compressed air sander directly to a compressed air line (without dust extraction).



### EC-TEC

The EC-TEC drive concept generates an extraordinary amount of power while consuming extremely low amounts of energy.



### StickFix

Quick, economical fastening system for abrasives - no adhesives, no clamping.



### IAS 3 light

Dust extraction, compressed air with external exhaust air dissipation, ideal for machines with oil-free motor.



### Lithium ion

Fitted with high-performance lithium ion battery pack.



### Jetstream principle.

The 9-hole principle for reduced dust accumulation, less heat and less clogging. Up to a 30 % longer service life.



### Forward/Reverse rotation

For screwing and unscrewing screws.



### SDS-plus

Tool holder for quick tool changes.



### MULTI-JETSTREAM principle

Sanding system with integral dust conveying concept. With the patented MULTI-JETSTREAM principle.



### High torque

Tool with high torque.



### Protector

Protects the sanding pad and material when working close to edges.



### Impact stop

Allows manual deactivation of the impact function when drilling into wood or brittle materials.



### Electronic monitoring

Electronic monitoring of the coil temperature protects against damage to the motor.



### Splinter guard

Patented splinterguard for splinter-free cuts on both sides when sawing.



### Safety sliding clutch

Mechanical sliding clutch provides protection if the tool suddenly seizes or tilts.



### Start/stop function

AUTO mode, also without having to press the main switch.



### Guide system

Patented guide system for safe guidance of saws and router bits.



### Quick-acting brake

For safe work when planing, sawing and routing.



### ErgoFix adapter

For holding a M14 stirring rod.



### plug it

Removable, replaceable mains cable with safety lock for quick conversion.



### FastFix

Makes changing routing, sawing, planing, sanding, drilling and screwdriving tools easier.



### Starting current limiter

Simple start for household fuses.



### Vibration stop.

Patented VS balancing so that tools run smoothly during sanding, which makes working less hazardous.



### Dust extraction

Standard connector (27/36/50 mm) for dust extraction to safeguard the operator and the environment.



### Electronic overload protection

Protects the motor with blocking tool.



### Turbo dust extraction

Turbo dust extraction ensures clean, dust-free air and a clear view of the workpiece.



### Groove in saw table

lever clamps on the saw table fix the workpiece securely and prevent it from shifting accidentally



### Electro-dynamic run-down brake