

**LIMITED WARRANTY (ONE YEAR)  
ON SIMPSON STRONG-TIE® BRAND TOOLS**

Simpson Strong-Tie Company Inc. ("Simpson") provides this limited warranty to original purchaser. This product, if properly used and maintained in compliance with all instructions and warnings, will be free from substantial defects in material and manufacturing for 1 year from purchase date. Purchaser's sole remedy is replacement upon return to Simpson within 1 year of purchase (shipping prepaid).



WHERE LAWFUL, SIMPSON DISCLAIMS ALL OTHER WARRANTIES, INCLUDING BUT NOT LIMITED TO IMPLIED WARRANTIES OF MERCHANTABILITY AND FITNESS FOR A PARTICULAR PURPOSE BEYOND THIS WARRANTY PERIOD. SOME STATES DO NOT ALLOW LIMITATIONS ON HOW LONG AN IMPLIED WARRANTY LASTS, SO THE ABOVE LIMITATION MAY NOT APPLY TO YOU. WHERE LAWFUL, UNDER NO CIRCUMSTANCES SHALL SIMPSON BE LIABLE FOR INCIDENTAL, CONSEQUENTIAL OR SPECIAL

DAMAGES OR DIRECT OR INDIRECT LOSS OF ANY KIND, INCLUDING BUT NOT LIMITED TO BODILY INJURY, DEATH OR PROPERTY DAMAGE. SIMPSON'S ENTIRE LIABILITY IS LIMITED TO THE PURCHASE PRICE OF THIS PRODUCT. SOME STATES DO NOT ALLOW THE EXCLUSION OR LIMITATION OF INCIDENTAL OR CONSEQUENTIAL DAMAGES, SO THE ABOVE LIMITATION OR EXCLUSION. MAY NOT APPLY TO YOU. SIMPSON IS IN NO WAY LIABLE FOR INCIDENTS RESULTING FROM USE WITHOUT PROPER CERTIFICATION OR DISREGARD OF INSTRUCTIONS AND WARNINGS. THIS LIMITED WARRANTY GIVES YOU SPECIFIC LEGAL RIGHTS, AND YOU MAY ALSO HAVE OTHER RIGHTS WHICH VARY FROM STATE TO STATE.



The PT-27 AND PT-25S tools comply with OSHA requirements and with ANSI A10.4 2007 specifications.

**Return Tools To:**

Northwest U.S.A.  
Simpson Strong-Tie Co., Inc.  
5151 S. Airport Way  
Stockton, CA 95206  
(209) 234-7775

Southwest U.S.A.  
Simpson Strong-Tie Co., Inc.  
260 N. Palm Street  
Brea, CA 92821  
(714) 871-8373

Northeast U.S.A.  
Simpson Strong-Tie Co., Inc.  
2600 International Street  
Columbus, OH 43228  
(614) 876-8060

Southeast U.S.A.  
Simpson Strong-Tie Co., Inc.  
2221 Country Lane  
McKinney, TX 75069  
(972) 542-0326

Eastern Canada  
Simpson Strong-Tie Co., Inc.  
5 Kenview Boulevard  
Brampton, ON L6T 5G5  
(905) 458-5538

Western Canada  
Simpson Strong-Tie Co., Inc.  
11476 Kingston Street  
Maple Ridge, BC V2X 0Y5  
(604) 465-0296

T-SAS-PT272507 6/07

© 2007 Simpson Strong-Tie Company Inc.

© 2007 Simpson Strong-Tie Company Inc.

**WARNING**

**Read This Manual  
BEFORE Operating This Tool**



**OPERATOR'S MANUAL**

**For Semiautomatic Tool Models**

**PT-27 and PT-25S**  
(.27 caliber)                      (.25 caliber)



## SAFETY STARTS WITH YOU

### A. TRAINING

1. All operators must complete the tool manufacturer's training before attempting to take an exam or to operate this Simpson tool. You must obtain certification of training from an authorized Simpson Strong-Tie® instructor. If such training is not available where you purchased the tool, call or write Simpson Strong-Tie before attempting to operate the tool for information on the nearest authorized instructor. Remember, obtaining this instruction is ***YOUR RESPONSIBILITY***.
2. Read this manual completely and understand its contents fully before attempting to operate the tool. If there is anything in this manual that you do not fully understand, ask your instructor or call Simpson Strong-Tie for information. Reading and understanding this manual is ***YOUR RESPONSIBILITY***.

### B. LIMITATIONS

1. Just as no instruction book of any kind can forewarn a learner against all possible situations or emergencies that may arise, neither can Simpson Strong-Tie instructors or printed instructions detail all possible conditions or circumstances surrounding the use of this tool or its supporting products. Recognizing these circumstances and reacting in a safe manner is ***YOUR RESPONSIBILITY***.
2. Simpson Strong-Tie disclaims any responsibility for injury or death, which may result from any disregard of this manual or the verbal instruction of the authorized Simpson Strong-Tie instructor. Following the rules of safe operation given to you here and verbally is ***YOUR RESPONSIBILITY***.

**SAFETY STARTS WITH YOU!!!  
OBTAIN AUTHORIZED TRAINING**

## PT-27 AND PT-25S TROUBLESHOOTING TIPS

Symptom	Cause	Solution
Over Driving Fasteners	Excessive Power	Change to next lower power level load strip.
	Soft Base Material	Check Base Material – Center Punch test.
Tool Does Not Fire	Tool not completely depressed	Firmly depress tool before firing
	Excessive dirt on chamber and breech	Properly clean the tool.
	Damaged firing pin or breech.	Replace damaged parts.
Reduction or loss of power	Piston is not returned to rear position	Barrel must be fully opened to reset piston
	Damaged piston or piston ring	Replace worn parts.
	Damaged piston stop	Replace damaged part.
Piston will not fully reset	Excess dirt	Completely clean the tool.
	Bent or damaged piston	Replace piston
Strip Load will not advance	Other damaged parts.	Tag the tool "Defective –Do not use". Place the tool in a locked container, and contact your local Simpson representative.
	Strip is inserted incorrectly	Check proper installation of strip
Strip Load will not advance	Advance mechanism is damaged	Contact your local Simpson representative. Tag the tool and lock it in a container.
	Tool will not stay in closed position	Ball bearing is missing

## PT-27 AND PT-25S KIT CONTENTS



© 2007 Simpson Strong-Tie Company, Inc.

© 2007 Simpson Strong-Tie Company, Inc.

## MAINTAINING AND CLEANING

### MAINTAINING THE PT-27 AND PT-25S TOOLS:

A clean tool always functions best. The PT-27 and PT-25S tools should be cleaned after each day of use or after 1,000 continuous fastenings.

A clean tool will:

- Help prevent the tool from accidentally discharging.
- Help maintain optimal power.
- Help prevent misfires (the tool not firing).

### CLEANING THE TOOLS:

With the provided lubricant and brushes, spray, brush, and wipe clean with a clean towel, the following parts:

- 1) Piston
- 2) Inside and outside of the Nosepiece, Baseplate and Barrel.  
Make certain the chamber end of the barrel is clean.
- 3) Inside the receiver.

Note: Make sure excess lubricant is wiped clean. Excessive lubricant can attract additional dirt.

### TOOL PARTS TO BE CLEANED:



## TABLE OF CONTENTS

Safety Starts with You.....	1
Introduction .....	2
General Handling of P.A.T. and Powder Loads.....	3
Making Safe Fastenings .....	4
The “No’s” of P.A.T. Fastening .....	5
Before Chambering a Powder Load.....	6
Safe Handling Practices of P.A.T.....	7
Operating Principles of P.A.T.....	8
Schematic and Parts for the PT-27 and PT-25S .....	9-10
Principles and Guidelines for Proper Fastening.....	11-12
How to Load and Fire the PT-27 and PT-25S .....	13-15
Dismantling the PT-27 and PT-25S .....	15-16
Maintaining and Cleaning .....	17
PT-27 and PT-25S Kit Contents.....	18
Troubleshooting Tips .....	18
Tool Warranty.....	Back Cover

## INTRODUCTION

The Simpson Strong-Tie® PT-27 and PT-25S tools are low velocity or indirect-acting powder actuated tools (P.A.T.). Do not attempt to operate either of these tools or any other tool before obtaining proper training and operator certification.

### READ THIS MANUAL CAREFULLY!

It will help you operate the tool with the greatest SAFETY and efficiency by providing you with an understanding of the safety features, operating principles and limitations of the tool and its use. Simpson Strong-Tie disclaims any responsibility for incidents resulting from the disregard of these instructions.

## GENERAL HANDLING OF P.A.T. AND POWDER LOADS

### GENERAL HANDLING OF THE PT-27, AND PT-25S, AND ALL P.A.T. TOOLS

1. **Always** point the tool away from yourself and all bystanders.
2. Open the tool before handling to make sure it is not loaded.
3. **Never** place your hand over the front (muzzle) of the tool.
4. **Never** operate the tool without checking to see if the barrel is free of obstructions and that the tool is clean and in good working condition.
5. **Never** attempt to alter, modify or manufacture parts for use in your Simpson Strong-Tie® tool, this can cause malfunctions and result in unsafe functioning of the tool. Use only genuine Simpson Strong-Tie parts, fasteners and powder loads at all times.
6. Operators and bystanders must wear eye and ear protection, and head protection is recommended. Serious injury or death can occur if these safety items are not used.
7. Posting a warning sign, "Warning, Powder Actuated Tool In Use" is a minimum warning where P.A.T. tools are in use.
8. **REMEMBER:** use common sense and good judgement. Use these tools for their intended purpose only. Know the material you are fastening into making certain it is compatible with the powder actuated tool.

### HANDLING THE PT-27 AND PT-25S, AND POWDER LOADS

1. **Never** carry powder loads in the same pocket or container with fasteners or any other hard objects.
2. **Never** use powder actuated loads in firearms. They are more powerful than normal small arms ammunition.
3. **Never** carry a loaded tool from job to job.
4. **Never** use the tool for anything other than its intended purpose.
5. **Never** use powder actuated tools in flammable atmospheres.
6. **Never** attempt to force a load into the chamber of the tool.
7. **Never** strike or pry a load.
8. **Always** wear eye and ear protection; head protection is recommended.
9. **Always** properly brace yourself when working on scaffolding or ladders.

## DISMANTLING THE PT-27 AND PT-25S TOOLS



3. Pull the barrel assembly out the front of the tool.



4. Lift and remove the Shear Clip from its recessed groove with a flat blade screw driver.



5. Separate the front barrel, baseplate and nosepiece.



6. Pull the piston out of the front of the barrel.

The front of the tool is now fully dismantled for cleaning, and inspection for any damaged parts. Completely clean the tool, and replace any damaged parts.

Reassemble the tool in reverse order of dismantling.

After reassembling the tool, with no load strip or fastener in the tool, reset the piston by pulling the barrel assembly completely out, then push it back in.

Press the tool against a hard surface and pull the trigger. The firing pin should make an audible "click" as an indication the tool was assembled properly and parts have proper functioning. If an audible "click" is not heard, reassemble the tool, and check for damaged parts and replace if necessary.

## HOW TO LOAD AND FIRE THE PT-27 AND PT-25S TOOLS



5. After making the fastening, lift the tool off the work surface and pull the nosepiece sharply forward, or flip the tool open with a snap of the wrist. This action resets the piston and advances the powder load strip to the next powder load.



6. Remove the spent powder strip load by grasping the strip from the top side of the tool and firmly pull upwards in a smooth motion.

## DISMANTLING THE PT-27 AND PT-25S TOOLS :



1. Rotate the annular spring off the piston stop with a flat blade screw driver or long fastener.



2. Lift the piston stop out of its recess slot.

## MAKING SAFE FASTENINGS

### BASE MATERIAL SUITABILITY & THE CENTER PUNCH TEST

Before loading the tool or fastening into any material, check the suitability and thickness of the base material. To check base material suitability, give it the center punch test.

### CENTER PUNCH TEST:

Using the fastener as a punch, with a hammer, strike a solid blow to the actual material you wish to fasten into, then look for these results:

1. If the point of the fastener is blunted, the material is too hard and is unsuitable. If the material is too hard, the fastener can ricochet, and possibly escape, striking you or bystanders and cause serious injury or death.
2. If the material cracks or shatters, it is too brittle and is unsuitable. This can result in particles striking the operator or bystanders, or the fastener could pass completely through the base material causing serious injury or death.
3. If the fastener sinks into the material with the hammer blow, the material is too soft and is unsuitable. If the material is too soft, the fastener can pass completely through and strike someone on the other side causing serious injury or death.
4. If the fastener makes a small indentation in the base the base material is suitable for fastening into.

### DO NOT USE POWDER ACTUATED TOOLS FOR FASTENING INTO THESE MATERIALS:

- |                           |                                 |
|---------------------------|---------------------------------|
| 1. Vertical mortar joints | 6. Hardened or tool grade steel |
| 2. Bricks                 | 7. Cast iron                    |
| 3. Hollow block or tile   | 8. Welded areas or torch cuts   |
| 4. Glazed tile            | 9. Spring steel                 |
| 5. Glass                  | 10. Natural rock                |

### BASE MATERIAL THICKNESS

Thickness of the base material is perhaps the most important consideration for good safe fastenings. In concrete, the thickness must be 3 times the shank penetration; in other words, for 1" of shank penetration, the concrete must be at least 3" thick. In steel the thickness must be equal to or greater than the diameter of the shank. Fastening into any base material, which is too thin, may allow the fastener to pass through and escape - resulting in serious injury or death.

## THE "NO'S" OF P.A.T. FASTENING

### GUIDELINES FOR SAFE FASTENING

1. **Never** Hold the tool at an acute angle to the work surface. The tool must be perpendicular to the work surface making certain that NO debris is present on the surface.
2. **Never** set a fastener too close to another installed fastener as this can cause a ricochet.
3. **Never** fasten less than 3" from the edge of unsupported concrete or masonry, or less than ½" from the edge of steel except for specific applications recommended by the tool manufacturer.
4. **Never** fasten into rough, spalled, cracked or uneven concrete. Fasten at least 3" from the outer edge of a spalled area.
5. **Never** fasten into material which is too hard, such as hardened steel, welds, cast steel, marble, spring steel, natural rock, etc. This could cause the fastener to shatter and escape and result in serious injury or death.
6. **Never** fasten into material which is too brittle, such as glass, glazed brick, glazed tile, slate, etc. This could cause the material to shatter and result in serious injury or death.
7. **Never** fasten into material which is too soft, such as wood, plaster, drywall composition board, plywood, etc. This could cause the fastener to pass through and escape resulting in serious injury or death.
8. **Never** fasten through an existing hole in any material as the fastener could hit the edge of the hole and ricochet.
9. **Never** leave the chamber loaded. If you decide not to make a fastening after having loaded the tool, remove both the powder load and fastener from the tool before returning it to its case.
10. **Never** place your hand or any part of your body over the muzzle, or point the tool toward any person when the tool is chambered with a load.

© 2007 Simpson Strong-Tie Company Inc.

## HOW TO LOAD AND FIRE THE PT-27 AND PT-25S TOOLS



3. Select the proper strip powder load and insert it through the bottom of the tool handle until it is flush with the bottom.



4. Depress the tool firmly against the work surface using both hands, then pull the trigger. Make certain you hold the tool perpendicular to the work. Using the supplied rubber spall stop will help ensure the tool is perpendicular to the work surface and will help to minimize concrete spalling when the fastener is installed.

© 2007 Simpson Strong-Tie Company Inc.

**WARNING: Always install the fastener in the tool first, and chamber the powder load last.**

## HOW TO LOAD AND FIRE THE PT-27 AND PT-25S TOOLS

Never place your hand over the nose of the tool unless inserting a fastener and then only with the chamber empty.

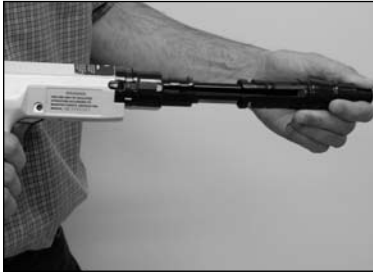

1. Open the tool. Grasp the nosepiece and pull sharply forward until you feel a positive stop, then pull the nosepiece back until it stops and is fully closed. This resets the piston and positions the advance lever in the correct location for inserting the strip loads.



2. Insert the fastener into the nosepiece of the tool, head or threaded end first. Push the fastener until the pointed end is even with the face of the nosepiece, or if a pre assembled fastener is used, until the nose piece is against the fastener accessory.



## BEFORE CHAMBERING A POWDER LOAD

### PREPARE FOR LOADING

1. **Always** open the tool and inspect it to be certain it is unloaded.
2. **Always** check to be sure that the tool is clean. Excessive dirt or debris can cause accidental firing or misfiring of the tool.
3. **Never** load or fire the tool in an explosive atmosphere or when flammables are nearby.
4. **Never** use improper powder loads or fasteners in the tool, as this may be unsafe or damage the tool.
5. **Always** insert the fastener first, and the load last. Make sure you never double load the fasteners.
6. **Never** allow bystanders to gather around you when using the tool.
7. **Never guess** - before fastening into any unknown base material, particularly into walls, perform the center punch test described in this manual.
8. **Never guess** - once you determine that the base material is suitable, make a test fastening with the lowest level powder load. If that powder load does not set the fastener, try the next highest load, and so on until the fastener is properly set.

### SELECTING FASTENERS AND LOADS

#### .27 caliber strip loads for PT-27:

Simpson Strong-Tie® Part #	Power Level	Color
P27SL2	2 (low)	Brown
P27SL3	3	Green
P27SL4	4	Yellow
P27SL5	5 (high)	Red

#### .25 caliber strip loads for PT-25S:

Simpson Strong-Tie® Part #	Power Level	Color
P25SL3	3 (low)	Green
P25SL4	4	Yellow
P25SL5	5 (high)	Red

#### Fasteners for the PT-27 and PT-25S:

Simpson Strong-Tie Fasteners	Description	PT-27	PT-25S
PDP-XXX	.300 Headed	2-1/2" max	1-1/2" max
PDPW-XXX	.300 Headed w/ 3/4" washer	all	2" max
PDPWL-XXX	.300 Headed w/ 1" washer	all	2" Max
PINWP-XXX	.300 Headed w/ 1-3/8" plastic washer	2-1/2" max	1-1/2" max
PINW-XXX	.300 headed w/ 1-7/16" washer	all	2" max
PHN-XXX	8 mm Headed	2-1/2" max	1-1/2" max
PHNW-XXX	8 mm Headed w/ 1" washer	all	2" max
PSLV4-XXXXX	1/4"-20 Threaded Stud	all	1-1/2" max
PDPT-XXX	.300 headed Tophat	all	all
PHCB-XXX	.300 headed highway basket clip	2-1/2" max	1-1/2" max
PBXP-XXX	.300 headed BX cable strap	all	all
PECLDP-XXX	.300 heaed ceiling clips	all	all
PCCXXX-DPXXX	.300 headed conduit clips	all	all

## SAFE HANDLING PRACTICES OF P.A.T.

1. If the powder load does not fire after pulling the trigger, hold the tool firmly against the work surface for at least 30 seconds. Carefully remove the tool from the work surface, making sure to point it away from yourself and any bystanders. Remove the load and dispose of it in a can of water. Unfired loads must never be thrown in trash containers or carelessly discarded in any way.
2. **NEVER** attempt to force or pry an unfired powder load from the chamber with a sharp or pointed object, as this may cause an accidental discharge.
3. **NEVER** attempt to disassemble a jammed tool containing a live powder load. Tag the tool "DO NOT USE" and store it safely in a locked case. Call your Simpson Strong-Tie® representative for tool repair.
4. If at any time during the operation of the tool you feel it is not working properly, STOP using it and call your Simpson Strong-Tie representative.
5. If unnecessary bystanders are in the area tell them to leave, warn all others that you are using a powder actuated tool.
6. Check the work surface to be sure it is clear of any debris. Clear away any debris so that the tool sits flush on the work surface.
7. Check the work area for explosive or flammable materials. If any are found remove them before operating the tool.
8. Check the chamber of the tool to be sure there is no dirt, grit or foreign objects present.
9. Check the barrel to make sure you don't double load it with fasteners, and that it is clear of any obstruction.
10. Any tool found not to be in proper working condition shall be immediately removed from service and tagged "Defective Tool", until it has been repaired according to manufacturer's instructions.

BEFORE loading the tool, operate it a few times on a solid surface making certain all parts move freely and that the firing pin clicks when the tool is fully depressed and the trigger is pulled. "Dry firing" will not damage the tool.

## PRINCIPLES AND GUIDELINES FOR PROPER FASTENING

### FISH-HOOKING:

"Fish-hooking" is when the fastener curves when driven into concrete. This is caused by the fastener hitting large, hard, or excessive amounts of aggregate, rebar, or any hard object. Fish-hooking can reduce the holding power of the fastener, result in spalling, and may increase unsafe conditions due to escaping particles. Fish-hooking can be minimized by:

- Reducing shank penetration
- Increasing shank diameter
- Using appropriate powder load level. Excessive power can cause over driving.
- Fastening through a metal disc

### FASTENING INTO STEEL:

The most common type of steel fastened into is structural steel in the form of beam, angle iron, channel, tee, plate, and strip. The holding power of the powder actuated fastener is a function of the gripping action of the steel base material around the fastener, and the fusion of the fastener to the base material.

### FACTORS THAT INFLUENCE THE HOLDING POWER OF FASTENERS IN STEEL ARE:

- Shank diameter: Larger shank diameters increase holding power
- Thickness of steel base material: Thicker base material increases holding power
- Fastener Point Penetration: Getting the point to pass through base material by approximately ¼" maximizes holding power
- Knurled Fasteners: Knurling on the fastener provides interlocking of the shank and the base material which increases the holding power

### GENERAL RULES:

Minimum spacing of fasteners into steel is 1½". Minimum edge distance of fasteners into steel is ½". Steel Thickness must be no less than the shank diameter of the fastener.



## PRINCIPLES AND GUIDELINES FOR PROPER FASTENING

### FASTENING INTO MASONRY MATERIALS:

Masonry materials suitable for fastening into include:

- Poured concrete
- Precast concrete
- Pre-stressed concrete
- Grout filled concrete block
- Grouted joints

Fasteners are primarily held into masonry by a clamping of the concrete around the fastener. Factors that influence a fastener driven into concrete include:

- Depth of penetration
- Compressive strength of concrete
- Fastener spacing and edge distance
- Fastener shank diameter
- Concrete aggregate

### PROPER DEPTH OF PENETRATION:

	.145" Dia. Shank Penetration	¼" Stud Penetration
Concrete Block & Joints	1"-1¼"	1½"-1¾"
Concrete 2000-2500 psi	9-10 times Shank Dia. or 1¼" -1½"	1"-1½"
Concrete 2500-4000 psi	7-8 times shank Dia. or 1"-1¼"	1"-1½"
Precast or prestressed concrete 4,000 psi	5-6 times shank Dia. or ¾"-1¼"	¾"-1"

### FASTENER EDGE DISTANCE ON CONCRETE:

Distance should be no closer than 3".

### MINIMUM DISTANCE BETWEEN FASTENINGS:

.300 and 8 mm headed fasteners – 3" spacing.  
¼" and ⅜" threaded fasteners – 6" spacing.

### CONCRETE THICKNESS:

Concrete thickness must be at least 3 times the fastener penetration.

## OPERATING PRINCIPLES OF P.A.T.

### THERE ARE TWO TYPES OF POWDER ACTUATED TOOLS:

#### INDIRECT-ACTING TYPE TOOL

Indirect-acting type tools work by expanding gases that act directly on a piston which drives the piston forward to strike the fastener.

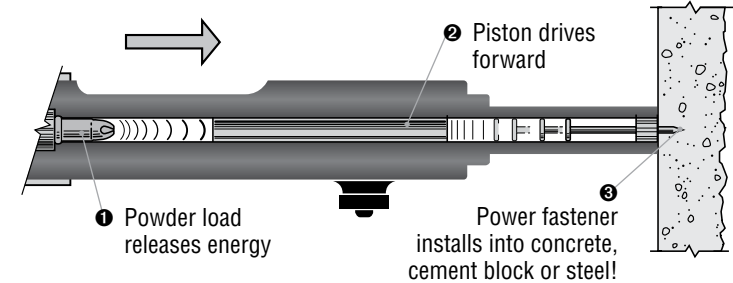

The PT-27 and PT-25S are indirect-acting type tools.

#### DIRECT-ACTING TYPE TOOL

Direct-acting type tools work by expanding gases that act directly on the fastener without the use of a piston. Direct-acting tools are no longer manufactured in North America and are regarded as far less safe to operate than indirect-acting tools.

**CAUTION:** Powder actuated tools are capable of fastening into concrete and/or steel. The fastener enters the work surface with an extreme amount of energy. Make certain not to misdirect the energy.

### SAFETY STARTS WITH YOU!

As the powder actuated tool operator, your safety and the safety of those around you should always be kept in mind. Consider that the least powerful load used in powder actuated tools produce approximately 10 times the power of a .22 caliber long rifle cartridge. Respect this power as you would a chain saw, a lawn mower, or a rifle.

## SCHEMATIC AND PARTS FOR THE PT-27 AND PT-25S TOOLS

### PT-25S

1. Body Assembly	PT-035001
8. Receiver	PT-035100
9. Annular Spring	PT-035014
11. Piston Stop	PT-035012
15. Barrel	PT-035006
16. Piston Flat	PT-035903
16a Piston-Concave	PT-035217
18. Nose Piece	PT-035010
19. Baseplate	PT-035009

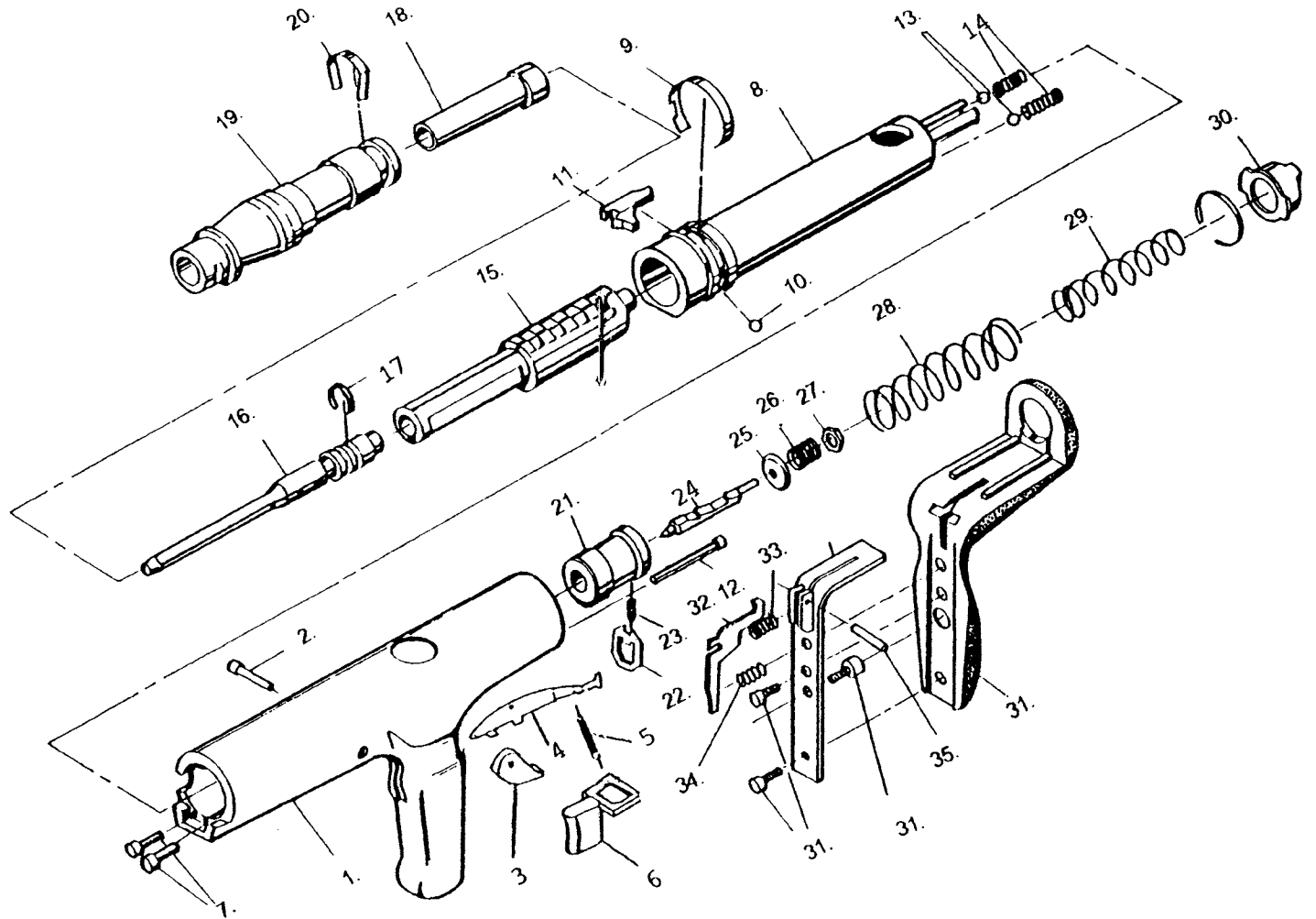

### PT-27 and PT-25S

1. Body Assem.	PT-301001	11. Piston Stop	PT-301012	19. Baseplate	PT-301009	28. Spring	PT-301026
2. Trigger Pin	PT-301034	12. Push Pin	PT-301016	20. Shear Clip	PT-301011	(Sear Holder)	
3. Advance Bar Hold	PT-301529	13. Ball Bearing (5mm)	PT-301046	21. Sear Holder	PT-301300	29. Spring	PT-301025
4. Advance Bar	PT-301530	14. Spring (Mag catch)	PT-301047	22. Sear	PT-301023	(firing pin)	
5. Advance Bar Spr.	PT-301531	15. Barrel	PT-301006	23. Sear Spring	PT-301024	30. Plug	PT-301028
6. Trigger	PT-301533	16. Piston Flat	PT-301903	24. Firing Pin Assem	PT-301904	31. Rubber Pad	PT-301601
7. Screw (bolt)	PT-301015	(incl. piston & ring)		25. Spring Holder	PT-301420	32. Rock Arm	PT-301844
8. Receiver	PT-301100	16a Piston Concave	PT-301217	26. Spring	PT-301421	33. Spring (lever)	PT-301840
9. Annular Spring	PT-301014	17. Piston Ring	PT-301208	(Firing pin return)		34. Spring (trigger)	PT-301843
10. Ball Bearing (6mm)	PT-301013	18. Nose Piece	PT-301010	27. Nut	PT-301422	35. Pin, Rock Arm	PT-301845