

**MAX**

# ***SuperFramer™***

**SN883RH3**

**SN890CH3/34**

**SN883CH2/28**

PNEUMATIC NAILER

CLOUEUSE PNEUMATIQUES

CLAVADORAS NEUMATICAS  
PARA PEINES DE CLAVO

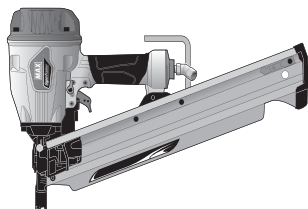

SN883RH3

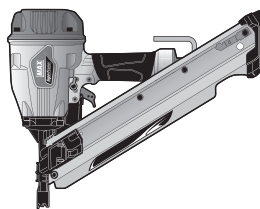

SN890CH3/34

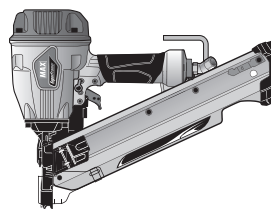

SN883CH2/28

## **OPERATING AND MAINTENANCE MANUAL MANUEL D'UTILISATION ET D'ENTRETIEN MANUAL DE OPERACIONES Y MANTENIMIENTO**



**WARNING**

BEFORE USING THIS TOOL, STUDY THIS MANUAL TO ENSURE SAFETY WARNING AND INSTRUCTIONS.  
KEEP THESE INSTRUCTIONS WITH THE TOOL FOR FUTURE REFERENCE.



**AVERTISSEMENT**

AVANT D'UTILISER CET OUTIL, LIRE CE MANUEL ET LES CONSIGNES DE SÉCURITÉ AFIN DE GARANTIR UN FONCTIONNEMENT SÛR.  
CONSERVER CE MANUEL EN LIEU SÛR AVEC L'OUTIL AFIN DE POUVOIR LE CONSULTER ULTÉRIEUREMENT.



**ADVERTENCIA**

ANTES DE UTILIZAR ESTA HERRAMIENTA, LEA DETENIDAMENTE ESTE MANUAL PARA FAMILIARIZARSE CON LAS ADVERTENCIAS E INSTRUCCIONES DE SEGURIDAD.  
CONSERVE ESTAS INSTRUCCIONES JUNTO CON LA HERRAMIENTA PARA FUTURAS CONSULTAS.

# INDEX INDEX ÍNDICE

<b>ENGLISH</b>	<b>Page</b>	<b>3</b>	<b>to</b>	<b>18</b>
<b>FRANÇAIS</b>	<b>Page</b>	<b>19</b>	<b>to</b>	<b>34</b>
<b>ESPAÑOL</b>	<b>Page</b>	<b>35</b>	<b>to</b>	<b>50</b>

## **DEFINITIONS OF SIGNAL WORDS**

<b>WARNING:</b>	Indicates a potentially hazardous situation which, if not avoided, could result in death or serious injury.
<b>CAUTION:</b>	Indicates a potentially hazardous situation which, if not avoided, may result in minor or moderate injury.
<b>NOTICE:</b>	Emphasizes essential information.

## **DÉFINITIONS DES DIFFÉRENTS DEGRÉS D' AVERTISSEMENTS**

<b>AVERTISSEMENT</b>	Indique une situation éventuellement dangereuse qui, si elle n'est pas contournée, pourrait provoquer la mort ou des blessures sérieuses.
<b>ATTENTION</b>	Indique une situation éventuellement dangereuse qui, si elle n'est pas contournée, pourrait provoquer des blessures légères à moyennement sérieuses.
<b>REMARQUE</b>	Souligne des informations importantes.

## **DEFINICIÓN DE LAS INDICACIONES DE ADVERTENCIA**

<b>!ATENCIÓN!</b>	Indica una situación potencialmente peligrosa que podría causar la muerte o graves lesiones si no se evita.
<b>!PRECAUCIÓN!</b>	Indica una situación potencialmente peligrosa que podría causar lesiones menos graves o leves si no se evita.
<b>NOTA:</b>	Resalta informaciones importantes.

# ENGLISH

## OPERATING AND MAINTENANCE MANUAL

### INDEX

1. SAFETY INSTRUCTIONS .....	3
2. SPECIFICATIONS AND TECHNICAL DATA .....	7
3. AIR SUPPLY AND CONNECTIONS .....	9
4. INSTRUCTIONS FOR OPERATION .....	10
5. MAINTENANCE FOR PERFORMANCE .....	18
6. STORAGE .....	18
7. TROUBLE SHOOTING/REPAIRS.....	18



**WARNING**

BEFORE USING THIS TOOL, STUDY THIS MANUAL TO ENSURE SAFETY WARNING AND INSTRUCTIONS. KEEP THESE INSTRUCTIONS WITH THE TOOL FOR FUTURE REFERENCE.

### 1. SAFETY INSTRUCTIONS



**WARNING**

#### **TO AVOID SEVERE PERSONAL INJURY OR PROPERTY DAMAGE**

BEFORE USING THE TOOL, READ CAREFULLY AND UNDERSTAND THE FOLLOWING "SAFETY INSTRUCTIONS". FAILURE TO FOLLOW WARNINGS COULD RESULT IN DEATH OR SERIOUS INJURY.

### PRECAUTIONS ON USING THE TOOL



#### **1. WEAR SAFETY GLASSES OR GOGGLES**

Danger to the eyes always exists due to the possibility of dust being blown up by the exhausted air or of a fastener flying up due to the improper handling of the tool. For these reasons, safety glasses or goggles shall always be worn when operating the tool.

The employer and/or user must ensure that proper eye protection is worn. Eye protection equipment must conform to the requirements of the American National Standards Institute, ANSI Z87.1 (Council Directive 89/686/EEC of 21 DEC. 1989) and provide both frontal and side protection.

The employer is responsible to enforce the use of eye protection equipment by the tool operator and all other personnel in the work area.

**NOTE:** Non-side shielded spectacles and face shields alone do not provide adequate protection.



**2. EAR PROTECTION MAY BE REQUIRED IN SOME ENVIRONMENTS**

As the working condition may include exposure to high noise levels which can lead to hearing damage, the employer and user should ensure that any necessary hearing protection is provided and used by the operator and others in the work area.



**3. DO NOT USE ANY POWER SOURCE EXCEPT AN AIR COMPRESSOR**

The tool is designed to operate on compressed air. Do not operate the tool on any other highpressure gas, combustible gases (e.g., oxygen, acetylene, etc.) since there is the danger of an explosion. For this reason, absolutely do not use anything other than an air compressor to operate the tool.



**4. OPERATE WITHIN THE PROPER AIR PRESSURE RANGE**

The tool is designed to operate within an air pressure range of 70 to 100 p.s.i. (5 to 7 bar). The pressure should be adjusted to the type of the work being fastened. The tool shall never be operated when the operating pressure exceeds 120 p.s.i. (8 bar). Never connect the tool to air pressure which potentially exceeds 200 p.s.i. (14 bar) as the tool can burst.

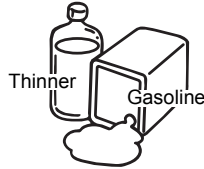

**5. DO NOT OPERATE THE TOOL NEAR A FLAMMABLE SUBSTANCE**

Never operate the tool near a flammable substance (e.g., thinner, gasoline, etc.). Volatile fumes from these substances could be drawn into the compressor and compressed together with the air and this could result in an explosion.

**6. NEVER USE THE TOOL IN AN EXPLOSIVE ATMOSPHERE**

Sparks from the tool may ignite atmospheric gases, dust or other combustible materials.

**7. DO NOT USE A WRONG FITTINGS**

The connector on the tool must not hold pressure when air supply is disconnected. If a wrong fitting is used, the tool can remain charged with air after disconnecting and thus will be able to drive a fastener even after the air line is disconnected, possibly causing injury.



**8. DISCONNECT THE AIR SUPPLY AND EMPTY THE MAGAZINE WHEN THE TOOL IS NOT IN USE**

Always disconnect the air supply from the tool and empty the magazine when operation has been completed or suspended, when unattended, moving to a different work area, adjusting, disassembling, or repairing the tool, and when clearing a jammed fastener.



### 9. INSPECT SCREW TIGHTNESS

Loose or improperly installed screws or bolts cause accidents and tool damage when the tool is put into operation. Inspect to confirm that all screws and bolts are tight and properly installed prior to operating the tool.



### 10. DO NOT TOUCH THE TRIGGER UNLESS YOU INTEND TO DRIVE A FASTENER

Whenever the air supply is connected to the tool, never touch the trigger unless you intend to drive a fastener into the work. It is dangerous to walk around carrying the tool with the trigger pulled, and this and similar actions should be avoided.



### 11. NEVER POINT THE DISCHARGE OUTLET TOWARD YOURSELF AND OTHER PERSONNEL

If the discharge outlet is pointed toward people, serious accidents may be caused when misfiring. Be sure the discharge outlet is not pointed toward people when connecting and disconnecting the hose, loading and unloading the fasteners or similar operations.

### 12. USE SPECIFIED FASTENERS (SEE PAGE 7)

The use of fasteners other than specified fasteners will cause the tool malfunction. Be sure to use only specified fasteners when operating the tool.

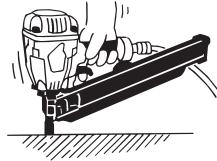

### 13. PLACE THE DISCHARGE OUTLET ON THE WORK SURFACE PROPERLY

Failure to place the discharge outlet of the nose in a proper manner can result in a fastener flying up and is extremely dangerous.

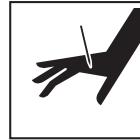

### 14. KEEP HANDS AND BODY AWAY FROM THE DISCHARGE OUTLET

When loading and using the tool, never place a hand or any part of body in fastener discharge area of the tool. It is very dangerous to hit the hands or body by mistake.



### 15. DO NOT DRIVE FASTENERS CLOSE TO THE EDGE AND CORNER OF THE WORK AND THIN MATERIAL

The workpiece is likely to split and the fastener could fly free and hit someone.



**16. DO NOT DRIVE FASTENERS ON TOP OF OTHER FASTENERS**

Driving fasteners on the top of other fasteners may cause deflection fasteners which could cause injury.

**17. REMOVING THE FASTENERS AFTER COMPLETING OPERATION**

If fasteners are left in the magazine after the completion of operation, there is the danger of a serious accident occurring prior to the resumption of operation, should the tool be handled carelessly, or when connecting the air fitting. For this reason, always remove all fasteners remaining in the magazine after completion of the operation.

**18. CHECK OPERATION OF THE CONTACT TRIP MECHANISM FREQUENTLY IN CASE OF USING A CONTACT TRIP TYPE TOOL**

Do not use the tool if the trip is not working correctly as accidental driving of a fastener may result. Do not interfere with the proper operation of the contact trip mechanism.

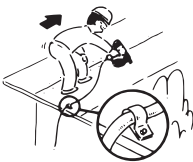

**19. WHEN USING THE TOOL OUTSIDE OR ELEVATED PLACE**

When fastening roofs or similar slanted surface, start fastening at the lower part and gradually work your way up. Fastening backward is dangerous as you may lose your foot place.

Secure the hose at a point close to the area you are going to drive fasteners. Accidents may be caused due to the hose being pulled inadvertently or getting caught.

**20. NEVER USE THE TOOL IF ANY PORTION OF THE TOOL CONTROLS (e.g., TRIGGER, CONTACT ARM) IS INOPERABLE, DISCONNECTED, ALTERED OR NOT WORKING PROPERLY**

**21. NEVER ACTUATE THE TOOL INTO FREE SPACE**

This will avoid any hazard caused by free flying fasteners and excessive strain of the tool.

**22. ALWAYS ASSUME THAT THE TOOL CONTAINS FASTENERS**

**23. RESPECT THE TOOL AS A WORKING IMPLEMENT**

**24. NO HORSEPLAY**

**25. NEVER LOAD THE TOOL WITH FASTENERS WHEN ANY ONE OF THE OPERATING CONTROLS (e.g., TRIGGER, CONTACT ARM) IS ACTIVATED**

**26. WHEN DISPOSING THE MACHINE OR ITS PARTS, FOLLOW THE RELEVANT NATIONAL RULES**

---

**OBSERVE THE FOLLOWING GENERAL CAUTION IN ADDITION TO THE OTHER WARNINGS CONTAINED IN THIS MANUAL**

- Always wear head protection, safety shoes and mask when using the tool.
- Do not use the tool as a hammer.
- Always carry the tool by the grip, never carry the tool by the air hose.
- The tool must be used only for the purpose it was designed.
- Never remove, tamper with the operating controls (e.g., TRIGGER, CONTACT ARM)
- Keep the tool in a dry place out of reach of children when not in use.
- Do not use the tool without Safety Warning label.
- Do not modify the tool from original design or function without approval by MAX CO., LTD.

## 2. SPECIFICATIONS AND TECHNICAL DATA

### 1. NAME OF PARTS

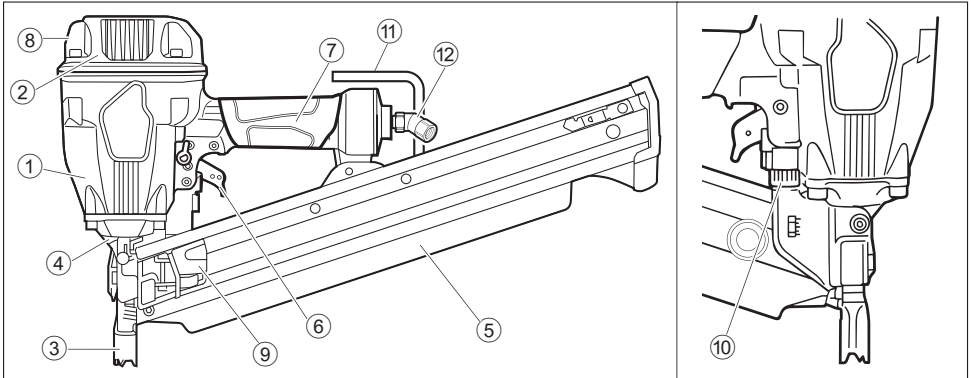

- |                |                   |                |
|----------------|-------------------|----------------|
| ① Frame        | ⑥ Trigger         | ⑪ Rafter Hook  |
| ② Cylinder Cap | ⑦ Grip            | ⑫ Swivel Joint |
| ③ Contact Arm  | ⑧ Exhaust Cover   |                |
| ④ Nose         | ⑨ Pusher          |                |
| ⑤ Magazine     | ⑩ Adjustment Dial |                |

### 2. TOOL SPECIFICATIONS

PRODUCT NO.	SN883RH3	SN890CH3/34	SN883CH2/28
HEIGHT	11-7/8" (300 mm)	12-1/2" (316 mm)	12-1/4" (310 mm)
WIDTH	4-3/4" (121 mm)	4-3/4" (121 mm)	4-3/4" (121 mm)
LENGTH	20-3/4" (526 mm)	17-1/8" (435 mm)	16-7/8" (428 mm)
WEIGHT	7.9 lbs (3.6 kg)	8.0 lbs (3.6 kg)	7.8 lbs (3.5 kg)
RECOMMENDED OPERATING PRESSURE	70 to 100 p.s.i. (5 to 7 bar)		
LOADING CAPACITY	64 nails	90 nails	
AIR CONSUMPTION	0.077 ft <sup>3</sup> at 90 p.s.i. (2.1 ℓ at 6 bar) operating pressure		

### 3. FASTENER SPECIFICATIONS

PRODUCT NO.	SN883RH3	SN890CH3/34	SN883CH2/28
NAIL LENGTH	2" to 3-1/4" (50 to 83 mm)	2" to 3-1/2" (50 to 90 mm)	2" to 3-1/4" (50 to 83 mm)
SHANK DIAMETER	.113" to .148" (2.9 to 3.8 mm)	.113" to .131" (2.9 to 3.3 mm)	
SHANK TYPE	Smooth, Ring, Screw		
HEAD DIAMETER	.267" to .295" (6.8 to 7.5 mm)	.256" to .303" (6.5 to 7.7 mm)	
COLLATION ANGLE	21 degree	34 degree	28 degree
HEAD	Full round head	Offset/Clipped head	

## TOOL AIR FITTINGS:

This tool uses a 3/8" N.P.T. male plug. The inside diameter should be .39" (9.9mm) or larger. The fitting must be capable of discharging tool air pressure when disconnected from the air supply.

## RECOMMENDED OPERATING PRESSURE:

70 to 100 p.s.i. (5 to 7 bar). Select the operating air pressure within this range for best fastener performance.

**DO NOT EXCEED 120 p.s.i. (8 bar).**

## 4. TECHNICAL DATA

### 1 NOISE

A-weighted single-event sound power level  
----- LWA, 1s, d 101.03 dB  
(SN883RH3, SN883CH2/28)  
----- LWA, 1s, d 96.9 dB  
(SN890CH3/34)

A-weighted single-event emission sound pressure level at work station  
----- LpA, 1s, d 92.72 dB  
(SN883RH3, SN883CH2/28)  
----- LpA, 1s, d 86.5 dB  
(SN890CH3/34)

These values are determined and documented in accordance to EN12549 : 1999.



### 2 VIBRATION

Vibration characteristic value  
= 4.26 m/s<sup>2</sup> (SN883RH3)  
= 4.5 m/s<sup>2</sup> (SN890CH3/34)  
= 3.84 m/s<sup>2</sup> (SN883CH2/28)

These values are determined and documented in accordance to ISO 8662-11.

This value is a tool-related characteristic value and does not represent the influence to the hand-arm-system when using the tool. An influence to the hand-arm-system when using the tool will for example depend on the gripping force, the contact pressure force, the working direction, the adjustment of mains supply, the workpiece, the workpiece support. The above vibration measurement were recorded with the Black Trigger.

## 5. APPLICATIONS

- \* Floor and wall framing
- \* Subflooring
- \* Roof and wall sheathing
- \* Fencing



### 3. AIR SUPPLY AND CONNECTIONS



**WARNING**

#### READ SECTION TITLED "SAFETY INSTRUCTIONS"



#### DO NOT USE ANY POWER SOURCE EXCEPT AN AIR COMPRESSOR

The tool is designed to operate on compressed air. Do not operate the tool on any other high-pressure gas, combustible gases (e.g., oxygen, acetylene, etc.) since there is the danger of an explosion. For this reason, absolutely do not use anything other than an air compressor to operate the tool.



#### OPERATE WITHIN THE PROPER AIR PRESSURE RANGE

The tool designed to operate within an air pressure range of 70 to 100 p.s.i. (5 to 7 bar). The pressure should be adjusted to the type of the work being fastened. The tool shall never be operated when the operating pressure exceeds 120 p.s.i. (8 bar).

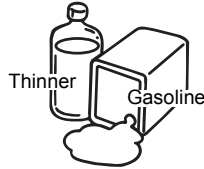

#### DO NOT OPERATE THE TOOL NEAR A FLAMMABLE SUBSTANCE

Never operate the tool near a flammable substance (e.g., thinner, gasoline, etc.). Volatile fumes from these substances could be drawn into the compressor and compressed together with the air and this could result in an explosion.

#### DO NOT USE A WRONG FITTINGS

The connector on the tool must not hold pressure when air supply is disconnected. If a wrong fitting is used, the tool can remain charged with air after disconnecting and thus will be able to drive a fastener even after the air line is disconnected, possibly causing injury.



#### DISCONNECT THE AIR SUPPLY AND EMPTY THE MAGAZINE WHEN THE TOOL IS NOT IN USE

Always disconnect the air supply from the tool and empty the magazine when operation has been completed or suspended, when unattended, moving to a different work area, adjusting, disassembling, or repairing the tool, and when clearing a jammed fastener.

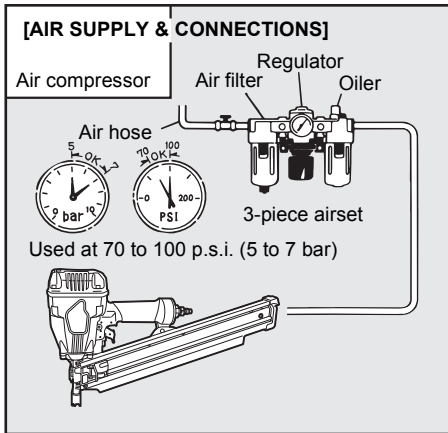

**FITTINGS:** Install a male plug on the tool which is free flowing and which will release air pressure from the tool when disconnected from the supply source.

**HOSES:** Hose has a min. ID of 1/4" (6 mm) and max. length of no more than 17" (5 meters). The supply hose should contain a fitting that will provide "quick disconnecting" from the male plug on the tool.

**SUPPLY SOURCE:** Use only clean regulated compressed air as a power source for the tool.

**3-PIECE AIRSET** (Air filter, Regulator, Oiler): Refer to TOOL SPECIFICATIONS for setting the correct operating pressure for the tool.

**NOTE:**

A filter will help to get the best performance and minimum wear from the tool because dirt and water in the air supply are major causes of wear in the tool.

Frequent, but not excessive, lubrication is required for the best performance. Oil added thru the air line connection will lubricate the internal parts.

## 4. INSTRUCTIONS FOR OPERATION

### READ SECTION TITLED "SAFETY INSTRUCTIONS".

#### 1. BEFORE OPERATION (Check the following prior operation)

Check the following prior operation.

- ① Wear Safety Glasses or Goggles.
- ② Do not connect the air supply.
- ③ Inspect screw tightness.
- ④ Check operation of the contact arm & trigger if it moves smooth.
- ⑤ Connect the air supply.
- ⑥ Check the air-leakage. (The Tool must not have the air-leakage.)
- ⑦ Hold the Tool without putting the finger on the trigger, then push the contact arm against the workpiece. (The tool must not operate.)
- ⑧ Hold the Tool with contact arm free from workpiece and pull the trigger. (The Tool must not operate.)
- ⑨ Disconnect the air supply.



**WARNING**



#### 2. OPERATION

Wear safety glasses or goggles danger to the eyes always exists due to the possibility of dust being blown up by the exhausted air or of a fastener flying up due to the improper handling of the tool. For these reasons, safety glasses or goggles shall always be worn when operating the tool.

The employer and/or user must ensure that proper eye protection is worn. Eye protection equipment must conform to the requirements of the American National Standards Institute, ANSI Z87.1 (Council Directive 89/686/EEC of 21 DEC. 1989) and provide both frontal and side protection.

The employer is responsible to enforce the use of eye protection equipment by the tool operator and all other personnel in the work area.

**NOTE:** Non-side shielded spectacles and face shields alone do not provide adequate protection.



## WARNING



Keep hands and body away from the discharge outlet when driving the fasteners because of dangerous of hitting the hands or body by mistake.

## NAIL LOADING



### WARNING

- When loading the nails, be sure to release the finger from the Trigger.
- Do not press the Contact Arm against the object.

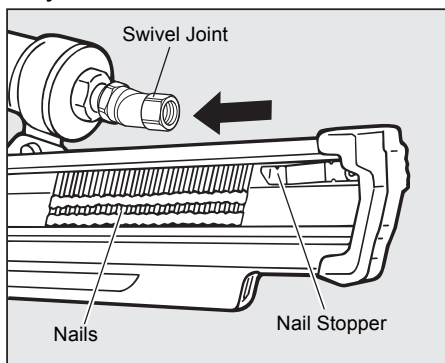

## PROCEDURE

- ① Load the nails into the slot in the rear of the Magazine until they go over the Nail Stopper.

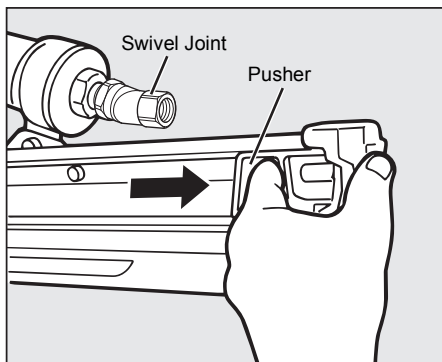

- ② Pull the Pusher as far as the rear end of the magazine and release it gently.



## CAUTION

**Abrupt release of the Pusher causes jamming of nails or dry-firing.**

## TEST OPERATION

- ① Adjust the air pressure at 70 p.s.i. (5 bar) and connect the air supply.
- ② Without touching the trigger, depress the contact arm against the workpiece. Pull the trigger. (The tool must fire the fastener.)
- ③ With the tool off the workpiece, pull the trigger. Then depress the contact arm against the workpiece. (The tool must fire the fastener.)
- ④ Adjust the air pressure as much as the lowest possible according the length of fastener and the hardness of workpiece.

## DRIVING FASTENERS

### NOTE:

This tool is shipped with SEQUENTIAL TRIP selected.



### WARNING

- To avoid double firing or accidental firing, pull the trigger rapidly and firmly.

### SEQUENTIAL TRIP

The Sequential Trip requires the operator to hold the tool against the work before pulling the trigger. This makes accurate fastener placement easier, for instance on framing, toe nailing and crating applications. The Sequential Trip allows exact fastener location without the possibility of driving a second fastener on recoil, as described under "Contact Trip".

The Sequential Trip Tool has a positive safety advantage because it will not accidentally drive a fastener if the tool is contacted against the workpiece or anything else while the operator is holding the trigger pulled.

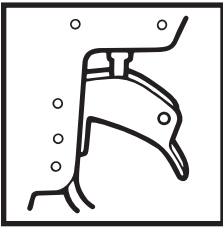

### SEQUENTIAL TRIP

Identified by **ORANGE TRIGGER**.

### CONTACT TRIP

The common operating procedure on "Contact Trip" tools is for the operator to contact the work to actuate the trip mechanism while keeping the trigger pulled, thus driving a fastener each time the work is contacted. This will allow rapid fastener placement on many jobs, such as sheathing, decking and pallet assembly. All pneumatic tools are subject to recoil when driving fasteners. The tool may bounce, releasing the trip, and if unintentionally allowed to recontact the work surface with the trigger still actuated (finger still holding trigger pulled) an unwanted second fastener will be driven.

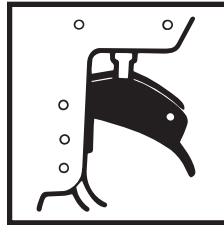

### CONTACT TRIP

Identified by **BLACK TRIGGER**

## SWITCHING SEQUENTIAL TRIP TO CONTACT TRIP

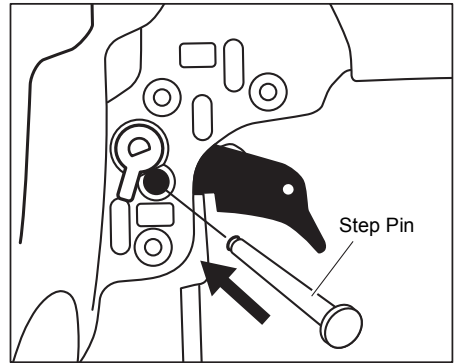
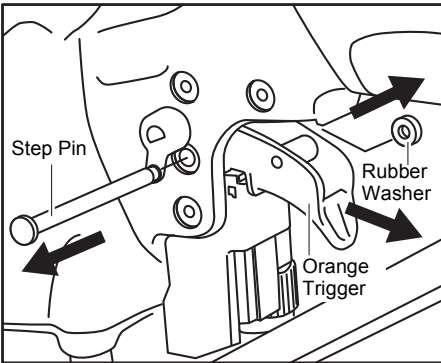
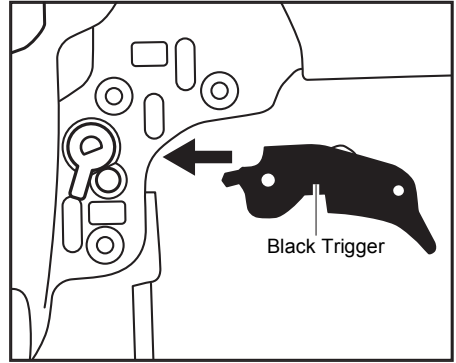
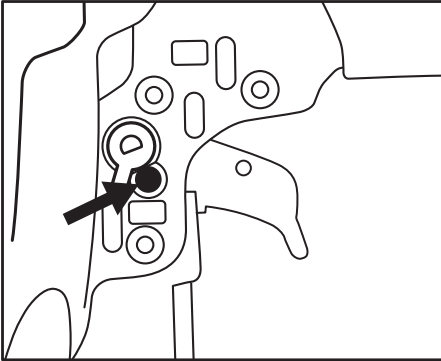

### WARNING

- **ALWAYS** disconnect air supply before switching the triggering method.
- ① Push out the Step Pin, and remove the Rubber Washer and the Orange Trigger.

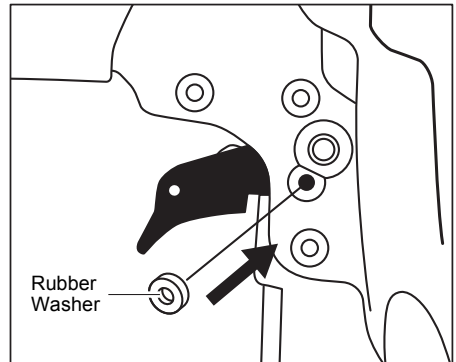

- ② Attach the Black Trigger to the tool. Pass the Step Pin through the hole, and secure it with the Rubber Washer.

### NOTE:

When switching from CONTACT TRIP to SEQUENTIAL TRIP, reassemble the Orange Trigger in the reverse order.

## DRIVING FASTENERS

### 1. SINGLE FIRE OPERATION (SEQUENTIAL TRIP)

For single fire operation, activate workpiece contact against work surface and pull trigger. A fastener will be driven. Release both trigger and workpiece contact. Begin again.

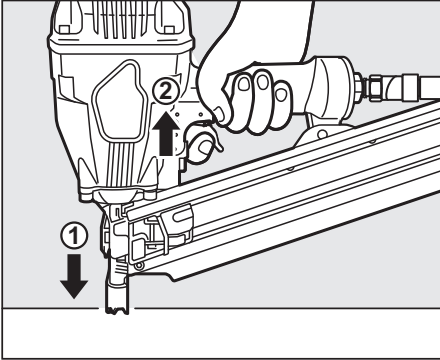

#### PROCEDURE

- ① Depress the Contact Arm.
- ② Pull the Trigger.

### 2. CONTACT FIRE OPERATION

For contact fire operation, hold the Trigger and depress the Contact Arm against the work surface.

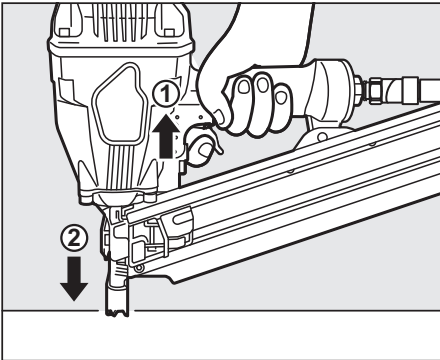

#### PROCEDURE

- ① Hold the Trigger.
- ② Depress the Contact Arm.

## MODEL IDENTIFICATION

Identified by TRIGGER's COLOR.

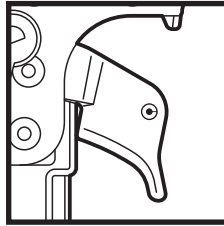

SEQUENTIAL TRIP	CONTACT TRIP
ORANGE TRIGGER	BLACK TRIGGER

PROCEDURE		
	① Pulling the Trigger and keeping it pulled. ② Depressing the Contact Arm.	① Depressing the Contact Arm. ② Pulling the Trigger and keeping it pulled.
<b>CONTACT TRIP</b>	The tool fires a nail each time when the Contact Arm is depressed.	<ul style="list-style-type: none"> <li>• The tool fires a nail.</li> </ul>
<b>SEQUENTIAL TRIP</b>	The tool cannot fire a nail.	<ul style="list-style-type: none"> <li>• The tool fires a nail.</li> <li>• The tool cannot fire a second nail until the Trigger is released and the Contact Arm is left work surface.</li> </ul>

## DRIVING DEPTH ADJUSTMENT

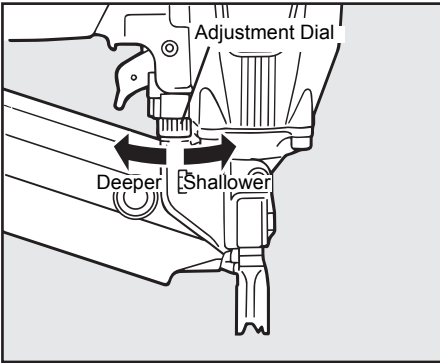

### WARNING

**ALWAYS** disconnect air supply before making adjustment.

The driving depth adjustment is made by adjusting the Adjustment Dial.

- ① With air pressure set, drive a few nails into a representative material sample to determine if adjustment is necessary.
- ② If adjustment is required, disconnect air supply.
- ③ Refer to the mark on the Contact Arm area for direction to turn the Adjustment Dial.
- ④ Re-connect air supply.

## TRIGGER LOCK MECHANISM

The tool is equipped with a Trigger Lock Mechanism. Push and rotate the Trigger from LOCK to the Trigger UNLOCK position before driving nails.

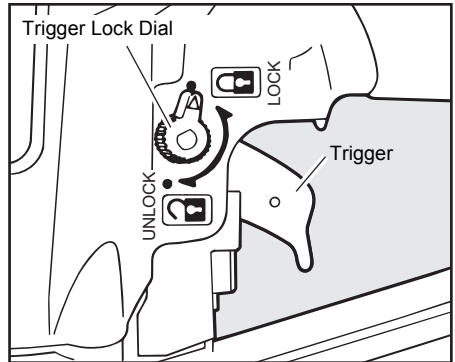

## REMOVING JAMMED NAILS

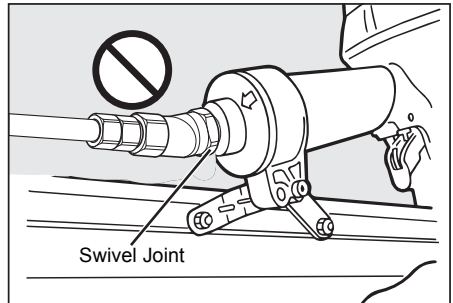

### WARNING

**ALWAYS** disconnect air supply before removing jammed nails.



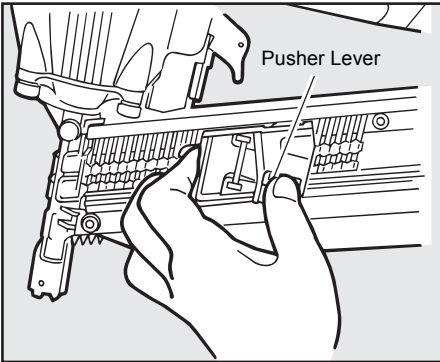

**PROCEDURE**

- ① Push down the Pusher Lever and release the strip nails from the Pusher.

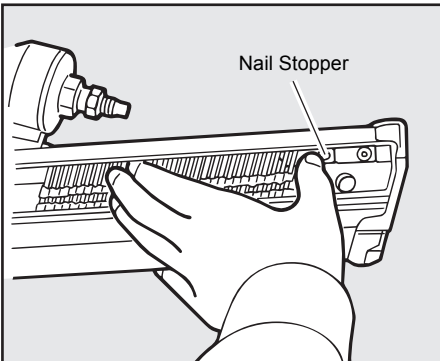

- ② Push the Nail Stopper, and remove the strip nails from inside of the Magazine.

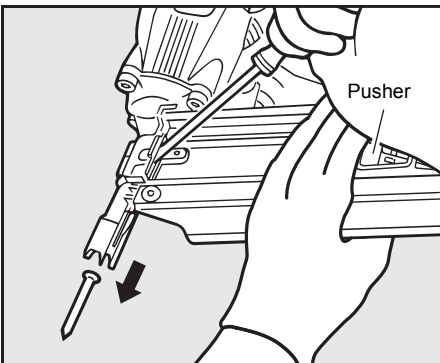

- ③ Pull and stayed the Pusher with hand.
- ④ Remove the jammed nail from the Nose using the punch or a slotted screw driver.



**WARNING**

When removing the jammed nail, wear the gloves. Do not remove the jammed nail with your bare hands.

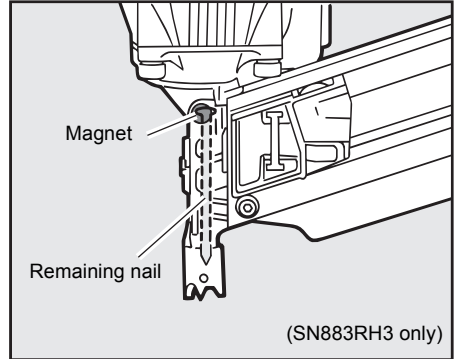

**WARNING**

**Nails are held in the Nose of the tool by magnet. (SN883RH3 only)**

This tool equips a magnet in the Nose to drive out all nails loaded in the Magazine. Therefore, in the case the collation strip is broken, there are nails remaining in the Nose even if you think that you removed whole nails. In this case, there is possibility of serious accident if you think that there are no nails and activate the tool. For that reason, when you remove the nails from the Magazine, confirm that there are no nails in the Nose besides disconnect air supply.

## 5. MAINTENANCE FOR PERFORMANCE

### ① ABOUT PRODUCTION YEAR

This product bears production number at the lower part of the grip of the main body. The two digits of the number from left indicates the production year.

(Example)

1 6 8 2 6 0 3 5 D

└  
Year 2016

### ② DO NOT FIRE THE NAILER WHEN IT IS EMPTY

### ③ USE A 3-PIECE AIRSET

Failure to use a 3-piece airset allows the moisture and dirt inside compressor to pass into the tool directly. This causes rust and wear, and results in a poor operating performance. The hose length between airset and tool should be no longer than 5 m since a longer length results in a reduction in air pressure.

### ④ USE RECOMMENDED OIL

The velocite or turbine oil should be used to lubricate the tool. Upon completion of operations, place 2 or 3 drops of oil into the air plug inlet with the jet oiler. (Recommended Oil : ISO VG32)

### ⑤ INSPECT AND MAINTAIN DAILY OR BEFORE OPERATION



#### WARNING

**Disconnect air supply and empty the magazine when inspecting or maintaining the tool.**

- (1) Drain air line filter and compressor
- (2) Keep lubricator filled in air 3-pieces set
- (3) Clean filter element of air 3-pieces set
- (4) Tighten all screws
- (5) Keep contact arm moving smoothly

## 6. STORAGE

- ① When not in use for an extended period, apply a thin coat of the lubricant to the steel parts to avoid rust.
- ② Do not store the tool in a cold weather environment. Keep the tool in a warm area.
- ③ When not in use, the tool should be stored in a warm and dry place. Keep out of reach of children.
- ④ All quality tools will eventually require servicing or replacement of parts because of wear from the normal use.

## 7. TROUBLE SHOOTING/REPAIRS

The troubleshooting and/or repairs shall be carried out only by the MAX CO., LTD. authorised distributors or by other specialists.

- The content of this manual might be changed without notice for improvement.
  - Le contenu de ce manuel est sujet a modification sans preavis a des fins d'amelioration.
  - El contenido de este manual puede ser cambiado sin noticia previa para mejoramiento.
- 
- The specifications and design of the products in this manual will be subject to change without advance notice due to our continuous efforts to improve the quality of our products.
  - Les caractéristiques et la conception des produits mentionnés dans ce manuel sont sujettes à des modifications sans préavis en raison de nos efforts continus pour améliorer la qualité de nos produits.
  - Las características y la concepción de los productos mencionados en este manual están sujetas a modificaciones sin preaviso debido a nuestros esfuerzos continuos para mejorar la calidad de nuestros productos.



**MAX USA CORP.**  
257 East 2nd Street  
Mineola, NY 11501, U.S.A.  
TEL: 1-800-223-4293  
FAX: (516)741-3272

**[www.maxusacorp.com](http://www.maxusacorp.com) (USA Site)**  
**[wis.max-ltd.co.jp/int/](http://wis.max-ltd.co.jp/int/) (GLOBAL Site)**



4100424  
160509-00/03

